



Chipsmall Limited consists of a professional team with an average of over 10 year of expertise in the distribution of electronic components. Based in Hongkong, we have already established firm and mutual-benefit business relationships with customers from,Europe,America and south Asia,supplying obsolete and hard-to-find components to meet their specific needs.

With the principle of “Quality Parts,Customers Priority,Honest Operation,and Considerate Service”,our business mainly focus on the distribution of electronic components. Line cards we deal with include Microchip,ALPS,ROHM,Xilinx,Pulse,ON,Everlight and Freescale. Main products comprise IC,Modules,Potentiometer,IC Socket,Relay,Connector.Our parts cover such applications as commercial,industrial, and automotives areas.

We are looking forward to setting up business relationship with you and hope to provide you with the best service and solution. Let us make a better world for our industry!



## Contact us

Tel: +86-755-8981 8866 Fax: +86-755-8427 6832

Email & Skype: info@chipsmall.com Web: www.chipsmall.com

Address: A1208, Overseas Decoration Building, #122 Zhenhua RD., Futian, Shenzhen, China





# AP1014AEC

## 7.0V Dual H-Bridge Motor Driver IC

### 1. General Description

The AP1014AEC has four drive mode of forward, reverse, brake and standby by 2 channel H-bridge Motor Driver corresponding to operating voltage 7.0V. It is possible to set to the input logic which was suitable for the PWM drive with the SEL terminal. The AP1014AEC layout N-ch LDMOS FET in high side and low side in output circuit and realize a small WL-CSP package. Also it has under voltage detection and thermal shut down circuits. It is suitable for driving various small motor.

### 2. Features

- Control Supply Voltage 2.7V to 5.5V
- Wide Motor Drive Operating Voltage 2.0V to 7.0V
- Maximum Output Current (DC) 1.1A @Ta=25°C, 0.8A @Ta=85°C
- Maximum Output Current (Peak) 2.0A (Ta=25°C, 10ms/200ms)
- H-Bridge ON Resistance RON (TOP+BOT)=0.35Ω @Ta=25°C
- Built-in Under Voltage Detection Circuit Detect VC Supply Voltage under 2.2V
- Built-in Thermal Shut Down Circuit (Tj) 175°C
- Junction Temperature 150°C
- Package 16-pin WL-CSP (1.96mm×1.96mm )

**3. Table of Contents**

1. General Description .....	1
2. Features .....	1
3. Table of Contents.....	2
4. Block Diagram .....	3
5. Ordering Guide .....	3
6. Pin Configurations and Functions.....	4
■ Pin Configurations.....	4
■ Function.....	4
■ Terminal Equivalent Circuit .....	5
7. Absolute Maximum Ratings .....	6
8. Recommended Operating Conditions .....	7
9. Electrical Characteristics.....	7
10. Description .....	9
11. Recommended External Circuits.....	10
12. Package .....	11
■ Outline Dimensions .....	11
■ Marking .....	11
13. Revise History .....	12
IMPORTANT NOTICE.....	13

**4. Block Diagram**

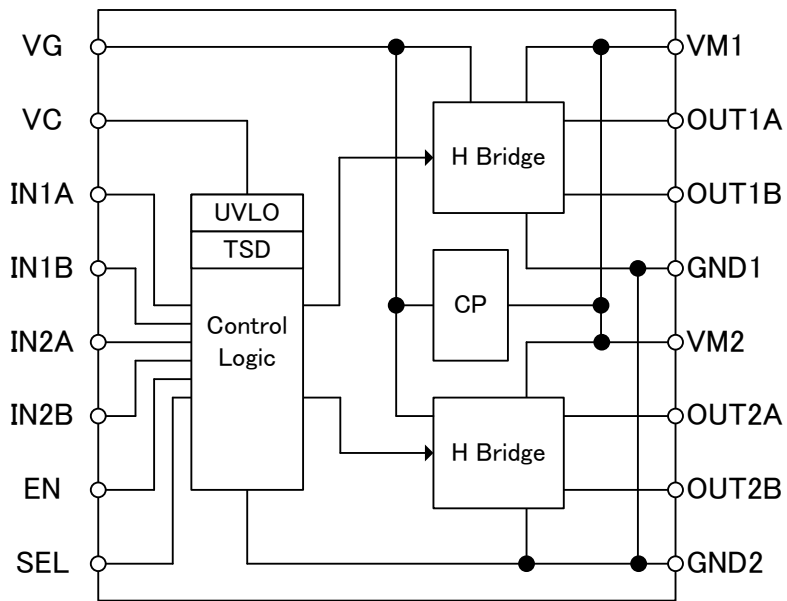

Figure 1. Block Diagram

**5. Ordering Guide**

AP1014AEC	-30~85°C	16-pin WL-CSP (1.96mm×1.96mm)
-----------	----------	-------------------------------

## 6. Pin Configurations and Functions

### ■ Pin Configurations

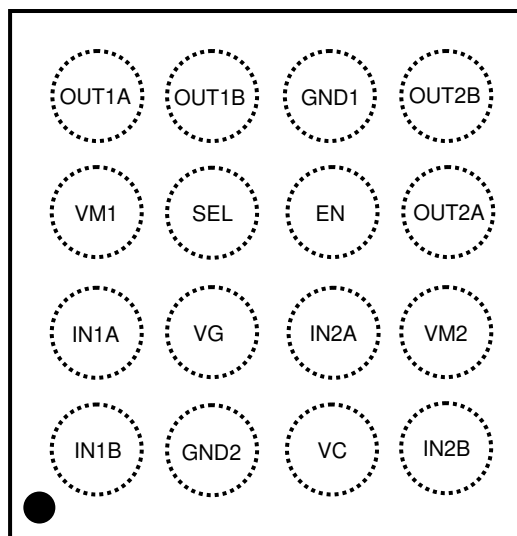

(Top View)

### ■ Function

Pin Number	Name	I/O (Note 1)	Functions	Remark
A1	IN1B	I	Control signal input terminal	
A2	IN1A	I	Control signal input terminal	
A3	VM1	P	Motor driver power supply	
A4	OUT1A	O	Motor driver output Terminal	
B1	GND2	P	Power ground terminal	
B2	VG	P	Charge pump output capacitor connection terminal	
B3	SEL	I	Input logic selection pin	200kΩ Pull-down
B4	OUT1B	O	Motor driver output Terminal	
C1	VC	P	Control power supply	
C2	IN2A	I	Control signal input terminal	
C3	EN	I	Enable signal input terminal	200kΩ Pull-down
C4	GND1	P	Power ground terminal	
D1	IN2B	I	Control signal input terminal	
D2	VM2	P	Motor driver power supply	
D3	OUT2A	O	Motor driver output Terminal	
D4	OUT2B	O	Motor driver output Terminal	

Note 1. I (Input terminal), O (Output terminal) and P (Power terminal)

■ Terminal Equivalent Circuit

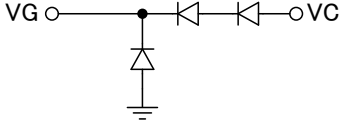
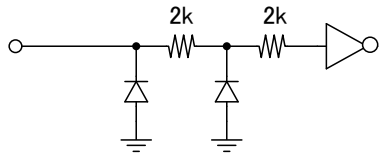
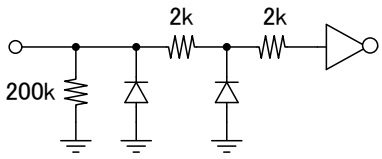
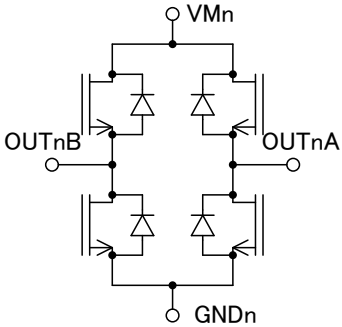
Pin name	Name	Functions	Equivalent Circuits
C1	VC	Control power supply	
A3 D2	VM1 VM2	Motor driver power supply VM1 and VM2 are short-circuited inside IC.	
B2	VG	Charge pump output	
A2 A1 C2 D1	IN1A IN1B IN2A IN2B	Control signal input	
C3 B3	EN SEL	Logic input (Built-in 200kΩ pull-down resistor)	
A4 B4 D3 D4	OUT1A OUT1B OUT2A OUT2B	Motor driver output	
C4 B1	GND1 GND2	Ground terminal GND1 and GND2 are short-circuited inside IC.	



**7. Absolute Maximum Ratings**

Parameter	Symbol	min	max	Unit	Condition
Control supply voltage	VC	-0.5	6	V	
Motor supply voltage	VM	-0.5	7.5	V	VC = 2.7~5.5V
VC level terminal voltage (INnA, IN1nB, SEL and EN )	Vterminal1	-0.5	VC	V	
VM level terminal voltage (OUTnA and OUTnB)	Vterminal2	-0.5	VM	V	
VC+VM level terminal voltage (VG)	Vterminal3	-0.5	13.5	V	
Maximum output current @ 2ch drive	IloadcMD	-	1.1	A/ch	Ta=25°C
		-	0.8	A/ch	Ta=85°C
Maximum output current @ 1ch drive	IloadcMD	-	1.5	A	Ta=25°C
		-	1.1	A	Ta=85°C
Maximum output peak current	IloadpeakMD	-	2.0	A	Under 10ms in 200ms
Power dissipation	PD	-	1760	mW	Ta=25°C (Note 3)
		-	915	mW	Ta=85°C (Note 3)
Operating Temperature range	Ta	-30	85	°C	
Junction temperature	Tj		150	°C	
Storage temperature	Tstg	-65	150	°C	

Note 2. All above voltage is defined to GNDn=0V.

Note 3. When the 2-layer board is used. This is calculated RθJ = (71)°C /W.

**WARNING:** Operation at or beyond these limits may result in permanent damage to the device. Normal operation is guaranteed at these extremes.

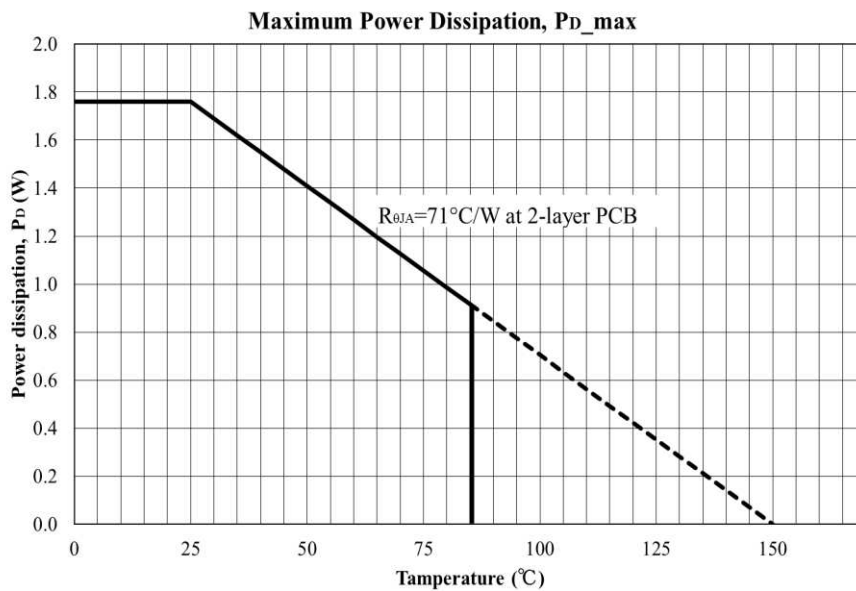

Figure 2. Maximum Power Dissipation

## 8. Recommended Operating Conditions

(Ta = 25°C, unless otherwise specified)

Parameter	Symbol	min	typ	max	Unit	Condition
Control supply voltage	VC	2.7	3.0	5.5	V	
Motor driver supply voltage	VM	2.0	5.0	7.0	V	
Input pulse frequency	Fin	-	-	200	kHz	50%duty

## 9. Electrical Characteristics

(Ta = 25°C, VM=5.0V, VC = 3.0V, unless otherwise specified)

Parameter	Symbol	Condition	min	typ	max	Unit
<b>Charge pump</b>						
Charge pump voltage	VG	VG=VC+VM	7.0	7.5	8.0	V
Charge pump wake up time	tVG <sub>ON</sub>	VG=VC+VM-1.0V	-	0.3	3.0	ms
<b>VDET</b>						
VC under voltage detect voltage	VC <sub>DETLV</sub>		1.9	2.2	2.5	V
<b>TSD</b>						
Thermal shut down temperature (Note 4)	T <sub>DET</sub>		150	175	200	°C
Temperature hysteresis (Note 4)	T <sub>DETHYS</sub>		20	30	40	°C
<b>Quiescent current</b>						
VM quiescent current at power off	I <sub>VMPOFF</sub>	EN="L" All internal circuits are power off.	-	-	1.0	μA
VC quiescent current at power off	I <sub>VCPOFF</sub>		-	-	1.0	μA
VM quiescent current at standby	I <sub>VMSTBY</sub>	EN="H", SEL="L" INnA="L", INnB="L"	-	40	200	μA
VC quiescent current at standby	I <sub>VCSTBY</sub>		-	150	500	μA
VC quiescent current at PWM operation	I <sub>VCPWM</sub>	f <sub>PWM</sub> =200kHz, Duty=50%	-	0.5	1.5	mA
<b>Motor Driver</b>						
Driver on resistance (High side + Low side)	R <sub>ON1</sub>	I <sub>load</sub> =100mA, Ta=25°C	-	0.35	0.46	Ω
Driver on resistance (High side + Low side) (Note 4)	R <sub>ON2</sub> Design certification	I <sub>load</sub> =0.7A, Ta=25°C	-	0.38	0.53	Ω
Driver on resistance (High side + Low side) (Note 4)	R <sub>ON3</sub> Design certification	I <sub>load</sub> =0.7A, Ta=85°C	-	0.48	0.72	Ω
Body diode forward voltage	V <sub>FMD</sub>	I <sub>F</sub> =100mA	-	0.8	1.2	V
<b>Control logic</b>						
Input High level voltage (INnA, INnB, SEL and EN)	V <sub>IH</sub>	VC=2.7V~5.5V	0.7×VC	-	-	V
Input Low level voltage (INnA, INnB, SEL and EN)	V <sub>IL</sub>		-	-	0.3×VC	V
Input High level current (SEL and EN)	I <sub>IH</sub>	V <sub>IH</sub> =3.0V	9	15	21	μA



Parameter	Symbol	Condition	min	typ	max	Unit
Input Low level current (INnA and INnB)	IIL	$V_{IL}=0V$	-1.0	-	-	$\mu A$
Input pulse rize time (INnA and INnB)	tr	$V_C=2.7V\sim 5.5V$	-	-	1.0	$\mu s$
Input pulse fall time (INnA and INnB)	tf		-	-	1.0	$\mu s$
H-Bridge propagation delay time (INnB="L"→OUTnA="H") (Figure 3(a))	tPDLH	1k $\Omega$ Load between OUTnA and OUTnB. SEL="L", NnA = "H", INnB = 200kHz	-	-	0.5	$\mu s$
H-Bridge propagation delay time (INnB="H"→OUTnA="L") (Figure 3(a))	tPDHL		-	-	0.5	$\mu s$
H-Bridge propagation delay time (Hi-Z→"H") (Note 4) (Figure 3(c))	tPDZH	10 $\Omega$ Load between OUTnA/B and GND. 10 $\Omega$ Load between OUTnA/B and VM. The time from 50% input to 90% output	-	-	0.5	$\mu s$
H-Bridge propagation delay time (Hi-Z→"L") (Note 4) (Figure 3(d))	tPDZL	10 $\Omega$ Load between OUTnA/B and GND. 10 $\Omega$ Load between OUTnA/B and VM. The time from 50% input to 10% output	-	-	0.5	$\mu s$
H-bridge output pulse width (Note 4) (Figure 3 (b))	tPW	20 $\Omega$ Load between OUTA and OUTB. input pluse width : 1 $\mu s$	0.7	-	1.5	$\mu s$

Note 4. Not tested in production.

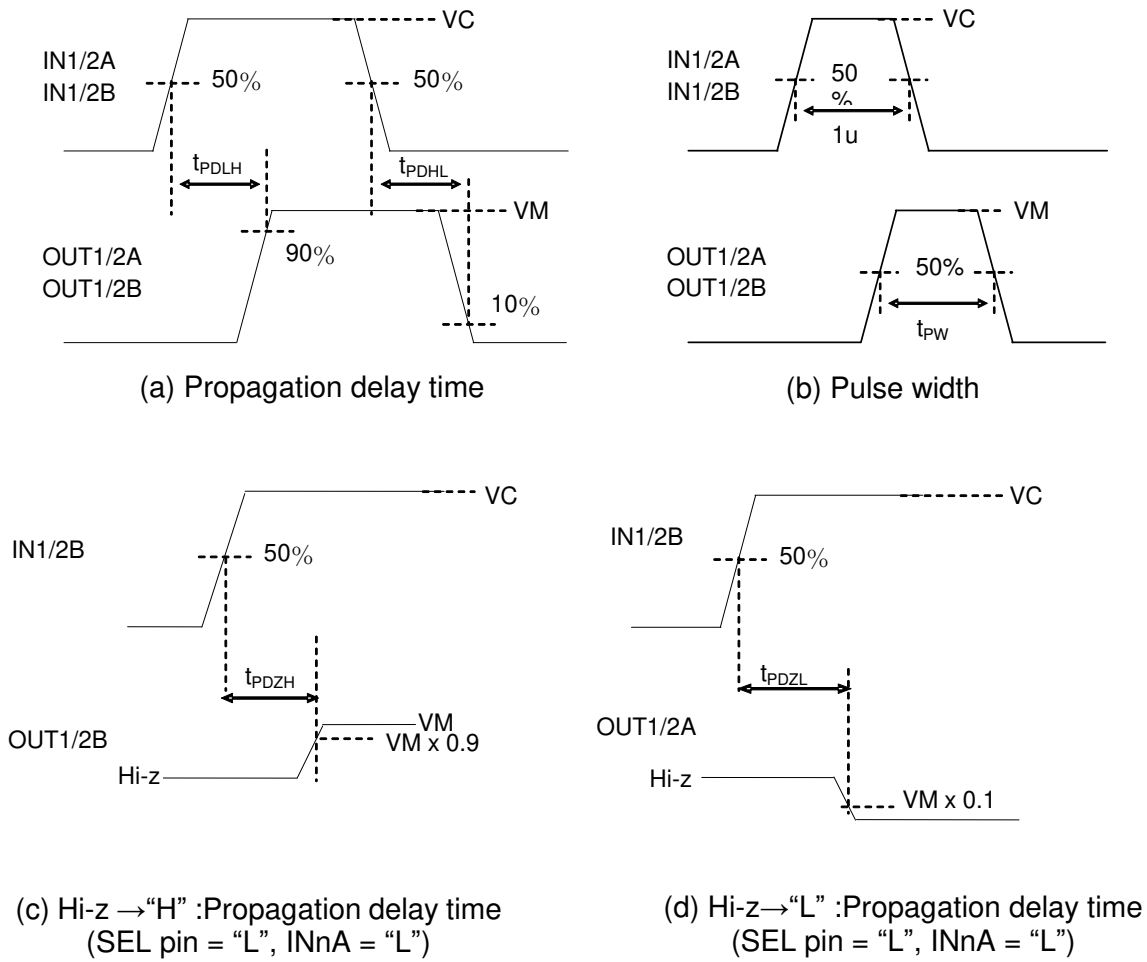

Figure 3. Time chart of propagation delay time and pulse width

**10. Description**

The relations of the input and output with each mode are as follows.

Table 1.

		Input		Output		Motion	
EN	SEL	INnA	INnB	OUTnA	OUTnB		
H	L	L	L	Z	Z	Standby (Idling)	
		L	H	L	H	Reverse	
		H	L	H	L	Forward	
		H	H	L	L	Brake (Stop)	
	H	L	X	X	L	L	Brake (Stop)
		H	L	L	H	L	Forward
		H	H	H	L	H	Reverse
L	X	X	X	Z	Z	Power off (Idling)	

**11. Recommended External Circuits**

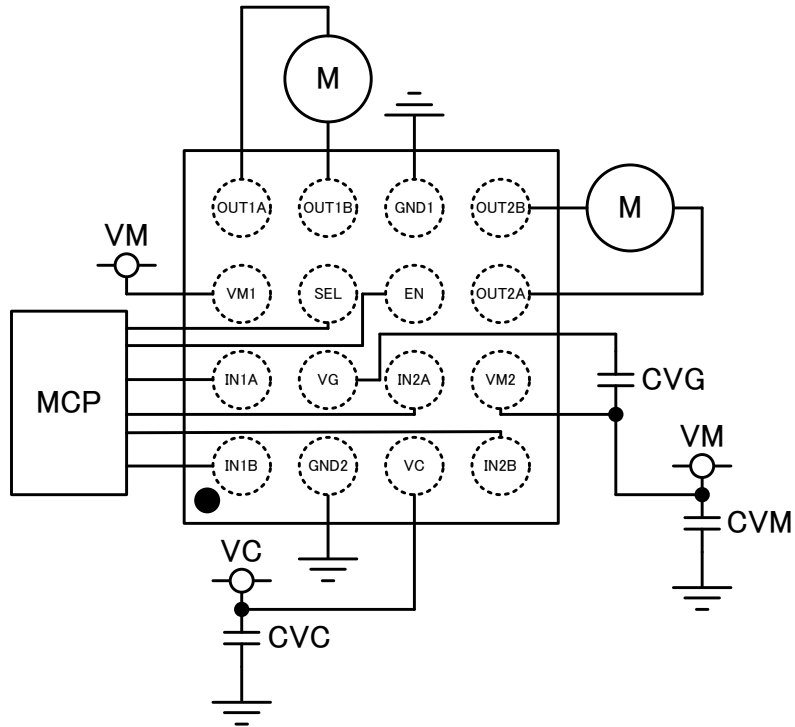

Figure 4. Recommended External Circuits (Top view)

Table 2. Recommended external components example

Items	Symbol	min	typ	max	unit	Comments
Motor driver power supply connection decoupling capacitor	CVM	1.0	10	-	μF	(Note 6)
Control power supply connection bypass capacitor	CVC	0.1	1.0	-	μF	(Note 6)
Charge pump capacitance	CVG	0.047	0.1	0.22	μF	

Note 5. Above capacitance is an example. Please choose your best capacitance by checking load current profile, load capacitance and layout resistance and so on, on your own board before you apply.

Note 6. Please adjust the connecting capacitor of CVM and CVC depending on the load current profile, the load capacitance, the line resistance and etc. with each application boards.

**12. Package**

■ **Outline Dimensions**

(Unit: mm)

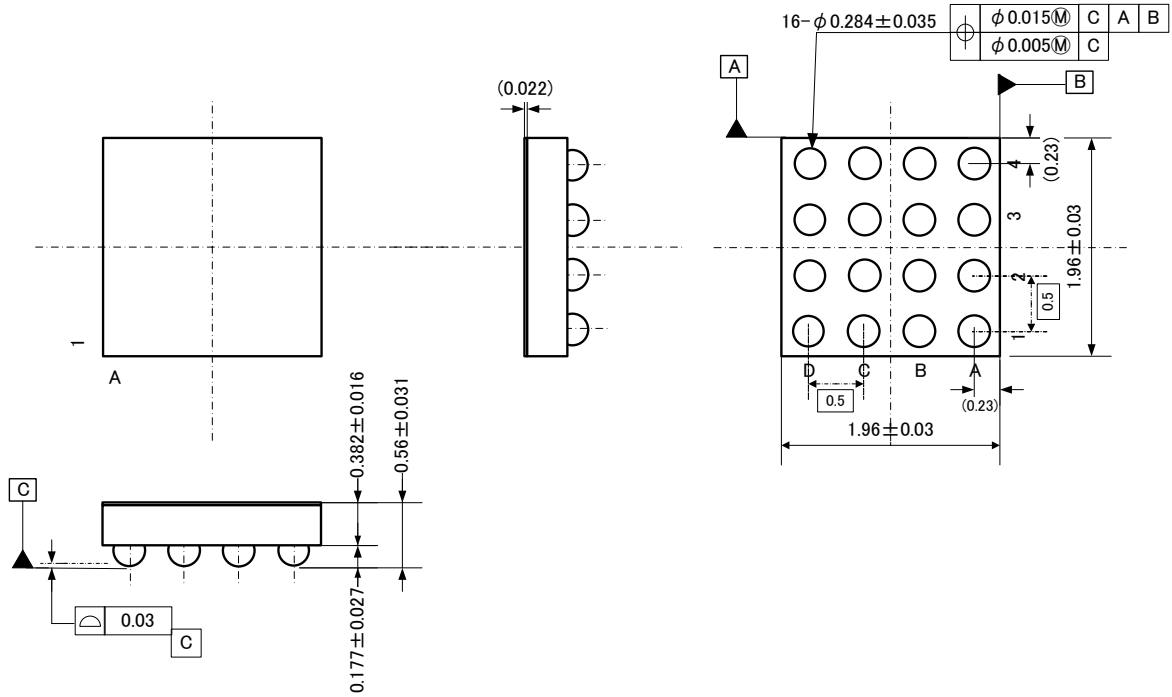

■ **Marking**

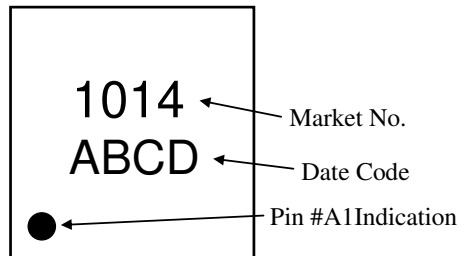

YWWA: Date code (4 digit)

A: Manage number

WW: Producing week

Y: Producing year (Ex: 2014 → “4”)

**13. Revise History**

Date (YY/MM/DD)	Revision	Page	Contents
14/03/06	00		First edition
14/08/07	01	8	Propagation delay time (Hi-Z →“H”, “H”→Hi-Z)Condition “Time to change from 50% to 75%” → “The time from 50% input to 90% output” “Time to change from 50% to 25%” → “The time from 50% input to 10% output”
		9	Figure3 (Time chart)was added.

**IMPORTANT NOTICE**

0. Asahi Kasei Microdevices Corporation (“AKM”) reserves the right to make changes to the information contained in this document without notice. When you consider any use or application of AKM product stipulated in this document (“Product”), please make inquiries the sales office of AKM or authorized distributors as to current status of the Products.
1. All information included in this document are provided only to illustrate the operation and application examples of AKM Products. AKM neither makes warranties or representations with respect to the accuracy or completeness of the information contained in this document nor grants any license to any intellectual property rights or any other rights of AKM or any third party with respect to the information in this document. You are fully responsible for use of such information contained in this document in your product design or applications. **AKM ASSUMES NO LIABILITY FOR ANY LOSSES INCURRED BY YOU OR THIRD PARTIES ARISING FROM THE USE OF SUCH INFORMATION IN YOUR PRODUCT DESIGN OR APPLICATIONS.**
2. The Product is neither intended nor warranted for use in equipment or systems that require extraordinarily high levels of quality and/or reliability and/or a malfunction or failure of which may cause loss of human life, bodily injury, serious property damage or serious public impact, including but not limited to, equipment used in nuclear facilities, equipment used in the aerospace industry, medical equipment, equipment used for automobiles, trains, ships and other transportation, traffic signaling equipment, equipment used to control combustions or explosions, safety devices, elevators and escalators, devices related to electric power, and equipment used in finance-related fields. Do not use Product for the above use unless specifically agreed by AKM in writing.
3. Though AKM works continually to improve the Product’s quality and reliability, you are responsible for complying with safety standards and for providing adequate designs and safeguards for your hardware, software and systems which minimize risk and avoid situations in which a malfunction or failure of the Product could cause loss of human life, bodily injury or damage to property, including data loss or corruption.
4. Do not use or otherwise make available the Product or related technology or any information contained in this document for any military purposes, including without limitation, for the design, development, use, stockpiling or manufacturing of nuclear, chemical, or biological weapons or missile technology products (mass destruction weapons). When exporting the Products or related technology or any information contained in this document, you should comply with the applicable export control laws and regulations and follow the procedures required by such laws and regulations. The Products and related technology may not be used for or incorporated into any products or systems whose manufacture, use, or sale is prohibited under any applicable domestic or foreign laws or regulations.
5. Please contact AKM sales representative for details as to environmental matters such as the RoHS compatibility of the Product. Please use the Product in compliance with all applicable laws and regulations that regulate the inclusion or use of controlled substances, including without limitation, the EU RoHS Directive. AKM assumes no liability for damages or losses occurring as a result of noncompliance with applicable laws and regulations.
6. Resale of the Product with provisions different from the statement and/or technical features set forth in this document shall immediately void any warranty granted by AKM for the Product and shall not create or extend in any manner whatsoever, any liability of AKM.
7. This document may not be reproduced or duplicated, in any form, in whole or in part, without prior written consent of AKM.