



Chipsmall Limited consists of a professional team with an average of over 10 year of expertise in the distribution of electronic components. Based in Hongkong, we have already established firm and mutual-benefit business relationships with customers from,Europe,America and south Asia,supplying obsolete and hard-to-find components to meet their specific needs.

With the principle of “Quality Parts,Customers Priority,Honest Operation,and Considerate Service”,our business mainly focus on the distribution of electronic components. Line cards we deal with include Microchip,ALPS,ROHM,Xilinx,Pulse,ON,Everlight and Freescale. Main products comprise IC,Modules,Potentiometer,IC Socket,Relay,Connector.Our parts cover such applications as commercial,industrial, and automotives areas.

We are looking forward to setting up business relationship with you and hope to provide you with the best service and solution. Let us make a better world for our industry!



Contact us

Tel: +86-755-8981 8866 Fax: +86-755-8427 6832

Email & Skype: info@chipsmall.com Web: www.chipsmall.com

Address: A1208, Overseas Decoration Building, #122 Zhenhua RD., Futian, Shenzhen, China



Features

- Input Voltage Range is from 2.7 to 5.5V
- Dropout Voltage 400mV at 300mA Output Current
- Guaranteed 300mA Output Current
- Internal Ron = 1.5Ω PMOS draws no Base Current
- Low Quiescent Current 50μA
- Output Voltage: 1.5V/1.8V/2.0V/2.5V/2.8V/2.9V/3.0V/3.3V/ 3.5V; Accuracy 2%
- Active Low Shutdown Function (EN pin)
- Fast Transient Response
- Good Load Regulation
- Current Limit and Thermal Shutdown Protection
- Short Circuit Current Fold-Back
- Lead Free package: SOT25
- SOT25: Available in "Green" Molding Compound (No Br, Sb)
- Lead Free Finish/RoHS Compliant (Note 1)

General Description

The AP131 is a 300mA, fixed output voltage, low dropout linear regulator. The Device included pass element, error amplifier, band-gap, current limit and thermal shutdown circuitry. The device is ON when the EN pin is set to logic high level.

The characteristics of low dropout voltage and less quiescent current make it good for some critical current applications, for example, some battery powered devices. The typical quiescent current is approximately 50μA from zero to maximum load. Due to the internal flexible design, it results in extensively fixed output voltage versions and makes it convenient to use for applications. Built-in current-limit and thermal-shutdown functions prevent any fault condition from IC damage. An external capacitor can be connected to the BP pin and reduce the output noise.

Applications

- Battery Powered Device
- Wireless Communication
- CD-ROM, DVD, and LAN Card
- PC Peripheral

Ordering Information

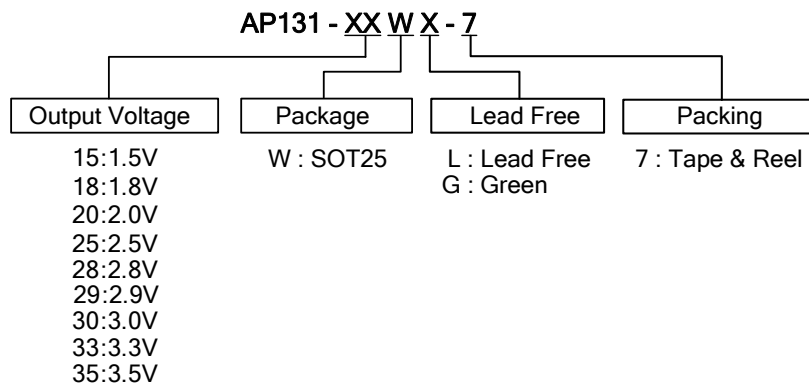

Device	Package Code	Packaging (Note 2)	7" Tape and Reel	
			Quantity	Part Number Suffix
AP131-XXWL-7	W	SOT25	3000/Tape & Reel	-7
AP131-XXWG-7	W	SOT25	3000/Tape & Reel	-7

Notes: 1. EU Directive 2002/95/EC (RoHS). All applicable RoHS exemptions applied. Please visit our website at http://www.diodes.com/products/lead_free.html.
2. Pad layout as shown on Diodes Inc. suggested pad layout document AP02001, which can be found on our website at <http://www.diodes.com/datasheets/ap02001.pdf>.

Pin Assignment

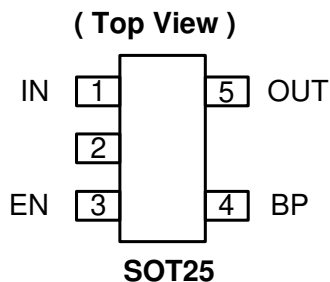

Pin Description

Pin Name	Description
IN	Input Voltage
GND	Ground
EN	Enable Pin
BP	Band-gap
OUT	Output Voltage

Block Diagram

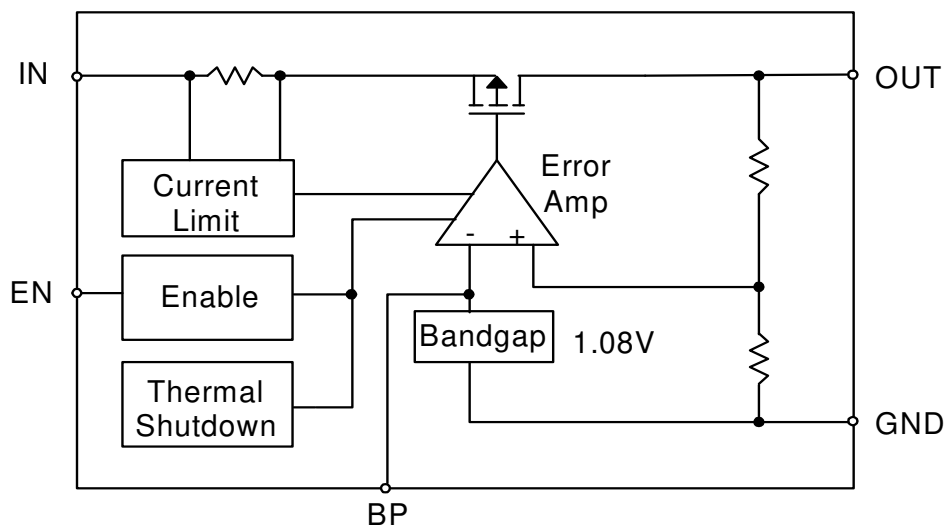

Absolute Maximum Ratings

Symbol	Parameter	Rating	Unit
V_{CC}	Input Voltage	+6	V
T_{OP}	Operating Junction Temperature Range	-40 to +125	°C
T_{ST}	Storage Temperature Range	-65 to +150	°C
P_D	Power Dissipation, $P_D @ T_A = 25^\circ\text{C}$	SOT25 250	mW

Recommended Operating Conditions

Symbol	Parameter	Min	Max	Unit
V_{IN}	Input Voltage	2.7	5.5	V
I_{OUT}	Output Current	0	300	mA
T_A	Operating Ambient Temperature	-40	85	°C

Electrical Characteristics

$T_A = 25^\circ\text{C}$, $C_{IN} = 1\mu\text{F}$, $C_{OUT} = 10\mu\text{F}$, unless otherwise specified.

Symbol	Parameter	Conditions	Min	Typ.	Max	Unit
$V_{DROPOUT}$	Dropout Voltage (Note 3)	$I_L = 300\text{mA}$	-	400	500	mV
I_{LIMIT}	Current Limit (Note 4)	$V_{IN} = 5\text{V}$, $V_{OUT} = 0\text{V}$	350	450	-	mA
I_{SHORT}	Short Circuit Current	$V_{OUT} < 1.05\text{V}$	-	150	300	mA
ΔV_{LINE}	Line Regulation	$I_{OUT} = 1\text{mA}$, $V_{IN} = (V_{OUT} + 1\text{V})$ to 5.5V	-	0.1	0.3	%/V
ΔV_{LOAD}	Load Regulation (Note 5)	$I_L = 1 \sim 300\text{mA}$, $V_{IN} = 5\text{V}$	-	30	35	mV
ΔV_{OUT}	Output Voltage Accuracy	$I_L = 1\text{mA}$, $V_{IN} = 5\text{V}$	-2	-	+2	%
	Output Voltage Temperature Coefficient (Note 6)		-	50	150	PPM/ $^\circ\text{C}$
PSRR	Ripple Rejection	$F = 100\text{Hz}$, $C_{IN} = 1\mu\text{F}$, $C_{O} = 10\mu\text{F}$, $I_L = 100\text{mA}$	-	60	-	dB
I_{SB}	Standby Current	$I_L = 0\text{mA}$, $V_{IN} = 5\text{V}$, $EN = 0\text{V}$	-	-	5	μA
I_Q	Quiescent Current	$I_L = 0\text{mA}$, $V_{IN} = 5\text{V}$, $EN = 5\text{V}$	-	50	100	μA
I_{EN}	Enable Pin Current		-	-	< 0.1	μA
V_{ENON}	Enable Pin Voltage	Output ON	1.5	-	V_{IN}	V
V_{ENOFF}		Output OFF	0	-	0.8	V
T_{DELAY}	Enable Delay Time	$C_{BP} = 0.1\mu\text{F}$, $C_{OUT} = 1\mu\text{F}$, $I_{OUT} = 30\text{mA}$	-	8	-	μS
θ_{JA}	Thermal Resistance Junction-to-Ambient	SOT25 (Note 7)		163		$^\circ\text{C/W}$
θ_{JC}	Thermal Resistance Junction-to-Case	SOT25 (Note 7)		53		$^\circ\text{C/W}$

- Notes:
- Dropout voltage is defined as the input to output differential voltage. Dropout is measured at constant junction temperature by using pulsed ON time, and the criterion is V_{OUT} inside target value $\pm 2\%$. This test is skipped at the condition of $V_{IN} < 3\text{V}$.
 - Current limit is measured at constant junction temperature by using pulsed testing with a low ON time.
 - Regulation is measured at constant junction temperature by using pulsed testing with a low ON time.
 - Guaranteed by design.
 - Test conditions for SOT25: Device mounted on FR-4 substrate PC board, 2oz copper, with minimum recommended pad layout.

Typical Characteristics

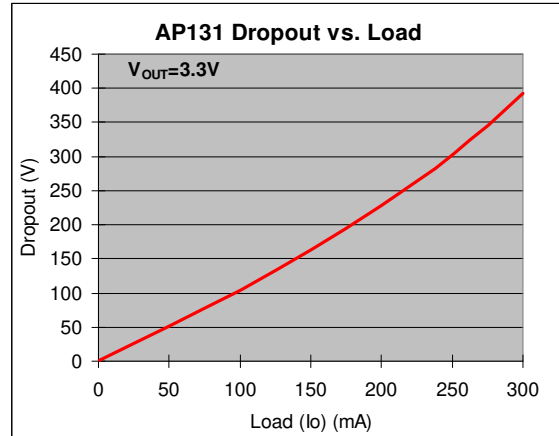
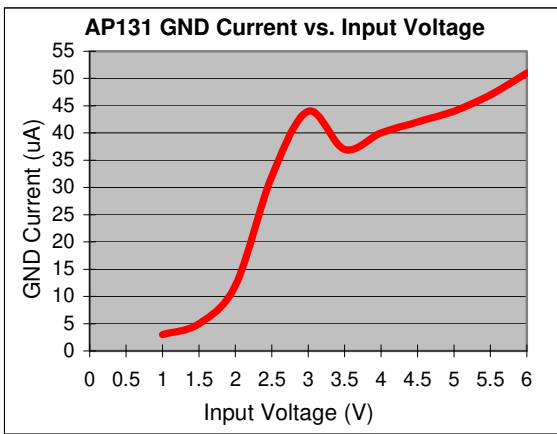
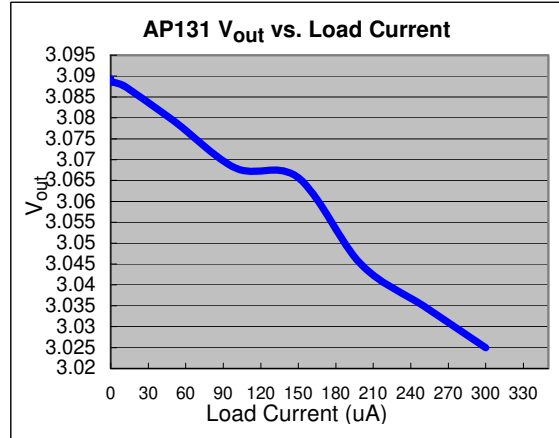
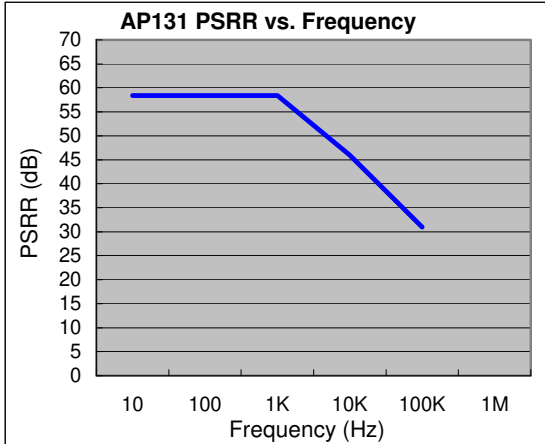

Typical Application Circuit

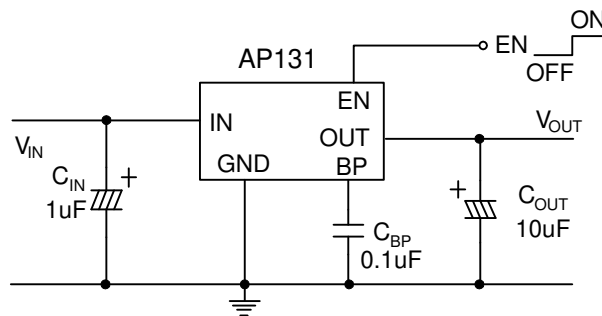

Marking Information

(1) SOT25

(Top View)

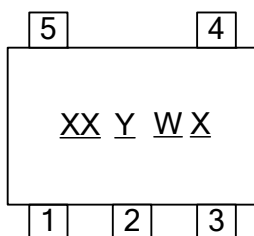

XX : Identification code
Y : Year 0~9
W : Week : A~Z : 1~26 week;
 a~z : 27~52 week; z represents
 52 and 53 week
X : a~z : Lead Free
 A~Z : Green

Part Number	Package	Identification Code
AP131-15W	SOT25	DA
AP131-18W	SOT25	DD
AP131-20W	SOT25	DF
AP131-25W	SOT25	DK
AP131-28W	SOT25	DN
AP131-29W	SOT25	DO
AP131-30W	SOT25	DP
AP131-33W	SOT25	DS
AP131-35W	SOT25	DU

Package Information (All Dimensions in mm)

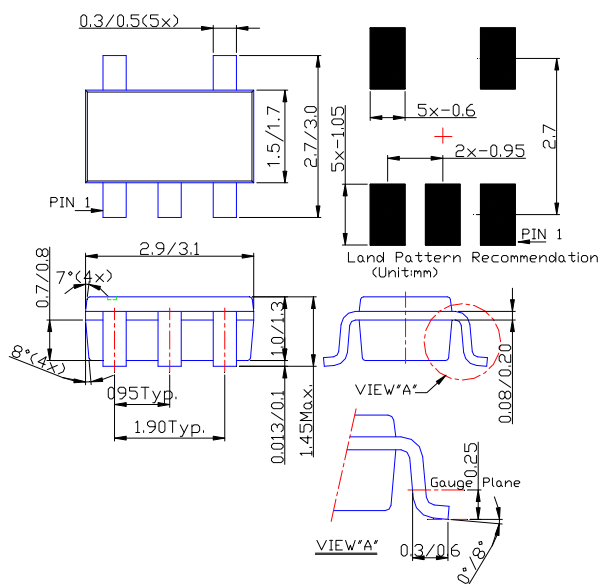

IMPORTANT NOTICE

Diodes Incorporated and its subsidiaries reserve the right to make modifications, enhancements, improvements, corrections or other changes without further notice to any product herein. Diodes Incorporated does not assume any liability arising out of the application or use of any product described herein; neither does it convey any license under its patent rights, nor the rights of others. The user of products in such applications shall assume all risks of such use and will agree to hold Diodes Incorporated and all the companies whose products are represented on our website, harmless against all damages.

LIFE SUPPORT

Diodes Incorporated products are not authorized for use as critical components in life support devices or systems without the expressed written approval of the President of Diodes Incorporated.