



Chipsmall Limited consists of a professional team with an average of over 10 year of expertise in the distribution of electronic components. Based in Hongkong, we have already established firm and mutual-benefit business relationships with customers from,Europe,America and south Asia,supplying obsolete and hard-to-find components to meet their specific needs.

With the principle of “Quality Parts,Customers Priority,Honest Operation,and Considerate Service”,our business mainly focus on the distribution of electronic components. Line cards we deal with include Microchip,ALPS,ROHM,Xilinx,Pulse,ON,Everlight and Freescale. Main products comprise IC,Modules,Potentiometer,IC Socket,Relay,Connector.Our parts cover such applications as commercial,industrial, and automotives areas.

We are looking forward to setting up business relationship with you and hope to provide you with the best service and solution. Let us make a better world for our industry!



Contact us

Tel: +86-755-8981 8866 Fax: +86-755-8427 6832

Email & Skype: info@chipsmall.com Web: www.chipsmall.com

Address: A1208, Overseas Decoration Building, #122 Zhenhua RD., Futian, Shenzhen, China



Features

- Input voltage: 3.6V to 18V.
- Output voltage: 0.8V to V_{CC} .
- Duty ratio: 0% to 100% PWM control
- Oscillation frequency: 300kHz typ.
- Current Limit, Enable function
- Thermal Shutdown function
- Built-in internal SW P-channel MOS
- Lead Free package: SOP-8L
- SOP-8L: Available in "Green" Molding Compound (No Br, Sb) (Note 1)
- Lead Free Finish/ RoHS Compliant (Note 2)

General Description

AP1530 consists of step-down switching regulator with PWM control. These devices include a reference voltage source, oscillation circuit, error amplifier and internal PMOS.

AP1530 provides low-ripple power, high efficiency, and excellent transient characteristics. The PWM control circuit is able to vary the duty ratio linearly from 0 up to 100%. This converter also contains an error amplifier circuit. An enable function, an over current protection and a short circuit protection are built inside, and when OCP or SCP happens, the operation frequency will be reduced from 300kHz to 50kHz. Also, an internal compensation block is built in to minimum external component count.

With the addition of an internal P-channel Power MOS, a coil, capacitors, and a diode connected externally, these ICs can function as step-down switching regulators. They serve as ideal power supply units for portable devices when coupled with the SOP-8L package, providing such outstanding features as low current consumption. Since this converter can accommodate an input voltage up to 18V, it is also suitable for the operation via an AC adapter.

Applications

- PCD Motherboard
- LCD Monitor
- Graphic Card
- DVD-Video Player
- Telecom Equipment
- ADSL Modem
- Printer and other Peripheral Equipment
- Microprocessor core supply
- Networking power supply

Typical Application Circuit

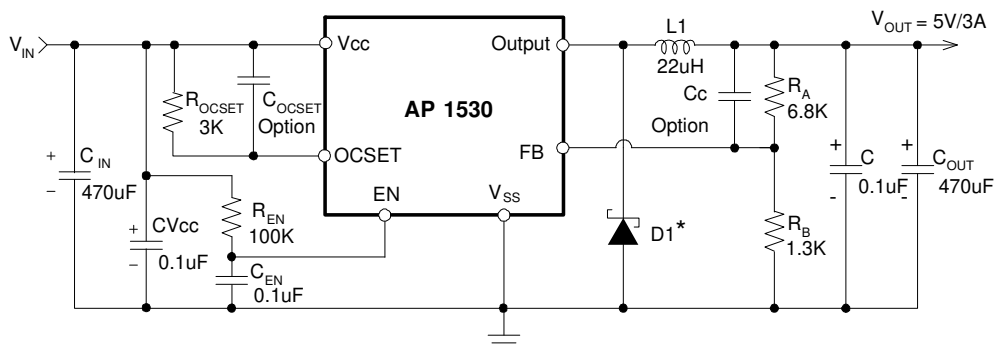

$$V_{OUT} = V_{FB} \times (1 + R_A/R_B)$$

$$R_B = 0.7K \sim 5K \text{ ohm}$$

* Suggested DIODES Power Schottky P/N: B340 series or PDS340.

Ordering Information

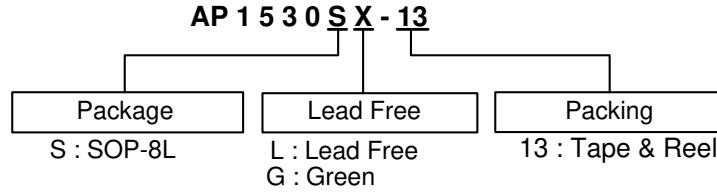

Device	Package Code	Packaging (Note 2)	13" Tape and Reel	
			Quantity	Part Number Suffix
AP1530SL-13	S	SOP-8L	2500/Tape & Reel	-13
AP1530SG-13	S	SOP-8L	2500/Tape & Reel	-13



Notes: 1. EU Directive 2002/95/EC (RoHS). All applicable RoHS exemptions applied. Please visit our website at http://www.diodes.com/products/lead_free.html.
 2. Pad layout as shown on Diodes Inc. suggested pad layout document AP02001, which can be found on our website at <http://www.diodes.com/datasheets/ap02001.pdf>.

Pin Assignments

(1) SOP-8L

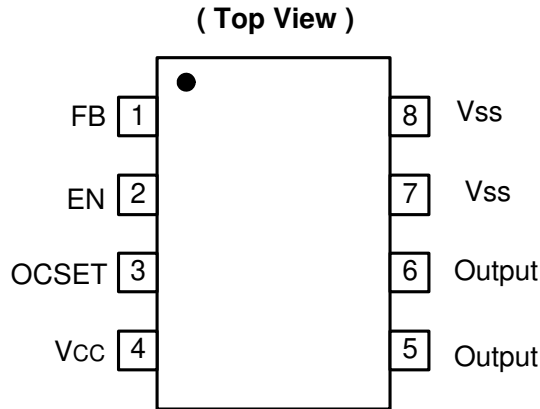

Pin Descriptions

Pin Name	Pin No.	Description
FB	1	Feedback pin
EN	2	Power-off pin H: Normal operation (Step-down operation) L: Step-down operation stopped (All circuits deactivated)
OCSET	3	Add an external resistor to set max output current
V _{CC}	4	IC power supply pin
Output	5, 6	Switch Pin. Connect external inductor/diode here. Minimize trace area at this pin to reduce EMI
V _{SS}	7, 8	GND Pin

Block Diagram

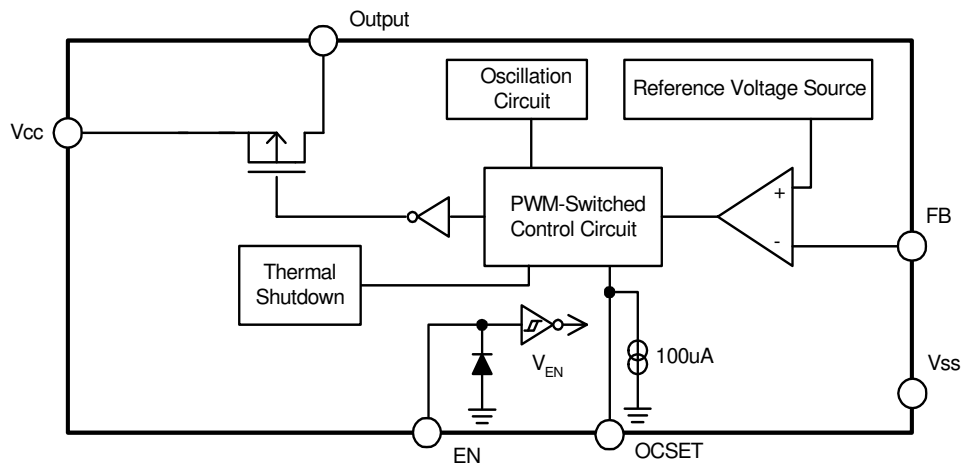

Absolute Maximum Ratings

Symbol	Parameter	Rating	Unit
ESD HBM	Human Body Model ESD Protection	5	KV
ESD MM	Machine Model ESD Protection	500	V
V _{CC}	V _{CC} Pin Voltage	V _{SS} - 0.3 to V _{SS} + 20	V
V _{FB}	Feedback Pin Voltage	V _{SS} - 0.3 to V _{CC}	V
V _{EN}	EN Pin Voltage	V _{SS} - 0.3 to V _{IN} + 0.3	V
V _{OUTPUT}	Switch Pin Voltage	V _{SS} - 0.3 to V _{IN} + 0.3	V
P _D	Power Dissipation	Internally limited	mW
T _J	Operating Junction Temperature Range	-40 to +125	°C
T _{ST}	Storage Temperature Range	-65 to +150	°C

Caution: The absolute maximum ratings are rated values exceeding which the product could suffer physical damage. These values must therefore not be exceeded under any conditions.

Recommended Operating Conditions

Symbol	Parameter	Min	Max	Unit
V _{IN}	Input Voltage	3.6	18	V
I _{OUT}	Output Current	0	3	A
T _A	Operating Ambient Temperature	-20	85	°C

Electrical Characteristics

($V_{IN} = 12V$, $T_A = 25^\circ C$, unless otherwise specified)

Symbol	Parameter	Conditions	Min	Typ.	Max	Unit
V_{FB}	Feedback Voltage	$I_{OUT} = 0.1A$	0.784	0.8	0.816	V
I_{FB}	Feedback Bias Current	$I_{OUT} = 0.1A$	-	0.1	0.5	μA
I_{SW}	Switch Current	--	3.5	-	-	A
I_{SHDN}	Current Consumption During Power Off	$V_{EN} = 0V$	-	10	-	μA
$\frac{\Delta V_{OUT}}{V_{IN}}$	Line Regulation	$V_{IN} = 5V \sim 18V$	-	1	2	%
$\frac{\Delta V_{OUT}}{I_{OUT}}$	Load Regulation	$I_{OUT} = 0.1$ to 3A	-	0.2	0.5	%
f_{OSC}	Oscillation Frequency	Measure waveform at SW pin	240	300	360	kHz
f_{OSC1}	Frequency of Current Limit or Short Circuit Protection	Measure waveform at SW pin	-	50	-	kHz
V_{IH}	EN Pin Input Voltage	Evaluate oscillation at SW pin	2.0	-	-	V
V_{IL}		Evaluate oscillation stop at SW pin	-	-	0.8	
I_{ENH}	EN Pin Input Leakage Current	--	-	20	-	μA
I_{ENL}		--	-	-10	-	μA
I_{OCSET}	OCSET Pin Bias Current	--	75	90	105	μA
T_{SS}	Soft-Start Time	--	0.3	2	5	ms
T_{SHDN}	Thermal shutdown threshold		-	150	-	$^\circ C$
T_{HYS}	Thermal shutdown hysteresis		-	55	-	$^\circ C$
$R_{DS(ON)}$	Internal MOSFET $R_{DS(ON)}$	$V_{IN} = 5V, V_{FB} = 0V$	-	110	150	m Ω
		$V_{IN} = 12V, V_{FB} = 0V$	-	70	100	
EFFI	Efficiency	$V_{IN} = 12V, V_{OUT} = 5V$ $I_{OUT} = 3A$	-	92	-	%
θ_{JA}	Thermal Resistance Junction-to-Ambient	SOP-8L (Note 3)	-	134	-	$^\circ C/W$
θ_{JC}	Thermal Resistance Junction-to-Case	SOP-8L (Note 3)	-	22	-	$^\circ C/W$

Notes: 3. Test condition SOP-8L: Device mounted on FR-4 substrate 2oz copper, minimum recommended pad layout, and single side. For better thermal performance, please arrange larger copper pad of layout for heatsink.

Typical Performance Characteristics

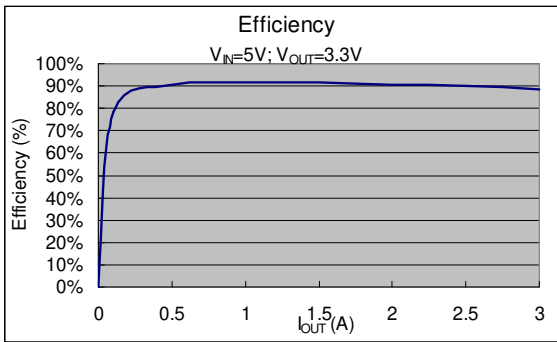
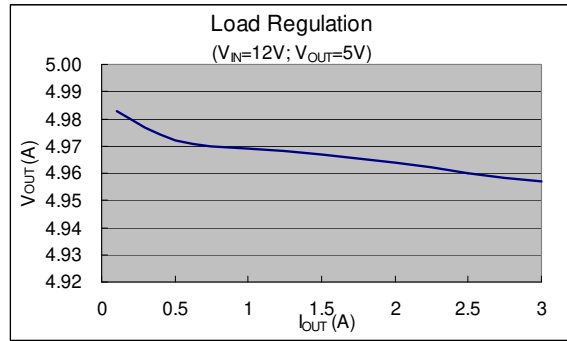
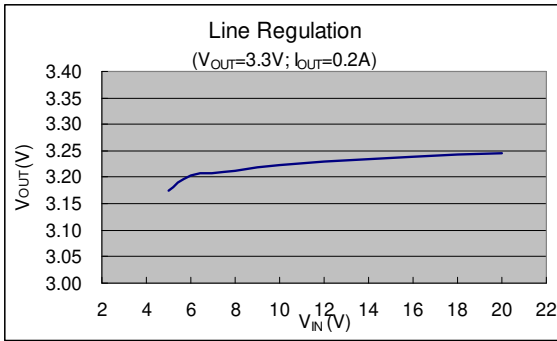
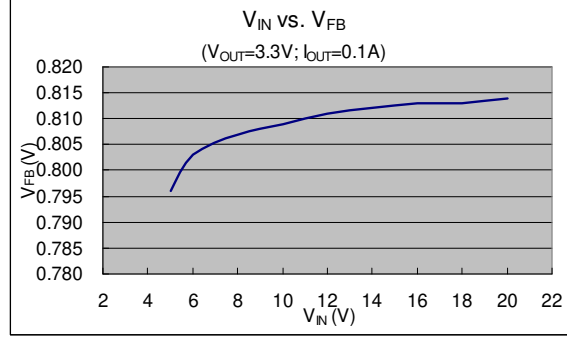
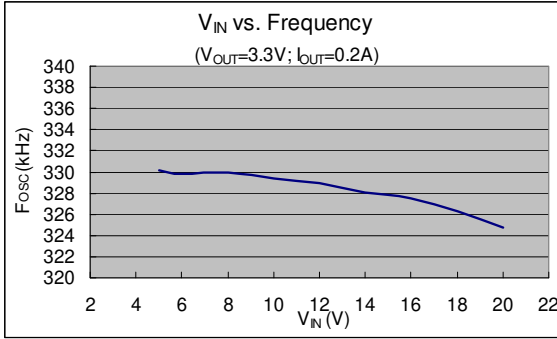

Typical Performance Characteristics (Continued)

AP1530 Vout Ripple
(Vin= 12V; Vout= 3.3V; Iout= 0.1A)

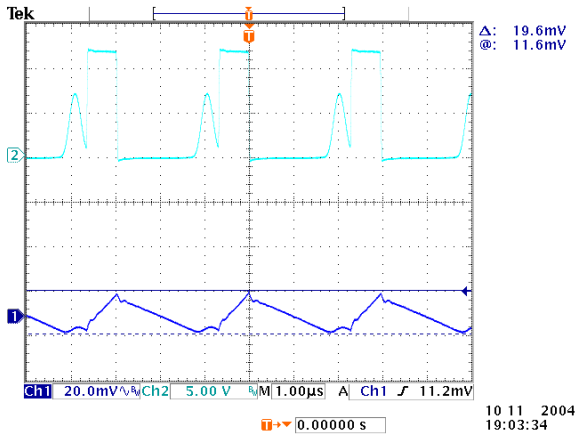

AP1530 Vout Ripple
(Vin= 12V; Vout= 3.3V; Iout= 3A)

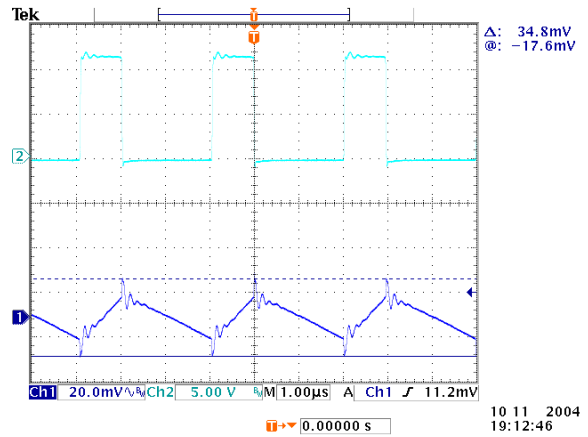

Test Circuit

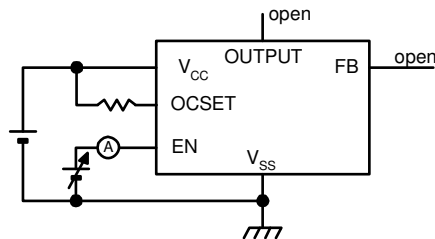

Enable function test

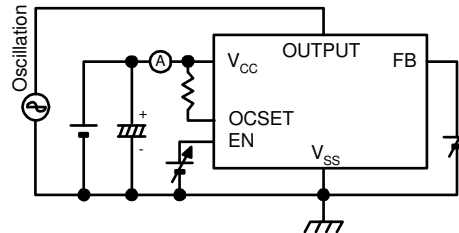

Feedback function test

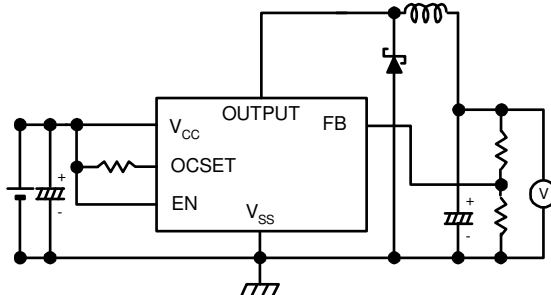

Operation function test

Functional Description

PWM Control

The AP1530 is a DC/DC converter that employs pulse width modulation (PWM) scheme. Its pulse width varies in the range of 0% to 99%, based on the output current loading. The output ripple voltage caused by the PWM high frequency switching can easily be reduced through an output filter. Therefore, this converter provides a low ripple output supply over a broad range of input voltage & output current loading

Under Voltage Lockout

The under voltage lockout circuit of the AP1530 assures that the high-side MOSFET driver remains in the off state whenever the supply voltage drops below 3.3V. Normal operation resumes once V_{CC} rises above 3.5V.

Current Limit Protection

The current limit threshold is set by external resistor R_{OCSET} connected from V_{CC} supply to OCSET pin. The internal sink current I_{OCSET} (90uA typical) across this resistor sets the voltage at OCSET pin. When the PWM voltage is less than the voltage at OCSET, an over-current condition is triggered.

The current limit threshold is given by the following equation:

$$I_{PEAK} \times R_{DS(ON)} = I_{OCSET} \times R_{OCSET}$$

$$I_{PEAK} > I_{OUT(MAX)} + \frac{(\Delta I)}{2}$$

where,

$$\Delta I = \frac{V_{IN} - V_{OUT}}{F_S \times L} \times \frac{V_{OUT}}{V_{IN}}$$

I_{PEAK} is the output peak current; $R_{DS(ON)}$ is the MOSFET ON resistance; F_S is the PWM frequency (300KHz typical). Also, the inductor value will affect the ripple current ΔI .

The above equation is recommended for input voltage range of 5V to 18V. For input voltage lower than 5V or ambient temperature over 100°C, higher R_{OCSET} is recommended.

The recommended minimum R_{OCSET} value is summarized below:

V_{IN} (V)	V_{OUT} (V)	R_{OCSET} (Ω)
4	0.8	3.9K
5	3.3	3.0K
12	5	3.0K
18	12	3.0K

Inductor Selection

For most designs, the operates with inductors of 22 μ H to 33 μ H. The inductor value can be derived from the following equation:

$$L = \frac{V_{IN} - V_{OUT}}{f_s \times \Delta I} \times \frac{V_{OUT}}{V_{IN}}$$

Where ΔI_L is inductor Ripple Current. Large value inductors lower ripple current and small value inductors result in high ripple current. Choose inductor ripple current approximately 15% of the maximum load current 3A, $\Delta I_L=0.45A$. The DC current rating of the inductor should be at least equal to the maximum load current plus half the ripple current to prevent core saturation (3A+0.225A).

Input Capacitor Selection

This capacitor should be located close to the IC using short leads and the voltage rating should be approximately 1.5 times the maximum input voltage. The RMS current rating requirement for the input capacitor of a buck regulator is approximately 1/2 the DC load current. A low ESR input capacitor sized for maximum RMS current must be used. A 470 μ F low ESR capacitor for most applications is sufficient.

Output Capacitor Selection

The output capacitor is required to filter the output voltage and provides regulator loop stability. The important capacitor parameters are the 100KHz Equivalent Series Resistance (ESR), the RMS ripples current rating, voltage rating and capacitance value. For the output capacitor, the ESR value is the most important parameter. The output ripple can be calculated from the following formula.

$$V_{RIPPLE} = \Delta I_L \times ESR$$

The bulk capacitor's ESR will determine the output ripple voltage and the initial voltage drop after a high slew-rate transient.

An aluminum electrolytic capacitor's ESR value is related to the capacitance and its voltage rating. In most case, higher voltage electrolytic capacitors have lower ESR values. Most of the time, capacitors with much higher voltage ratings may be needed to provide the low ESR values required for low output ripple voltage.

PCB Layout Guide

If you need low T_C & T_J or large PD (Power Dissipation), The dual SW pins(5& 6) and Vss pins(7& 8) on the SOP-8L package are internally connected to die pad, The evaluation board should be allowed for maximum copper area at output (SW) pins.

1. Connect FB circuits (R_1 , R_2 , C_1) as closely as possible and keep away from inductor flux for pure V_{FB} .
2. Connect C_3 to V_{cc} and V_{ss} pin as closely as possible to get good power filter effect.
3. Connect R_4 to V_{cc} and OCSET pin as closely as possible.
4. Connect ground side of the C_2 & D_1 & C_4 as closely as possible and use ground plane for best performance.

Functional Description (Continued)

Keep the gap of exposed pads from short circuit.

Top Side Layout Guide

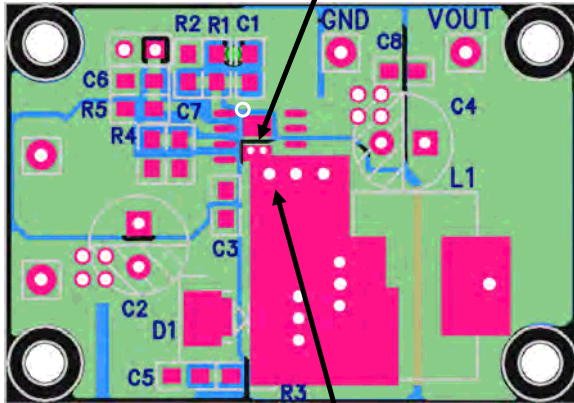

Use vias to conduct the heat into the backside of PCB layer. The heat sink at output (SW) pins should be allowed for maximum solder-painted area.

Bottom Side Layout Guide

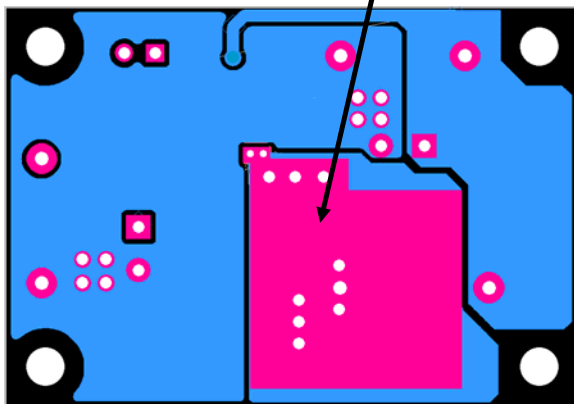

Recommended exposed-pads gap: 30~40mil (0.75~1mm)

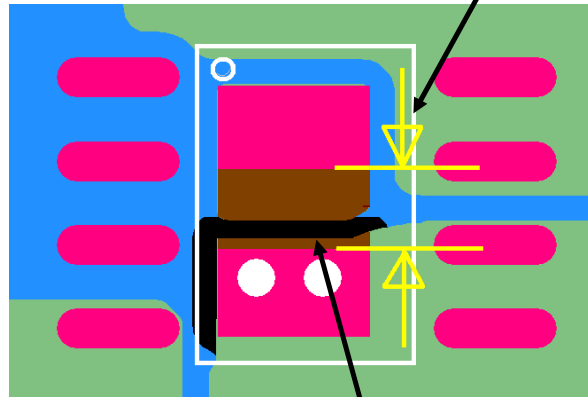

Brown: IC exposed pads.
Red: recommended layout.
Reference pads layout dimension:
Output: 90 x 50 mil
Vss: 90 x 60 mil

Functional Description (Continued)

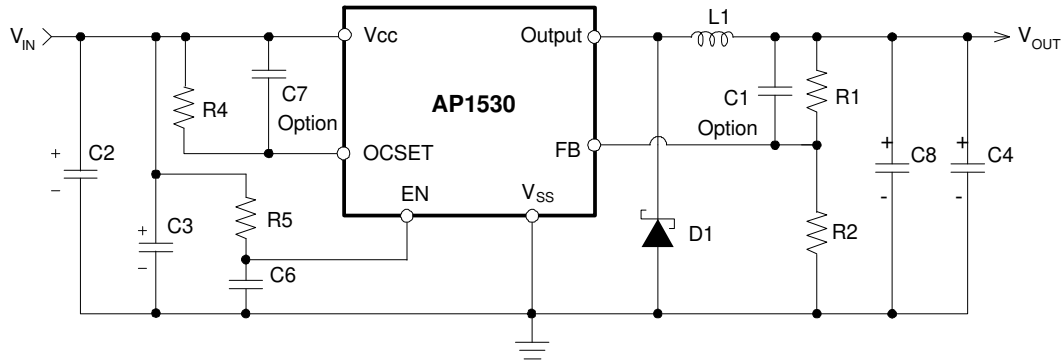
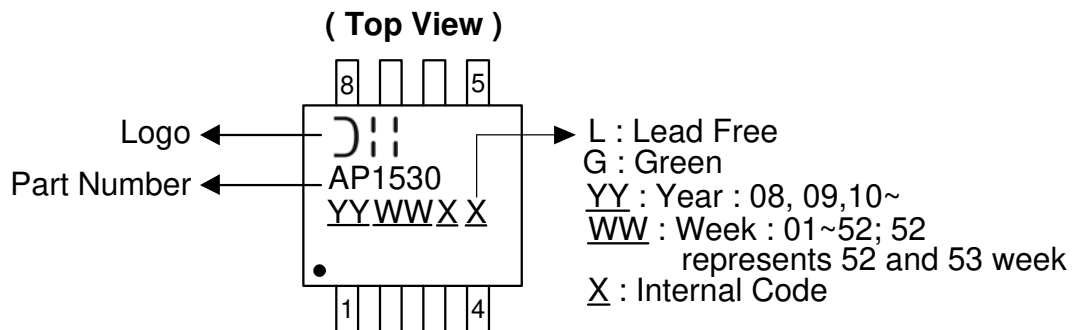

Figure: Layout numbering comparison

Marking Information

(1) SOP-8L



Package Information (All Dimensions in mm)

(1) Package Type: SOP-8L

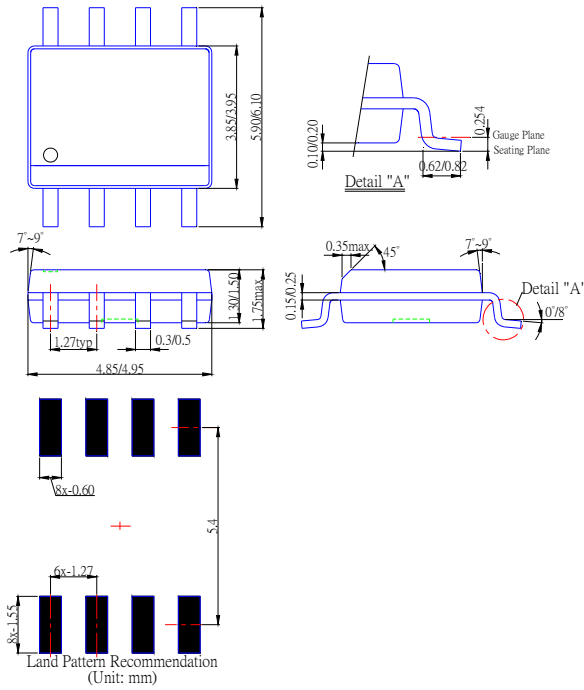

IMPORTANT NOTICE

DIODES INCORPORATED MAKES NO WARRANTY OF ANY KIND, EXPRESS OR IMPLIED, WITH REGARDS TO THIS DOCUMENT, INCLUDING, BUT NOT LIMITED TO, THE IMPLIED WARRANTIES OF MERCHANTABILITY AND FITNESS FOR A PARTICULAR PURPOSE (AND THEIR EQUIVALENTS UNDER THE LAWS OF ANY JURISDICTION).

Diodes Incorporated and its subsidiaries reserve the right to make modifications, enhancements, improvements, corrections or other changes without further notice to this document and any product described herein. Diodes Incorporated does not assume any liability arising out of the application or use of this document or any product described herein; neither does Diodes Incorporated convey any license under its patent or trademark rights, nor the rights of others. Any Customer or user of this document or products described herein in such applications shall assume all risks of such use and will agree to hold Diodes Incorporated and all the companies whose products are represented on Diodes Incorporated website, harmless against all damages.

Diodes Incorporated does not warrant or accept any liability whatsoever in respect of any products purchased through unauthorized sales channel.

Should Customers purchase or use Diodes Incorporated products for any unintended or unauthorized application, Customers shall indemnify and hold Diodes Incorporated and its representatives harmless against all claims, damages, expenses, and attorney fees arising out of, directly or indirectly, any claim of personal injury or death associated with such unintended or unauthorized application.

Products described herein may be covered by one or more United States, international or foreign patents pending. Product names and markings noted herein may also be covered by one or more United States, international or foreign trademarks.

LIFE SUPPORT

Diodes Incorporated products are specifically not authorized for use as critical components in life support devices or systems without the express written approval of the Chief Executive Officer of Diodes Incorporated. As used herein:

A. Life support devices or systems are devices or systems which:

1. are intended to implant into the body, or
2. support or sustain life and whose failure to perform when properly used in accordance with instructions for use provided in the labeling can be reasonably expected to result in significant injury to the user.

B. A critical component is any component in a life support device or system whose failure to perform can be reasonably expected to cause the failure of the life support device or to affect its safety or effectiveness.

Customers represent that they have all necessary expertise in the safety and regulatory ramifications of their life support devices or systems, and acknowledge and agree that they are solely responsible for all legal, regulatory and safety-related requirements concerning their products and any use of Diodes Incorporated products in such safety-critical, life support devices or systems, notwithstanding any devices- or systems-related information or support that may be provided by Diodes Incorporated. Further, Customers must fully indemnify Diodes Incorporated and its representatives against any damages arising out of the use of Diodes Incorporated products in such safety-critical, life support devices or systems.

Copyright © 2009, Diodes Incorporated

www.diodes.com