



Chipsmall Limited consists of a professional team with an average of over 10 year of expertise in the distribution of electronic components. Based in Hongkong, we have already established firm and mutual-benefit business relationships with customers from,Europe,America and south Asia,supplying obsolete and hard-to-find components to meet their specific needs.

With the principle of “Quality Parts,Customers Priority,Honest Operation,and Considerate Service”,our business mainly focus on the distribution of electronic components. Line cards we deal with include Microchip,ALPS,ROHM,Xilinx,Pulse,ON,Everlight and Freescale. Main products comprise IC,Modules,Potentiometer,IC Socket,Relay,Connector.Our parts cover such applications as commercial,industrial, and automotives areas.

We are looking forward to setting up business relationship with you and hope to provide you with the best service and solution. Let us make a better world for our industry!



## Contact us

Tel: +86-755-8981 8866 Fax: +86-755-8427 6832

Email & Skype: info@chipsmall.com Web: www.chipsmall.com

Address: A1208, Overseas Decoration Building, #122 Zhenhua RD., Futian, Shenzhen, China



# Not Recommended for New Design



## AP2006

### 200KHz, PWM Buck DC/DC & Linear Controller

#### ■ Features

- Provides two regulated voltages
  - one PWM Controller( Drive PMOS)
  - one Linear Controller (Drive NPN and NMOS)
- Adjustable version: 1.23+/- 2.5%.
- 250KHz  $\pm 10\%$  fixed switching frequency
- Thermal-shutdown and current-limit protection
- SS/EN Soft-Start/Enable Function.
- Operating voltage can be up to 22V
- Low power standby mode
- **Pb-Free** Package: SOP8,DIP8

#### ■ Applications

- Simple High-efficiency step-down regulator
- On-card switching regulators
- XDSL...

#### ■ Pin Assignments

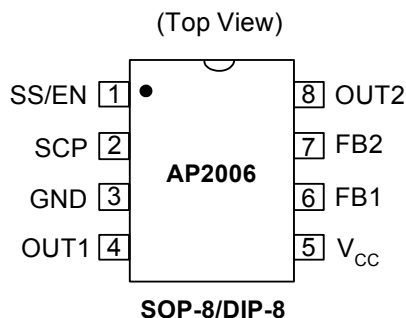

#### ■ General Descriptions

The AP2006 series are monolithic IC's containing a PWM and a linear power controller. The PWM driving a external PMOS. Due to the reduction of the number of external components, board space can be saved easily. The external shutdown function can be controlled by logic level. It switches the IC into the standby mode. The internal compensation provides a good line and load regulation without external component. Short circuit protection prohibits the over current in the output switches. The AP2006 series operate at the switching frequency of 250KHz. Therefore, it is able to use the smaller sized filters than what used to be used with the lower frequency switching regulators. Other features include a guaranteed  $\pm 3\%$  tolerance on output voltage under specified input voltage and output load conditions, and  $\pm 20\%$  on the oscillator frequency. The linear controller is able to drive an external NPN transistor, with 30mA current limit pre-driver. The ICs are available in a standard SOP8/DIP8 package.

#### ■ Pin Descriptions

Name	Description
V <sub>CC</sub>	Operating voltage input
SCP	Short circuit protect
OUT1	Connecting PMOS's Gate
GND	Ground
FB1 FB2	Output voltage feedback control
SS/EN	Soft-start/Enable function
OUT2	Linear Controller Driving External NPN

# Not Recommended for New Design



## AP2006

200KHz, PWM Buck DC/DC & Linear Controller

### ■ Ordering Information

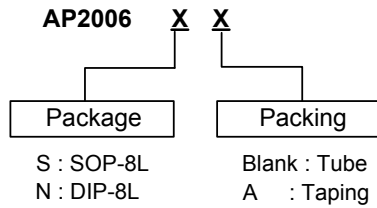

### ■ Block Diagram

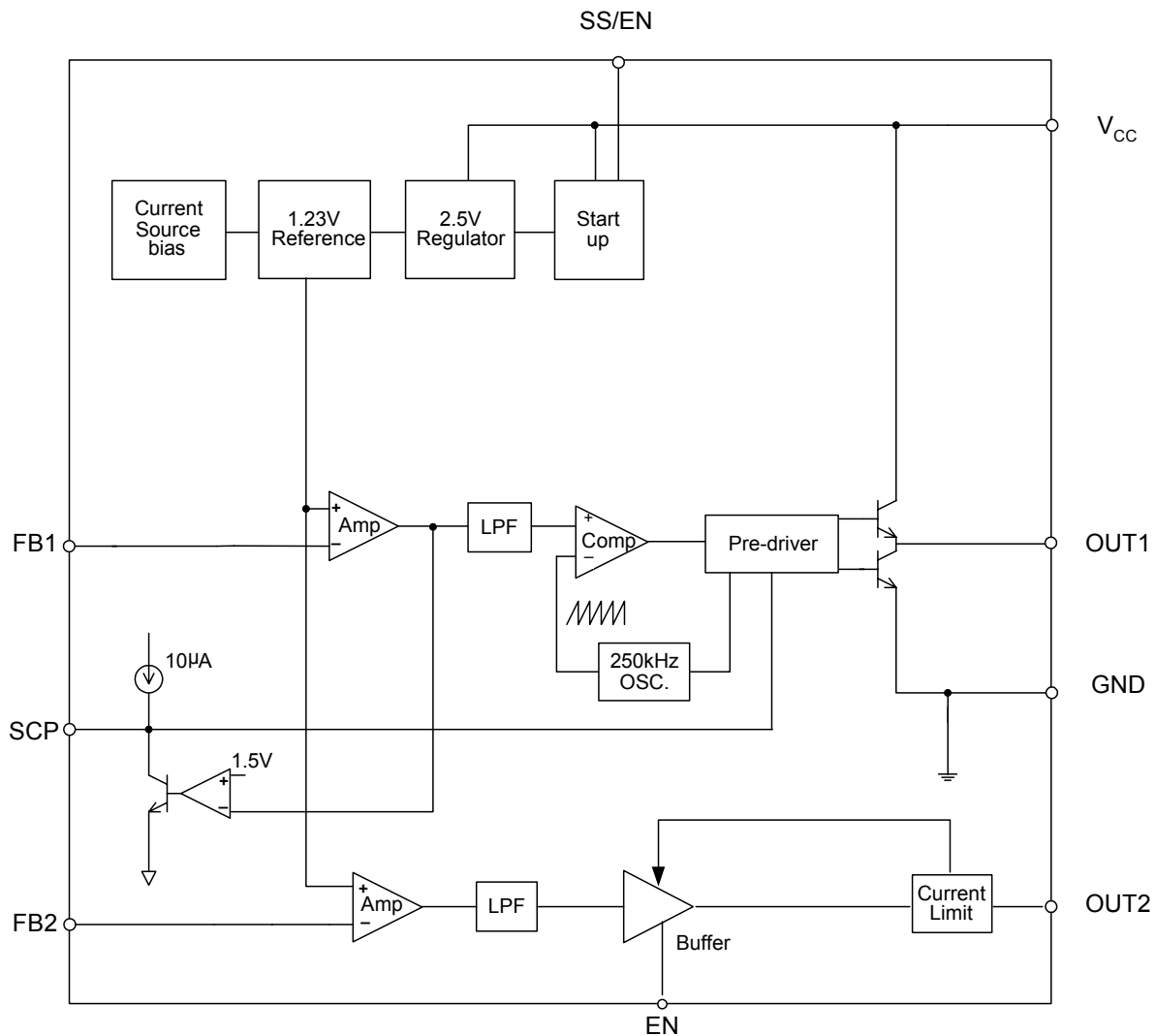

# Not Recommended for New Design



## AP2006

200KHz, PWM Buck DC/DC & Linear Controller

### ■ Absolute Maximum Ratings

Symbol	Parameter	Rating	Unit
V <sub>CC</sub>	Supply Voltage	22	V
V <sub>EN</sub>	EN Pin Input Voltage	-0.3 ≤ V ≤ 22	V
V <sub>FB</sub>	Feedback Pin Voltage	-0.3 ≤ V ≤ 22	V
V <sub>OUT1/2</sub>	Output Voltage to Ground	-0.3 ≤ V ≤ 22	V
P <sub>D</sub>	Power Dissipation	SO8	400
		DIP8	1000
T <sub>ST</sub>	Storage Temperature	-65 to 150	°C
T <sub>OP</sub>	Operating Temperature	-40 to +125°	°C
V <sub>OP</sub>	Operating Voltage	4.5 to 20	V

### ■ Electrical Characteristics (All Output Voltage Versions & Channels)

Unless otherwise specified AP2006, V<sub>in</sub>=12V, I<sub>LOAD</sub> = 0.2A.

Symbol	Parameter	Conditions	Min.	Typ.	Max.	Unit
V <sub>CC</sub>	Supply Voltage		4.5	-	22	V
I <sub>B1/2</sub>	Feedback Bias Current	V <sub>FB1/2</sub> =1.23V(FB1,adj Version)	-	100	1000	nA
F <sub>OSC</sub>	Oscillator Frequency		200	250	300	KHz
V <sub>SAT2</sub>	Saturation Voltage (V <sub>CC</sub> -V <sub>OUT2</sub> )	I <sub>OUT</sub> =20mA(no external NPN or N-MOS) V <sub>FB1</sub> =0V force driver on	-	1.2	-	V
DC	Max. Duty Cycle(ON)	V <sub>FB1</sub> =0V force driver on	-	100	-	%
	Min. Duty Cycle(OFF)	V <sub>FB1</sub> =12V force driver off	-	0	-	%
I <sub>Q</sub>	Quiescent Current (V <sub>CC</sub> )	V <sub>FB1/2</sub> =12V force driver off	-	6	-	mA
V <sub>IL</sub>	Shutdown Logic Input Threshold Voltage	Low (regulator OFF)	-	-	0.2	V
		High (regulator ON)	1.0	-	-	
I <sub>L</sub>	EN pin Input Current	V <sub>LOGIC</sub> =0.5V (regulator OFF)	-	20	-	uA
I <sub>CL2</sub>	Current Limit (OUT2)	V <sub>CC</sub> =5V, V <sub>OUT2</sub> =V <sub>FB2</sub> =0V	25	-	-	mA
V <sub>FB1/2</sub>	AP2006 OUT1 Feedback Voltage	4.75V ≤ V <sub>CC1</sub> ≤ 20V	1.20	1.23	1.26	V
	AP2006 OUT2 Feedback Voltage	3.0V ≤ V <sub>CC2</sub> ≤ 20V	1.17	1.20	1.23	
V <sub>UT</sub>	Upper Threshold Voltage (V <sub>CC</sub> )	I <sub>O(REF)</sub> = 0.1mA T <sub>A</sub> = 25°C	-	4.3	-	V
V <sub>LWT</sub>	Lower Threshold Voltage (V <sub>CC</sub> )		-	4.1	-	V
V <sub>HT</sub>	Hysteresis (V <sub>CC</sub> )		-	200	-	mV
V <sub>IT</sub>	Input Threshold Voltage (SCP)	T <sub>A</sub> = 25°C	0.60	0.67	0.75	V
V <sub>STB</sub>	Standby Voltage (SCP)	No pull up	100	130	160	mV
V <sub>LT</sub>	Latched Input Voltage (SCP)	No pull up	-	50	100	mV
I <sub>SCP</sub>	Input (source) Current (SCP)	V <sub>I</sub> = 0.7V, T <sub>A</sub> = 25°C	-5	-10	-20	μA
I <sub>LEAK</sub>	Leakage current (OUT1)	FB=12V	-	-	10	μA
I <sub>DRV</sub>	Sink Current (OUT1)	V <sub>IN</sub> = 12V	-	300	-	mA
	Source Current (OUT1)	V <sub>IN</sub> = 12V	-	200	-	mA
V <sub>SAT</sub>	Output Saturation Voltage (OUT1)	I <sub>O</sub> = 10 mA	-	1.0	1.5	V
I <sub>SC</sub>	Short-circuit Output Current (OUT1)	V <sub>O</sub> = 6V, V <sub>FB</sub> =12V	-	120	-	mA
V <sub>SS</sub>	Soft-start Voltage		-	2.4	-	V
I <sub>SS</sub>	Constant Charge Current		-	10	-	μA

# Not Recommended for New Design



AP2006

200KHz, PWM Buck DC/DC & Linear Controller

## ■ Typical Application Circuit

(1)  $V_{OUT2}$  Drive NPN

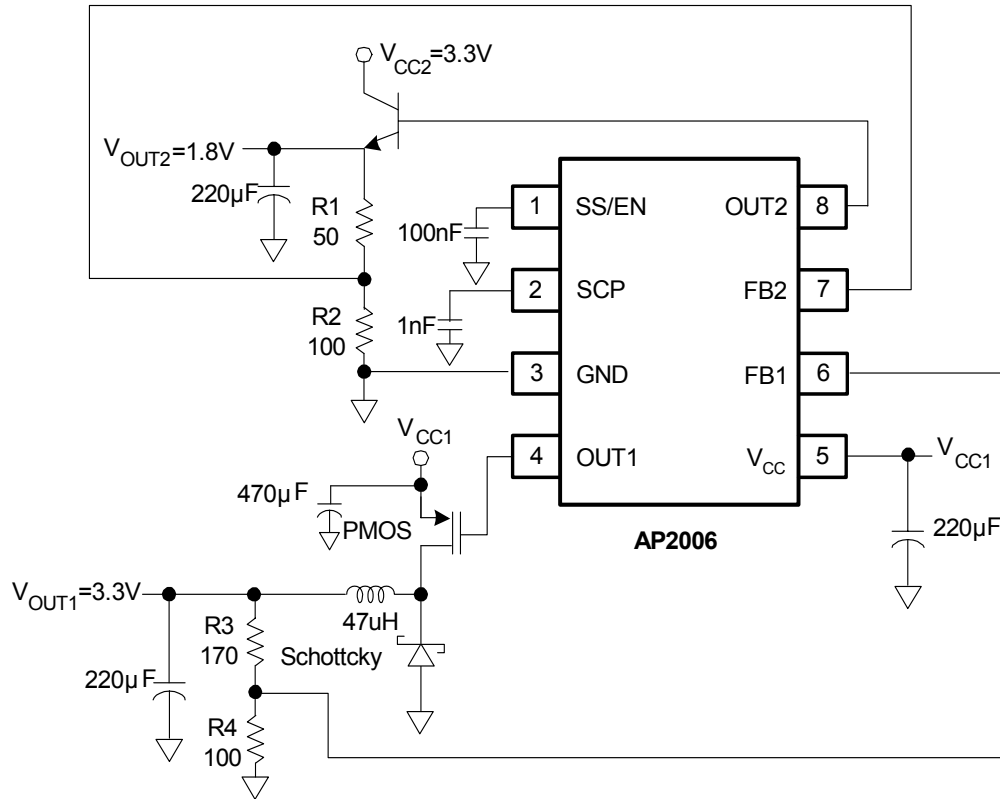

$$\text{AP2006} \Rightarrow V_{OUT1} = 1.25 \cdot (1 + R3/R4)$$
$$V_{OUT2} = 1.25 \cdot (1 + R1/R2)$$

# Not Recommended for New Design



AP2006

200KHz, PWM Buck DC/DC & Linear Controller

## ■ Typical Application Circuit (Continued)

### (2) $V_{OUT2}$ Drive NMOS

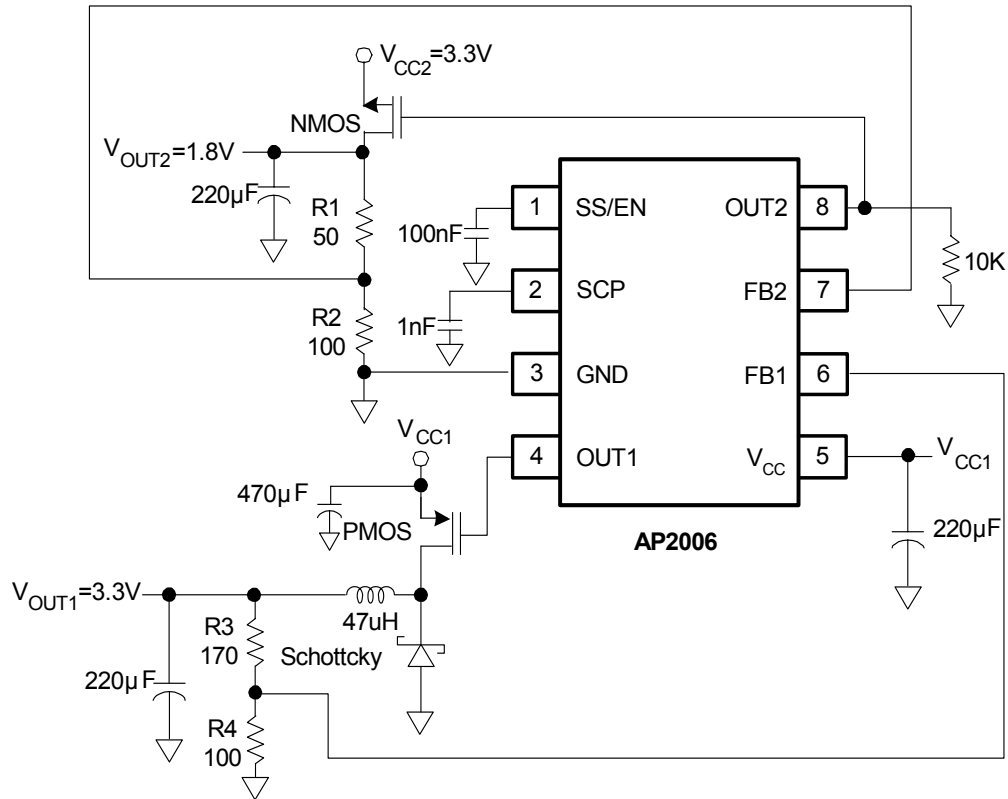

$$\begin{aligned} \text{AP2006} \Rightarrow V_{OUT1} &= 1.25 \cdot (1 + R3/R4) \\ V_{OUT2} &= 1.25 \cdot (1 + R1/R2) \end{aligned}$$

# Not Recommended for New Design



**AP2006**

200KHz, PWM Buck DC/DC & Linear Controller

## ■ Marking Information

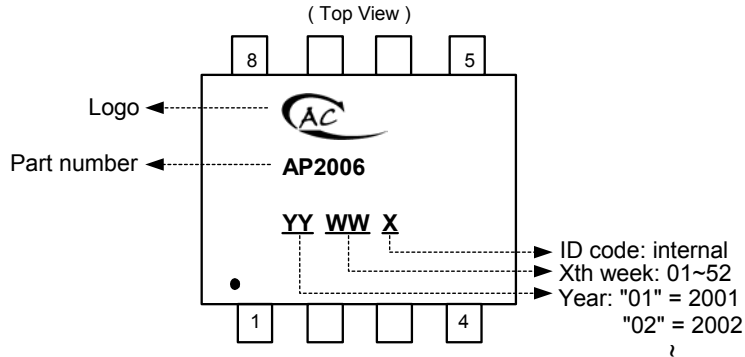

## ■ Package Information

(1) SOP-8L

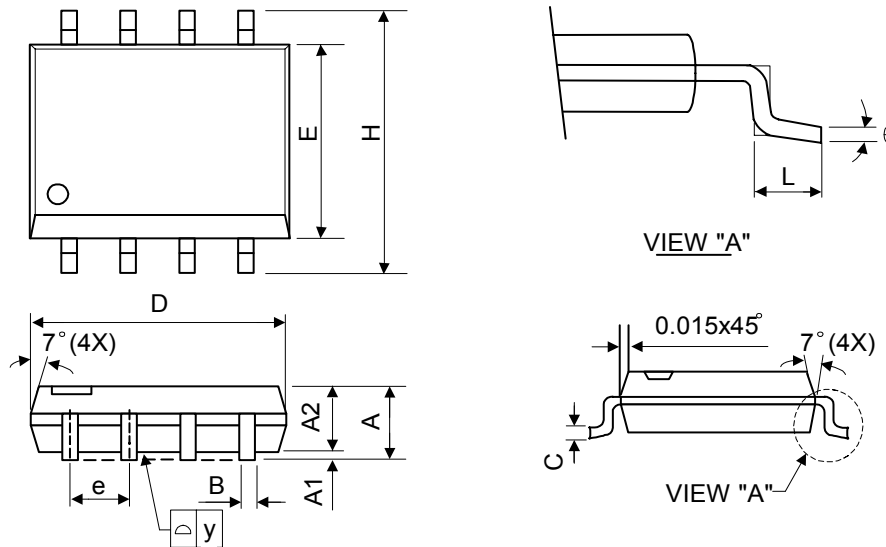

Symbol	Dimensions In Millimeters			Dimensions In Inches		
	Min.	Nom.	Max.	Min.	Nom.	Max.
A	1.40	1.60	1.75	0.055	0.063	0.069
A1	0.10	-	0.25	0.040	-	0.100
A2	1.30	1.45	1.50	0.051	0.057	0.059
B	0.33	0.41	0.51	0.013	0.016	0.020
C	0.19	0.20	0.25	0.0075	0.008	0.010
D	4.80	5.05	5.30	0.189	0.199	0.209
E	3.70	3.90	4.10	0.146	0.154	0.161
e	-	1.27	-	-	0.050	-
H	5.79	5.99	6.20	0.228	0.236	0.244
L	0.38	0.71	1.27	0.015	0.028	0.050
y	-	-	0.10	-	-	0.004
θ	0°	-	8°	0°	-	8°

# Not Recommended for New Design



**AP2006**

200KHz, PWM Buck DC/DC & Linear Controller

(2) DIP-8L

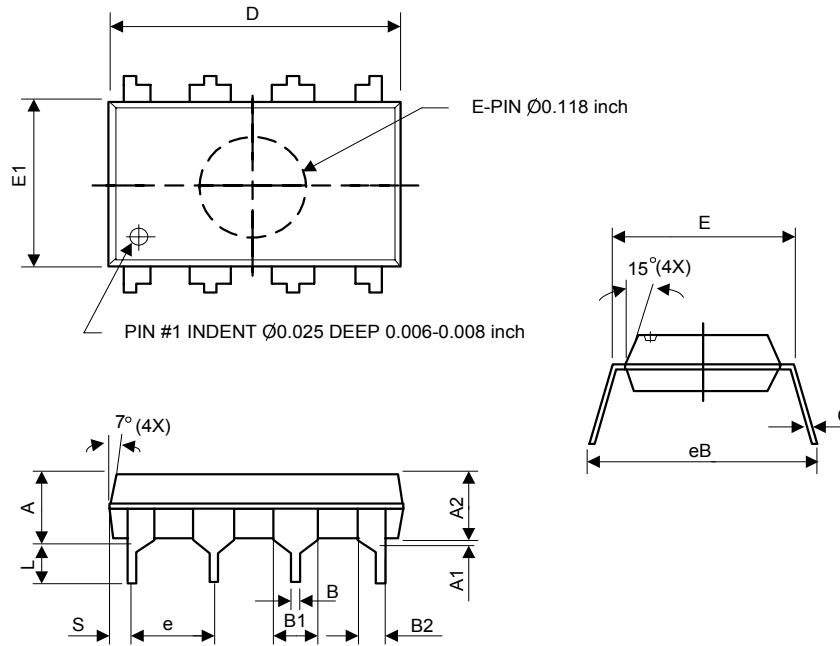

Symbol	Dimensions in millimeters			Dimensions in inches		
	Min.	Nom.	Max.	Min.	Nom.	Max.
A	-	-	5.33	-	-	0.210
A1	0.38	-	-	0.015	-	-
A2	3.1	3.30	3.5	0.122	0.130	0.138
B	0.36	0.46	0.56	0.014	0.018	0.022
B1	1.4	1.52	1.65	0.055	0.060	0.065
B2	0.81	0.99	1.14	0.032	0.039	0.045
C	0.20	0.25	0.36	0.008	0.010	0.014
D	9.02	9.27	9.53	0.355	0.365	0.375
E	7.62	7.94	8.26	0.300	0.313	0.325
E1	6.15	6.35	6.55	0.242	0.250	0.258
e	-	2.54	-	-	0.100	-
L	2.92	3.3	3.81	0.115	0.130	0.150
eB	8.38	8.89	9.40	0.330	0.350	0.370
S	0.71	0.84	0.97	0.028	0.033	0.038