



Chipsmall Limited consists of a professional team with an average of over 10 year of expertise in the distribution of electronic components. Based in Hongkong, we have already established firm and mutual-benefit business relationships with customers from,Europe,America and south Asia,supplying obsolete and hard-to-find components to meet their specific needs.

With the principle of “Quality Parts,Customers Priority,Honest Operation,and Considerate Service”,our business mainly focus on the distribution of electronic components. Line cards we deal with include Microchip,ALPS,ROHM,Xilinx,Pulse,ON,Everlight and Freescale. Main products comprise IC,Modules,Potentiometer,IC Socket,Relay,Connector.Our parts cover such applications as commercial,industrial, and automotives areas.

We are looking forward to setting up business relationship with you and hope to provide you with the best service and solution. Let us make a better world for our industry!



## Contact us

Tel: +86-755-8981 8866 Fax: +86-755-8427 6832

Email & Skype: info@chipsmall.com Web: www.chipsmall.com

Address: A1208, Overseas Decoration Building, #122 Zhenhua RD., Futian, Shenzhen, China





# AP2061AEC

## 2.0A High-side LED Driver for Camera Flash with I<sup>2</sup>C

### 1. General Description

The AP2061 is a white LED driver IC for camera flash applications of portable equipment. The device integrates a current mode synchronous boost DC-DC converter and maximum 2A current sources. The internal boost DC-DC converter integrates a switching FET and synchronous rectifier, and supports a small size multilayer inductor with 4MHz switching frequency. The internal current sources allow for grounded cathode connections for easier heat dissipation and simple LED arrangement. The AP2061 includes eight protections that are LED thermal detection, inductor current limitation, input voltage detection, over voltage protection, under voltage lock out, device thermal protection, LED open/short protection and output-ground short protection to avoid significant system problems. Flash current, torch current, inductor limit current and flash on-time is programmable through I<sup>2</sup>C interface. The AP2061 is housed in a small size package (16-pin CSP: 1.56mm x 1.56mm, 0.4mm pitch), saving much space on a system board.

### 2. Features

- **Power Supply Voltage:** **VIN = 2.7V to 5.5V**
- **LED Current:** **Total I<sub>LED</sub> = 2.0A (max), I<sub>LED</sub>/ch = 1.0A/ch (max)**
- **High-Side Current Source**
- **High Efficiency**
- **Switching Frequency:** **Frequency= 4.0 MHz**
  - **Support small size inductor**
- **Automatically Selected Working Mode (DC-DC↔Bypass)**
- **Synchronization With RF power-Amplifier Pulse**
- **Input Voltage Detection Function**
- **I<sup>2</sup>C Function:**
  - **Flash LED current setting**
  - **Torch LED current setting**
  - **Flashing on-time setting**
  - **Current limit value setting**
  - **LED thermal detection voltage setting**
  - **Battery detection voltage setting**
  - **Error read support**
- **Protection Function:**
  - **LED thermal detection**
  - **Inductor current limit**
  - **Input voltage detection**
  - **Over voltage protection (OVP)**
  - **Under voltage lock out (UVLO)**
  - **Thermal shutdown**
  - **LED open/short**
  - **Output-ground short**
- **Operation Temperature :** **Ta: -30 to 85°C**
- **Package:** **16-pin CSP (1.56 x 1.56mm, 0.4mm pitch)**

<b>3. Table of Contents</b>
-----------------------------

1. General Description .....	1
2. Features .....	1
3. Table of Contents .....	2
4. Block Diagram .....	3
5. Pin Configurations and Functions .....	4
■ Ordering Guide .....	4
■ Pin Configurations .....	4
■ Function .....	4
6. Absolute Maximum Ratings .....	5
7. Recommended Operating Conditions .....	5
■ Thermal Properties .....	5
8. DC Characteristics .....	6
9. Electrical Characteristics .....	6
10. Digital Characteristics .....	7
■ Control Interface Timing .....	7
■ Timing Diagram .....	7
11. Functional Descriptions .....	8
■ Protection Function .....	8
■ LED Temperature Detection Function .....	9
■ Recommend Sequence Examples .....	10
■ Typical Performance Characteristics .....	15
■ Serial Control Interface .....	17
12. Register Map .....	20
■ Register Map .....	20
■ Register Definitions .....	20
13. Recommended External Circuits .....	25
14. Package .....	26
■ Outline Dimensions .....	26
■ PCB Layout Example .....	26
■ Marking .....	27
15. Revise History .....	28
IMPORTANT NOTICE .....	29

**4. Block Diagram**

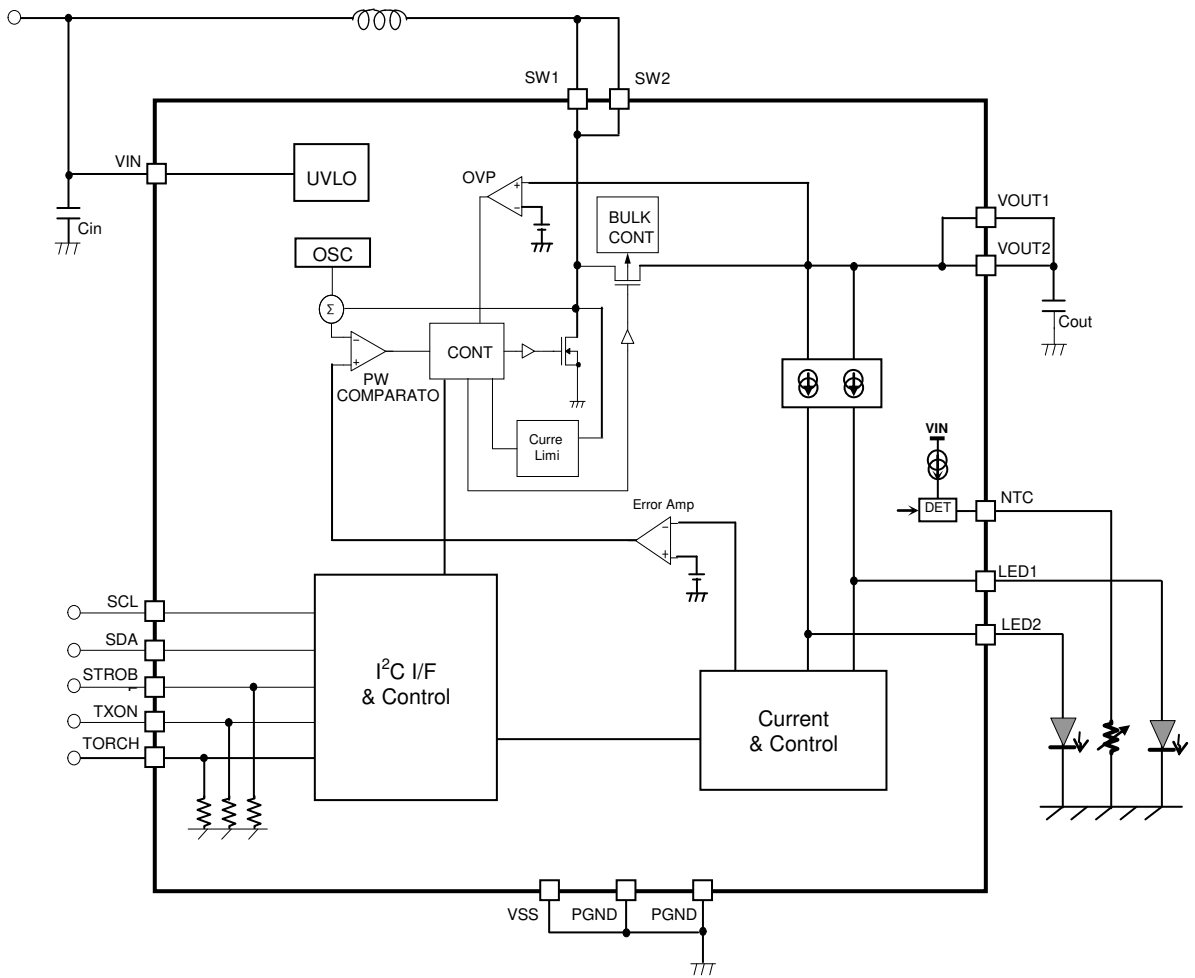

Figure 1. AP2061 Block Diagram

## 5. Pin Configurations and Functions

### ■ Ordering Guide

AP2061AEC      Ta = -30 to 85°C      16-pin CSP

### ■ Pin Configurations

16-pin CSP (1.56mm x 1.56mm, 0.4mm pitch)

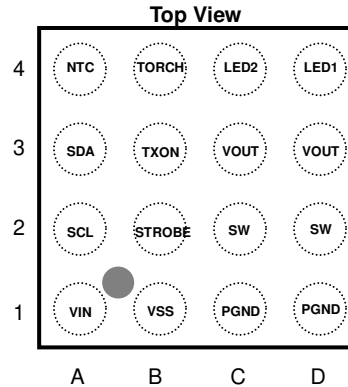

### ■ Function

No.	Pin Name	I/O	Function
C3, D3	VOUT	O	Voltage Output
C2, D2	SW	I	Connect this pin to a coil.
A1	VIN	I	Connect this pin to a battery.
C1, D1	PGND	-	Power Ground
B1	VSS	-	Analog Ground
D4	LED1	O	LED Connect1 (This pin should be open when unused)
C4	LED2	O	LED Connect2 (This pin should be open when unused)
A4	NTC	O	LED Temperature Detection Pin (connect to NTC thermistor) (This pin should be connected to ground when unused)
B3	TXON	I	Synchronization Input Pin for RF Transmission Signal (This pin should be connected to ground when unused) Pull-down resistor= 300kΩ @ typ
A2	SCL	I	I <sup>2</sup> C Clock Input Pin
A3	SDA	I/O	I <sup>2</sup> C Data Input/output Pin
B2	STROBE	I	Flashing Control Signal Input Pin (This pin should be connected to ground when unused) Pull-down resistor= 300kΩ @ typ
B4	TORCH	I	Torching Control Signal Input Pin (This pin should be connected to ground when unused) Pull-down resistor= 300kΩ @ typ

Note 1. Both VOUT pins (No. C3 and D3) must be connected together.

Note 2. Both SW pins (No. C2 and D2) must be connected together.

## 6. Absolute Maximum Ratings

(PGND=VSS=0V; (Note 3))

Parameter	Symbol	min	max	Unit
Input Voltage VIN pin (Vbatt)	VIN	-0.3	6.5	V
Input Voltage SW pin	VIN	-0.3	6.5	V
TXON, STROBE, SCL, SDA, TORCH pins	V <sub>MAX</sub>	-0.3	VIN+0.3 (Note 4)	V
LED Total Current	I <sub>LED</sub>	-	2	A
Junction Temperature	T <sub>j</sub>	-	125	°C
Storage Temperature	T <sub>STG</sub>	-55	150	°C

Note 3. All voltages are with respect to ground. PGND and VSS pins should be connected to the same ground.

Note 4. The maximum value is lower value between (VIN+0.3)V and 6.5V.

WARNING: Operation at or beyond these limits may result in permanent damage to the device.  
Normal operation is guaranteed at these extremes.

## 7. Recommended Operating Conditions

(PGND=VSS=0V; (Note 3))

Parameter	Symbol	min	typ	max	Unit
Input Voltage (VIN pin)	VIN	2.7	3.7	5.5	V
Operation Temperature	T <sub>a</sub>	-30	25	85	°C

Note: When 4.7V < VIN < 5.5V, the AP2061 is able to perform normally in a condition that protection functions will not work. However the analog characteristics cannot be guaranteed.

Recommend Example (in the case of using recommended parts): T<sub>a</sub> ≤ 50°C

Table 1. Recommend condition

LED Current	VIN pin Voltage	LED VF	Flashing time
1.3A	≥ 2.9V	≤ 4.2V @ 1.3A	≤ 300ms
1.6A	≥ 3.3V	≤ 4.2V @ 1.6A	≤ 300ms
2.0A	≥ 3.4V	≤ 3.8V @ 2.0A	≤ 100ms
2.0A	≥ 3.5V	≤ 4.0V @ 2.0A	≤ 100ms
2.0A	≥ 3.6V	≤ 4.2V @ 2.0A	≤ 100ms

### ■ Thermal Properties

Parameter	Symbol	typ	Unit
Thermal Junction-to-Ambient Resistance (Note 5)	θ <sub>JA</sub>	65	°C/W

Note 5. This value is the result with a 4-layer FR-4 test board (40mm x 40mm x 1.6mm).

Ambient temperature is 25°C.

Thicknesses of copper layers: 18um / 35um / 35um / 18um.

Densities of copper layers: > 80% / 80% / 80% / 80%.



### 8. DC Characteriistis

(Ta= -30 to 85°C; VIN=2.7 to 5.5V), SCL, SDA, TXON, STROBE, TORCH pins.

Parameter	Symbol	min	typ	max	Unit
High-Level Input Voltage	V <sub>IH</sub>	1.2	-	V <sub>IN</sub>	V
Low-Level Input Voltage	V <sub>IL</sub>	-	-	0.4	V
Low-Level Output Voltage (I <sub>out</sub> = 3mA) (SDA pin)	V <sub>OL</sub>	-	-	0.4	V
Input Leakage Current1 (SCL, SDA pins)	I <sub>IN1</sub>	-2	-	2	μA
Pull-down Resistance (TXON, STROBE, TORCH pins)	R <sub>IN</sub>	100	300	700	kΩ

### 9. Electrical Characteristics

(PGND=VSS=0V (Note 3), VIN=2.7 to 4.7V, Ta=-30 to 85 °C, Recommend Parts, unless otherwise specified)

Parameter	Symbol	min	typ	max	Unit	Conditions
Power-down Current	I <sub>SB</sub>		1.0	5.0	μA	LED1, LED2 bits = "0" SCL, SDA pins= VIN VIN= 3.7V
Quiescent Current (from VIN pin)	I <sub>Q</sub>		1	1.5	mA	LED1=LED2=30mA setting VOUT= 4.5V
LED Current Accuracy1 (flash mode)	I <sub>ACCU1</sub>	-8		8	%	I <sub>LED1</sub> =I <sub>LED2</sub> = 800mA (VIN=3.7V, Ta=25 °C)
LED Current Accuracy2 (flash mode)	I <sub>ACCU2</sub>	-10		10	%	I <sub>LED1</sub> =I <sub>LED2</sub> = 800mA
LED Current Accuracy3 (torch mode)	I <sub>ACCU3</sub>	-12		12	%	I <sub>LED1</sub> =I <sub>LED2</sub> = 200mA
Current Source Dropped Voltage 1 (VOUT-(LED1 or 2) pin voltage)	V <sub>DROP1</sub>		0.35	0.38	V	2.8V≤V <sub>LED1</sub> , V <sub>LED2</sub> ≤4.2V I <sub>LED1</sub> =I <sub>LED2</sub> = 0.03to0.8A , CB bit= "0"
Current Source Dropped Voltage 2 (VOUT-(LED1 or 2) pin voltage)	V <sub>DROP2</sub>		0.43	0.46	V	2.8V≤V <sub>LED1</sub> , V <sub>LED2</sub> ≤4.2V I <sub>LED1</sub> =I <sub>LED2</sub> = 1A , CB bit= "1"
Over Voltage Protection (Hysteresis)	OVP	4.9	5.1 (0.21)	5.3	V	
Under Voltage Lock Out (UVLO) (Hysteresis)	V <sub>UVLO</sub>	2.4	2.5 (0.1)	2.6	V	
Boost Frequency	F <sub>BOOST</sub>	2.6	4.0	4.4	MHz	
Timeout Time Accuracy	T <sub>OUTA</sub>	-10		35	%	
Inductor Current Limit Accuracy	I <sub>LIMITA</sub>	-15		15	%	Ta=25°C, VIN=3.7V
Flash to Torch LED Current Setting Time	T <sub>FtoT</sub>			5	μs	TXON pin= "L" to "H" I <sub>LED1</sub> =I <sub>LED2</sub> =1000mA to 30mA
NTC pin Detection Accuracy	V <sub>DETA</sub>	-8		8	%	
NTC pin current	V <sub>Current</sub>	32	35	38	μA	
VIN Detection Accuracy	V <sub>DETA</sub>	-5		5	%	
VIN Detection Hysteresis	V <sub>DETH</sub>		0.1		V	
Thermal Protection Temperature (Hysteresis)	T <sub>reg</sub> T <sub>regH</sub>	140	170 (50)		°C	

**10. Digital Characteristics**

**■ Control Interface Timing**

(Ta = -30 to 85°C; VIN = 2.7 to 5.5V)

Parameter	Symbol	min	typ	max	Unit
SCL Clock Frequency	F <sub>SCL</sub>	-	-	400	kHz
Bus Free Time Between Transmissions	t <sub>BUF</sub>	1.3	-	-	μs
Start Condition Hold Time (prior to first clock pulse)	t <sub>HD:STA</sub>	0.6	-	-	μs
Clock Low Time	t <sub>LOW</sub>	1.3	-	-	μs
Clock High Time	t <sub>HIGH</sub>	0.6	-	-	μs
Setup Time for Repeated Start Condition	t <sub>SU:STA</sub>	0.6	-	-	μs
SDA Hold Time from SCL Falling (Note 6)	t <sub>HD:DAT</sub>	0	-	-	μs
SDA Setup Time from SCL Rising	t <sub>SU:DAT</sub>	0.1	-	-	μs
Rise Time of Both SDA and SCL Lines	t <sub>R</sub>	-	-	0.3	μs
Fall Time of Both SDA and SCL Lines	t <sub>F</sub>	-	-	0.3	μs
Setup Time for Stop Condition	t <sub>SU:STO</sub>	0.6	-	-	μs
Capacitive load on bus	C <sub>b</sub>	-	-	400	pF
Pulse Width of Spike Noise Suppressed by Input Filter	t <sub>SP</sub>	0	-	50	ns

Note 6. Data must be held long enough to bridge the 300ns transition time of SCL.

**■ Timing Diagram**

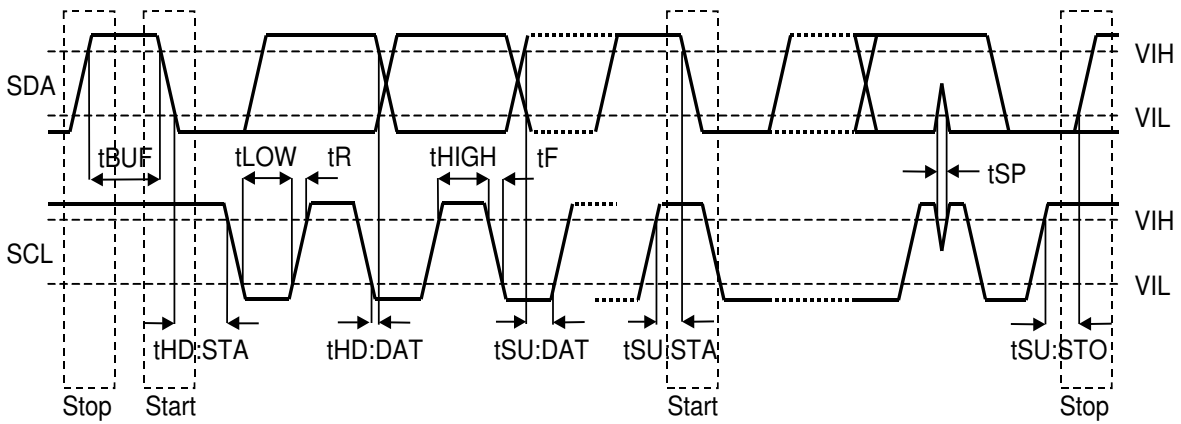

Figure 2. I<sup>2</sup>C Bus Mode Timing



## 11. Functional Descriptions

The AP2061 is a synchronically boost DC-DC converter supporting a 4MHz switching frequency. The AP2061 can drive LEDs which are connected to LED1 and LED2 pins with internal regulated current sources. The regulated current sources (high-side current sources) use PMOS FETs, allowing the LEDs to be directly connected to ground and providing better LED heat dissipation and simpler LED arrangement. The AP2061 can automatically regulate the output voltage with different LED Forward Voltages (VF).

The AP2061 integrates a TXON input which can be used to change the LED current from flash mode to torch mode immediately in order to reduce the battery current during RF transmission or high current events.

### ■ Protection Function

To prevent system troubles and device damages, the AP2061 has protection functions as shown below.

(PGND=VSS=0V; (Note 3), VIN=3.7V, Ta=25°C, Recommend Parts, unless otherwise specified)

No	Protection	Protection Enable Condition	Device status	Recovering Condition
1	LED thermal protection (refer to next page)	NTC pin voltage < setting voltage (DET[2:0])	All circuits power-down Address = "06H", NTC = "1"	Set LED1= LED2= "0" (Note 7)
2	Over current protection (OCP)	Inductor peak current > setting current (LIMIT[1:0])	Switching NMOSFET change to off when inductor current reach to limited current	Return automatically (1 cycle detected)
3	Battery voltage detection	In the case of flashing VIN pin voltage < setting voltage (VIN[1:0])	Change to torch mode	Next flash signal, Return automatically VIN pin voltage >setting voltage+0.1V
4	Over Voltage Protection (OVP)	VOUT pin voltage > 5.1V	Boost circuit power-down	Return automatically VOUT pin voltage < 5.1V-0.215V
5	Under Voltage Lock Out (UVLO)	VIN pin voltage < 2.5V	All circuits power-down Address = "06H", UVLO = "1"	Set LED1= LED2= "0" again
6	Thermal Shut-Down (TSD)	Device temperature > 170 °C	TSDSEL bit= "0": All circuits power-down Address = "06H", TSD = "1" TSDSEL bit = "1": Boost circuit and current source circuit power-down	TSDSEL bit= "0": Set LED1 = LED2 = "0" again TSDSEL bit = "1": Return automatically Device temperature >120 °C
7	LED1, LED2 pin in the state of open or short to GND	(VOUT-LED1 < 0.1V or VOUT-LED2 < 0.1V) and OVP is detected  LED1 pin < 1.0V or LED2 < 1.0V for 20us	All circuit power-down Address = "06H", LO = "1"  All circuit power-down Address = "06H", LS = "1"	Set LED1= LED2= "0" (Note 7)
8	VOUT short to GND	When VOUT pin voltage < 1.0V or in the case of start-up, If VOUT voltage < VIN-0.1V, 1ms after Mini PON (COUT ≤ 10μF)	All circuit power-down Address = "06H", VOS = "1"	

Note 7. The AP2061 can recover from all circuit power-down by setting LED1 bit = LED2 bit= "1", after setting LED1 bit = LED2 bit = "0" once. In this case, the register setting should be written again since registers are reset. The AP2061 will be powered down again unless removing all error statuses.

■ LED Temperature Detection Function

The AP2061 can detect LED temperature with a NTC thermistor (Negative Temperature Coefficient Thermistor) which is connected to the NTC pin. The current which flows at the NTC thermistor is 35uA.

Protection	Protection Enable Condition	Device Status	Recovering Condition
LED1, LED2 temperature protection	NTC pin voltage < setting voltage(DET[2:0])	All circuits power-down Address= "06H", NTC= "1"	Set LED1= LED2= "0"

Note 8. The parasitic capacitance of the NTC pin should be lower than 50pF.

Example)

NTC thermistor: NCP15WM154 (150kΩ @ 25°C, B constant = 4582, 1005 size, Murata Manufacturing)

NCP15WM224 (220kΩ @ 25°C, B constant = 4582, 1005 size, Murata Manufacturing)

Formula:  $R = R_0 \cdot \exp(B \cdot (1/T - 1/T_0))$

R: Resistance with ambient temperature T (K)

K: kelvin

R<sub>0</sub>: Resistance with ambient temperature T<sub>0</sub> (K)

Detection Voltage V @ typ (set by resistor)	0.60	0.67	0.74	0.81	0.88	0.95	1.02
Detection Resistance (kΩ)	17.1	19.1	21.1	23.1	25.1	27.1	29.1
Detection Temperature (°C) (when using 150kΩ)	74	71	69	66	64	62	61
Detection Temperature (°C) (when using 220kΩ)	84	82	79	76	74	72	70

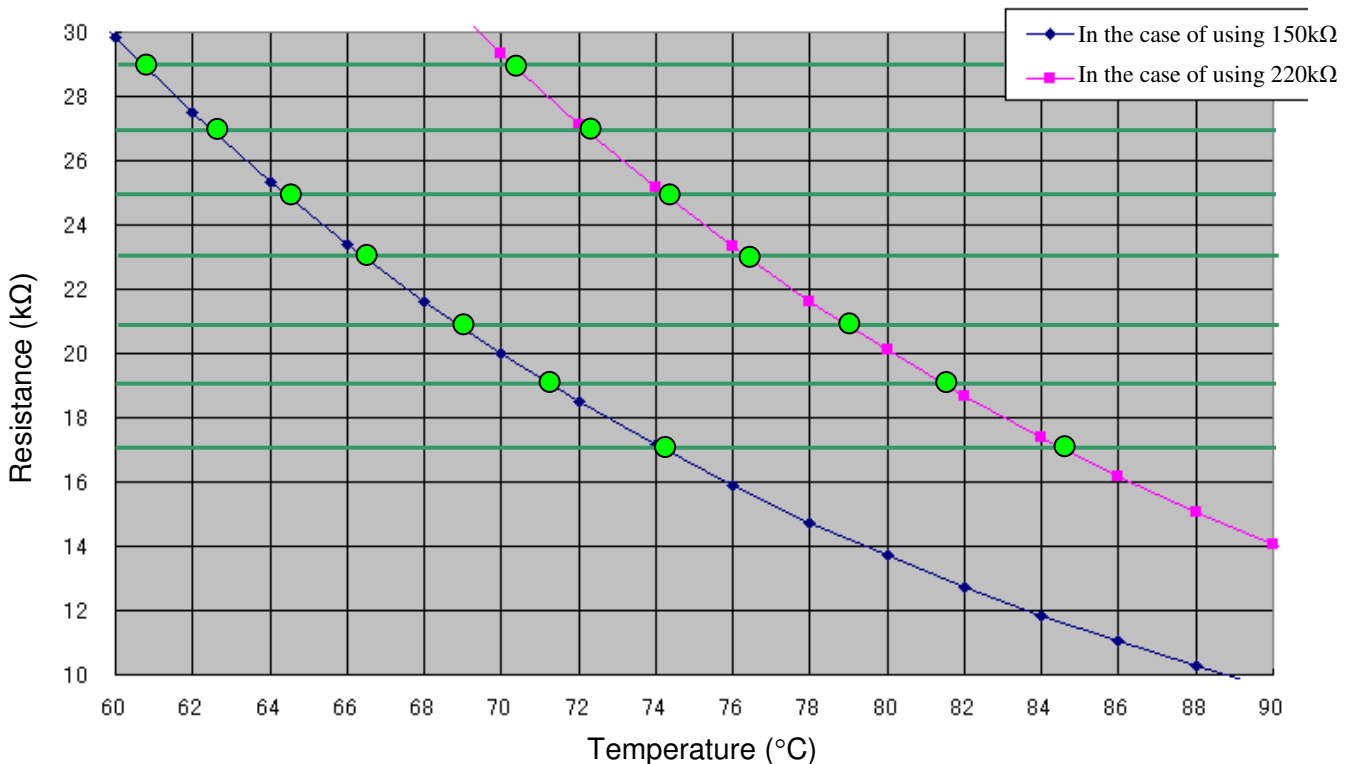

Figure 3. LED Temperature



## 2) Flashing Sequence (EDGE Control)

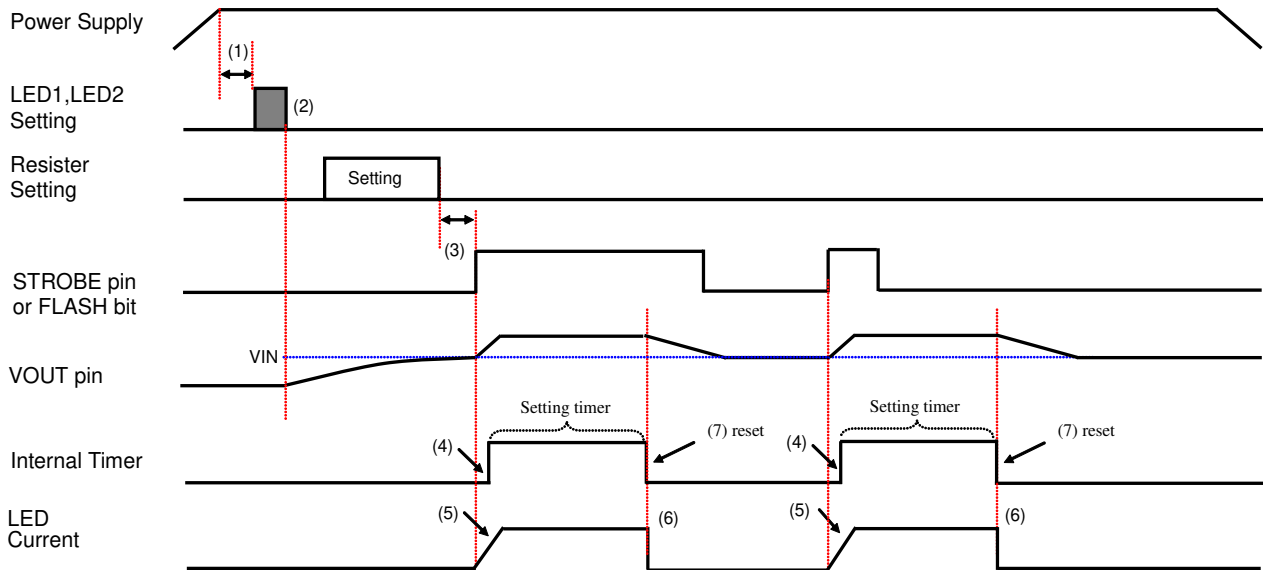

Figure 5. Flashing Sequence (EDGE control)

- (1) To reset the internal circuits of the AP2601, wait 5ms after power is supplied ( $V_{IN} \geq 2.7V$ ) to the AP2601 and set LED2-1 bits = "01", "10" or "11". The AP2601 is powered up by setting LED1 and LED2 bits.
- (2) After LED1 and LED2 bits are set, the VOUT pin voltage changes to  $V_{IN} * 95\%$  within 5ms with inrush current  $< 500mA$ .
- (3) Set STROBE pin= "H" or FLASH bit= "1" after register settings are finished.  
The AP2601 can drive LED by setting the STROBE pin = "H" or FLASH bit = "1" regardless of the VOUT voltage. Wait 5ms and set the STROBE pin = "H" or FLASH bit = "1" after setting LED2-1 bits.
- (4) The internal timer will start after setting the STROBE pin= "L" to "H" or FLASH bit= "0" to "1".
- (5) In the case of  $V_{OUT} = V_{IN}$ , LED current will reach the setting current within 1ms after setting the STROBE pin= "L" to "H" or FLASH bit= "0" to "1".
- (6) After the timer is finished, LED current will change to 0mA immediately even if the STROBE pin= "H" or FLASH bit= "1".
- (7) When the internal timer is finished, it will be reset automatically.

### 3) Torching Sequence (LEVEL Control or EDGE Control)

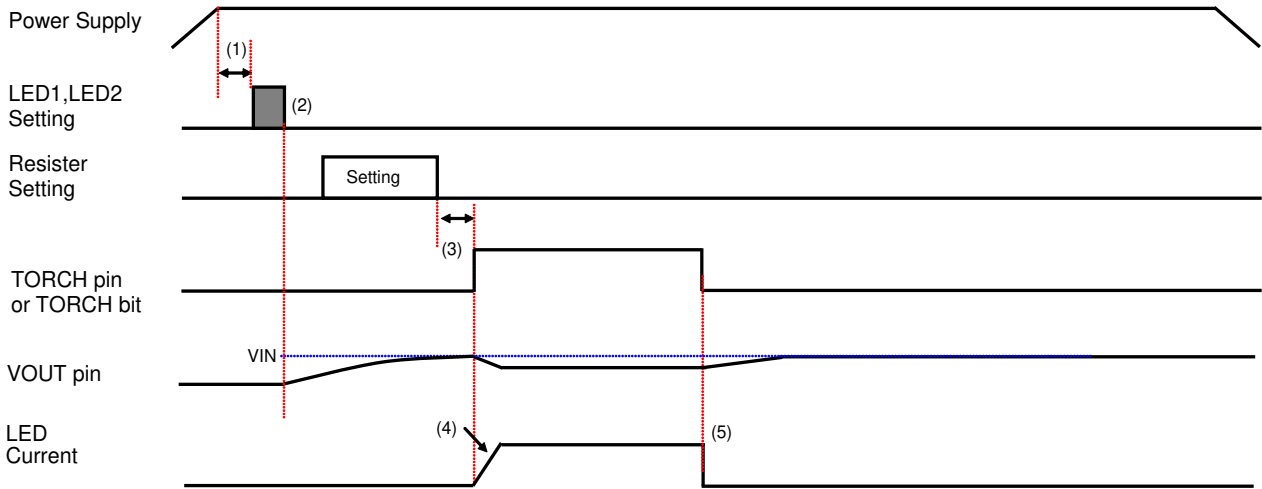

Figure 6. Torching Sequence

- (1) To reset the internal circuits of the AP2601, wait 5ms after power is supplied ( $V_{IN} \geq 2.7V$ ) to the AP2601 and set LED2-1 bits = "01", "10" or "11". The AP2601 is powered up by setting LED1 and LED2 bits.
- (2) After LED1 and LED2 bits are set, the VOUT pin voltage changes to  $V_{IN} \times 95\%$  within 5ms with inrush current  $< 500mA$ .
- (3) Set the TORCH pin = "H" or TORCH bit = "1" after register settings are finished. The AP2601 can drive LED by setting the TORCH pin = "H" or TORCH bit = "1" regardless of the VOUT voltage. Wait 5ms and set the TORCH pin = "H" or TORCH bit = "1" after setting LED2-1 bits.
- (4) In the case of  $V_{OUT} = V_{IN}$ , LED current will reach the setting current within  $300\mu s$  after setting the TORCH pin = "L" to "H" or TORCH bit = "0" to "1".
- (5) LED current will change to 0mA immediately when setting the TORCH pin = "H" to "L" or TORCH bit = "1" to "0".

#### 4) Off → Torch → Flash → Torch → OFF Sequence (LEVEL Control)

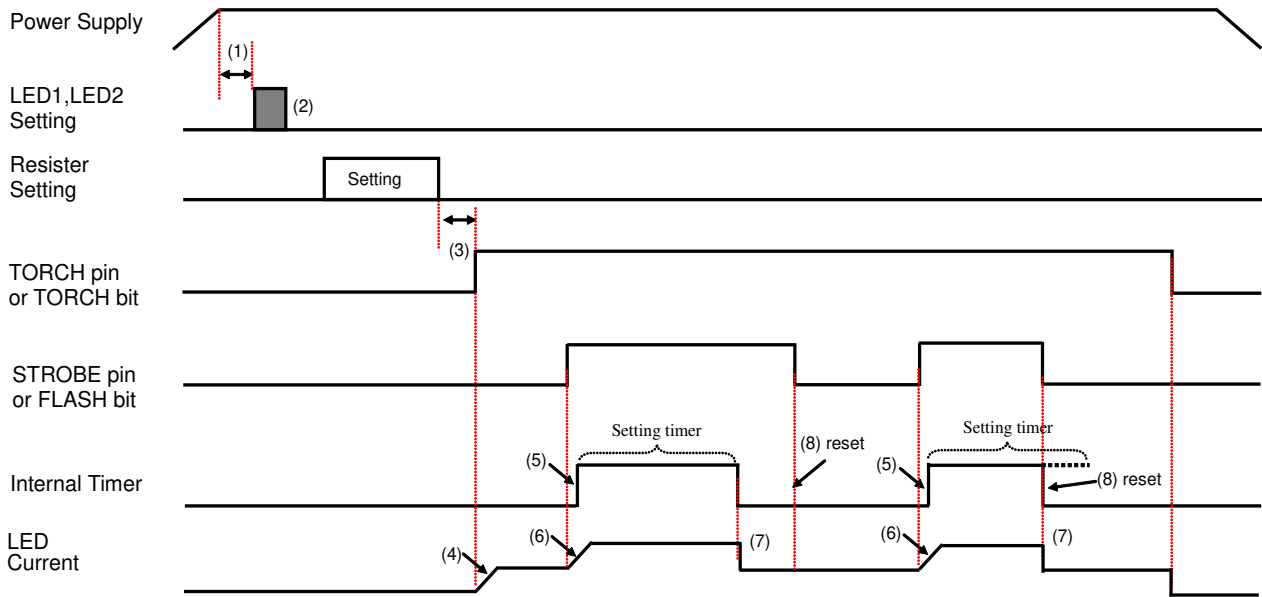

Figure 7. Torching to Flashing Sequence (LEVEL Control)

- (1) To reset the internal circuits of the AP2601, wait 5ms after power is supplied ( $V_{IN} \geq 2.7V$ ) to the AP2601 and set LED2-1 bits = "01", "10" or "11". The AP2601 is powered up by setting LED1 and LED2 bits.
- (2) After LED1 and LED2 bits are set, the VOUT pin voltage changes to  $V_{IN} * 95\%$  within 5ms with inrush current  $< 500mA$ .
- (3) Set TORCH pin= "H" or TORCH bit= "1" after register settings are finished.  
Wait 5ms and set the TORCH pin = "H" or TORCH bit = "1" after setting LED2-1 bits.
- (4) LED current will reach the setting current within  $300\mu s$  after setting the TORCH pin= "L" to "H" or TORCH bit= "0" to "1".
- (5) The internal timer will start after setting the STROBE pin= "L" to "H" or FLASH bit= "0" to "1".
- (6) LED current will reach the setting current within  $500\mu s$  after setting the STROBE pin= "L" to "H" or FLASH bit= "0" to "1".
- (7) When setting the STROBE pin= "H" to "L" or FLASH bit= "1" to "0",  
The time of STROBE= "H" or the time of FLASH bit= "1"  $>$  setting time:  
LED current will change to 0mA immediately after the timer is finished.  
The time of STROBE= "H" or the time of FLASH bit= "1"  $<$  setting time:  
LED current will change to 0mA immediately.
- (8) The timer will be reset by setting the STROBE pin= "H" to "L" or FLASH bit= "1" to "0".



## 5) OFF → Torch → Flash → Torch → OFF (EDGE Control)

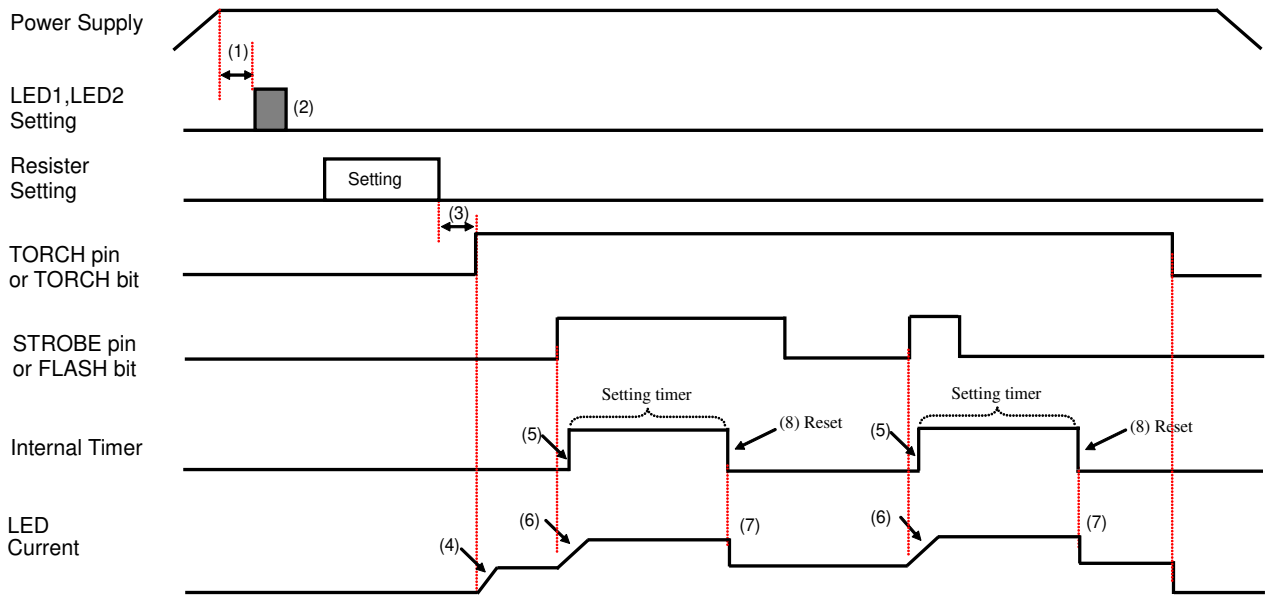

Figure 8. Torching to Flashing Sequence (EDGE Control)

- (1) To reset the internal circuits of the AP2601, wait 5ms after power is supplied ( $V_{IN} \geq 2.7V$ ) to the AP2601 and set LED2-1 bits = "01", "10" or "11". The AP2061 is powered up by setting LED1 and LED2 bits.
- (2) After LED1 and LED2 bits are set, the VOUT pin voltage changes to  $V_{IN} * 95\%$  within 5ms with inrush current  $< 500mA$ .
- (3) Set the TORCH pin = "H" or TORCH bit = "1" after register settings are finished. Wait 5ms and set the TORCH pin = "H" or TORCH bit = "1" after setting LED2-1 bits.
- (4) LED current will reach the setting current within  $300\mu s$  after setting the TORCH pin = "L" to "H" or TORCH bit = "0" to "1".
- (5) The internal timer will start after setting the STROBE pin = "L" to "H" or FLASH bit = "0" to "1".
- (6) LED current will reach the setting current within  $500\mu s$  after setting the STROBE pin = "L" to "H" or FLASH bit = "0" to "1".
- (7) LED current will change to 0mA immediately after the timer is finished even if the STROBE pin = "H" or FLASH bit = "1".
- (8) When the internal timer is finished, it will be reset automatically.

■ Typical Performance Characteristics

(VIN= 3.7V, Ta= 25 °C, with Recommend Parts, using MAMK2520TR47M inductor, unless otherwise specified)

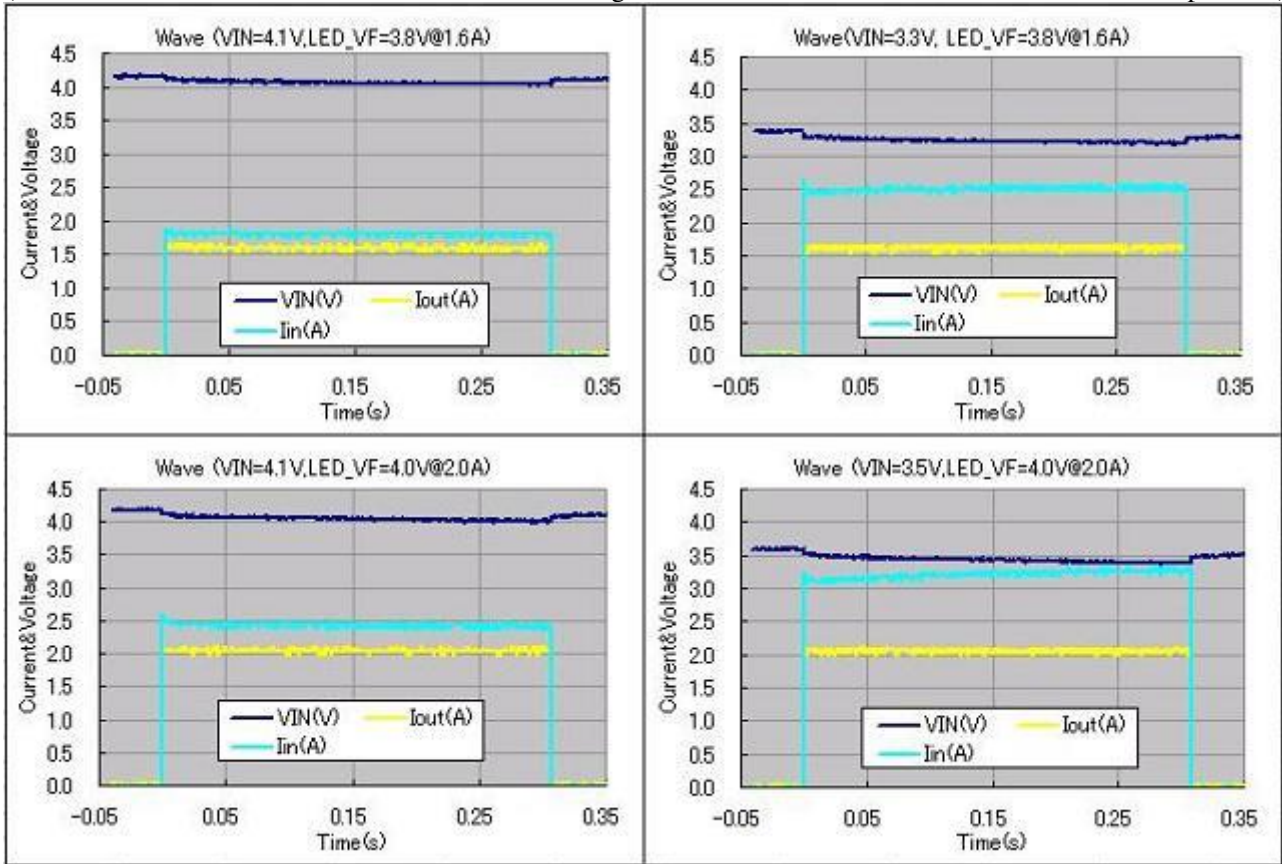

Figure 9. Lighting Characteristics

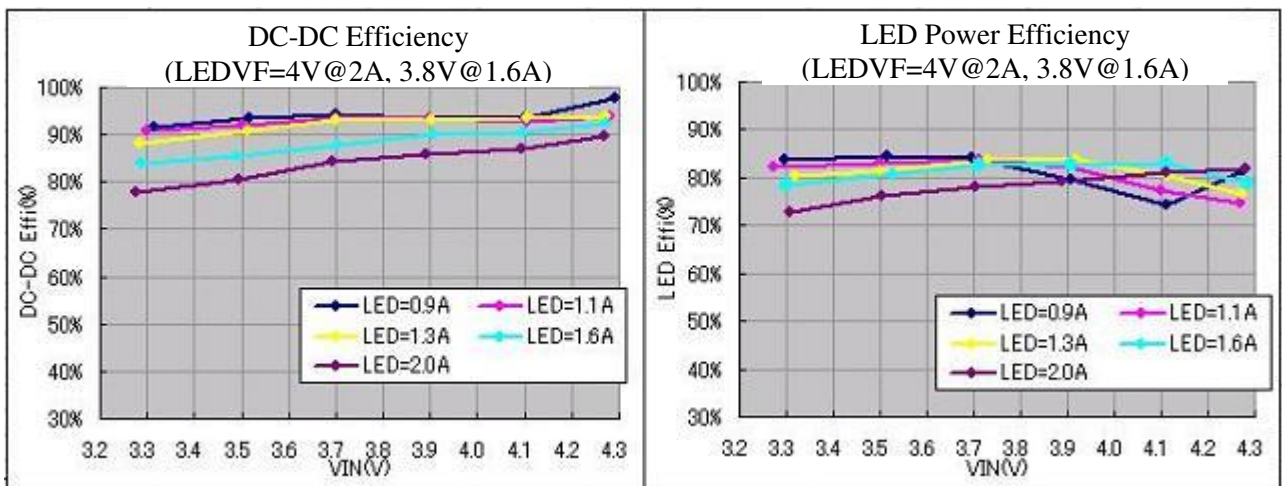

Figure 10. Efficiency Characteristics

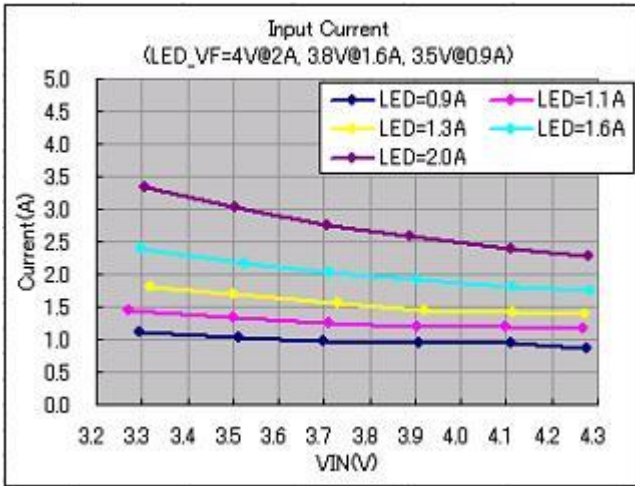

Figure 11. Input Current Characteristics

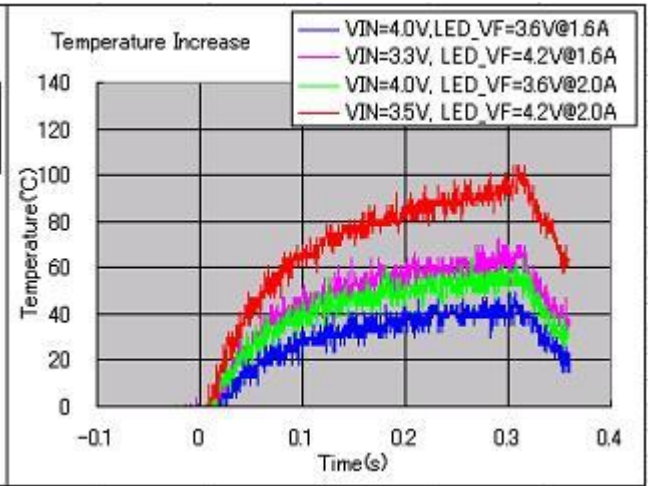

Figure 12. Device Temperature Increase

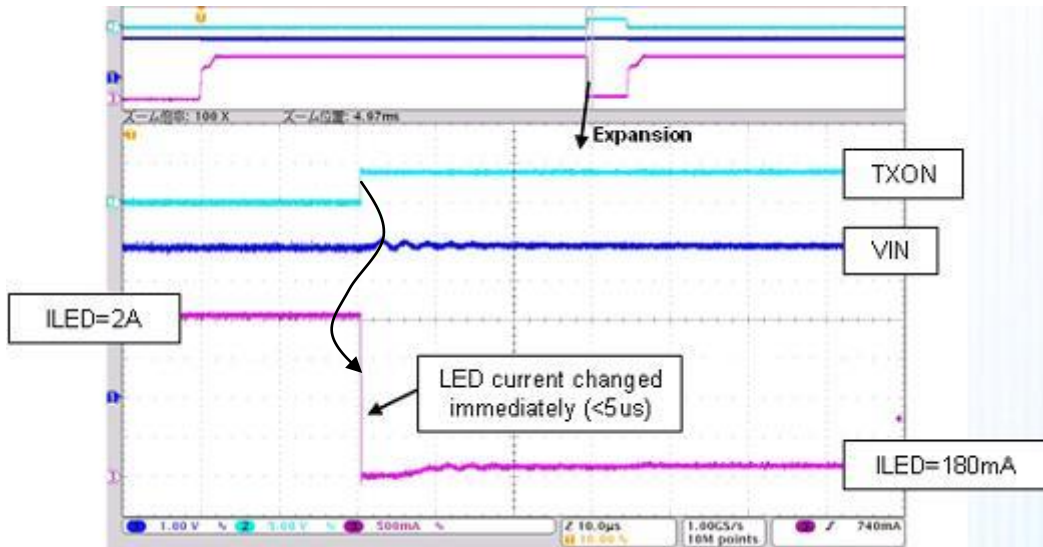

Figure 13. TXON Characteristics (VIN=3.8V, LEDVF=3.8V@2A)

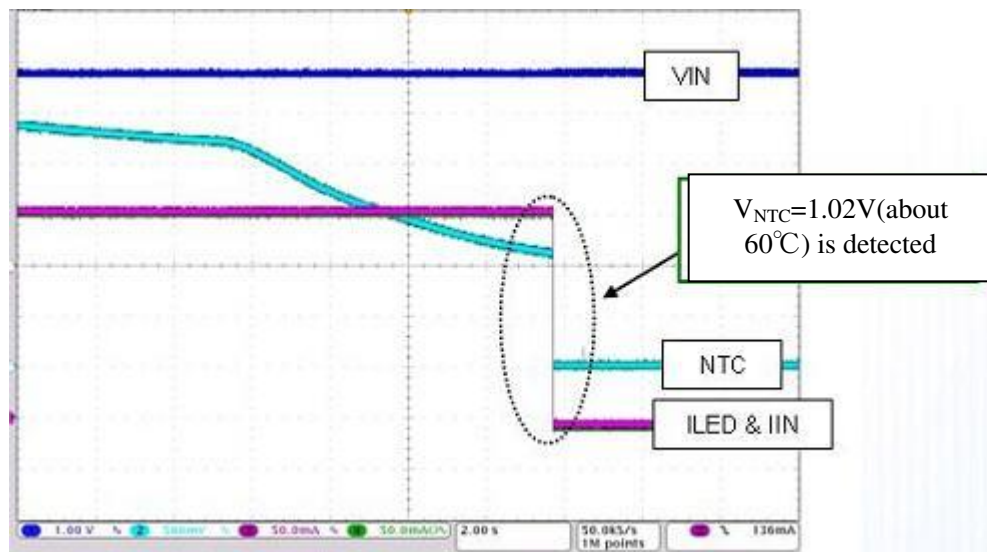

Figure 14. LED Temperature Detection Characteristics (VIN=3.8V)

■ Serial Control Interface

The AP2061 supports a fast-mode I<sup>2</sup>C-bus system (max: 400kHz). Pull-up resistors at the SCL and SDA pins should be connected to VIN pin or less. Refer to the “Recommended Operating Conditions” for the maximum voltage of the VIN pin.

(1) WRITE Operations

Figure 15 shows the data transfer sequence for the I<sup>2</sup>C-bus mode. All commands are preceded by START condition. A HIGH to LOW transition on the SDA line while SCL is HIGH defines START condition (Figure 20). After the START condition, a slave address is sent. This address is 7 bits long followed by the eighth bit that is a data direction bit (R/W). The most significant seven bits of the slave address are fixed as “0110111” (Figure 16). If the slave address matches that of the AP2061, the AP2061 generates an acknowledge and the operation is executed. The master must generate the acknowledge-related clock pulse and release the SDA line (HIGH) during the acknowledge clock pulse (Figure 21). An R/W bit value of “1” indicates that the read operation is to be executed. “0” indicates that the write operation is to be executed.

The second byte consists of the control register address of the AP2061. The format is MSB first, and those most significant 3-bits are fixed to zero (Figure 17). The data after the second byte contains control data. The format is MSB first, 8-bits (Figure 18). The AP2061 generates an acknowledge after each byte is received. A data transfer is always terminated by STOP condition generated by the master. A LOW to HIGH transition on the SDA line while SCL is HIGH defines STOP condition (Figure 20).

The AP2061 can perform more than one byte write operation per sequence. After receipt of the third byte the AP2061 generates an acknowledge and awaits the next data. The master can transmit more than one byte instead of terminating the write cycle after the first data byte is transferred. After receiving each data packet the internal 5-bit address counter is incremented by one, and the next data is automatically taken into the next address. If the address exceeds 0BH prior to generating the stop condition, the address counter will “roll over” to 00H and the previous data will be overwritten.

The data on the SDA line must remain stable during the HIGH period of the clock. The HIGH or LOW state of the data line can only change when the clock signal on the SCL line is LOW (Figure 22) except for the START and STOP conditions.

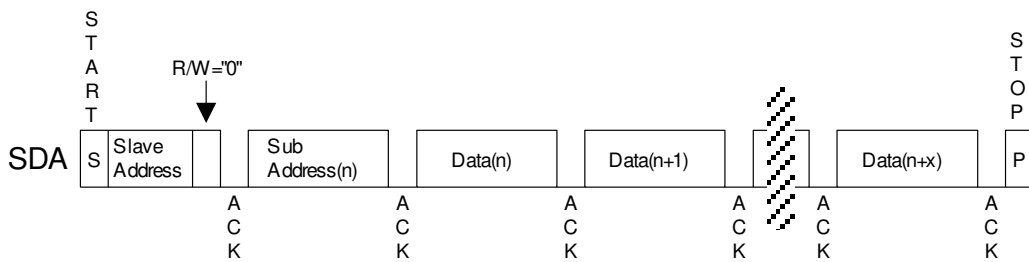

Figure 15. Data Transfer Sequence

0	1	1	0	1	1	1	R/W
---	---	---	---	---	---	---	-----

Figure 16. The First Byte

X	X	X	X	X	A2	A1	A0
---	---	---	---	---	----	----	----

Figure 17. The Second Byte (X: Don't care)

D7	D6	D5	D4	D3	D2	D1	D0
----	----	----	----	----	----	----	----

Figure 18. Byte Structure after The Second Byte

(2) READ Operations

Set the R/W bit = “1” for a READ operation of the AP2061. The master can read the next address’s data by generating an acknowledge instead of terminating the write cycle after the receipt of the first data word. After receiving each data packet the internal 5-bit address counter is incremented, and the next data is automatically taken into the next address. If the address exceeds 06H prior to generating stop condition, the address counter will “roll over” to 00H and the previous data will be overwritten.

The AP2061 supports two basic read operations: RANDOM ADDRESS READ.

(3) RANDOM ADDRESS READ

The random read operation allows the master to access any memory location at random. Prior to issuing the slave address with the R/W bit “1”, the master must first perform a “dummy” write operation. The master issues start request, a slave address (R/W bit = “0”) and then the register address to read. After the register address is acknowledged, the master immediately reissues the start request and the slave address with the R/W bit “1”. The AP2061 then generates an acknowledge, 1 byte of data and increments the internal address counter by 1. If the master does not generate an acknowledge to the data but generates a stop condition, the AP2061 ceases transmission.

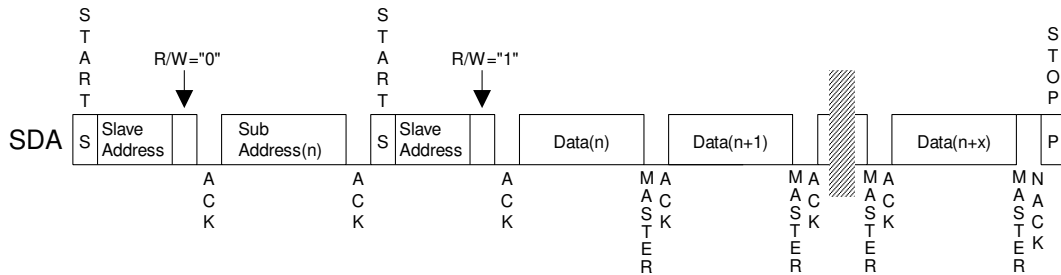

Figure 19. RANDOM ADDRESS READ

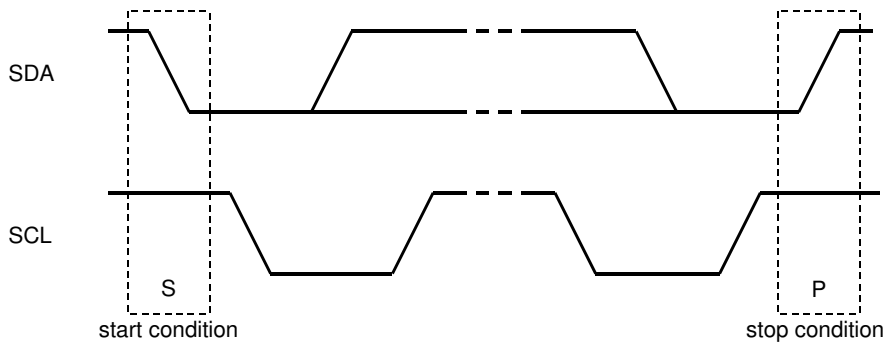

Figure 20. START and STOP Conditions

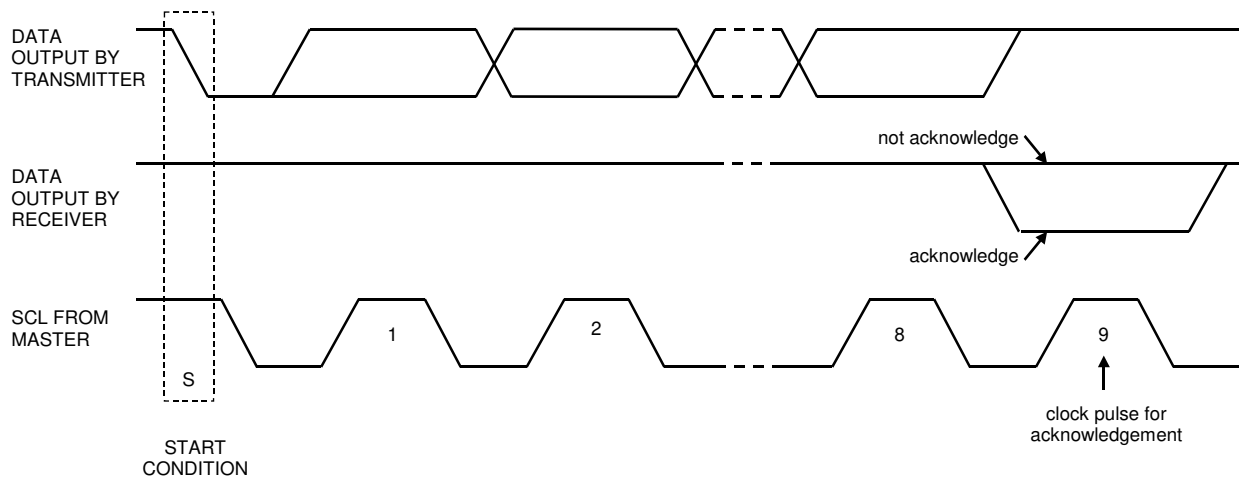

Figure 21. Acknowledge on the I<sup>2</sup>C-Bus

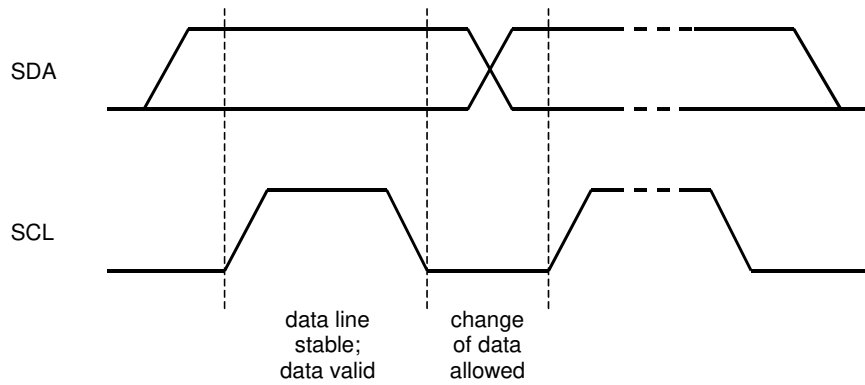

Figure 22. Bit Transfer on the I<sup>2</sup>C-Bus



## 12. Register Map

### ■ Register Map

(PGND= VSS= 0V; (Note 3), VIN= 3.7V, Ta= 25°C, with Recommend Parts, unless otherwise specified)

Address	Register Name	D7	D6	D5	D4	D3	D2	D1	D0
00H	Instruction	INST7	INST6	INST5	INST4	INST3	INST2	INST1	INST0
01H	LED1/2 Control 1							LED2	LED1
02H	LED1/2 Control 2		TSDSEL	CB	EDGE	TIME3	TIME2	TIME1	TIME0
03H	LED1/2 Control 3		DIM	LEDT2	LEDT1	LEDT0	LEDF2	LEDF1	LEDF0
04H	Others		VIN1	VIN0	DET2	DET1	DET0	LIMIT1	LIMIT0
05H	Light Control							FLASH	TORCH
06H	Fault/Status	LIGHTNG	ENNG	TSD	NTC	LO	UVLO	VOS	LS

Note 9. For addresses from 07H, data must not be written.

### ■ Register Definitions

Address	Register Name	D7	D6	D5	D4	D3	D2	D1	D0
00H	Instruction	INST7	INST6	INST5	INST4	INST3	INST2	INST1	INST0
	Read/Write	R/W	R/W	R/W	R/W	R/W	R/W	R/W	R/W
	Default	0	0	0	0	0	0	0	0

INST[7:0]: The instruction for error protection.

If INST[7:0] bits = “01101001” is not written, accessing to the other registers are not valid.

At first, please set INST[7:0] bits = “01101001”.

Address	Register Name	D7	D6	D5	D4	D3	D2	D1	D0
01H	LED1/2 Control							LED2	LED1
	Read/Write	R/W	R/W	R/W	R/W	R/W	R/W	R/W	R/W
	Default	0	0	0	0	0	0	0	0

LED1, LED2: Power ON/OFF of the AP2061 and ON/OFF controlling of LEDs which connect to LED2, LED1.

Table 2. AP2061 & LED Status Setting

LED2	LED1	AP2061 Status
0	0	<b>Power-down</b>
0	1	LED1=on, LED2=off
1	0	LED1= off, LED2=on
1	1	LED1=on, LED2=on

Address	Register Name	D7	D6	D5	D4	D3	D2	D1	D0
02H	LED1/2 Control 2		TSDSEL	CB	EDGE	TIME3	TIME2	TIME1	TIME0
	R/W	R/W	R/W	R/W	R/W	R/W	R/W	R/W	R/W
	Default	0	0	0	0	0	1	1	1

TIME0, TIME1, TIME2, TIME3: The on-time setting for LEDs that connect to LED1, LED2 in flash mode.

Table 3. LED On-time Setting in Flash Mode

TIME3	TIME2	TIME1	TIME0	Time	TIME3	TIME2	TIME1	TIME0	Time
0	0	0	0	5ms	1	0	0	0	120ms
0	0	0	1	10ms	1	0	0	1	150ms
0	0	1	0	20ms	1	0	1	0	200ms
0	0	1	1	30ms	1	0	1	1	250ms
0	1	0	0	40ms	1	1	0	0	300ms
0	1	0	1	50ms	1	1	0	1	400ms
0	1	1	0	70ms	1	1	1	0	600ms
<b>0</b>	<b>1</b>	<b>1</b>	<b>1</b>	<b>90ms</b>	1	1	1	1	800ms

EDGE: Flashing Time Control Method Select

0: Level control

1: Edge control (flashing time is controlled by internal timer)

CB: Current Source Dropping Voltage (VOUT-LED1/2) Setting

0: 0.35V

1: 0.43V

Use this register to set current source dropped voltage (VOUT-LED pins).

When using a LED whose VF is very low, please set CB bit= "1".

(Example: LED current= 2A, LED VF=2.8V @ 2A)

TSDSEL: Thermal Shut Down Recovery Mode

0: Not Recover. Set LED1 bit = LED2 bit = "0" again.

1: Recover Automatically

Address	Register Name	D7	D6	D5	D4	D3	D2	D1	D0
03H	LED1/2 Control 3		DIM	LEDT2	LEDT1	LEDT0	LEDF2	LEDF1	LEDF0
	R/W	R/W	R/W	R/W	R/W	R/W	R/W	R/W	R/W
	Default	0	0	0	0	1	1	0	0

LEDF0, LEDF1, LEDF2: LED Current Setting for LED1 and LED2 channels.

Table 4. LED Current Setting for Flash Mode

LEDF2	LEDF1	LEDF0	FLASH (1ch)	FLASH (total)	Unit
0	0	0	137	274	mA
0	0	1	236	472	mA
0	1	0	337	674	mA
0	1	1	439	878	mA
<b>1</b>	<b>0</b>	<b>0</b>	<b>541</b>	<b>1082</b>	<b>mA</b>
1	0	1	645	1290	mA
1	1	0	800	1600	mA
1	1	1	1000	2000	mA

LEDT0, LEDT1, LEDT2: LED Current Setting for LED1 and LED2 channels.

DIM: Small Torching Current Setting

0: Normal Setting

1: Torching Current = 1/5 Normal Setting Current

Table 5. LED Current Setting for Torch Mode

LEDT2	LEDT1	LEDT0	TORCH (1ch)		TORCH (2ch)		Unit
			DIM= "0"	DIM= "1"	DIM= "0"	DIM= "1"	
0	0	0	25	5.0	50	10	mA
<b>0</b>	<b>0</b>	<b>1</b>	<b>43</b>	<b>8.6</b>	<b>86</b>	<b>17.2</b>	<b>mA</b>
0	1	0	62	12.4	124	24.8	mA
0	1	1	81	16.2	162	32.4	mA
1	0	0	100	20	200	40	mA
1	0	1	120	24	240	48	mA
1	1	0	150	30	300	60	mA
1	1	1	190	38	380	76	mA

Address	Register Name	D7	D6	D5	D4	D3	D2	D1	D0
04H	Others		VIN1	VIN0	DET2	DET1	DET0	LIMIT1	LIMIT0
	R/W	R/W	R/W	R/W	R/W	R/W	R/W	R/W	R/W
	Default	0	0	0	0	0	0	1	0

LIMIT1, LIMIT0: Inductor limit Current Setting

Table 6. Inductor Current Limit Setting

LIMIT1	LIMIT0	Limit Current
<b>0</b>	<b>0</b>	<b>4.4A</b>
0	1	3.5A
1	0	2.5A
1	1	1.5A

DET2, DET1, DET0: NTC pin Voltage Detection Setting (NTC pin= 35 $\mu$ A)

\* Connect a thermistor externally. The AP2061 will power down its all circuits if the NTC pin voltage drops to a level under the value set by these bits as it is regarded that the LEDs are over heated.

When not using this function, set DET[2:0] bits = "000". (The default setting is OFF)

Table 7. NTC pin Voltage Detection

DET2	DET1	DET0	NTC pin Voltage
<b>0</b>	<b>0</b>	<b>0</b>	<b>OFF</b>
0	0	1	0.60V
0	1	0	0.67V
0	1	1	0.74V
1	0	0	0.81V
1	0	1	0.88V
1	1	0	0.95V
1	1	1	1.02V

VIN1, VIN0: Input Voltage Detection

\* By this function, the AP2061 exits Flash mode forcibly if the input voltage is too low. The AP2061 stops flash mode and change to torch mode for a protection if the power supply voltage drops to a level under the value set by these bits. When not using this function, set VIN[1:0] bits = "00". (The default setting is OFF)

Table 8. Battery Voltage Detection

VIN1	VIN0	Detection Voltage
<b>0</b>	<b>0</b>	<b>off</b>
0	1	3.3V
1	0	3.1V
1	1	2.9V

Address	Register Name	D7	D6	D5	D4	D3	D2	D1	D0
05H	Light Control							FLASH	TORCH
	R/W	R/W	R/W	R/W	R/W	R/W	R/W	R/W	R/W
	Default	0	0	0	0	0	0	0	0

FLASH: Drive LED with flashing current

TORCH::Drive LED with torching current

Table 9. LED Control Status (LED1= LED2 bits= “01” or “10” or “11”)

TXON pin	STROBE pin	TORCH pin	FLASH bit	TROCH bit	Status
L	L	L	0	0	Standby
L	L	L	0	1	TORCH
L	L	L	1	0	FLASH
L	L	L	1	1	FLASH
L	L	H	0	0	TORCH
L	L	H	0	1	TORCH
L	L	H	1	0	FLASH
L	L	H	1	1	FLASH
L	H	*	*	*	FLASH
H	L	L	0	0	Standby
H	STROBE pin = “H” or TORCH pin= “H” or FLASH bit = “1” or TORCH bit = “1”				TORCH

Address	Register Name	D7	D6	D5	D4	D3	D2	D1	D0
06H	Fault/Status	LIGHTNG	ENNG	TSD	NTC	LO	UVLO	VOS	LS
	R/W	RD	RD	RD	RD	RD	RD	RD	RD
	Default	0	0	0	0	0	0	0	0

LS: Short Status Bit of the LED1 or LED2 pin

0: Not shorted

1: Shorted to GND

VOS: Short Status Bit of the VOUT1 or VOUT2 pin

0: Not shorted

1: Shorted to GND

UVLO: UVLO Detection

0: Not Detected

1: Detected

LO: LED Open Status Bit

0: Not Open

1: Open

NTC: NTC pin Protection Indication

0: Not working

1: Working

TSD: Thermal Shut Down Detection

0: Not Detected

1: Detected

ENNG: for Start-up Stand-by

0:  $V_{OUT} \geq V_{IN} - 0.1V$  (Stand-by)

1:  $V_{OUT} < V_{IN} - 0.1V$  (Not Stand-by)

LIGHTNG: for Second Start-up Stand-by

0:  $V_{OUT} \approx V_{IN}$  (Stand-by)

1:  $V_{OUT} \neq V_{IN}$  (Not Stand-by)

**13. Recommended External Circuits**

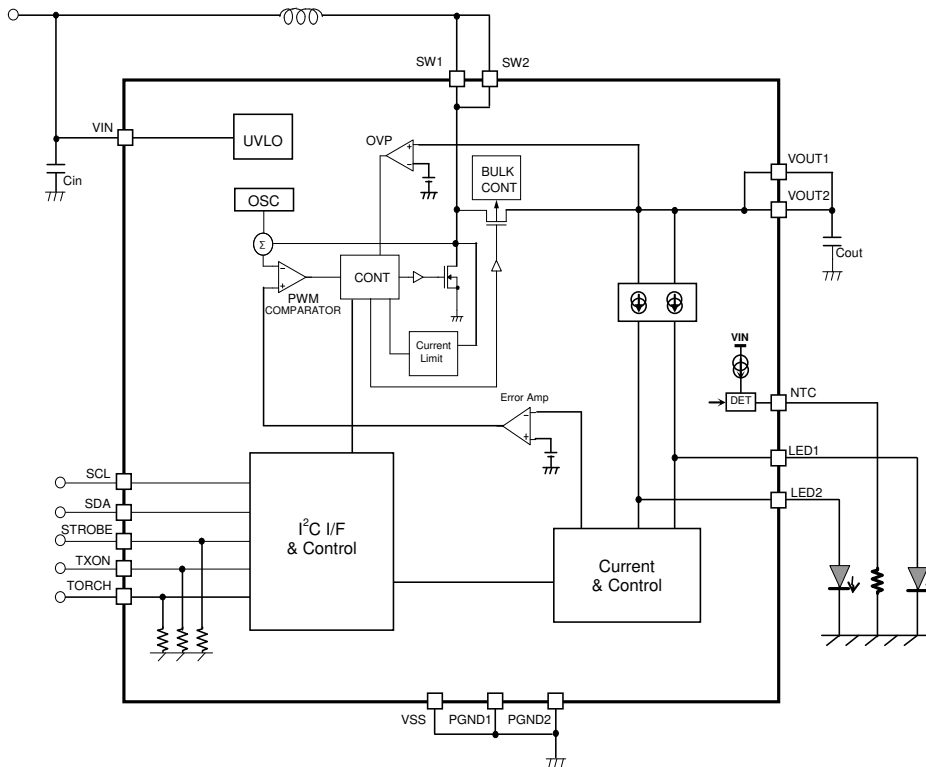

Figure 23. Recommended External Circuits

**Recommended External Parts (LED1=LED2=800mA, VIN = 3.3 to 4.5V, LEDVF≤4.2V)**

Table 10. Recommend External Parts Examples

Item	Symbol	Value	Type (example)	Size (mm)	Manufacturer
Inductor	L	0.47μH	MAMK2520TR47M	2.5 x 2.0 x 1.2	TAIYO-YUDEN
		1μH	DFE252010C (DCR<59Ω)	2.5x2.0x1.2	TOKO
		1μH	LQH44PN1R0NP0 (DCR<50mΩ)	3.7x4.0x1.8	MURATA
		1μH	VLF4014ST-1R0N2R3 (DCR<49mΩ)	3.8x3.6x1.4	TDK
		1μH	TFM252010 (DCR < 65mΩ)	2.5x2.0x1.0	TDK
Capacitor	Cin	4.7μF	GRM188B30J475KE18 (6.3V)	1.6 x 0.8 x 0.8	MURATA
			GRM188B31C475MAAJ (16V)	1.6 x 0.8 x 0.8	
			C1608JB0J475K, C1608JB0J475M	1.6 x 0.8 x 0.8	TDK
			C1608X5R0J475K, C1608X5R0J475M	1.6 x 0.8 x 0.8	TDK
		10μF	GRM219B31C106KA73 (16V)	2.0 x 1.3 x 0.85	MURATA
GRM219R61C106KA73 (16V)	2.0 x 1.3 x 0.85				
GRM188B31A106ME6 (10V)	1.6 x 0.8 x 0.8				
Capacitor	Cout	10μF	C2012JB1A106K085AC (10V), C2012JB0J106K085AB (6.3V)	2.0 x 1.3 x 0.85mm	TDK
			C2012JB1A106K085AC (10V), C2012JB0J106K085AB (6.3V)	2.0 x 1.3 x 0.85	TDK
			GRM219B31C106KA73 (16V)	2.0 x 1.3 x 0.85	MURATA
			GRM219R61C106KA73 (16V)	2.0 x 1.3 x 0.85	
			GRM188B31A106ME6 (10V)	1.6 x 0.8 x 0.8	
NTC Thermistor	NTC	150kΩ	-	1.0x0.5	TDK MURATA
		220kΩ	-		
		470kΩ	-		

Note 10. The PGND and VSS pins must be connected to the same ground plane.

Note 11. The inductor should be placed as close as possible to the AP2061.

Note 12. Capacitors should be placed as close as possible to the AP2061. Low ESR (Equivalent Series Resistance) capacitors are recommended.

Note 13. The wiring connection to LEDs must be less than 20cm.