



Chipsmall Limited consists of a professional team with an average of over 10 year of expertise in the distribution of electronic components. Based in Hongkong, we have already established firm and mutual-benefit business relationships with customers from,Europe,America and south Asia,supplying obsolete and hard-to-find components to meet their specific needs.

With the principle of “Quality Parts,Customers Priority,Honest Operation,and Considerate Service”,our business mainly focus on the distribution of electronic components. Line cards we deal with include Microchip,ALPS,ROHM,Xilinx,Pulse,ON,Everlight and Freescale. Main products comprise IC,Modules,Potentiometer,IC Socket,Relay,Connector.Our parts cover such applications as commercial,industrial, and automotives areas.

We are looking forward to setting up business relationship with you and hope to provide you with the best service and solution. Let us make a better world for our industry!



Contact us

Tel: +86-755-8981 8866 Fax: +86-755-8427 6832

Email & Skype: info@chipsmall.com Web: www.chipsmall.com

Address: A1208, Overseas Decoration Building, #122 Zhenhua RD., Futian, Shenzhen, China



600mA CMOS LDO REGULATOR WITH ENABLE

AP2112

General Description

The AP2112 is CMOS process low dropout linear regulator with enable function, the regulator delivers a guaranteed 600mA (min.) continuous load current.

The AP2112 provides 1.2V, 1.8V, 2.5V, 2.6V, 2.8V and 3.3V regulated output and 0.8V to 5V adjustable output, and provides excellent output accuracy $\pm 1.5\%$, also provides an excellent load regulation, line regulation and excellent load transient performance due to very fast loop response. The AP2112 has built-in auto discharge function.

The regulator features low power consumption, and provides SOT-23-5, SOT-89-5, and SOIC-8 packages.

Features

- Output Voltage Accuracy: $\pm 1.5\%$
- Output Current: 600mA (Min.)
- Foldback Short Current Protection: 50mA
- Enable Function to Turn ON/OFF V_{OUT}
- Low Dropout Voltage (3.3V): 250mV (Typ.) @ $I_{OUT}=600mA$
- Excellent Load Regulation: 0.2%/A (Typ.)
- Excellent Line Regulation: 0.02%/V (Typ.)
- Low Quiescent Current: 55 μA (Typ.)
- Low Standby Current: 0.01 μA (Typ.)
- Low Output Noise: 50 μV_{RMS}
- PSRR: 100Hz -65dB, 1kHz -65dB
- OTSD Protection
- Stable with 1.0 μF Flexible Cap: Ceramic, Tantalum and Aluminum Electrolytic
- Operation Temperature Range: -40°C to 85°C
- ESD: MM 400V, HBM 4000V

Applications

- Laptop Computer
- Portable DVD
- LCD Monitor

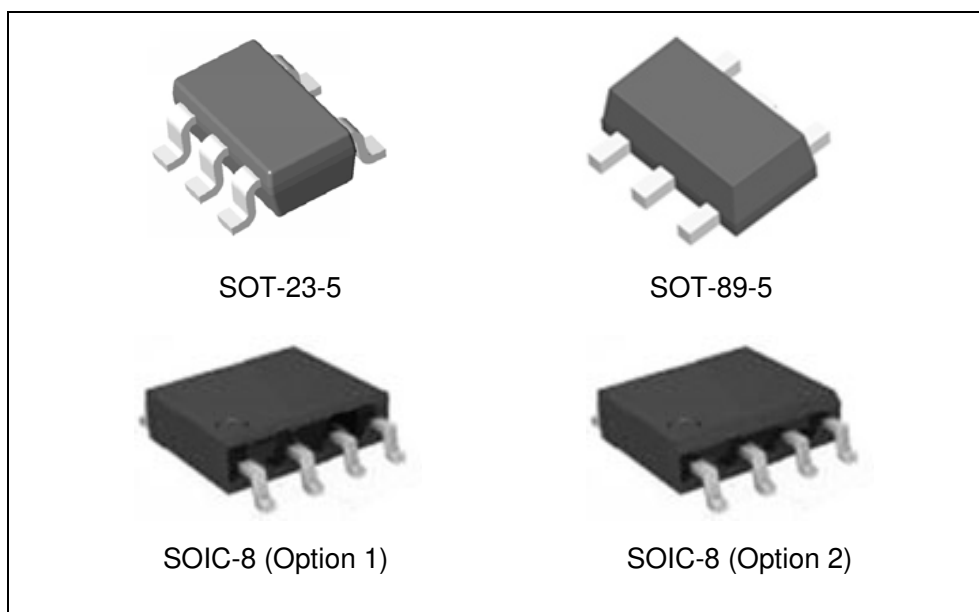

Figure 1. Package Types of AP2112

600mA CMOS LDO REGULATOR WITH ENABLE
AP2112
Pin Configuration

Figure 2. Pin Configuration of AP2112 (Top View)

Pin Descriptions

PIN No.			Name	Descriptions
SOT-23-5	SOT-89-5	SOIC-8		
1	4	8	VIN	Input Voltage
2	2	6, 7	GND	GND
3	3 (R5) 1 (R5A)	5	EN	Chip Enable, H – normal work, L – shutdown output
4			ADJ/NC	Adjust Output for ADJ version/No Connection for Fixed Version
	1 (R5) 3 (R5A)	2, 3, 4	NC	No Connection
5	5	1	VOUT	Output Voltage

600mA CMOS LDO REGULATOR WITH ENABLE
AP2112
Functional Block Diagram

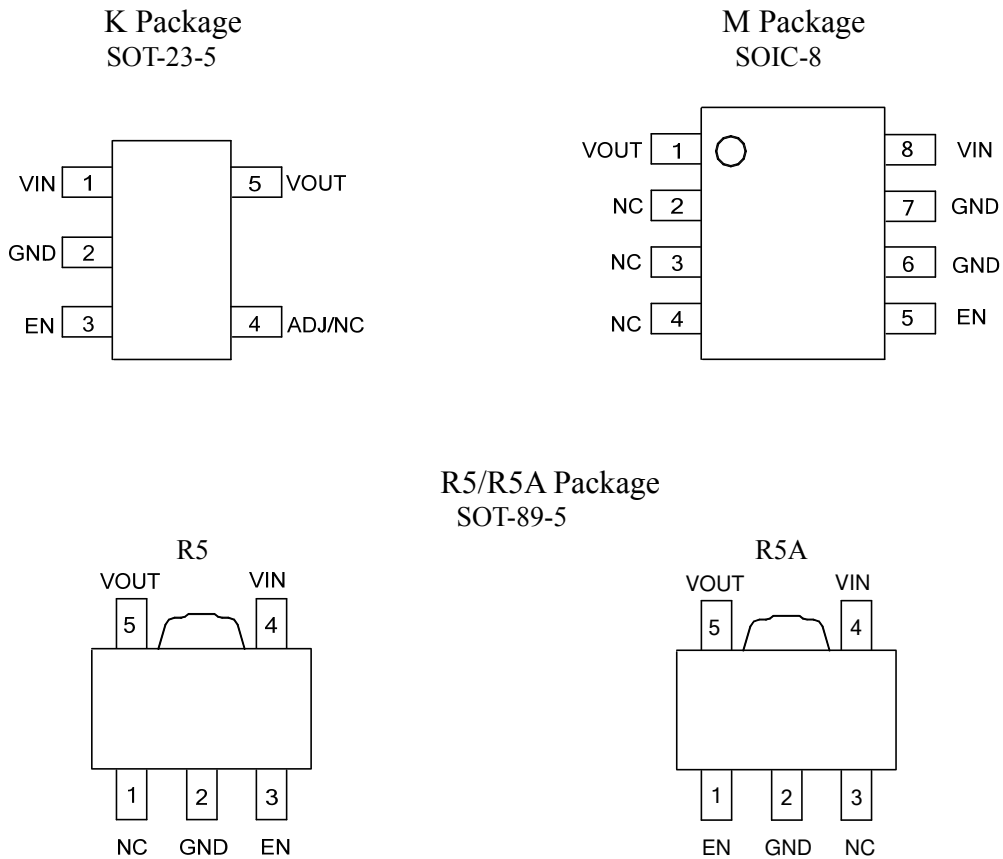
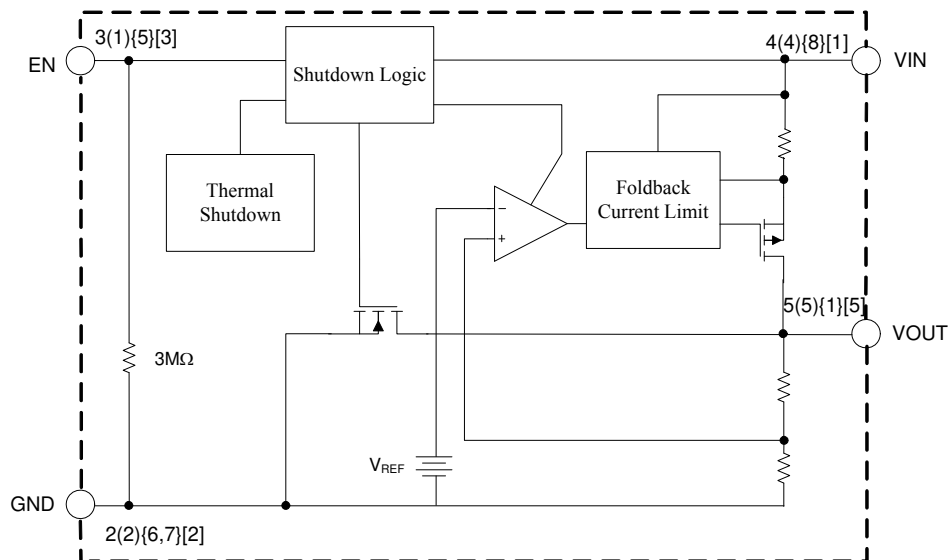
A (B){C}[D]
 A: SOT-89-5 (R5)
 B: SOT-89-5 (R5A)
 C: SOIC-8
 D: SOT-23-5

Figure 3. Functional Block Diagram of AP2112 for Fixed Version

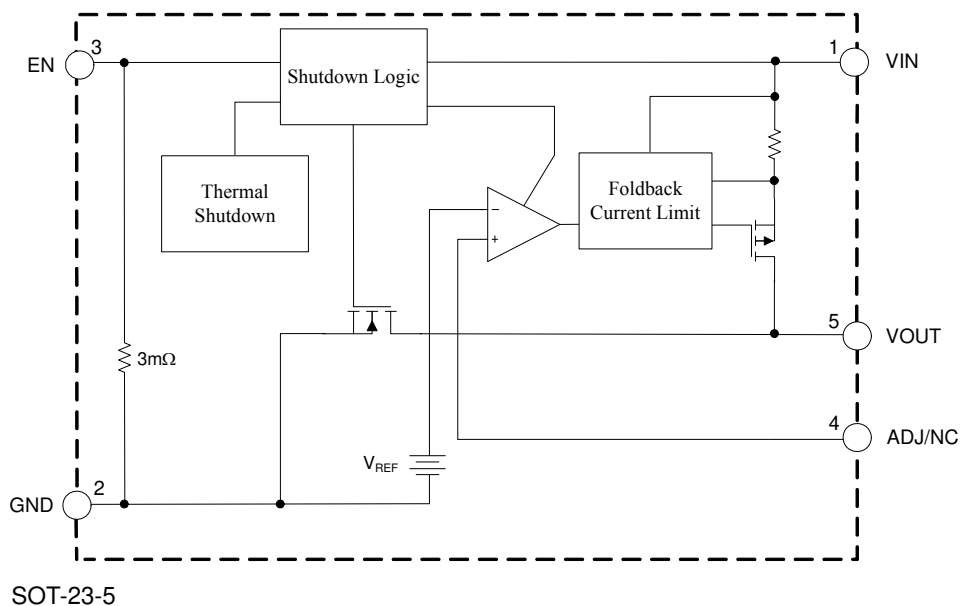
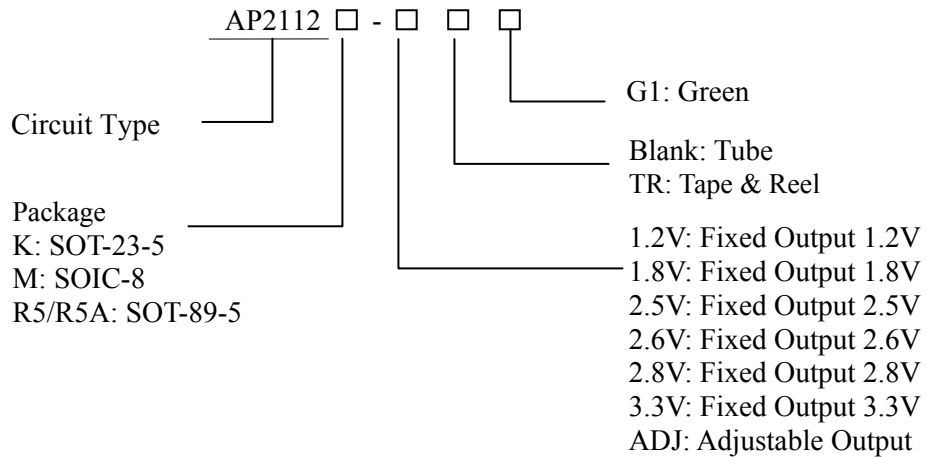

Figure 4. Functional Block Diagram of AP2112 for Adjustable Version

600mA CMOS LDO REGULATOR WITH ENABLE

AP2112

Ordering Information



Package	Temperature Range	Condition	Part Number	Marking ID	Packing Type
SOT-23-5	-40 to 85°C	1.2V	AP2112K-1.2TRG1	G3L	Tape & Reel
		1.8V	AP2112K-1.8TRG1	G3M	Tape & Reel
		2.5V	AP2112K-2.5TRG1	G3N	Tape & Reel
		2.6V	AP2112K-2.6TRG1	G5N	Tape & Reel
		2.8V	AP2112K-2.8TRG1	G3Q	Tape & Reel
		3.3V	AP2112K-3.3TRG1	G3P	Tape & Reel
		ADJ	AP2112K-ADJTRG1	G3T	Tape & Reel
SOIC-8	-40 to 85°C	1.2V	AP2112M-1.2G1	2112M-1.2G1	Tube
			AP2112M-1.2TRG1	2112M-1.2G1	Tape & Reel
		1.8V	AP2112M-1.8G1	2112M-1.8G1	Tube
			AP2112M-1.8TRG1	2112M-1.8G1	Tape & Reel
		2.5V	AP2112M-2.5G1	2112M-2.5G1	Tube
			AP2112M-2.5TRG1	2112M-2.5G1	Tape & Reel
		2.6V	AP2112M-2.6G1	2112M-2.6G1	Tube
			AP2112M-2.6TRG1	2112M-2.6G1	Tape & Reel
3.3V	AP2112M-3.3G1	2112M-3.3G1	Tube		
	AP2112M-3.3TRG1	2112M-3.3G1	Tape & Reel		
SOT-89-5	-40 to 85°C	1.2V(R5)	AP2112R5-1.2TRG1	G37D	Tape & Reel
		1.8V(R5)	AP2112R5-1.8TRG1	G37E	Tape & Reel
		2.5V(R5)	AP2112R5-2.5TRG1	G37F	Tape & Reel
		2.6V(R5)	AP2112R5-2.6TRG1	G13F	Tape & Reel
		3.3V(R5)	AP2112R5-3.3TRG1	G37G	Tape & Reel
SOT-89-5	-40 to 85°C	1.2V(R5A)	AP2112R5A-1.2TRG1	G33C	Tape & Reel
		1.8V(R5A)	AP2112R5A-1.8TRG1	G33E	Tape & Reel
		2.5V(R5A)	AP2112R5A-2.5TRG1	G28G	Tape & Reel
		2.6V(R5A)	AP2112R5A-2.6TRG1	G13E	Tape & Reel
		3.3V(R5A)	AP2112R5A-3.3TRG1	G28H	Tape & Reel

BCD Semiconductor's Pb-free products, as designated with "G1" suffix in the part number, are RoHS compliant and Green.

**600mA CMOS LDO REGULATOR WITH ENABLE****AP2112****Absolute Maximum Ratings (Note 1)**

Parameter	Symbol	Value		Unit
Power Supply Voltage	V_{CC}	6.5		V
Operating Junction Temperature Range	T_J	150		°C
Storage temperature Range	T_{STG}	-65 to 150		°C
Lead Temperature (Soldering, 10 Seconds)	T_{LEAD}	260		°C
Thermal Resistance (Junction to Ambient)(No Heatsink)	θ_{JA}	SOT-23-5	184	°C/W
		SOIC-8	114	
		SOT-89-5	120	
ESD (Machine Model)		400		V
ESD (Human Body Model)		4000		V

Note 1: Stresses greater than those listed under “Absolute Maximum Ratings” may cause permanent damage to the device. These are stress ratings only, and functional operation of the device at these or any other conditions beyond those indicated under “Recommended Operating Conditions” is not implied. Exposure to “Absolute Maximum Ratings” for extended periods may affect device reliability.

Recommended Operating Conditions

Parameter	Symbol	Min	Max	Unit
Supply Voltage	V_{IN}	2.5	6.0	V
Ambient Operation Temperature Range	T_A	-40	85	°C



600mA CMOS LDO REGULATOR WITH ENABLE

AP2112

Electrical Characteristics

AP2112-1.2 Electrical Characteristic (Note 2)

$V_{IN}=2.5V$, $C_{IN}=1.0\mu F$ (Ceramic), $C_{OUT}=1.0\mu F$ (Ceramic), Typical $T_A=25^\circ C$, unless otherwise specified (Note 3).

Parameter	Symbol	Test Conditions	Min	Typ	Max	Unit
Output Voltage	V_{OUT}	$V_{IN}=2.5V$, $1mA \leq I_{OUT} \leq 30mA$	$V_{OUT} * 98.5\%$	1.2	$V_{OUT} * 101.5\%$	V
Maximum Output Current	$I_{OUT(MAX)}$	$V_{IN}=2.5V$, $V_{OUT}=1.182V$ to $1.218V$	600			mA
Load Regulation	$(\Delta V_{OUT}/V_{OUT}) / \Delta I_{OUT}$	$V_{IN}=2.5V$, $1mA \leq I_{OUT} \leq 600mA$	-1	0.2	1	%/A
Line Regulation	$(\Delta V_{OUT}/V_{OUT}) / \Delta V_{IN}$	$2.5V \leq V_{IN} \leq 6V$, $I_{OUT}=30mA$	-0.1	0.02	0.1	%/V
Dropout Voltage	V_{DROP}	$I_{OUT}=10mA$		1000	1300	mV
		$I_{OUT}=300mA$		1000	1300	
		$I_{OUT}=600mA$		1000	1300	
Quiescent Current	I_Q	$V_{IN}=2.5V$, $I_{OUT}=0mA$		55	80	μA
Standby Current	I_{STD}	$V_{IN}=2.5V$, V_{EN} in OFF mode		0.01	1.0	μA
Power Supply Rejection Ratio	PSRR	Ripple 0.5Vp-p $V_{IN}=2.5V$, $I_{OUT}=100mA$	$f=100Hz$		65	dB
			$f=1KHz$		65	
Output Voltage Temperature Coefficient	$(\Delta V_{OUT}/V_{OUT}) / \Delta T$	$I_{OUT}=30mA$ $T_A = -40^\circ C$ to $85^\circ C$		± 100		ppm/ $^\circ C$
Short Current Limit	I_{SHORT}	$V_{OUT}=0V$		50		mA
RMS Output Noise	V_{NOISE}	No Load, $10Hz \leq f \leq 100kHz$		50		μV_{RMS}
V_{EN} High Voltage	V_{IH}	Enable logic high, regulator on	1.5		6.0	V
V_{EN} Low Voltage	V_{IL}	Enable logic low, regulator off	0		0.4	
Start-up Time	t_S	No Load		20		μs
EN Pull Down Resistor	R_{PD}			3.0		$M\Omega$
V_{OUT} Discharge Resistor	R_{DCHG}	Set EN pin at Low		60		Ω
Thermal Shutdown Temperature	T_{OTSD}			160		$^\circ C$
Thermal Shutdown Hysteresis	T_{HYOTSD}			25		
Thermal Resistance	θ_{JC}	SOT-23-5		96		$^\circ C/W$
		SOIC-8		75		
		SOT-89-5		47		

Note 2: To prevent the Short Circuit Current protection feature from being prematurely activated, the input voltage must be applied before a current source load is applied.

Note 3: Production testing at $T_A=25^\circ C$. Over temperature specifications guaranteed by design only.



600mA CMOS LDO REGULATOR WITH ENABLE

AP2112

Electrical Characteristics (Continued)

AP2112-1.8 Electrical Characteristic (Note 2)

V_{IN}=2.8V, C_{IN}=1.0μF (Ceramic), C_{OUT}=1.0μF (Ceramic), Typical T_A=25°C, unless otherwise specified (Note 3).

Parameter	Symbol	Test Conditions	Min	Typ	Max	Unit
Output Voltage	V _{OUT}	V _{IN} =2.8V, 1mA≤I _{OUT} ≤30mA	V _{OUT} *98.5%	1.8	V _{OUT} *101.5%	V
Maximum Output Current	I _{OUT(MAX)}	V _{IN} =2.8V, V _{OUT} =1.773V to 1.827V	600			mA
Load Regulation	(ΔV _{OUT} /V _{OUT})/ ΔI _{OUT}	V _{OUT} =1.8V, V _{IN} =V _{OUT} +1V, 1mA≤I _{OUT} ≤600mA	-1	0.2	1	%/A
Line Regulation	(ΔV _{OUT} /V _{OUT})/ ΔV _{IN}	2.8V≤V _{IN} ≤6V, I _{OUT} =30mA	-0.1	0.02	0.1	%/V
Dropout Voltage	V _{DROP}	I _{OUT} =10mA		500	700	mV
		I _{OUT} =300mA		500	700	
		I _{OUT} =600mA		500	700	
Quiescent Current	I _Q	V _{IN} =2.8V, I _{OUT} =0mA		55	80	μA
Standby Current	I _{STD}	V _{IN} =2.8V, V _{EN} in OFF mode		0.01	1.0	μA
Power Supply Rejection Ratio	PSRR	Ripple 0.5Vp-p V _{IN} =2.8V, I _{OUT} =100mA	f=100Hz		65	dB
			f=1KHz		65	
Output Voltage Temperature Coefficient	(ΔV _{OUT} /V _{OUT})/ ΔT	I _{OUT} =30mA T _A =-40°C to 85°C		±100		ppm/°C
Short Current Limit	I _{SHORT}	V _{OUT} =0V		50		mA
RMS Output Noise	V _{NOISE}	No Load, 10Hz≤f≤100kHz		50		μV _{RMS}
V _{EN} High Voltage	V _{IH}	Enable logic high, regulator on	1.5		6.0	V
V _{EN} Low Voltage	V _{IL}	Enable logic low, regulator off	0		0.4	
Start-up Time	t _S	No Load		20		μs
EN Pull Down Resistor	R _{PD}			3.0		MΩ
V _{OUT} Discharge Resistor	R _{DCHG}	Set EN pin at Low		60		Ω
Thermal Shutdown Temperature	T _{OTSD}			160		°C
Thermal Shutdown Hysteresis	T _{HYOTSD}			25		
Thermal Resistance	θ _{JC}	SOT-23-5		96		°C/W
		SOIC-8		75		
		SOT-89-5		47		

Note 2: To prevent the Short Circuit Current protection feature from being prematurely activated, the input voltage must be applied before a current source load is applied.

Note 3: Production testing at T_A=25°C. Over temperature specifications guaranteed by design only.



600mA CMOS LDO REGULATOR WITH ENABLE

AP2112

Electrical Characteristics (Continued)

AP2112-2.5 Electrical Characteristic (Note 2)

V_{IN}=3.5V, C_{IN}=1.0μF (Ceramic), C_{OUT}=1.0μF (Ceramic), Typical T_A=25°C, unless otherwise specified (Note 3).

Parameter	Symbol	Test Conditions	Min	Typ	Max	Unit
Output Voltage	V _{OUT}	V _{IN} =3.5V, 1mA≤I _{OUT} ≤30mA	V _{OUT} *98.5%	2.5	V _{OUT} *101.5%	V
Maximum Output Current	I _{OUT(MAX)}	V _{IN} =3.5V, V _{OUT} =2.463V to 2.537V	600			mA
Load Regulation	(ΔV _{OUT} /V _{OUT})/ ΔI _{OUT}	V _{OUT} =2.5V, V _{IN} =V _{OUT} +1V, 1mA≤I _{OUT} ≤600mA	-1	0.2	1	%/A
Line Regulation	(ΔV _{OUT} /V _{OUT})/ ΔV _{IN}	3.5V≤V _{IN} ≤6V, I _{OUT} =30mA	-0.1	0.02	0.1	%/V
Dropout Voltage	V _{DROP}	I _{OUT} =10mA		5	8	mV
		I _{OUT} =300mA		125	200	
		I _{OUT} =600mA		250	400	
Quiescent Current	I _Q	V _{IN} =3.5V, I _{OUT} =0mA		55	80	μA
Standby Current	I _{STD}	V _{IN} =3.5V, V _{EN} in OFF mode		0.01	1.0	μA
Power Supply Rejection Ratio	PSRR	Ripple 0.5Vp-p V _{IN} =3.5V, I _{OUT} =100mA	f=100Hz		65	dB
			f=1KHz		65	
Output Voltage Temperature Coefficient	(ΔV _{OUT} /V _{OUT})/ ΔT	I _{OUT} =30mA T _A =-40°C to 85°C		±100		ppm/°C
Short Current Limit	I _{SHORT}	V _{OUT} =0V		50		mA
RMS Output Noise	V _{NOISE}	No Load, 10Hz≤f≤100kHz		50		μV _{RMS}
V _{EN} High Voltage	V _{IH}	Enable logic high, regulator on	1.5		6.0	V
V _{EN} Low Voltage	V _{IL}	Enable logic low, regulator off	0		0.4	
Start-up Time	t _S	No Load		20		μs
EN Pull Down Resistor	R _{PD}			3.0		MΩ
V _{OUT} Discharge Resistor	R _{DCHG}	Set EN pin at Low		60		Ω
Thermal Shutdown Temperature	T _{OTSD}			160		°C
Thermal Shutdown Hysteresis	T _{HYOTSD}			25		
Thermal Resistance	θ _{JC}	SOT-23-5		96		°C/W
		SOIC-8		75		
		SOT-89-5		47		

Note 2: To prevent the Short Circuit Current protection feature from being prematurely activated, the input voltage must be applied before a current source load is applied.

Note 3: Production testing at T_A=25°C. Over temperature specifications guaranteed by design only.



600mA CMOS LDO REGULATOR WITH ENABLE

AP2112

Electrical Characteristics (Continued)

AP2112-2.6 Electrical Characteristic (Note 2)

$V_{IN}=3.6V$, $C_{IN}=1.0\mu F$ (Ceramic), $C_{OUT}=1.0\mu F$ (Ceramic), Typical $T_A=25^\circ C$, unless otherwise specified (Note 3).

Parameter	Symbol	Test Conditions	Min	Typ	Max	Unit
Output Voltage	V_{OUT}	$V_{IN}=3.6V$, $1mA \leq I_{OUT} \leq 30mA$	$V_{OUT} * 98.5\%$	2.6	$V_{OUT} * 101.5\%$	V
Maximum Output Current	$I_{OUT(MAX)}$	$V_{IN}=3.6V$, $V_{OUT}=2.561V$ to $2.639V$	600			mA
Load Regulation	$\frac{\Delta V_{OUT}/V_{OUT}}{\Delta I_{OUT}}$	$V_{OUT}=2.6V$, $V_{IN}=V_{OUT}+1V$, $1mA \leq I_{OUT} \leq 600mA$	-1	0.2	1	%/A
Line Regulation	$\frac{(\Delta V_{OUT}/V_{OUT})}{\Delta V_{IN}}$	$3.6V \leq V_{IN} \leq 6V$, $I_{OUT}=30mA$	-0.1	0.02	0.1	%/V
Dropout Voltage	V_{DROP}	$I_{OUT}=10mA$		5	8	mV
		$I_{OUT}=300mA$		125	200	
		$I_{OUT}=600mA$		250	400	
Quiescent Current	I_Q	$V_{IN}=3.6V$, $I_{OUT}=0mA$		55	80	μA
Standby Current	I_{STD}	$V_{IN}=3.6V$, V_{EN} in OFF mode		0.01	1.0	μA
Power Supply Rejection Ratio	PSRR	Ripple 0.5Vp-p $V_{IN}=3.6V$, $I_{OUT}=100mA$	$f=100Hz$		65	dB
			$f=1KHz$		65	
Output Voltage Temperature Coefficient	$(\Delta V_{OUT}/V_{OUT}) / \Delta T$	$I_{OUT}=30mA$ $T_A=-40^\circ C$ to $85^\circ C$		± 100		ppm/ $^\circ C$
Short Current Limit	I_{SHORT}	$V_{OUT}=0V$		50		mA
RMS Output Noise	V_{NOISE}	No Load, $10Hz \leq f \leq 100kHz$		50		μV_{RMS}
V_{EN} High Voltage	V_{IH}	Enable logic high, regulator on	1.5		6.0	V
V_{EN} Low Voltage	V_{IL}	Enable logic low, regulator off	0		0.4	
Start-up Time	t_s	No Load		20		μs
EN Pull Down Resistor	R_{PD}			3.0		$M\Omega$
V_{OUT} Discharge Resistor	R_{DCHG}	Set EN pin at Low		60		Ω
Thermal Shutdown Temperature	T_{OTSD}			160		$^\circ C$
Thermal Shutdown Hysteresis	T_{HYOTSD}			25		
Thermal Resistance	θ_{JC}	SOT-23-5		96		$^\circ C/W$
		SOIC-8		75		
		SOT-89-5		47		

Note 2: To prevent the Short Circuit Current protection feature from being prematurely activated, the input voltage must be applied before a current source load is applied.

Note 3: Production testing at $T_A=25^\circ C$. Over temperature specifications guaranteed by design only.



600mA CMOS LDO REGULATOR WITH ENABLE

AP2112

Electrical Characteristics (Continued)

AP2112-2.8 Electrical Characteristic (Note 2)

$V_{IN}=3.8V$, $C_{IN}=1.0\mu F$ (Ceramic), $C_{OUT}=1.0\mu F$ (Ceramic), Typical $T_A=25^\circ C$, unless otherwise specified (Note 3).

Parameter	Symbol	Test Conditions	Min	Typ	Max	Unit
Output Voltage	V_{OUT}	$V_{IN}=3.8V$, $1mA \leq I_{OUT} \leq 30mA$	$V_{OUT} * 98.5\%$	2.8	$V_{OUT} * 101.5\%$	V
Maximum Output Current	$I_{OUT(MAX)}$	$V_{IN}=3.8V$, $V_{OUT}=2.758V$ to $2.842V$	600			mA
Load Regulation	$(\Delta V_{OUT}/V_{OUT}) / \Delta I_{OUT}$	$V_{OUT}=2.8V$, $V_{IN}=V_{OUT}+1V$, $1mA \leq I_{OUT} \leq 600mA$	-1	0.2	1	%/A
Line Regulation	$(\Delta V_{OUT}/V_{OUT}) / \Delta V_{IN}$	$3.8V \leq V_{IN} \leq 6V$, $I_{OUT}=30mA$	-0.1	0.02	0.1	%/V
Dropout Voltage	V_{DROP}	$I_{OUT}=10mA$		5	8	mV
		$I_{OUT}=300mA$		125	200	
		$I_{OUT}=600mA$		250	400	
Quiescent Current	I_Q	$V_{IN}=3.8V$, $I_{OUT}=0mA$		55	80	μA
Standby Current	I_{STD}	$V_{IN}=3.8V$, V_{EN} in OFF mode		0.01	1.0	μA
Power Supply Rejection Ratio	PSRR	Ripple 0.5Vp-p $V_{IN}=3.8V$, $I_{OUT}=100mA$	$f=100Hz$		65	dB
			$f=1KHz$		65	
Output Voltage Temperature Coefficient	$(\Delta V_{OUT}/V_{OUT}) / \Delta T$	$I_{OUT}=30mA$ $T_A = -40^\circ C$ to $85^\circ C$		± 100		ppm/ $^\circ C$
Short Current Limit	I_{SHORT}	$V_{OUT}=0V$		50		mA
RMS Output Noise	V_{NOISE}	No Load, $10Hz \leq f \leq 100kHz$		50		μV_{RMS}
V_{EN} High Voltage	V_{IH}	Enable logic high, regulator on	1.5		6.0	V
V_{EN} Low Voltage	V_{IL}	Enable logic low, regulator off	0		0.4	
Start-up Time	t_S	No Load		20		μs
EN Pull Down Resistor	R_{PD}			3.0		$M\Omega$
V_{OUT} Discharge Resistor	R_{DCHG}	Set EN pin at Low		60		Ω
Thermal Shutdown Temperature	T_{OTSD}			160		$^\circ C$
Thermal Shutdown Hysteresis	T_{HYOTSD}			25		
Thermal Resistance	θ_{JC}	SOT-23-5		96		$^\circ C/W$
		SOIC-8		75		
		SOT-89-5		47		

Note 2: To prevent the Short Circuit Current protection feature from being prematurely activated, the input voltage must be applied before a current source load is applied.

Note 3: Production testing at $T_A=25^\circ C$. Over temperature specifications guaranteed by design only.



600mA CMOS LDO REGULATOR WITH ENABLE

AP2112

Electrical Characteristics (Continued)

AP2112-3.3 Electrical Characteristic (Note 2)

$V_{IN}=4.3V$, $C_{IN}=1.0\mu F$ (Ceramic), $C_{OUT}=1.0\mu F$ (Ceramic), Typical $T_A=25^\circ C$, unless otherwise specified (Note 3).

Parameter	Symbol	Test Conditions	Min	Typ	Max	Unit
Output Voltage	V_{OUT}	$V_{IN}=4.3V$, $1mA \leq I_{OUT} \leq 30mA$	$V_{OUT} * 98.5\%$	3.3	$V_{OUT} * 101.5\%$	V
Maximum Output Current	$I_{OUT(MAX)}$	$V_{IN}=4.3V$, $V_{OUT}=3.251V$ to $3.350V$	600			mA
Load Regulation	$(\Delta V_{OUT}/V_{OUT}) / \Delta I_{OUT}$	$V_{IN}=4.3V$, $1mA \leq I_{OUT} \leq 600mA$	-1	0.2	1	%/A
Line Regulation	$(\Delta V_{OUT}/V_{OUT}) / \Delta V_{IN}$	$4.3V \leq V_{IN} \leq 6V$, $I_{OUT}=30mA$	-0.1	0.02	0.1	%/V
Dropout Voltage	V_{DROP}	$I_{OUT}=10mA$		5	8	mV
		$I_{OUT}=300mA$		125	200	
		$I_{OUT}=600mA$		250	400	
Quiescent Current	I_Q	$V_{IN}=4.3V$, $I_{OUT}=0mA$		55	80	μA
Standby Current	I_{STD}	$V_{IN}=4.3V$, V_{EN} in OFF mode		0.01	1.0	μA
Power Supply Rejection Ratio	PSRR	Ripple 0.5Vp-p $V_{IN}=4.3V$, $I_{OUT}=100mA$	$f=100Hz$		65	dB
			$f=1KHz$		65	
Output Voltage Temperature Coefficient	$(\Delta V_{OUT}/V_{OUT}) / \Delta T$	$I_{OUT}=30mA$ $T_A=-40^\circ C$ to $85^\circ C$		± 100		ppm/ $^\circ C$
Short Current Limit	I_{SHORT}	$V_{OUT}=0V$		50		mA
RMS Output Noise	V_{NOISE}	No Load, $10Hz \leq f \leq 100kHz$		50		μV_{RMS}
V_{EN} High Voltage	V_{IH}	Enable logic high, regulator on	1.5		6.0	V
V_{EN} Low Voltage	V_{IL}	Enable logic low, regulator off	0		0.4	
Start-up Time	t_S	No Load		20		μs
EN Pull Down Resistor	R_{PD}			3.0		$M\Omega$
V_{OUT} Discharge Resistor	R_{DCHG}	Set EN pin at Low		60		Ω
Thermal Shutdown Temperature	T_{OTSD}			160		$^\circ C$
Thermal Shutdown Hysteresis	T_{HYOTSD}			25		
Thermal Resistance	θ_{JC}	SOT-23-5		96		$^\circ C/W$
		SOIC-8		75		
		SOT-89-5		47		

Note 2: To prevent the Short Circuit Current protection feature from being prematurely activated, the input voltage must be applied before a current source load is applied.

Note 3: Production testing at $T_A=25^\circ C$. Over temperature specifications guaranteed by design only.



600mA CMOS LDO REGULATOR WITH ENABLE

AP2112

Electrical Characteristics (Continued)

AP2112-ADJ Electrical Characteristic (Note 2)

$V_{IN}=2.5V$, $C_{IN}=1.0\mu F$ (Ceramic), $C_{OUT}=1.0\mu F$ (Ceramic), Typical $T_A=25^\circ C$, unless otherwise specified (Note 3).

Parameter	Symbol	Conditions	Min	Typ	Max	Unit
Reference Voltage	V_{REF}	$V_{IN}=2.5V$, $1mA \leq I_{OUT} \leq 30mA$	$V_{REF} \times 98.5\%$	0.8	$V_{REF} \times 101.5\%$	V
Maximum Output Current	$I_{OUT(Max)}$	$V_{IN}=2.5V$, $V_{REF}=0.788V$ to $0.812V$	600			mA
Load Regulation	$(\Delta V_{OUT}/V_{OUT})/\Delta I_{OUT}$	$V_{IN}=2.5V$, $1mA \leq I_{OUT} \leq 600mA$	-1	0.2	1	%/A
Line Regulation	$(\Delta V_{OUT}/V_{OUT})/\Delta V_{IN}$	$2.5V \leq V_{IN} \leq 6V$, $I_{OUT}=30mA$	-0.1	0.02	0.1	%/V
Quiescent Current	I_Q	$V_{IN}=2.5V$, $I_{OUT}=0mA$		55	80	μA
Standby Current	I_{STD}	$V_{IN}=2.5V$, V_{EN} in OFF mode		0.01	1.0	μA
Power Supply Rejection Ratio	PSRR	Ripple 0.5Vp-p $V_{IN}=2.5V$, $I_{OUT}=100mA$	$f=100Hz$	65		dB
			$f=1kHz$	65		
Output Voltage Temperature Coefficient	$(\Delta V_{OUT}/V_{OUT})/\Delta T$	$I_{OUT}=30mA$ $T_A=-40^\circ C$ to $85^\circ C$		± 100		ppm/ $^\circ C$
Short Current Limit	I_{SHORT}	$V_{OUT}=0V$		50		mA
RMS Output Noise	V_{NOISE}	No Load, $10Hz \leq f \leq 100kHz$		50		μV_{RMS}
VEN High Voltage	V_{IH}	Enable logic high, regulator on	1.5		6.0	V
VEN Low Voltage	V_{IL}	Enable logic low, regulator off	0		0.4	
Start-up Time	t_S	No Load		20		μs
EN Pull Down Resistor	R_{PD}			3.0		$M\Omega$
VOUT Discharge Resistor	R_{DCHG}	Set EN pin at Low		60		Ω
Thermal Shutdown Temperature	T_{OTSD}			160		$^\circ C$
Thermal Shutdown Hysteresis	T_{HYOTSD}			25		
Thermal Resistance	θ_{JC}	SOT-23-5		96		$^\circ C/W$

Note 2: To prevent the Short Circuit Current protection feature from being prematurely activated, the input voltage must be applied before a current source load is applied.

Note 3: Production testing at $T_A=25^\circ C$. Over temperature specifications guaranteed by design only.

Typical Performance Characteristics

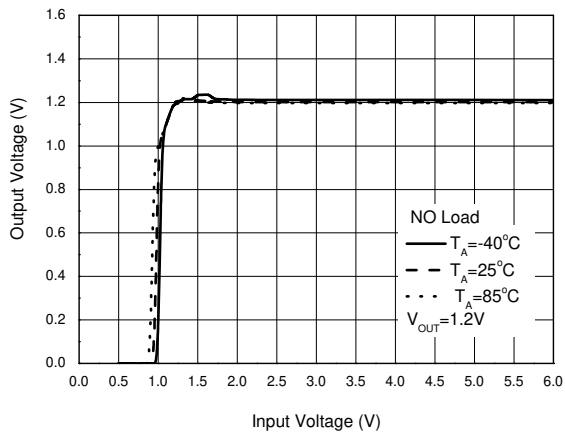

Figure 5. Output Voltage vs. Input Voltage

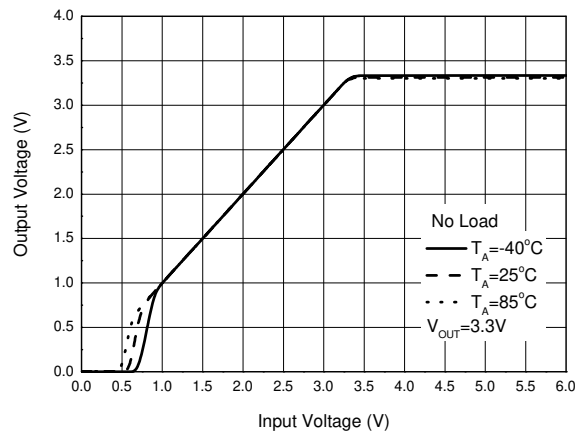

Figure 6. Output Voltage vs. Input Voltage

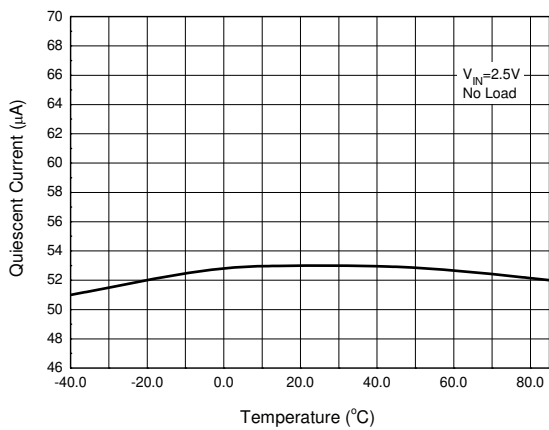

Figure 7. Quiescent Current vs. Temperature

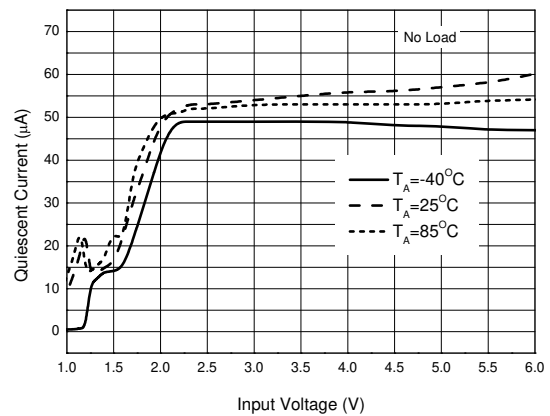

Figure 8. Quiescent Current vs. Input Voltage

Typical Performance Characteristics (Continued)

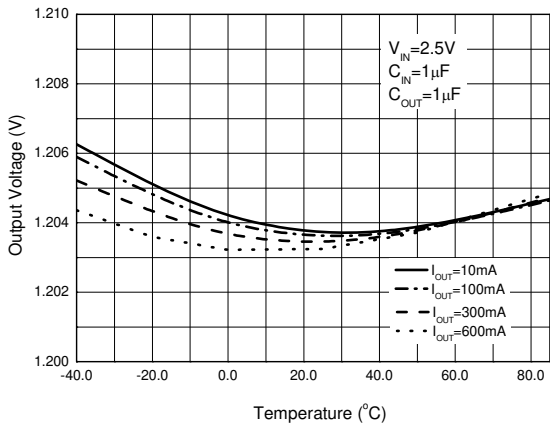

Figure 9. Output Voltage vs. Temperature

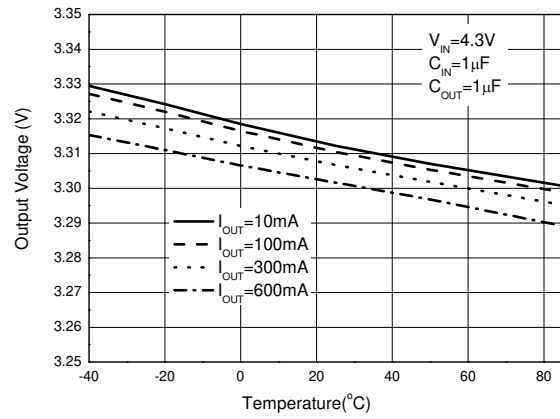

Figure 10. Output Voltage vs. Temperature

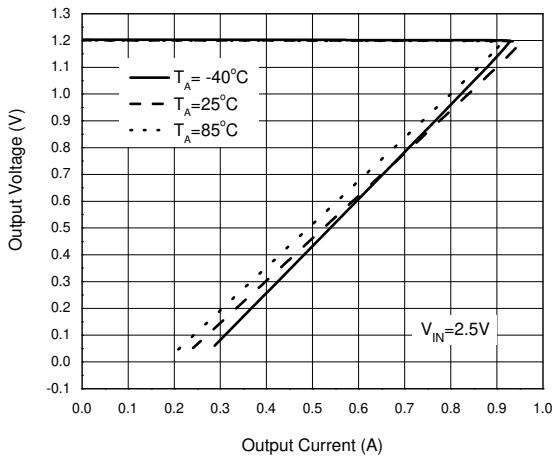

Figure 11. Output Voltage vs. Output Current

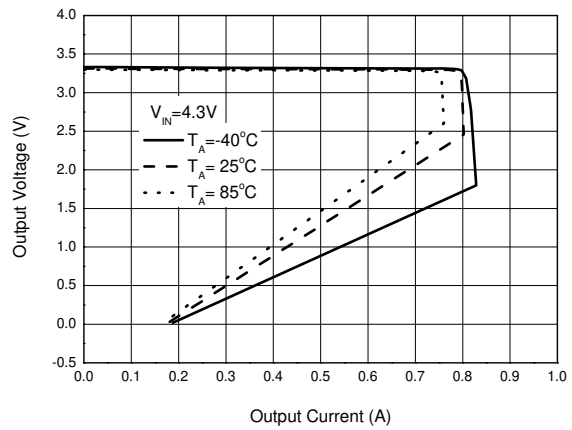

Figure 12. Output Voltage vs. Output Current

Typical Performance Characteristics (Continued)

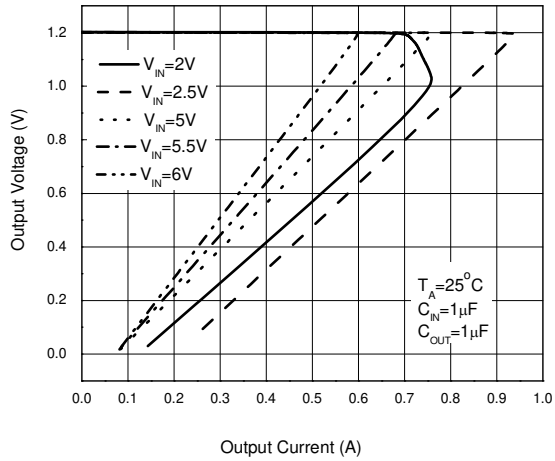

Figure 13. Output Voltage vs. Output Current

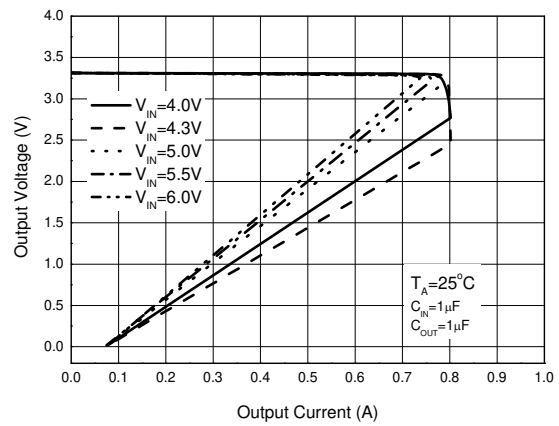

Figure 14. Output Voltage vs. Output Current

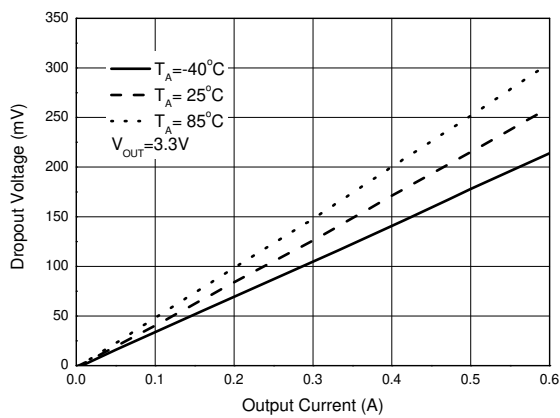

Figure 15. Dropout Voltage vs. Output Current

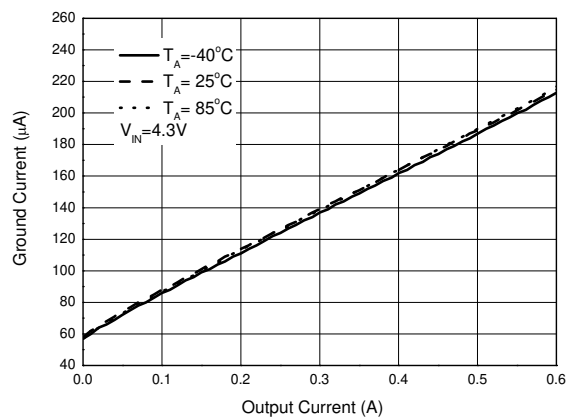

Figure 16. Ground Current vs. Output Current

600mA CMOS LDO REGULATOR WITH ENABLE

AP2112

Typical Performance Characteristics (Continued)

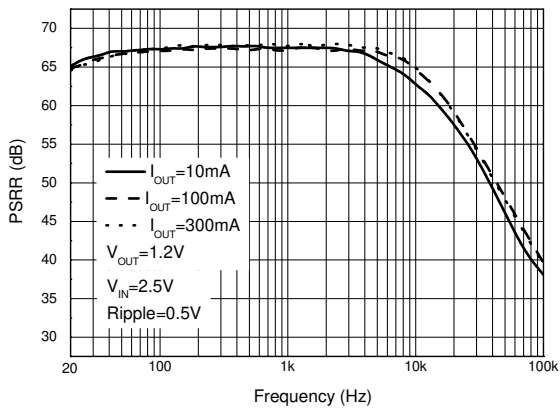

Figure 17. PSRR vs. Frequency

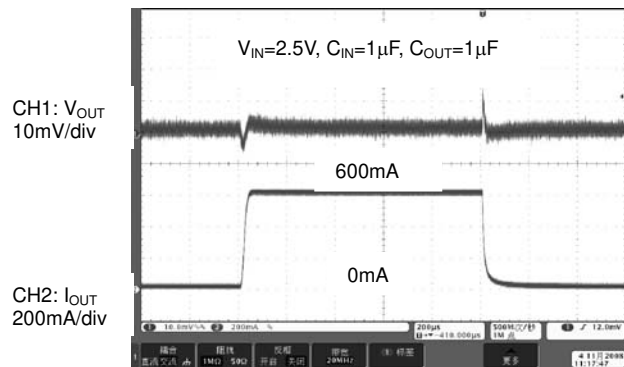

Figure 18. Load Transient

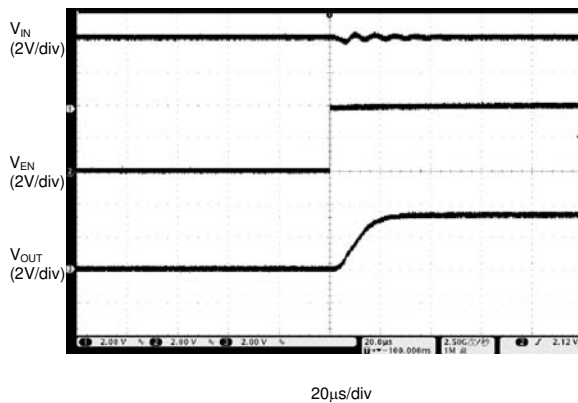

Figure 19. Enable On

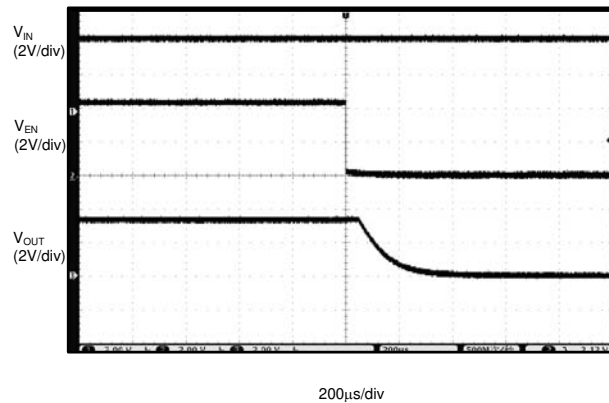
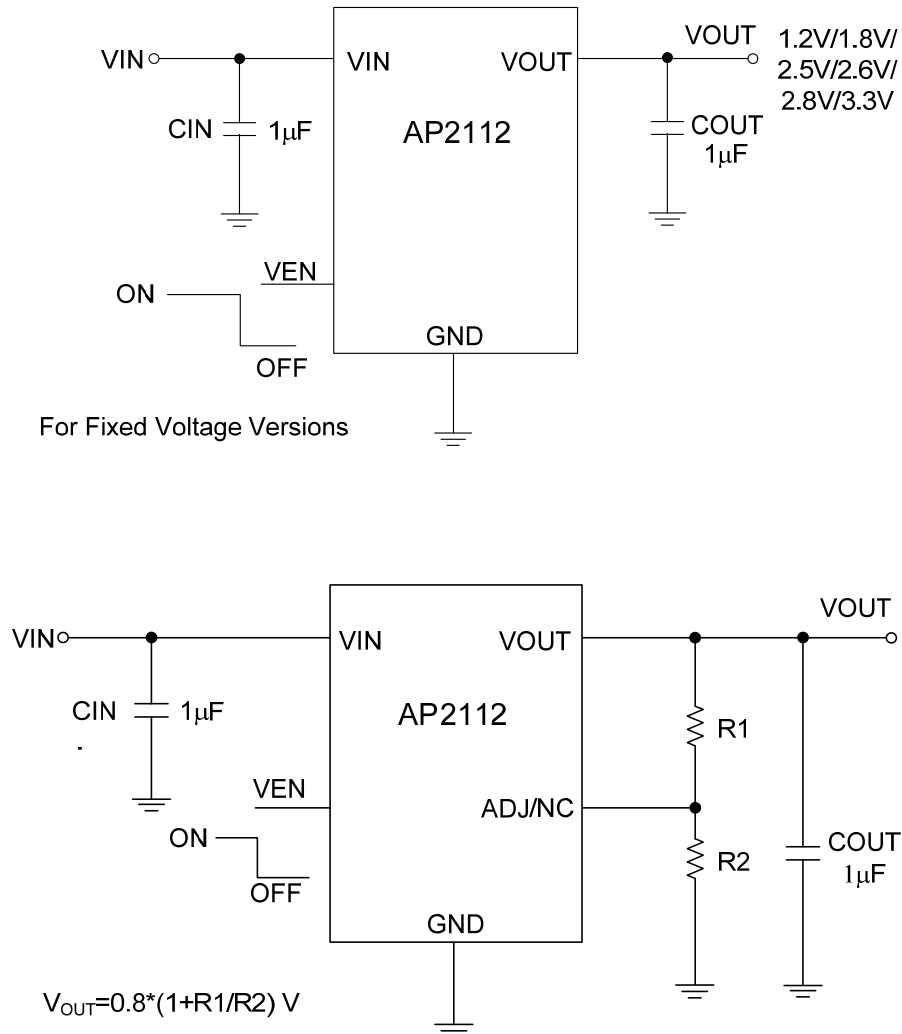

Figure 20. Enable Off

Typical Application (Note 4)

Note 4: It is recommended to use X7R or X5R dielectric capacitor if 1.0µF ceramic capacitor is selected as input/output capacitors.

Figure 21. AP2112 Typical Application

Mechanical Dimensions

SOT-23-5

Unit: mm(inch)

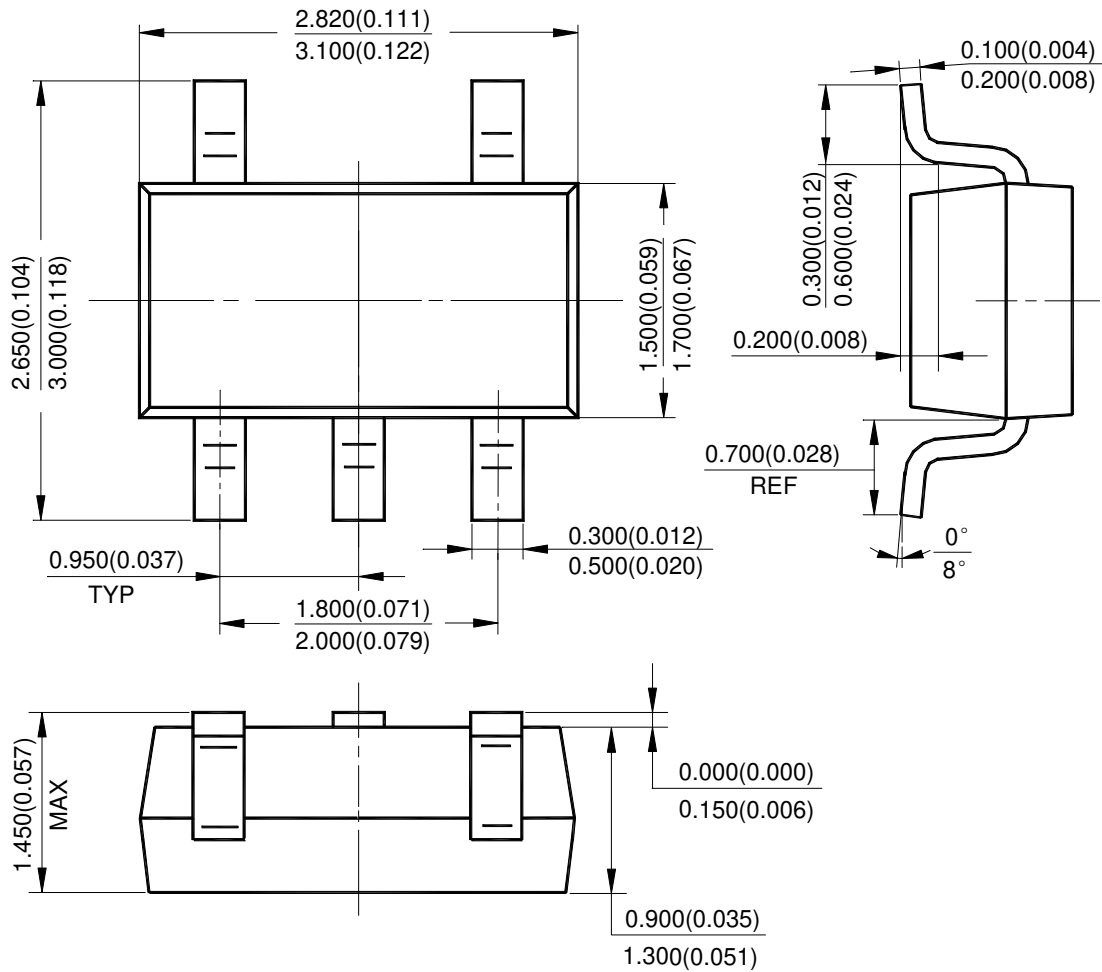

Mechanical Dimensions (Continued)

SOT-89-5

Unit: mm(inch)

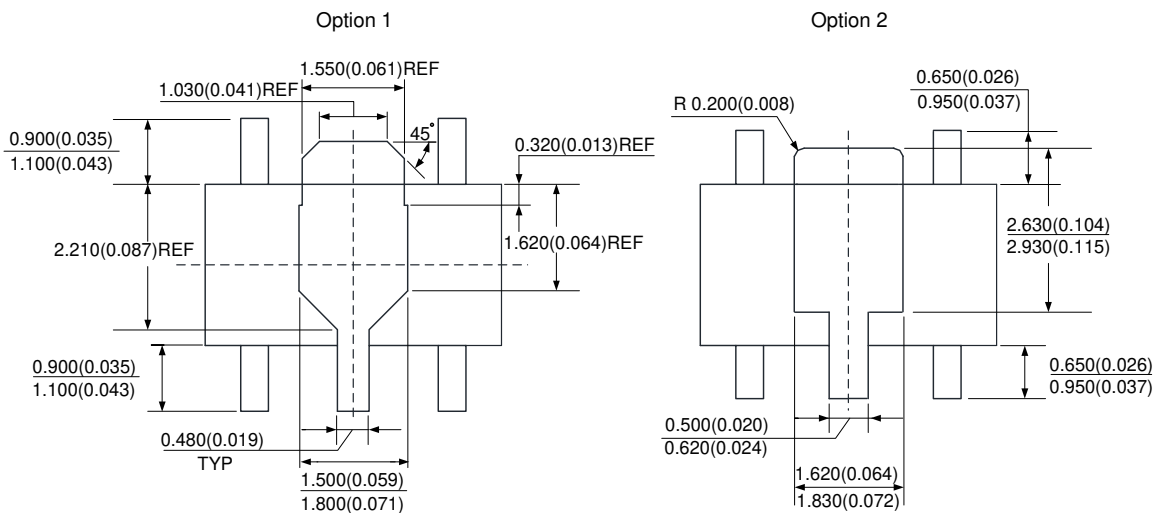
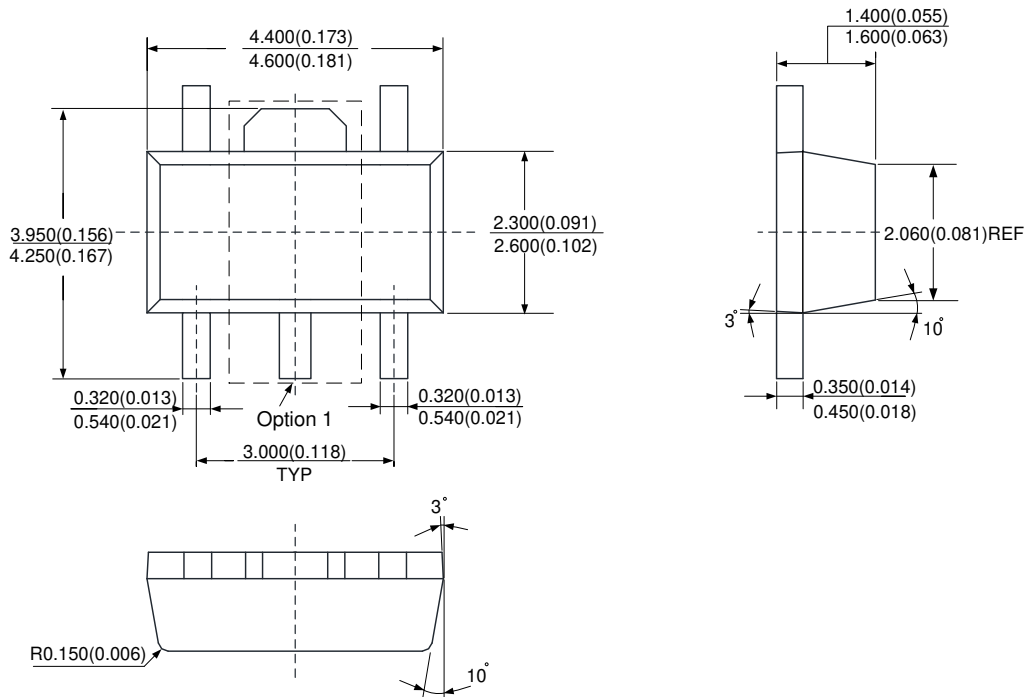



BCD Semiconductor Manufacturing Limited

<http://www.bcdsemi.com>

IMPORTANT NOTICE

BCD Semiconductor Manufacturing Limited reserves the right to make changes without further notice to any products or specifications herein. BCD Semiconductor Manufacturing Limited does not assume any responsibility for use of any its products for any particular purpose, nor does BCD Semiconductor Manufacturing Limited assume any liability arising out of the application or use of any its products or circuits. BCD Semiconductor Manufacturing Limited does not convey any license under its patent rights or other rights nor the rights of others.

MAIN SITE

- Headquarters

BCD (Shanghai) Micro-electronics Limited

No. 1600, Zi Xing Road, Shanghai ZiZhu Science-based Industrial Park, 200241, P. R. C.
Tel: +86-021-2416-2266, Fax: +86-021-2416-2277

- Wafer Fab

Shanghai SIM-BCD Semiconductor Manufacturing Co., Ltd.

800 Yishan Road, Shanghai 200233, China
Tel: +021-6485-1491, Fax: +86-021-5450-0008

REGIONAL SALES OFFICE

Shenzhen Office

Shanghai SIM-BCD Semiconductor Manufacturing Co., Ltd., Shenzhen Office

Unit A Room 1203, Skyworth Bldg., Gaoxin Ave.1.S., Nanshan District
Shenzhen 518057, China

Tel: +86-0755-8660-4900, Fax: +86-0755-8660-4958

Taiwan Office (Taipei)

BCD Semiconductor (Taiwan) Company Limited

3F, No.17, Lane 171, Sec. 2, Jiu-Zong Rd., Nei-Hu Dist., Taipei(114), Taiwan, R.O.C
Tel: +886-2-2656-2808

Fax: +886-2-2656-2806/26562950

Taiwan Office (Hsinchu)

BCD Semiconductor (Taiwan) Company Limited

8F, No.176, Sec. 2, Gong-Dao 5th Road, East District
HsinChu City 300, Taiwan, R.O.C

Tel: +886-3-5160181, Fax: +886-3-5160181

USA Office

BCD Semiconductor Corp.

48460 Kato Road, Fremont, CA 94538, USA
Tel: +1-510-668-1950

Fax: +1-510-668-1990

Korea Office

BCD Semiconductor Limited Korea office.

Room 101-1112, Digital-Empire II, 486 Sin-dong,
Yeongtong-Gu, Suwon-city, Gyeonggi-do, Korea

Tel: +82-31-695-8430