



Chipsmall Limited consists of a professional team with an average of over 10 year of expertise in the distribution of electronic components. Based in Hongkong, we have already established firm and mutual-benefit business relationships with customers from,Europe,America and south Asia,supplying obsolete and hard-to-find components to meet their specific needs.

With the principle of “Quality Parts,Customers Priority,Honest Operation,and Considerate Service”,our business mainly focus on the distribution of electronic components. Line cards we deal with include Microchip,ALPS,ROHM,Xilinx,Pulse,ON,Everlight and Freescale. Main products comprise IC,Modules,Potentiometer,IC Socket,Relay,Connector.Our parts cover such applications as commercial,industrial, and automotives areas.

We are looking forward to setting up business relationship with you and hope to provide you with the best service and solution. Let us make a better world for our industry!



Contact us

Tel: +86-755-8981 8866 Fax: +86-755-8427 6832

Email & Skype: info@chipsmall.com Web: www.chipsmall.com

Address: A1208, Overseas Decoration Building, #122 Zhenhua RD., Futian, Shenzhen, China



General Description

AP3021 is a constant 330kHz, voltage mode, external compensation boost controller. The IC has low reference voltage which makes it ideal for low cost LED backlight supplies. It can support DC dimming.

AP3021 employs complete protection to ensure system security. The device integrates Under Voltage Lockout, Over Voltage Protection, and Over Temperature Protection to protect the circuit.

To satisfy the requirements for small mounting space constraints, AP3021 is available in SOIC-8 package to save space.

Features

- Voltage Mode PWM Controller
- Low Feedback Voltage: 0.2V
- Fixed Frequency: 330kHz
- DC Dimming
- Low Shutdown Current: 0.1 μ A
- External Compensation
- Built-in UVLO Function
- Built-in OVP
- Built-in OTP

Applications

- LED TV
- LED Monitor
- LED Display Module



Figure 1. Package Type of AP3021

Pin Configuration

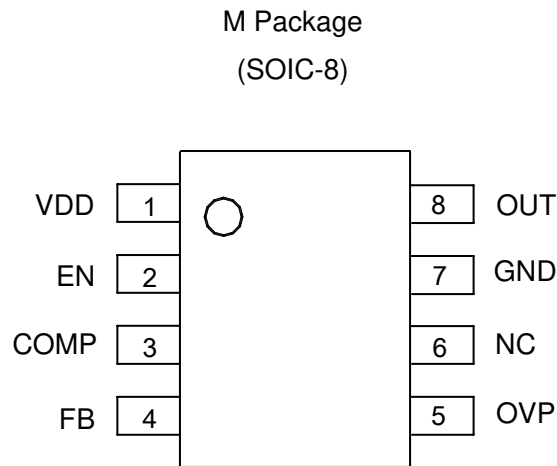

Figure 2. Pin Configuration of AP3021 (Top View)

Pin Description

Pin Number	Pin Name	Function
1	VDD	Supply input pin. A capacitor should be connected between the VDD pin and GND pin to keep the DC input voltage constant
2	EN	Enable and dimming Pin. When EN input voltage is lower than 0.3V, disable IC. When EN input voltage works at 0.5V to 2.4V, enable DC dimming. When EN input voltage is higher than 2.6V, enable IC
3	COMP	Compensation pin. This pin is the output of the internal error amplifier. COMP is forced to low when $V_{DD} < 3.6V$
4	FB	Feedback pin. This pin is connected to an external resistor divider to program the system output voltage
5	OVP	Over voltage detection pin
6	NC	No connection
7	GND	Ground pin
8	OUT	Output pin, this pin is connected to external MOSFET gate to turn it on/off

PWM Controller

AP3021

Functional Block Diagram

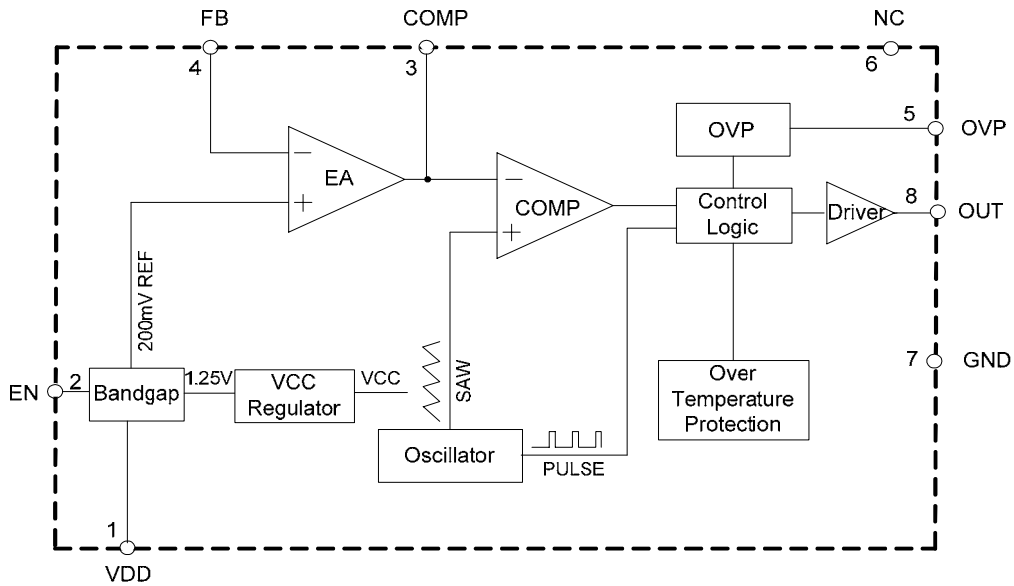
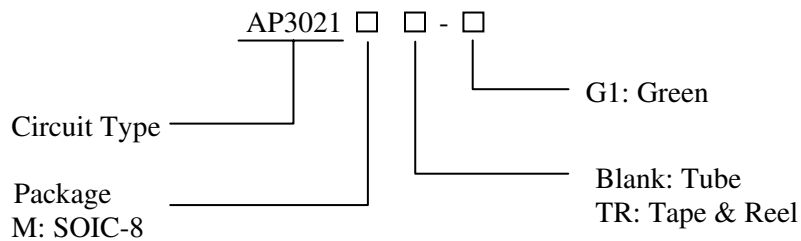

Figure 3. Functional Block Diagram of AP3021

Ordering Information



Package	Temperature Range	Part Number	Marking ID	Packing Type
SOIC-8	-40 to 85°C	AP3021M-G1	3021M-G1	Tube
		AP3021MTR-G1	3021M-G1	Tape & Reel

BCD Semiconductor's Pb-free products, as designated with "G1" suffix in the part number, are RoHS compliant and green.

**PWM Controller****AP3021****Absolute Maximum Ratings (Note 1)**

Parameter	Symbol	Value	Unit
VDD Pin Voltage	V_{DD}	-0.3 to 20	V
EN Pin Voltage	V_{EN}	-0.3 to $V_{DD}+0.3$	V
OUT Pin Voltage	V_{OUT}	20	V
OVP Pin Voltage	V_{OVP}	7	V
Feedback Pin Voltage	V_{FB}	-0.3 to 5.5	V
Thermal Resistance	θ_{JA}	105	°C/W
Operating Junction Temperature	T_J	150	°C
Storage Temperature	T_{STG}	-65 to 150	°C
Lead Temperature (Soldering, 10sec)	T_{LEAD}	260	°C

Note 1: Stresses greater than those listed under “Absolute Maximum Ratings” may cause permanent damage to the device. These are stress ratings only, and functional operation of the device at these or any other conditions beyond those indicated under “Recommended Operating Conditions” is not implied. Exposure to “Absolute Maximum Ratings” for extended periods may affect device reliability.

Recommended Operating Conditions

Parameter	Symbol	Min	Max	Unit
Input Voltage	V_{DD}	4.0	18	V
Operating Ambient Temperature	T_A	-40	85	°C



PWM Controller

AP3021

Electrical Characteristics

$V_{DD}=5V$, $T_A=25^{\circ}C$, unless otherwise specified.

Parameters	Symbol	Conditions	Min	Typ	Max	Unit
SUPPLY VOLTAGE (VDD PIN)						
Input Voltage	V_{DD}		4.0		18	V
Quiescent Current	I_Q	$V_{FB}=0.3V$		5		mA
Shutdown Current	I_{SHDN}	$V_{EN}=0V$		0.1		μA
UNDER VOLTAGE LOCKOUT						
Input UVLO Threshold	V_{UVLO}	V_{DD} Rising		3.8		V
Input UVLO Hysteresis	V_{HYS}		100	200	300	mV
OVER VOLTAGE PROTECTION						
Over Voltage Threshold			1.45	1.55	1.65	V
OVER TEMPERATURE PROTECTION						
Thermal Shutdown Temperature	T_{OTSD}			160		$^{\circ}C$
Thermal Shutdown Hysteresis				20		$^{\circ}C$
ENABLE (EN PIN)						
EN Pin Threshold	V_{EN-OFF}		0.3			V
	V_{EN-ON}				2.6	V
EN Pin Dimming Threshold	V_{EN-DIM}		0.4	0.5		V
				2.4	2.6	V
VOLTAGE REFERENCE (FB PIN)						
Feedback Voltage	V_{FB}		0.194	0.2	0.206	V
Feedback Bias Current	I_{FB}			35	100	nA
Line Regulation		$V_{DD}=4.5V$ to $8V$ $T_A=25^{\circ}C$		2	20	mV
		$V_{DD}=8V$ to $18V$ $T_A=25^{\circ}C$		4	40	mV
OUTPUT						
Oscillator Frequency	f_{OSC}		247	330	412	kHz
Maximum Duty Cycle	D_{MAX}		85	90	95	%
OUT Voltage (Note2)	V_{OUT}	$I_{OUT}=10mA$		$V_{DD}-1$		V
Rising Time	t_{RISE}	Output Pin Load=1nF		65.5		ns
Falling Time	t_{FALL}			88.5		ns

Note 2: Guaranteed by design.

Operation Description

1. PWM Operation

The AP3021 uses a constant frequency, voltage mode control scheme to provide excellent line and load regulation. To drive LED load, AP3021 can be connected as current regulator (Figure 5) or voltage regulator (Figure 6), both topologies can realize LED lighting and dimming. Load regulation is less than 3% even if AP3021 is connected as voltage regulator. The maximum duty cycle of the PWM controller is limited to 93%. For more information please refer to the functional block diagram (Figure 3).

2. Enable Control

The EN pin is used to turn on and off the controller. When EN input voltage is lower than 0.3V, the controller turns off and the shutdown current can be limited under 0.1 μ A. When EN input voltage goes higher than 2.6V, the controller turns on and the feedback voltage is set to 0.2V. When EN voltage works at 0.5V to 2.4V, the IC will operate in dimming mode, more details please refer to section 4.

The AP3021 has an internal $80\pm 15\%$ k Ω pull low resistor on the EN pin, thus the device is normally in the OFF state or shutdown mode operation.

3. Soft Start Control

The AP3021 external compensation circuit can clamp the output waveform to soft start smoothly.

4. DC Dimming Control

The DC Dimming is to inject a constant DC voltage to EN pin. The feedback voltage is indirectly adjusted when the EN pin voltage is between 0.5V to 2.4V, which can be used as dimming control. Application in Figure 4 is designed so that a voltage signal of 0.5V to 2.4V varies the LED current from minimum output current to maximum output current. Comparing with all kinds of dimming control, this method features a best output voltage and LEDs current.

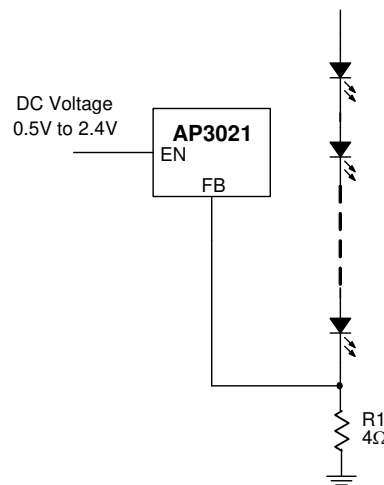

Figure 4. Dimming Control Using A DC Voltage Signal in EN Pin

5. Operation Protection

5.1 Over Voltage Protection

The controller has an internal OVP circuit. The controller output voltage will boost too high when LEDs are disconnected from the circuit or fail open. The AP3021 will latch off the output if the OVP pin senses a voltage that is higher than 1.55V, and the power switching will be turned off. The latched off status can be reset by reducing the supply voltage to lower than 3.6V.

5.2 UVLO

The AP3021 provides an under voltage lockout circuit to prevent it from undefined status when startup. The UVLO circuit turns the driver off when supply voltage drops below 3.6V. The UVLO circuit has 200mV hysteresis, which means the device starts up again when V_{DD} rises to 3.8V.

5.3 OTP

The AP3021 monitors the temperature of itself. If the temperature exceeds the threshold value (typically 160°C), the AP3021 shuts itself off. This is a no-latched protection. The device recovers once the temperature has decreased approximately 20°C.

Typical Application

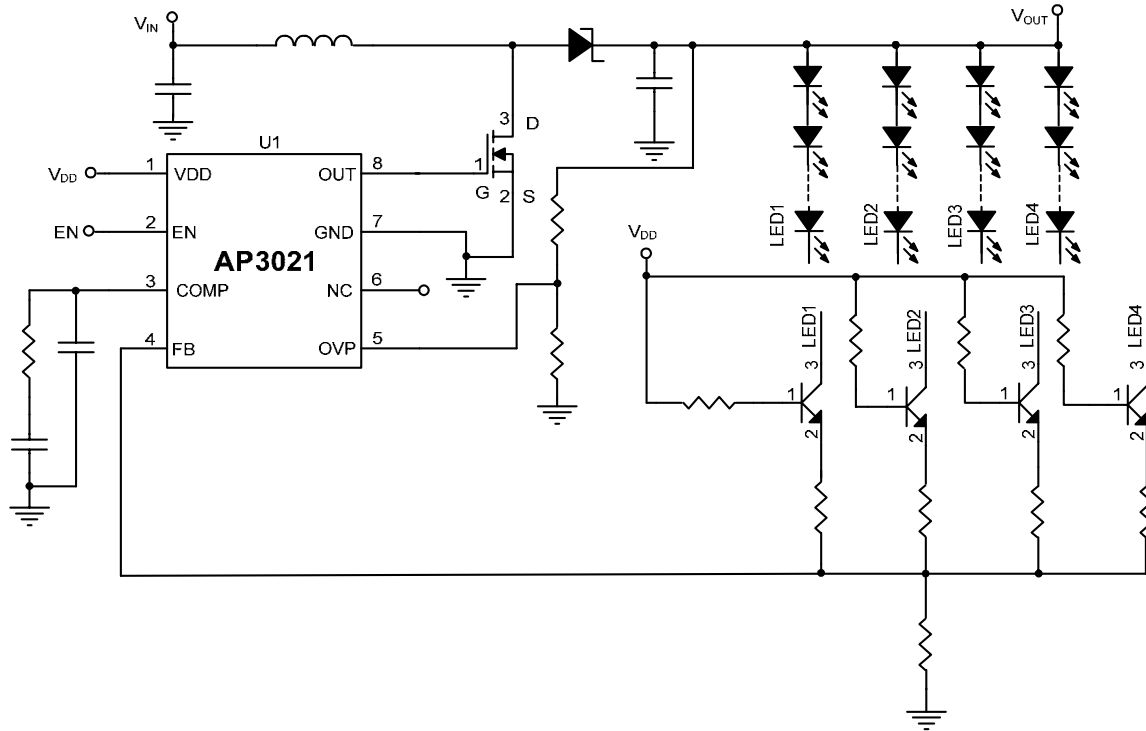

Figure 5. Current Regulator to Drive LEDs

Typical Application (Continued)

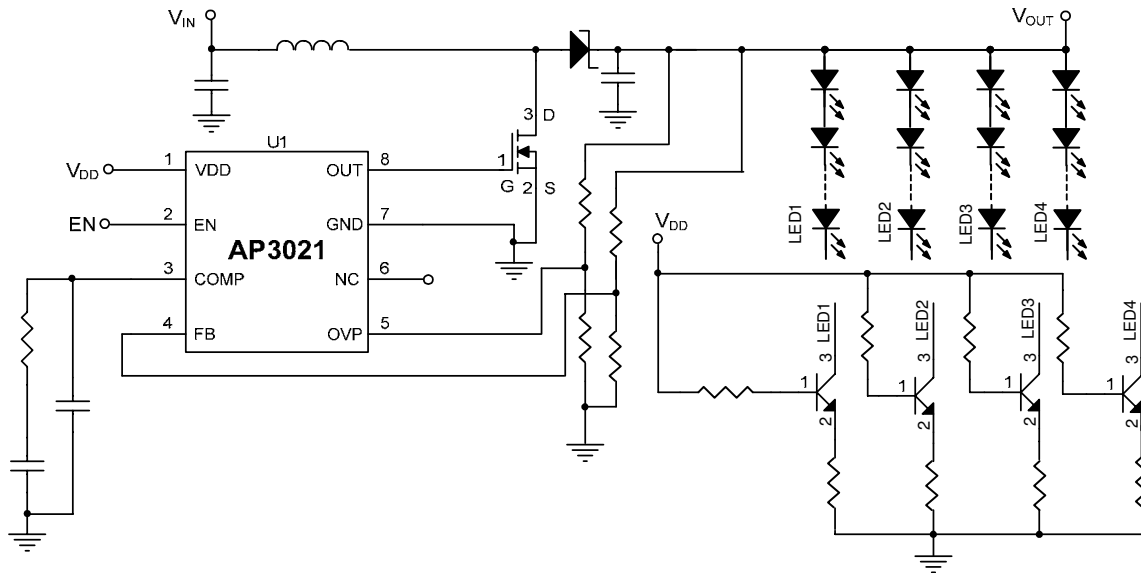

Figure 6. Voltage Regulator to Drive LEDs



BCD Semiconductor Manufacturing Limited

<http://www.bcdsemi.com>

IMPORTANT NOTICE

BCD Semiconductor Manufacturing Limited reserves the right to make changes without further notice to any products or specifications herein. BCD Semiconductor Manufacturing Limited does not assume any responsibility for use of any its products for any particular purpose, nor does BCD Semiconductor Manufacturing Limited assume any liability arising out of the application or use of any its products or circuits. BCD Semiconductor Manufacturing Limited does not convey any license under its patent rights or other rights nor the rights of others.

MAIN SITE

- Headquarters

BCD Semiconductor Manufacturing Limited

No. 1600, Zi Xing Road, Shanghai ZiZhu Science-based Industrial Park, 200241, China
Tel: +86-21-24162266, Fax: +86-21-24162277

- Wafer Fab

Shanghai SIM-BCD Semiconductor Manufacturing Co., Ltd.

800 Yi Shan Road, Shanghai 200233, China
Tel: +86-21-6485 1491, Fax: +86-21-5450 0008

REGIONAL SALES OFFICE

Shenzhen Office

Shanghai SIM-BCD Semiconductor Manufacturing Co., Ltd., Shenzhen Office

Unit A Room 1203, Skyworth Bldg., Gaoxin Ave. 1.S., Nanshan District, Shenzhen, China
Tel: +86-755-8826 7951
Fax: +86-755-8826 7865

Taiwan Office

BCD Semiconductor (Taiwan) Company Limited

4F, 298-1, Rui Guang Road, Nei-Hu District, Taipei, Taiwan
Tel: +886-2-2656 2808
Fax: +886-2-2656 2806

USA Office

BCD Semiconductor Corp.

30920 Huntwood Ave. Hayward, CA 94544, USA
Tel : +1-510-324-2988
Fax: +1-510-324-2788