



Chipsmall Limited consists of a professional team with an average of over 10 year of expertise in the distribution of electronic components. Based in Hongkong, we have already established firm and mutual-benefit business relationships with customers from,Europe,America and south Asia,supplying obsolete and hard-to-find components to meet their specific needs.

With the principle of "Quality Parts,Customers Priority,Honest Operation,and Considerate Service",our business mainly focus on the distribution of electronic components. Line cards we deal with include Microchip,ALPS,ROHM,Xilinx,Pulse,ON,Everlight and Freescale. Main products comprise IC,Modules,Potentiometer,IC Socket,Relay,Connector.Our parts cover such applications as commercial,industrial, and automotives areas.

We are looking forward to setting up business relationship with you and hope to provide you with the best service and solution. Let us make a better world for our industry!



## Contact us

Tel: +86-755-8981 8866 Fax: +86-755-8427 6832

Email & Skype: info@chipsmall.com Web: www.chipsmall.com

Address: A1208, Overseas Decoration Building, #122 Zhenhua RD., Futian, Shenzhen, China



## Description

The AP3108L is a Current Mode PWM controller specially designed for offline power supply that requires ultra-low standby power, high-power density and comprehensive protection. The AP3108L coordinating with Diodes' secondary side controller, such as the AP4320, can be applied in the situation that requires for constant CC and constant CV.

The maximum switching frequency of the AP3108L is set at 65kHz. The switching frequency can be modulated through green mode, in which it will smoothly decrease along with the decreasing load. This will cause the minimum switching frequency to be clamped at about 22kHz to avoid audible noise.

The AP3108L provides an inner high-voltage start-up function through HV pin which can save the use of the external start-up resistor, reducing the standby loss. The HV pin also realizes X-CAP discharge function. This is a useful function for power saving when an X-CAP is connected to a system, for it will discharge the X-CAP when the AC line voltage is off automatically without the need for extra discharge resistors.

The AP3108L integrates a VCC LDO circuitry, allowing the LDO to regulate the wide range  $V_{CC\_IN}$ , which is rectified from auxiliary winding to an acceptable value. This makes the AP3108L a good choice in wide range output voltage application.

There are also versatile system protections provided by AP3108L, such as secondary side OVP, secondary side UVP, constant output current limit, cycle-by-cycle current limit, brown-out protection, programmable external OTP, etc.

## Features

- Current Mode Control
- High-Voltage Startup
- Embedded VCC LDO to Guarantee Wide Range Output Voltage
- Constant, Low Output Current in Output Short Situation
- Low VCC Charge Current Reduces Standby Power in Output Short Situation
- Non-Audible-Noise Green-Mode Control
- Internal Slope Compensation
- Soft Start During Startup Process
- Frequency Fold Back for High Average Efficiency
- VCC Maintain Mode
- X-CAP Discharge Function
- Precise Secondary Side OVP and UVP
- Programmable External OTP
- Brown-Out Protection
- Overload Protection
- FOCP and SSCP Protection
- Useful Pin Fault Protection
- SSOP-9 (Type CJ) is Available
- **Totally Lead-Free & Fully RoHS Compliant (Notes 1 & 2)**
- **Halogen and Antimony Free. "Green" Device (Note 3)**

Notes: 1. No purposely added lead. Fully EU Directive 2002/95/EC (RoHS) & 2011/65/EU (RoHS 2) compliant.  
 2. See [http://www.diodes.com/quality/lead\\_free.html](http://www.diodes.com/quality/lead_free.html) for more information about Diodes Incorporated's definitions of Halogen- and Antimony-free, "Green" and Lead-free.  
 3. Halogen- and Antimony-free "Green" products are defined as those which contain <900ppm bromine, <900ppm chlorine (<1500ppm total Br + Cl) and <1000ppm antimony compounds.

## Pin Assignments

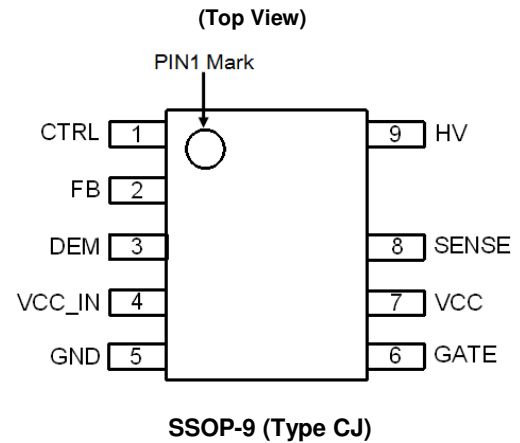

## Applications

- Switching AC-DC Adapter/Charger
- Open Frame Switching Power Supply

**Typical Applications Circuit**

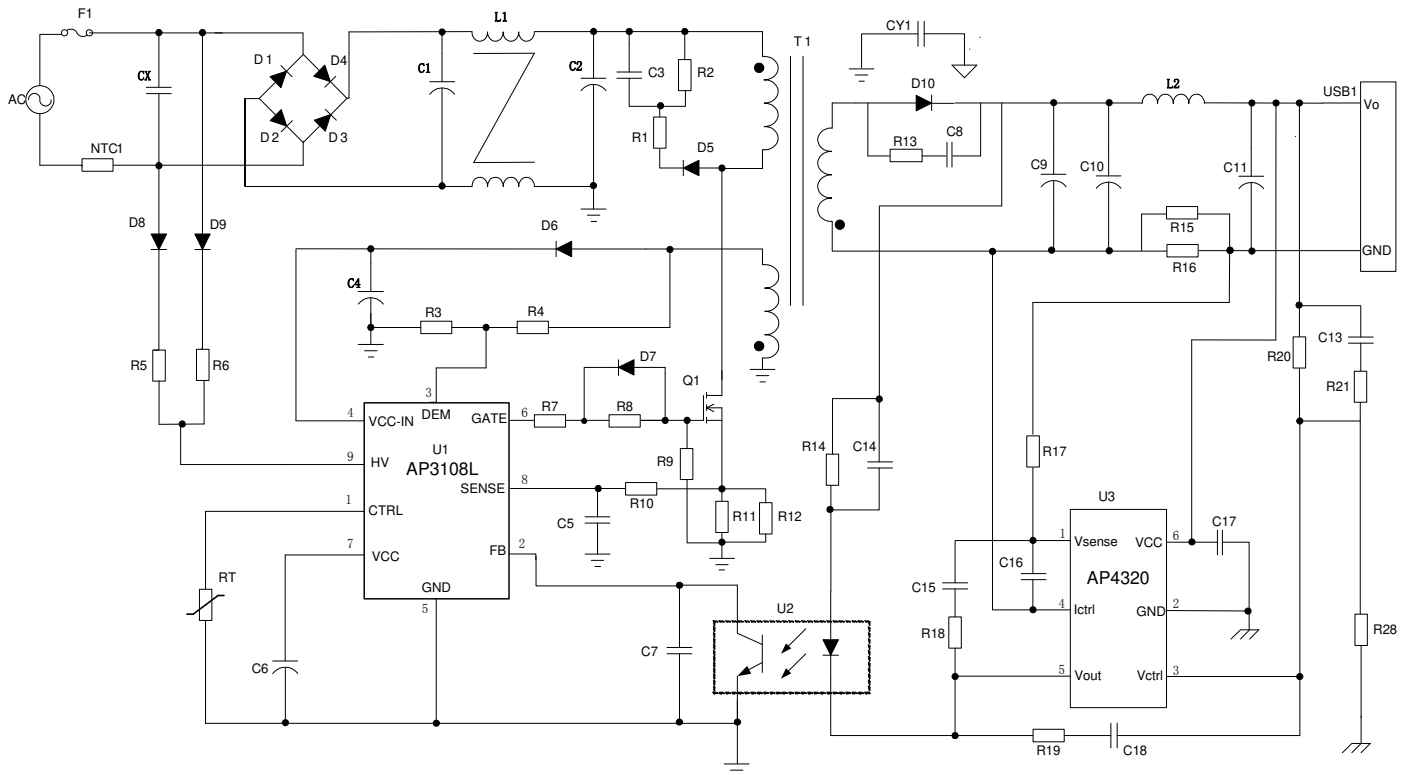

**Pin Descriptions**

Pin Name	Function	
1	CTRL	Programmable external protection
2	FB	Feedback. Directly connected to the opto-coupler
3	DEM	Sample $V_{OUT}$ to realize SOVP and SUVP protection
4	VCC_IN	Wide range input supply voltage to produce $V_{CC}$
5	GND	Signal ground
6	GATE	Gate driver output
7	VCC	Supply voltage of driver and control circuits
8	SENSE	Sense the primary current
9	HV	High Voltage Input. Sense line voltage and provide startup current to $V_{CC}$

NEW PRODUCT

**Functional Block Diagram**

NEW PRODUCT

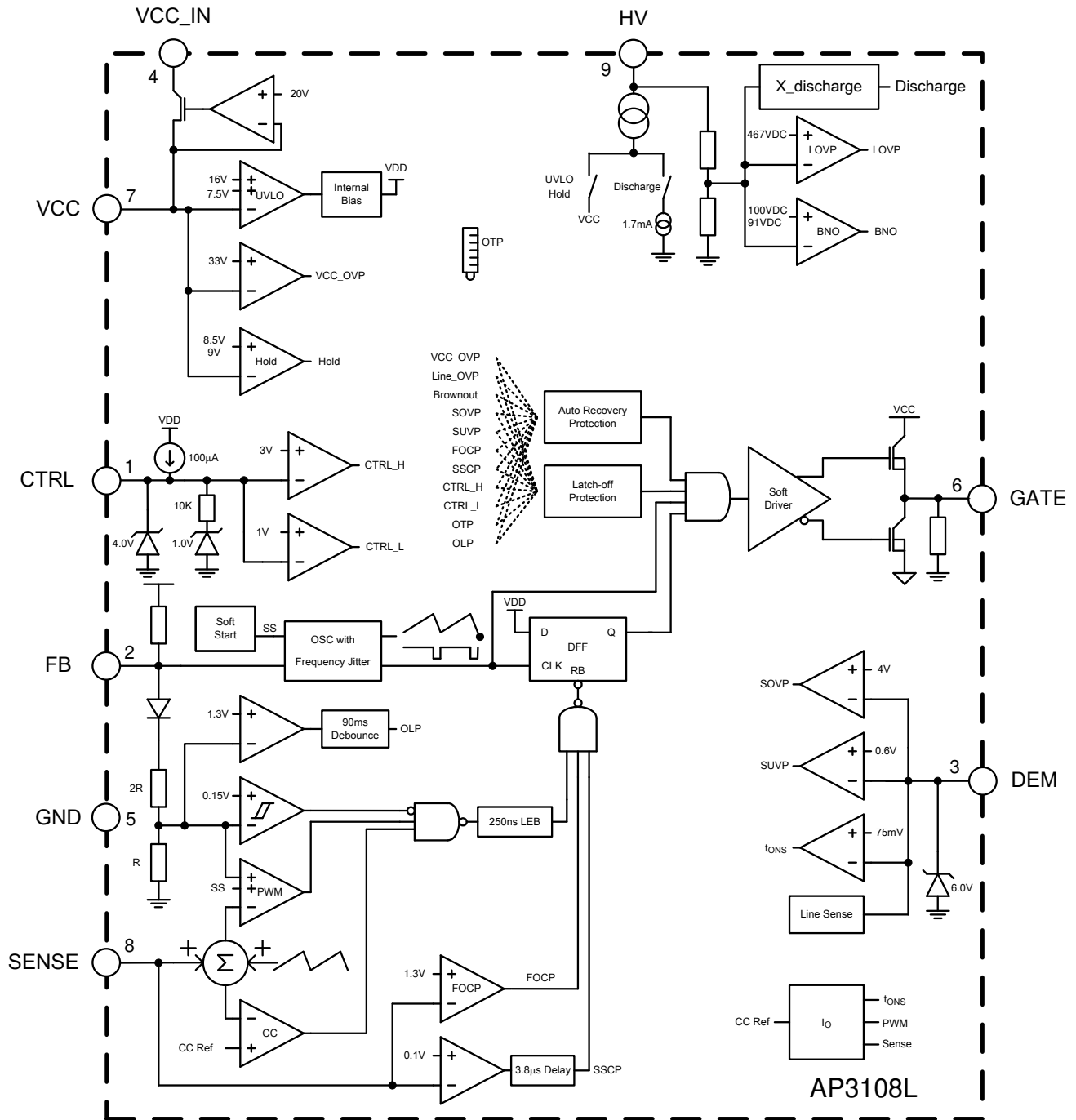

**AP3108L**

**Absolute Maximum Ratings** (Note 4)

Symbol	Parameter	Rating	Unit
$V_{HV}$	HV Pin Input Voltage	700	V
$V_{CC\_IN}$	LDO Supply Voltage	100	V
$V_{CC}$	Power Supply Voltage	40	V
$I_O$	Gate Output Current	500	mA
$V_{FB}, V_{SENSE}, V_{CTRL}, V_{DEM}$	Input Voltage to FB, SENSE, CTRL, DEM	-0.3 to 7	V
$\theta_{JA}$	Thermal Resistance (Junction to Ambient)	165	°C/W
$P_D$	Power Dissipation at $T_A < +25^\circ\text{C}$	550	mW
$T_J$	Operating Junction Temperature	-40 to +150	°C
$T_{STG}$	Storage Temperature Range	+150	°C
ESD	Human Body Model (Except HV Pin and $V_{CC\_IN}$ Pin (Note 5))	2,000	V
	Machine Model (Except HV Pin and $V_{CC\_IN}$ Pin (Note 5))	200	V

Note 4: Stresses greater than those listed under "Absolute Maximum Ratings" may cause permanent damage to the device. These are stress ratings only, and functional operation of the device at these or any other conditions beyond those indicated under "Recommended Operating Conditions" is not implied. Exposure to "Absolute Maximum Ratings" for extended periods may affect device reliability.

Note 5: ESD sensitive pins with HV device.

**Recommended Operating Conditions**

Symbol	Parameter	Min	Max	Unit
$V_{CC\_IN}$	LDO Supply Input Voltage	10	50	V
$V_{CC}$	Power Supply Voltage	10	28	V
$T_{OP}$	Operating Temperature Range	-40	+85	°C

**Electrical Characteristics** (@ $T_A = -40$  to  $+85^\circ\text{C}$ ,  $V_{CC} = 16\text{V}$ , unless otherwise specified.)

Symbol	Parameter	Condition	Min	Typ	Max	Unit
<b>Power Supply Voltage (VCC Pin)</b>						
$I_{ST}$	Startup Current	–	–	1.5	15	$\mu\text{A}$
$I_{CC}$	Operating Supply Current	$V_{FB} = 0\text{V}$ , $C_L = 1\text{nF}$	0.35	0.55	0.75	mA
		$V_{FB} = 3\text{V}$ , $C_L = 0\text{nF}$	1.2	1.7	2.2	
$V_{ST}$	Turn-On Threshold Voltage	–	15.3	15.8	16.3	V
$V_M$	VCC Maintain	–	8.1	8.5	8.9	V
$V_{CC-UVLO}$	VCC UVLO Voltage	–	7	7.5	8	V
$V_{CC-OVP}$	VCC OVP Threshold Voltage	–	32	33	34	V
<b>HV Section(HV Pin)</b>						
$I_{CHARGE-L}$	Charge Current	$V_{CC} = 0\text{V}$ , $V_{HV} = 100\text{V}$	0.1	0.2	0.35	mA
$I_{CHARGE-H}$		$V_{CC} = 6\text{V}$ , $V_{HV} = 100\text{V}$	1.5	1.8	2.2	mA
$I_{CHARGE-FAULT}$	Charge Current If Fault Occurs	$V_{CC} = 6\text{V}$ , $V_{HV} = 100\text{V}$	50	75	100	$\mu\text{A}$
$V_{BR-IN}$	Brown In Voltage	–	95	100	105	V
$V_{BR-OUT}$	Brown Out Voltage	–	87	91	95	V
$t_{BR-IN}$	Delay of Brown In (Note 8)	–	–	100	–	$\mu\text{s}$
$t_{BR-OUT}$	Delay of Brown Out (Note 8)	–	–	50	–	ms
$V_{LOVP}$	Line OVP (Note 8)	–	–	467	–	V
$I_{DISCH-X}$	X-CAP Discharge Current	–	1.3	1.7	2.1	mA
<b>PWM Section/Oscillator Section</b>						
$D_{MAX}$	Maximum Duty Cycle	–	70	75	80	%
$f_s$	Oscillation frequency	–	60	65	70	kHz
$f_{OSC-GREEN}$	Green Mode Frequency	–	18	–	30	kHz
$f_{OSC-JITTER}$	Frequency Dithering	–	$\pm 4$	$\pm 6$	$\pm 8$	%
<b>Current Sense Section (SENSE Pin)</b>						
$V_{REF}$	Inner Reference For Primary CC Control	–	2.47	2.5	2.53	V
$V_{CS-MAX}$	Maximum SENSE Voltage	$V_{FB} = 4.5\text{V}$	0.93	0.95	0.97	V
$t_{DELAY-CS}$	Delay To Output (Note 6)	–	–	100	–	ns
$V_{TH-FOCP}$	FOCP Voltage	–	1.2	1.3	1.4	V
$V_{TH-SSCP}$	SSCP Voltage	–	80	100	120	mV
$t_{LEB}$	LEB Time Of SENSE	–	200	250	300	ns
<b>Feedback Input Section (FB Pin)</b>						
$K_{FB-CS}$	The Ratio of FB Input Voltage to Current Sense Voltage	–	2.5	3	3.5	V/V
$R_{FB}$	Input Impedance	–	15	20	25	k $\Omega$

**Electrical Characteristics** (@ $T_A = -40$  to  $+85^\circ\text{C}$ ,  $V_{CC} = 16\text{V}$ , unless otherwise specified.) (Cont.)

Symbol	Parameter	Condition	Min	Typ	Max	Unit
$t_{\text{DELAY-OCP}}$	Delay of Overcurrent Protection(Note 8)	–	–	90	–	ms
$I_{\text{FB-SOURCE}}$	Source Current	$V_{\text{FB}} = 0\text{V}$	0.15	0.25	0.35	mA
$V_{\text{TH-GREEN}}$	Green Mode Threshold(Note 8)	–	–	2.3	–	V
$V_{\text{BURST}}$	Input Voltage For Zero Duty	–	1	1.2	1.4	V
<b>Output Section (GATE Pin)</b>						
$V_{\text{GATE-L}}$	Output Low-Level Voltage	$I_O = 20\text{mA}$ , $V_{CC} = 12\text{V}$	–	–	1	V
$V_{\text{GATE-H}}$	Output High-Level Voltage	$I_O = 20\text{mA}$ , $V_{CC} = 12\text{V}$	8	–	–	V
$V_{\text{GATE-CLP}}$	Output Clamping Voltage	–	9	10.5	12	V
$t_{\text{GATE-RISE}}$	Rising Time (Note 6)	$C_L = 1\text{nF}$ , $V_{CC} = 13\text{V}$	–	150	200	ns
$t_{\text{GATE-FALL}}$	Falling Time (Note 6)	$C_L = 1\text{nF}$ , $V_{CC} = 13\text{V}$	–	50	100	ns
<b>De-magnetization Section (DEM Pin)</b>						
$V_{\text{TH-DEM}}$	De-Magnetization Voltage(Note 8)	–	–	75	–	mV
$V_{\text{CLP-L}}$	Clamping Voltage	$I_{\text{DEM}} = -200\mu\text{A}$ (Source Current)	–	-5	–	mV
$V_{\text{CLP-H}}$		$I_{\text{DEM}} = 1\text{mA}$ (Sink Current)	–	6	–	V
$V_{\text{TH-SOVP}}$	SOVP Threshold	–	3.9	4	4.1	V
$V_{\text{TH-SUVP}}$	SUVP Threshold	–	0.58	0.6	0.62	V
$t_{\text{BLANK-SUVP}}$	SUVP Blank Time After Startup	–	20	25	30	ms
$t_{\text{SAMPLE}}$	Sample Delay Time(Note 8)	–	–	2	–	$\mu\text{s}$
<b>LDO Section (VCC_IN Pin/VCC Pin)</b>						
$V_{CC}$	LDO Regulated Voltage (Power Supply Voltage)	$V_{CC}$ open, $V_{CC\_IN} = 10\text{V}$	9	9.8	–	V
		$V_{CC}$ open, $V_{CC\_IN} = 40\text{V}$	19	20	21	V
$I_{\text{LDO}}$	Operating Current	$V_{CC} = 12\text{V}$ , $V_{CC\_IN} = 40\text{V}$	5	6	7	mA
<b>Protection Section (CTRL Pin)</b>						
$I_{\text{CTRL-SOURCE}}$	Source Current	–	-110	-100	-90	$\mu\text{A}$
$V_{\text{TH-CTRL-L}}$	Low Threshold	–	0.96	1	1.04	V
$V_{\text{TH-CTRL-H}}$	High Threshold	–	2.85	3	3.15	V
$V_{\text{CTRL-CLP}}$	Clamp Voltage (Note 7)	$I_{\text{CTRL}} = -2\text{mA}$	4.1	4.4	4.7	V
$t_{\text{DELAY-HICC}}$	Delay of Hiccup Protection (Note 8)	SUVP, SOVP, Line OVP, VCC OVP,FOCP,SSCP, CTRL Pin Protection	–	7	–	Cycles
<b>Internal OTP Section</b>						
OTP	OTP Threshold	–	–	+150	–	$^\circ\text{C}$
$T_{\text{HYS}}$	OTP Recovery Hysteresis	–	–	+25	–	$^\circ\text{C}$

- Notes:
6. Cycle-by-Cycle limit delay time contains OCP comparator delay time and driver delay time, Guaranteed by design.
  7. The sourcing current of CTRL pin must be limited below 5mA. Otherwise it may cause permanent damage to the device.
  8. Guaranteed by design.

**Performance Characteristics**

NEW PRODUCT

**Startup Voltage vs. Ambient Temperature**

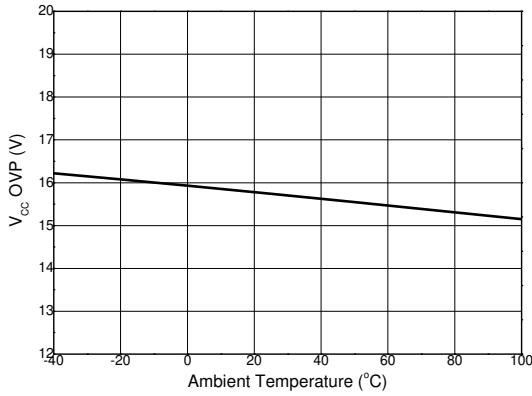

**Shutdown Voltage vs. Ambient Temperature**

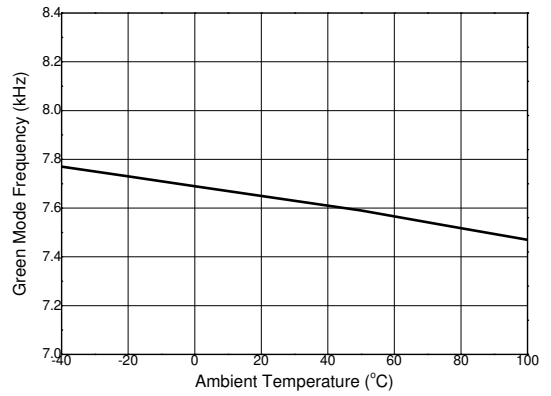

**Oscillation frequency vs. Ambient Temperature**

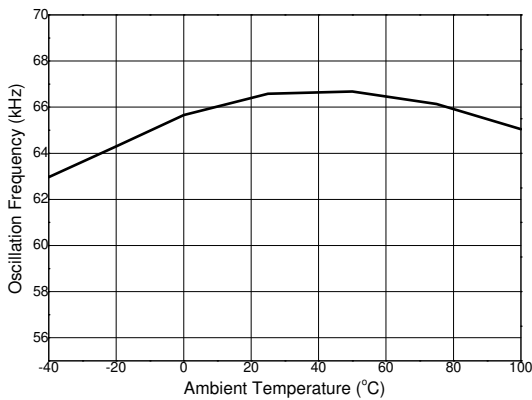

**FB Pin Input Impedance vs. Ambient Temperature**

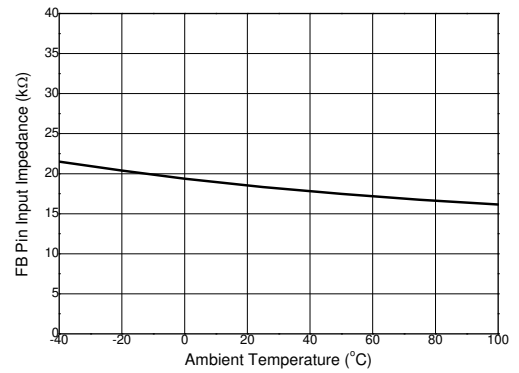

**V<sub>BURST</sub> vs. Ambient Temperature**

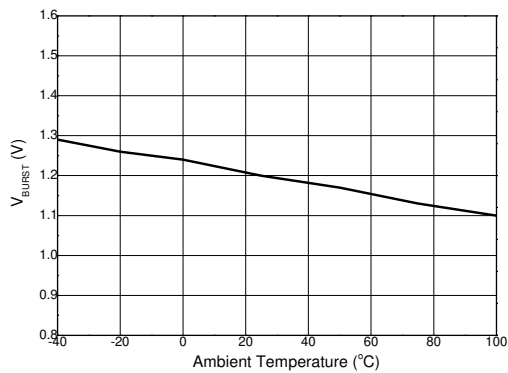

**V<sub>BR-IN</sub> vs. Ambient Temperature**

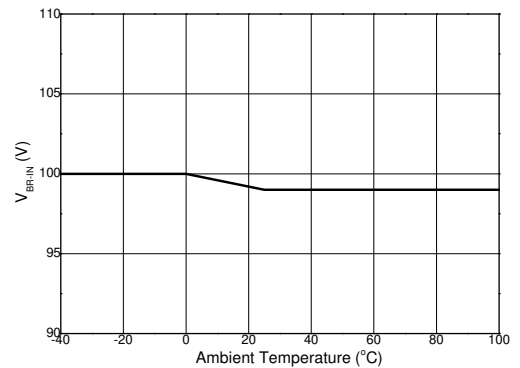



**Performance Characteristics (Cont.)**

**V<sub>BR-OUT</sub> vs. Ambient Temperature**

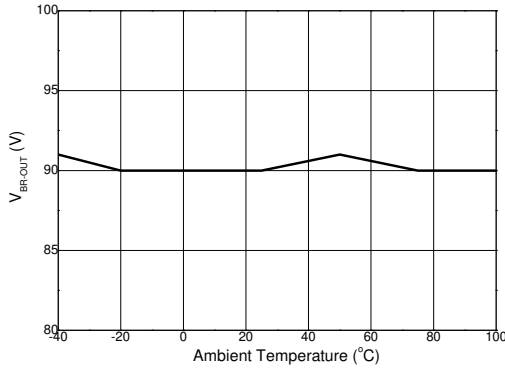

**Green Mode Frequency vs. Ambient Temperature**

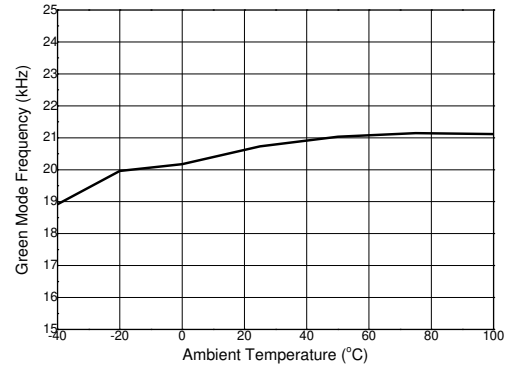

NEW PRODUCT

**Operation Description**

**PWM Operation Principle**

Figure 1 describes how the AP3108L and AP4320 work together to achieve constant voltage (CV), constant current (CC) and primary CC control. At secondary side, the sensed output voltage or output current signals are compared with the corresponding reference V<sub>REF\_CV</sub> and V<sub>REF\_CC</sub> in AP4320. The inner CV and CC amplifier combine with an external compensation network to generate an amplified error signal and transfer to the primary side FB pin through the opto-coupler. It's noted that only one amplifier works at one moment between CV and CC control. The scaled FB voltage comparing with the SENSE voltage after slope compensation will turn off primary switch and determine the duty cycle.

Usually, secondary CC and CV provide a good enough static state performance for output voltage and current regulation under all load and line conditions. The primary CC control only occurs at transient state, like start-up and output short condition. The primary CC control can provide moderate over current limit to reduce the device stress and output current value in output short condition. In primary CC control, the product of V<sub>C<sub>SM</sub></sub> sampled from SENSE Pin and  $\frac{t_{ONS}}{t}$  sampled from DEM Pin will compare with a primary CC reference of V<sub>REF</sub> and get a primary switch duty cycle, which will determine a real-time constant output current.

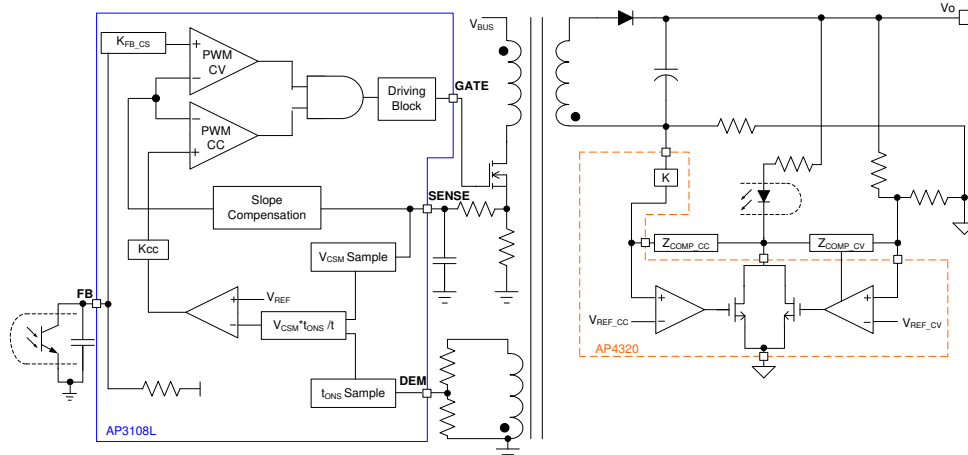

**Figure 1**

**Switching Frequency Control Strategy**

The AP3108L works in fixed frequency (65kHz) under heavy load, and decreases the switching frequency to improve the efficiency at light load and middle load through green mode. In green mode, the switching frequency is a function of V<sub>FB</sub> and the relationship is shown as Figure 2. If the V<sub>FB</sub> is lower than V<sub>TH-GREEN</sub>-0.2V, the switching frequency is fixed at 22kHz to avoid audible noise.

Burst mode is a traditional method used to reduce the standby power at no load and extremely light load. In burst mode, the controller will stop outputting switching pulses. As shown in Figure 3, when V<sub>FB</sub> drops below V<sub>BURST</sub> because of the light load, the system will enter burst mode and there is no more power transferred to the output, causing output voltage to decrease and V<sub>FB</sub> to recover to V<sub>BURST</sub> +110mV. Then, the system will recover and begin outputting switching pulses again, causing the output voltage to rise and V<sub>FB</sub> to drop again, which will start a new cycle.

Operation Description (Cont.)

NEW PRODUCT

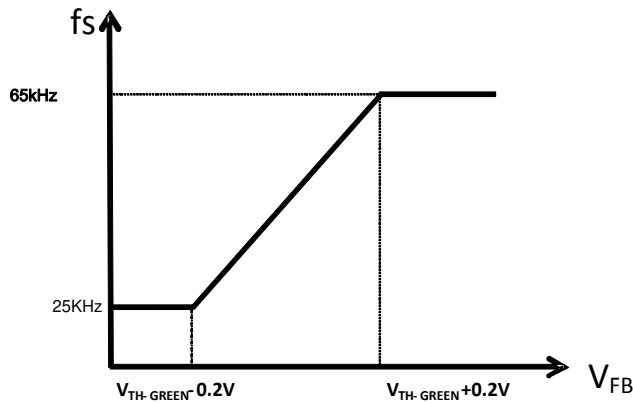

Figure 2

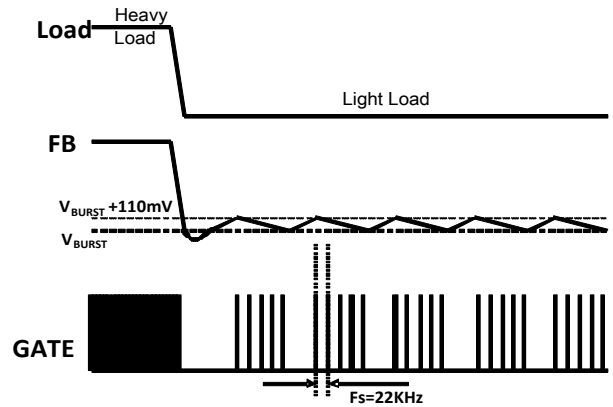

Figure 3

**Maximum output current limit (primary CC control)**

The traditional primary cycle-by-cycle peak current limit method works well for overload protection situation, but the output short current (peak value) is still too high, which will result in a higher safety risk. In order to reduce output short current (peak value) and keep normal startup performance, the AP3108L creates a new primary current control method to get a constant output current limit, the method is known as primary constant current (CC) control. The output current both for CCM and DCM can be both described as:

$$I_O = \frac{V_{CSM}}{R_{CS}} * \frac{N_P}{N_S} * \frac{t_{ONS}}{t}$$

Where  $R_{CS}$  is the primary current sense resistor,  $V_{CSM}$  is the middle voltage of the current sense voltage across  $R_{CS}$ ,  $N_P$  is the primary winding turns,  $N_S$  is the secondary winding turns,  $t_{ONS}$  is the conduction time of secondary rectifier,  $t$  is the switching period of the system. In primary CC control mode, to get a constant output current, the product of  $V_{CSM}$  and  $\frac{t_{ONS}}{t}$  is kept as a constant value equaling to  $V_{REF}$ , so the output current equation can be rearranged as:

$$I_O = \frac{V_{REF}}{R_{CS}} * \frac{N_P}{N_S} * K_{CC}$$

Where  $K_{CC}$  is 1/12, an inner parameter used to balance the relationship between the current sense voltage and the primary CC control signal. For a specific power design, output current can be set by adjusting the value of  $R_{CS}$ . The primary CC control module only monitors the product of  $V_{CSM}$  and  $\frac{t_{ONS}}{t}$ . A peak current limitation of primary side is also set by  $V_{CS-MAX}$  to avoid transformer saturation under some transient conditions.

The AP3108L samples the middle current of the primary side to calculate the output current. The detecting time takes the GATE signal as the reference shown as Figure 4, at the half-on time of the GATE, the AP3108L will record the  $V_{CS}$  value as  $V_{CSM}$ . In the actual system, the primary current will be greatly impacted by the turn-off delay time which mainly contains MOSFET charging time, resulting in an error between the detected  $V_{CSM}$  and the actual  $V_{CSM}$ . The error varies depending on line voltage, generally increasing with the line voltage. To get a precise  $V_{CSM}$  and keep the output current constant when primary CC module actives, the AP3108L adopts a line compensation technology and the control block is illustrated in Figure 5. The current flowing through R1 when the primary MOSFET is on reflects the line voltage. Scale down the current and multiply it with  $R_C$  and  $R_F$ , then a compensation signal is formed. The external resistor R1 can be used to adjust the compensation according to different delay time. The calculating formula is:

$$R1 = \frac{2 * L_P}{t_D} * \frac{N_A}{N_P} * \frac{(R_C + R_F)}{R_{CS}} * \frac{1}{m}$$

Where  $L_P$  is the inductance of the transformer,  $t_D$  is the turn-off delay time,  $N_A$  is the auxiliary winding turns,  $N_P$  is the primary winding turns,  $R_C$  is the inner compensation resistor which is 1.2k $\Omega$ ,  $R_F$  is the filter resistor of SENSE pin,  $R_{CS}$  is the primary-current sense resistor,  $m$  is the inner proportional parameter which is 24.

**Operation Description** (Cont.)

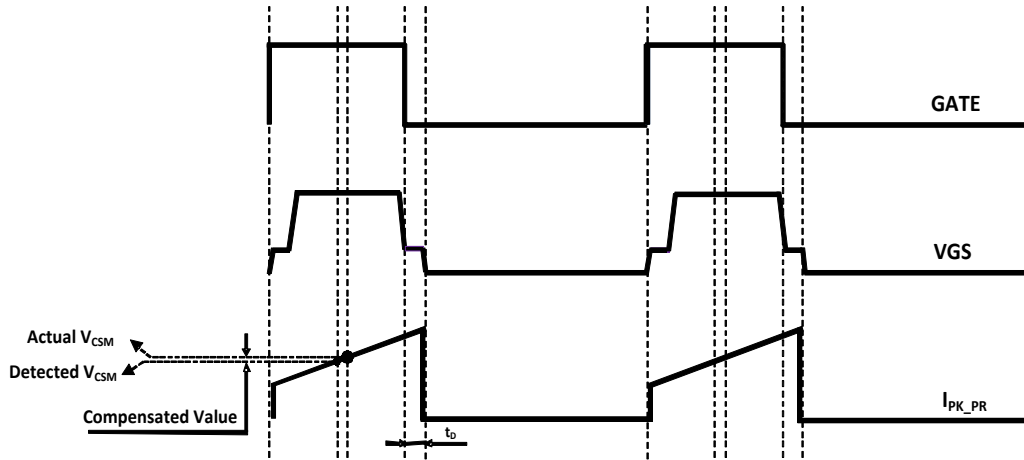

Figure 4

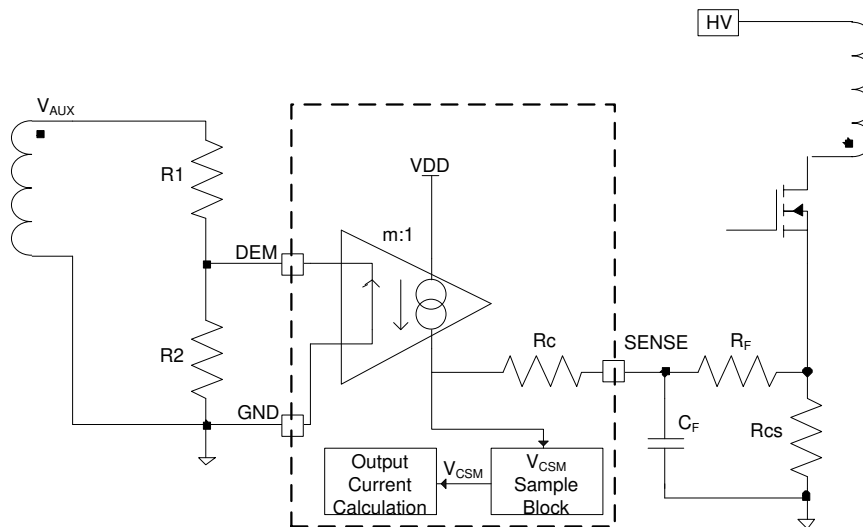

Figure 5

**HV Start-Up Circuit**

A built-in HV Start-Up circuit in AP3108L can help to simplify the power system design for ultra low standby application. For AP3108L, there are two HV Start-Up charging current: the  $I_{CHARGE-L}$  when  $V_{CC}$  is lower than 6V and the  $I_{CHARGE-H}$  when the  $V_{CC}$  voltage rises above 6V, which can prevent the IC from overheat when  $V_{CC}$  short- to-GND fault happens. The HV Start-Up circuit will stop working and has no additional power dissipation when  $V_{CC}$  voltage reaches the  $V_{ST}$ , at which the AP3108L starts working and will supply energy to  $V_{CC}$  from auxiliary winding.

However, the charging process described above is only for the normal system startup condition. Once some system faults occur and the protection process is triggered, AP3108L will shut down and  $V_{CC}$  voltage will begin to decrease. The HV Start-Up circuit starts working again when  $V_{CC}$  voltage decreases below  $V_{CC-UVLO}$ , and charges the  $V_{CC}$  capacitor with current of  $I_{CHARGE-FAULT}$ . This special design can reduce hugely the input power dissipation when system fault happens, especially for output short condition. The HV Start-Up circuit working processes is illustrated in Figure 6.

**Operation Description** (Cont.)

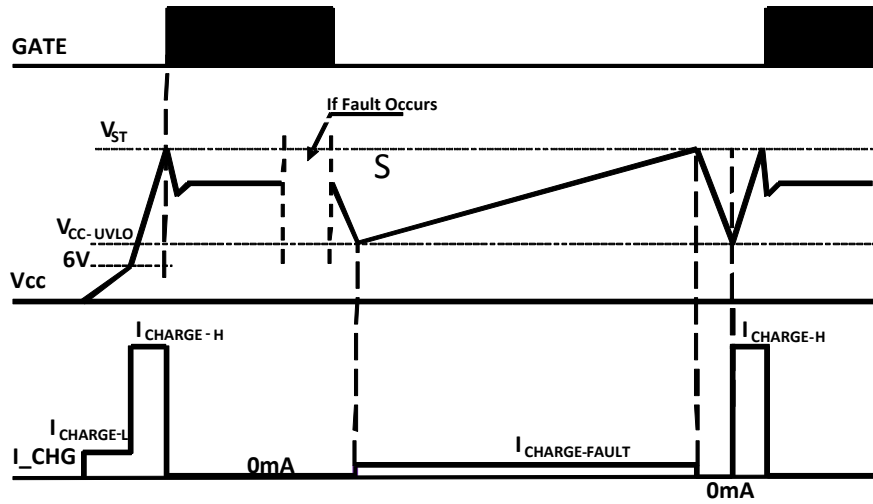

Figure 6

**X-CAP Discharge Function**

For the higher power application, to attenuate the differential mode noise, an X-CAP is usually used before the rectifier bridge, and there are paralleled resistors to discharge the X-CAP for safety consideration when the AC line is off. The paralleled resistors have large power dissipation and will increase the standby power. The AP3108L integrates an X-CAP discharge function to replace discharge resistors and decreases the standby power.

This function contains two processes; the first process detects the condition of the AC line through HV Pin, this detected voltage is named as V<sub>b</sub>. When the system is plugged in, an inner timer of 40ms within the AP3108L begins to work, meanwhile, a phase-drifted and filtered signal V<sub>c</sub> is generated based on V<sub>b</sub>, compare V<sub>b</sub> with V<sub>c</sub>, as shown in Figure 7.

Whenever signal V<sub>c</sub> crosses over with signal V<sub>b</sub>, the inner 40ms timer will be reset which represents the AC line is on. If the system is disconnected from AC line, the cross-over signal of V<sub>c</sub> and V<sub>b</sub> will disappear and the 40ms timer will continue to count until it reaches 40ms, at this moment, the second process, discharge process, will come into effect and a 1.7mA discharge current will flow through HV pin to GND lasting for 40ms. After the AC line is off, the first process and the second process will act alternately until the HV Pin voltage is discharged below 10V even when the V<sub>CC</sub> voltage is lower than V<sub>CC-UVLO</sub>.

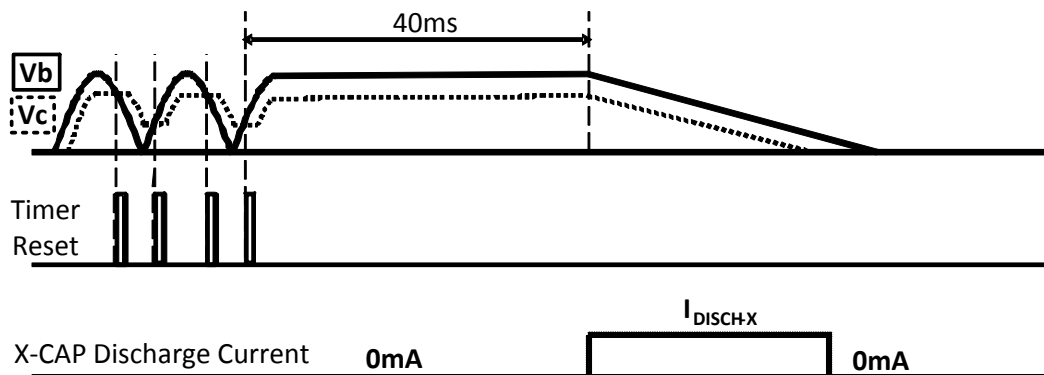

Figure 7

**Built-In Slope Compensation**

It is well known that a continuous current mode SMPS may become unstable when the duty cycle exceeds 50%. The built-in slope compensation in the AP3108L can keep the system stable.

**Built-In V<sub>CC</sub> LDO**

The AP3108L integrates a V<sub>CC</sub> LDO circuitry, the LDO regulates the wide range V<sub>CC-IN</sub> which is rectified from auxiliary winding to an acceptable value. It makes the AP3108L a good choice in wide range output voltage application.

**Operation Description** (Cont.)

**Brown In/Out Protection**

To avoid potential high-current stress at low line voltage, the AP3108L introduces a reliable brownout protection. The AC line voltage is detected through HV Pin, A pair of high-voltage diodes are connected to the AC line which will rectify the AC input voltage to a double-frequency positive voltage referring to GND, a ~20kΩ resistor is recommended to be added to improve the surge immunity. When the voltage across HV pin is higher than  $V_{BR-IN}$  for about 100μs of  $t_{BR-IN}$  and  $V_{CC}$  reaches  $V_{ST}$ , the GATE pin will output drive signals and the system starts to work. If the HV pin voltage falls below  $V_{BR-OUT}$  and lasts for 50ms of  $t_{BR-OUT}$ , the GATE pin will turn off and the system will shut down until the line voltage rises over its brown-in voltage again.

**SOVP/SUVP Protection**

The AP3108L provides output OVP and UVP protection function. The auxiliary winding voltage during secondary rectifier conducting period reflects the output voltage. A voltage divide network is connected to the auxiliary winding and DEM Pin, the DEM Pin will detect the equivalent output voltage with a delay of  $t_{SAMPLE}$  from the falling edge of GATE driver signal, as shown in Figure 8. The detected voltage will be compared to the SOVP and SUVP threshold voltage  $V_{TH-SOVP}$  and  $V_{TH-SUVP}$ . If the SOVP or SUVP threshold is reached continuously by 7 switching cycles, the SOVP or SUVP protection will be triggered, the AP3108L will shut down and the system will restart when the  $V_{CC}$  voltage falls below the UVLO voltage.

To prevent from false-trigger of SUVP during start up process, a blank time of  $t_{BLANK-SUVP}$  is set during which the SUVP protection function is ignored.

**Externally Triggered Protection**

The AP3108L reserves flexible protection mode for power design. The CTRL Pin can achieve external programmable protection. A high threshold of  $V_{TH-CTRL-H}$  is set for any over voltage protection, the CTRL Pin voltage will be sampled with a delay of  $t_{SAMPLE}$  from the falling edge of GATE and compared to  $V_{TH-CTRL-H}$ , if the sampled voltage is higher than the threshold for 7 switching cycles, the CTRL-High protection will be triggered. A low threshold of  $V_{TH-CTRL-L}$  is usually used for external over temperature protection. To realize the external OTP, a proper value NTC should be connected from the CTRL Pin to the ground. During the primary switch turning-on period, an inner current of 100μA flows through the NTC from the CTRL pin. The voltage of the CTRL Pin changes along with the resistance of NTC. The AP3108L will detect the voltage of CTRL Pin ahead of the falling edge of GATE with about 100ns. If the detected voltage is lower than the  $V_{TH-CTRL-L}$  for 32ms duration at least, the CTRL-Low protection will be triggered. Whenever the protection is triggered, the system will stop the output drive signal and will restart after the  $V_{CC}$  voltage falling below the UVLO voltage. The CTRL-High and CTRL-Low protection sample time is illustrated as Figure 8.

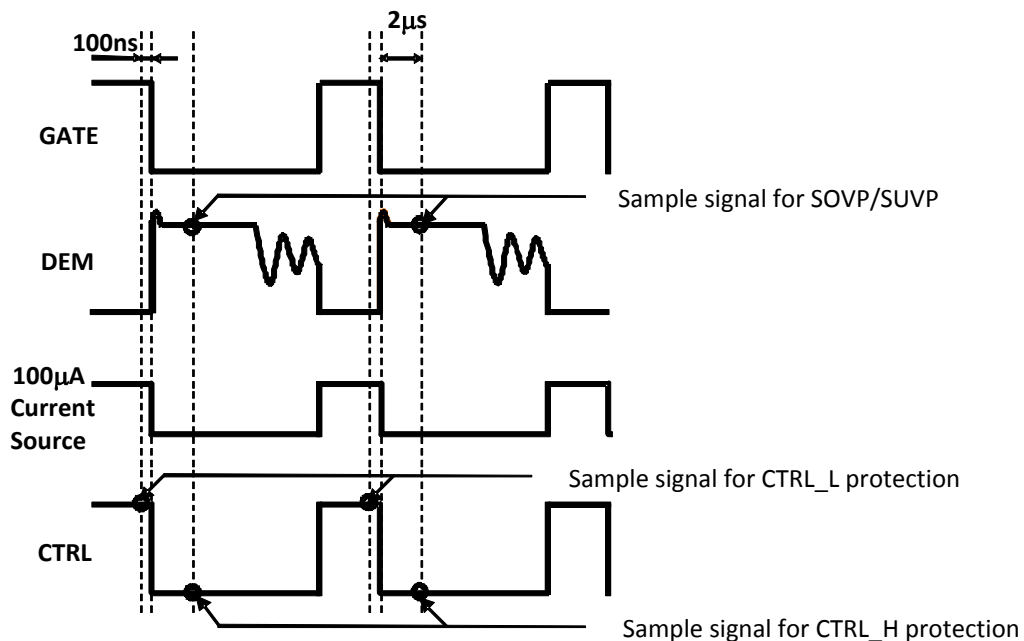

Figure 8

NEW PRODUCT

**Operation Description** (Cont.)

**System Protection**

**LOVP, FOCV, SSCP, VCC OVP, OTP,**

The AP3108L provides versatile protection to ensure the reliability of the power system. LOVP achieves line voltage overvoltage protection, if the detected AC line voltage is higher than  $V_{LOVP}$  for 7 switching cycles, the LOVP protection will be triggered. FOCV protection is an ultra-fast short-current protection which is helpful to avoid catastrophic damage of the system when the secondary rectifier is short. The primary peak current will be monitored by SENSE pin through a primary sense resistor, whenever the sampled voltage reaches the threshold of  $V_{TH-FOCV}$  for 7 switching cycles continuously, the FOCV protection will be active to shut down the switching pulse. SSCP might be triggered at ultra-low line voltage condition or other failure condition that short the SENSE pin to ground. The SSCP module senses the voltage across the primary sense resistor with a delay of  $4\mu s$  after the rising edge of primary GATE signal, this sensed signal is compared with  $V_{TH-SSCP}$ . If it is lower than  $V_{TH-SSCP}$  for 7 switching cycles, the SSCP protection will be triggered and the drive signal will be disabled. All these protections described above will restart the system when the  $V_{CC}$  voltage falls below UVLO. Although the external OTP can be easily implemented through CTRL pin, the AP3108L still reserves the inner OTP with a hysteresis for any necessary use.

**V<sub>CC</sub> Maintain Mode**

During light-load or transient-load condition,  $V_{FB}$  will drop and be lower than 1.2V, thus the PWM drive signal will be stopped, and there is no more new energy transferring to the output. Therefore, the IC supply voltage may reduce to the UVLO threshold voltage and system may enter the unexpected restart mode. To avoid this, the AP3108L holds a so-called  $V_{CC}$  maintain mode which can supply energy to  $V_{CC}$ .

When  $V_{CC}$  decreases to a setting threshold as  $V_M$ , the  $V_{CC}$  maintain mode will be awaked and a charging current of  $I_{CHARGE-H}$  will flow to the  $V_{CC}$  Pin. With  $V_{CC}$  maintain mode, the  $V_{CC}$  is not easy to touch the shutdown threshold during the startup process and transient load condition. This will also simplify the system design. The minimum  $V_{CC}$  voltage is suggested to be designed a little higher than  $V_{CC}$  maintain threshold thus can achieve the best balance between the power loss and step load performance.

**Leading-Edge Blanking Time**

A narrow spike on the leading edge of the current waveform can usually be observed when the power MOSFET is turned on. A 250ns leading-edge blank is built-in to prevent the false-trigger caused by the turn-on spike. During this period, the current limit comparator and the PWM comparator are disabled and the gate driver cannot be switched off.

At the time of turning-off the MOSFET, a negative undershoot (maybe larger than -0.3V) can occur on the SENSE pin. So it is strongly recommended to add a small RC filter or at least connect a resistor "R" on this pin to protect the IC (Shown as Figure 9).

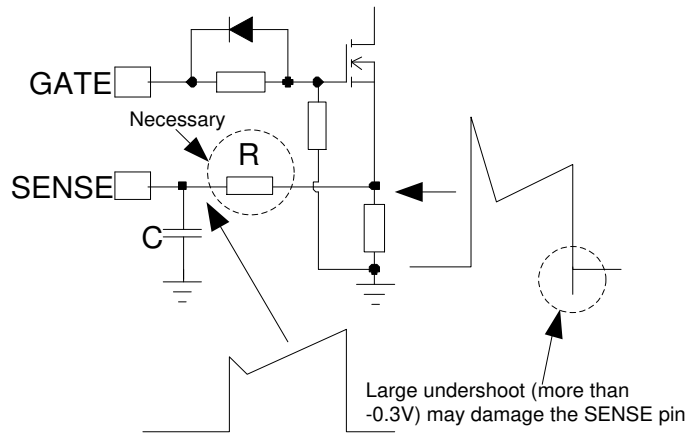

**Figure 9**

NEW PRODUCT

**Ordering Information**

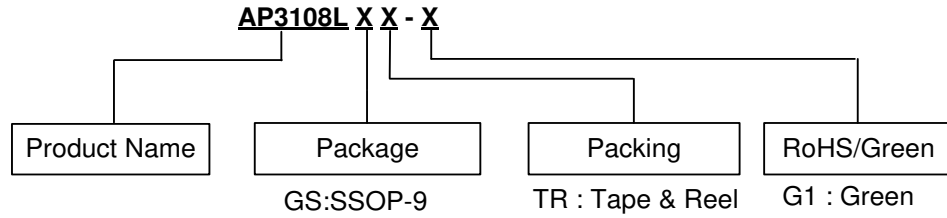

Package	Temperature Range	Part Number	Marking ID	Packing
SSOP-9 (Type CJ)	-40°C to +85°C	AP3108LGSTR-G1	3108LGS-G1	4,000/Tape & Reel

**Marking Information**

(Top View)

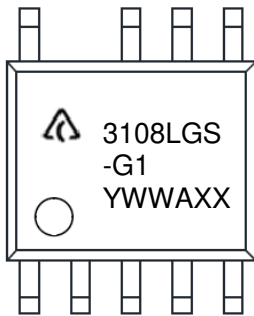

First and Second Lines: Logo and Marking ID  
 Third Line: Date Code  
 Y: Year  
 WW: Work Week of Molding  
 A: Assembly House Code  
 XX: 7<sup>th</sup> and 8<sup>th</sup> Digits of Batch No.

NEW PRODUCT

**Package Outline Dimensions** (All dimensions in mm.)

Please see <http://www.diodes.com/package-outlines.html> for the latest version.

(1) Package Type: SSOP-9 (Type CJ)

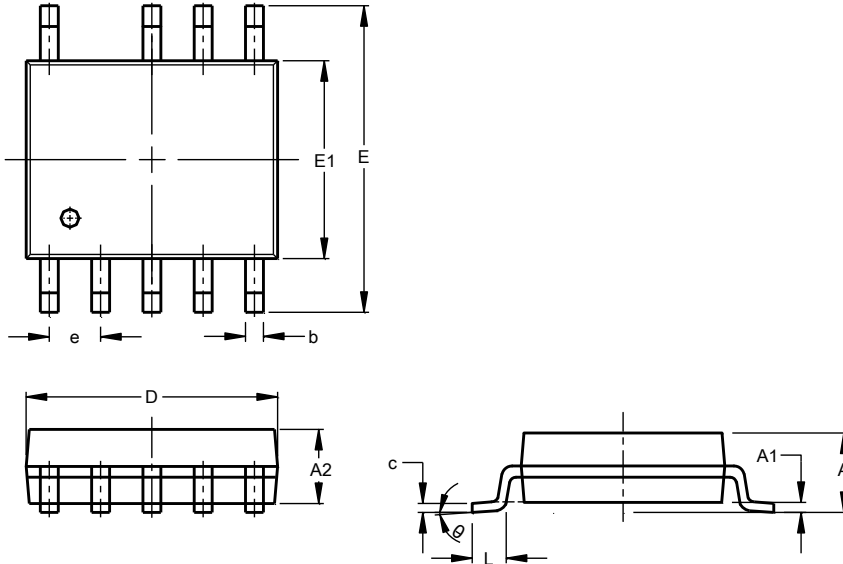

SSOP-9 (Type CJ)			
Dim	Min	Max	Typ
A	1.35	1.75	--
A1	0.10	0.25	--
A2	1.350	1.550	--
b	0.270	0.430	--
c	0.170	0.258	--
D	4.70	5.10	--
E	5.80	6.20	--
E1	3.80	4.00	--
e	--	--	1.00
L	0.40	1.27	--
θ	0°	8°	--
All Dimensions in mm			

**Suggested Pad Layout**

Please see <http://www.diodes.com/package-outlines.html> for the latest version.

(1) Package Type: SSOP-9 (Type CJ)

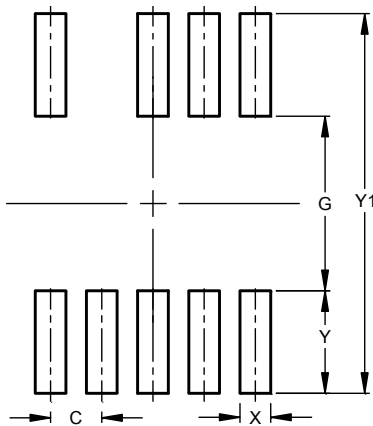

Dimensions	Value (in mm)
C	1.00
G	3.40
X	0.60
Y	2.00
Y1	7.40

NEW PRODUCT



**IMPORTANT NOTICE**

DIODES INCORPORATED MAKES NO WARRANTY OF ANY KIND, EXPRESS OR IMPLIED, WITH REGARDS TO THIS DOCUMENT, INCLUDING, BUT NOT LIMITED TO, THE IMPLIED WARRANTIES OF MERCHANTABILITY AND FITNESS FOR A PARTICULAR PURPOSE (AND THEIR EQUIVALENTS UNDER THE LAWS OF ANY JURISDICTION).

Diodes Incorporated and its subsidiaries reserve the right to make modifications, enhancements, improvements, corrections or other changes without further notice to this document and any product described herein. Diodes Incorporated does not assume any liability arising out of the application or use of this document or any product described herein; neither does Diodes Incorporated convey any license under its patent or trademark rights, nor the rights of others. Any Customer or user of this document or products described herein in such applications shall assume all risks of such use and will agree to hold Diodes Incorporated and all the companies whose products are represented on Diodes Incorporated website, harmless against all damages.

Diodes Incorporated does not warrant or accept any liability whatsoever in respect of any products purchased through unauthorized sales channel. Should Customers purchase or use Diodes Incorporated products for any unintended or unauthorized application, Customers shall indemnify and hold Diodes Incorporated and its representatives harmless against all claims, damages, expenses, and attorney fees arising out of, directly or indirectly, any claim of personal injury or death associated with such unintended or unauthorized application.

Products described herein may be covered by one or more United States, international or foreign patents pending. Product names and markings noted herein may also be covered by one or more United States, international or foreign trademarks.

This document is written in English but may be translated into multiple languages for reference. Only the English version of this document is the final and determinative format released by Diodes Incorporated.

**LIFE SUPPORT**

Diodes Incorporated products are specifically not authorized for use as critical components in life support devices or systems without the express written approval of the Chief Executive Officer of Diodes Incorporated. As used herein:

A. Life support devices or systems are devices or systems which:

1. are intended to implant into the body, or
2. support or sustain life and whose failure to perform when properly used in accordance with instructions for use provided in the labeling can be reasonably expected to result in significant injury to the user.

B. A critical component is any component in a life support device or system whose failure to perform can be reasonably expected to cause the failure of the life support device or to affect its safety or effectiveness.

Customers represent that they have all necessary expertise in the safety and regulatory ramifications of their life support devices or systems, and acknowledge and agree that they are solely responsible for all legal, regulatory and safety-related requirements concerning their products and any use of Diodes Incorporated products in such safety-critical, life support devices or systems, notwithstanding any devices- or systems-related information or support that may be provided by Diodes Incorporated. Further, Customers must fully indemnify Diodes Incorporated and its representatives against any damages arising out of the use of Diodes Incorporated products in such safety-critical, life support devices or systems.

Copyright © 2017, Diodes Incorporated

[www.diodes.com](http://www.diodes.com)