



Chipsmall Limited consists of a professional team with an average of over 10 year of expertise in the distribution of electronic components. Based in Hongkong, we have already established firm and mutual-benefit business relationships with customers from,Europe,America and south Asia,supplying obsolete and hard-to-find components to meet their specific needs.

With the principle of “Quality Parts,Customers Priority,Honest Operation,and Considerate Service”,our business mainly focus on the distribution of electronic components. Line cards we deal with include Microchip,ALPS,ROHM,Xilinx,Pulse,ON,Everlight and Freescale. Main products comprise IC,Modules,Potentiometer,IC Socket,Relay,Connector.Our parts cover such applications as commercial,industrial, and automotives areas.

We are looking forward to setting up business relationship with you and hope to provide you with the best service and solution. Let us make a better world for our industry!



## Contact us

Tel: +86-755-8981 8866 Fax: +86-755-8427 6832

Email & Skype: info@chipsmall.com Web: www.chipsmall.com

Address: A1208, Overseas Decoration Building, #122 Zhenhua RD., Futian, Shenzhen, China



**SIXTEEN-CHANNEL, 75mA CURRENT SINK WITH CURRENT MATCH AP3616****General Description**

The AP3616 is an sixteen-channel constant current sink with current match used for LED driver. It uses an external resistor to set the current for sixteen LED strings with an accuracy of  $\pm 1.5\%$ . The full scale LED current can be adjusted from 20mA to 75mA for each channel. The LED lightness can be adjusted by PWM dimming function.

The device can keep working normally without any damage when LEDs are short or open. It features under voltage lockout protection and over temperature protection.

The AP3616 has three interface terminals (FB, SYN and FBX pins). The FB and SYN pins allow the device to work with a DC/DC converter to drive LED arrays for good performance. And the FBX pin enables the device to be connected in parallel.

The AP3616 is available in SOIC-28 and HSOP-28 packages.

**Features**

- Input Voltage Range: 4.2V to 27V
- Maximum Output Current: Typical 1.2A (75mA per Channel)
- Current Match Accuracy (Typical):  $\pm 1.5\%$
- PWM / Linear Dimming Control
- Open LED Self-check and Protection
- Flexible Short LED Protection
- Under Voltage Lockout Protection
- Over Temperature Protection
- FBX and SYN Pins Enable Parallel Application
- Over Voltage Protection

**Applications**

- LCD Display Modules
- LCD Monitor
- LCD TV

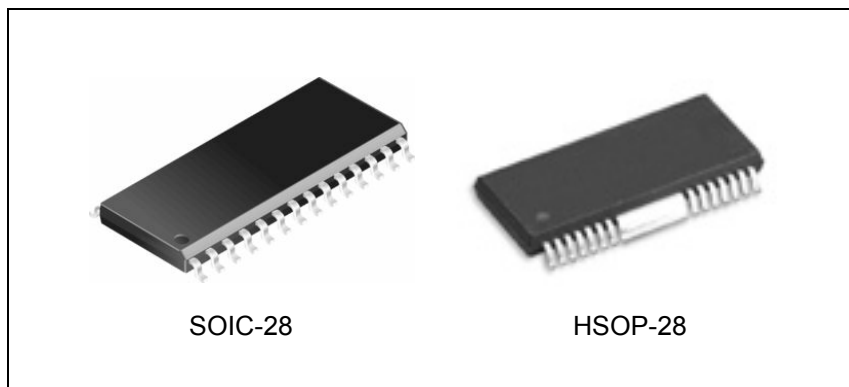

Figure 1. Package Types of AP3616

**SIXTEEN-CHANNEL, 75mA CURRENT SINK WITH CURRENT MATCH AP3616**

**Pin Configuration**

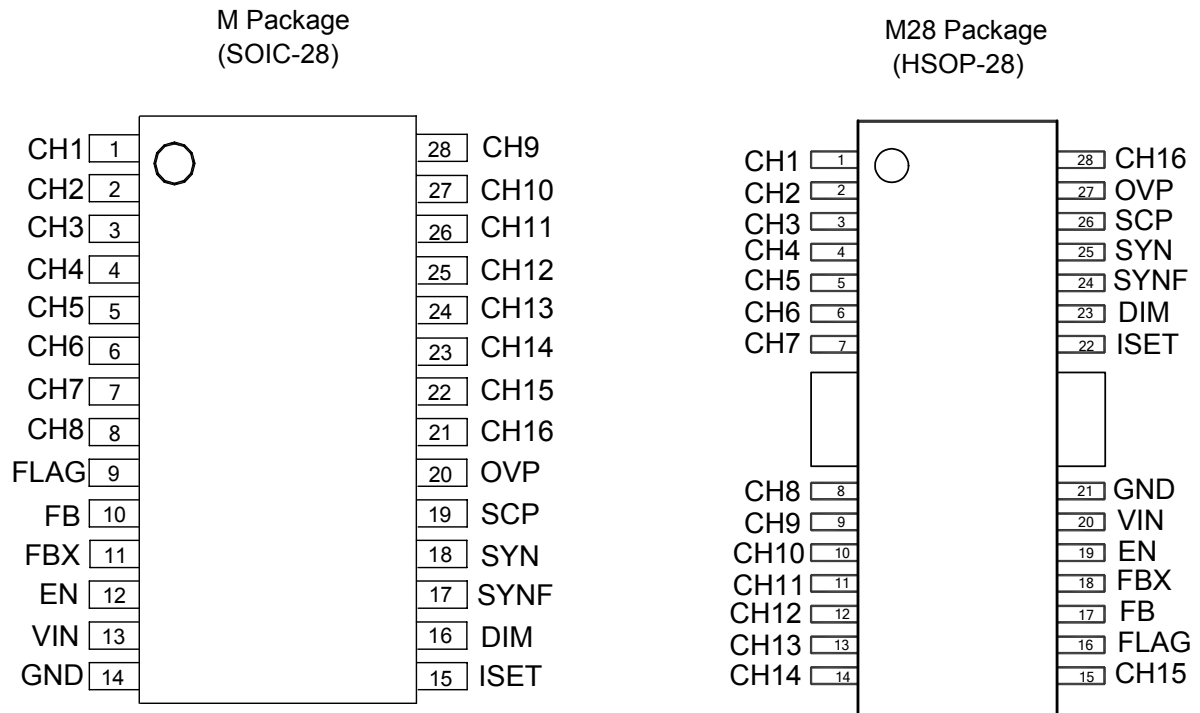

Figure 2. Pin Configuration of AP3616 (Top View)

**SIXTEEN-CHANNEL, 75mA CURRENT SINK WITH CURRENT MATCH AP3616****Pin Description**

Pin Number		Pin Name	Function
SOIC-28	HSOP-28		
1 to 8 28 to 21	1 to 8 9 to 15 & 28	CH1 to CH8 CH9 to CH16	White LED cathode connection pins. If not used, leave them unconnected
9	16	FLAG	Error flag pin. When LED load goes to error (short or open), the flag open drain output will close
10	17	FB	Feedback pin. This pin is an interface terminal, which samples the voltage of each channel, and outputs the lowest voltage of the string to DC/DC converter
11	18	FBX	This pin is an interface terminal. Connect it to FB pin can achieve parallel application. If not used, leave it unconnected
12	19	EN	Enable pin. Logic high enables the IC and logic low disables the IC
13	20	VIN	Input voltage pin
14	21	GND	Ground pin
15	22	ISET	LED current setting pin. An external resistor is connected to this pin. Current on each channel can be expressed by $I_{CHANNEL} = 1.194 * 1560 / R_{ISET}$
16	23	DIM	Dimming control pin. Adding a PWM signal or DC signal to this pin to control LED dimming. Connect it to high voltage level if not used
17	24	SYNF	Synchronous PWM frequency setting pin. A nF level of capacitor should be connected to this pin to set PWM frequency at about 80Hz to 25kHz
18	25	SYN	PWM dimming synchronous pin, this pin outputs DC transformed PWM signal to synchronize parallel AP3616 and power converter, if not used, leave it unconnected
19	26	SCP	LED short trigger voltage setting pin. This pin is used to set the LED short circuit protection voltage level
20	27	OVP	This pin is used to trigger OVP condition. OVP triggering voltage should be lower than the OVP voltage of its cascade chip, such as AP3039A in Figure 19

**SIXTEEN-CHANNEL, 75mA CURRENT SINK WITH CURRENT MATCH AP3616**

**Functional Block Diagram**

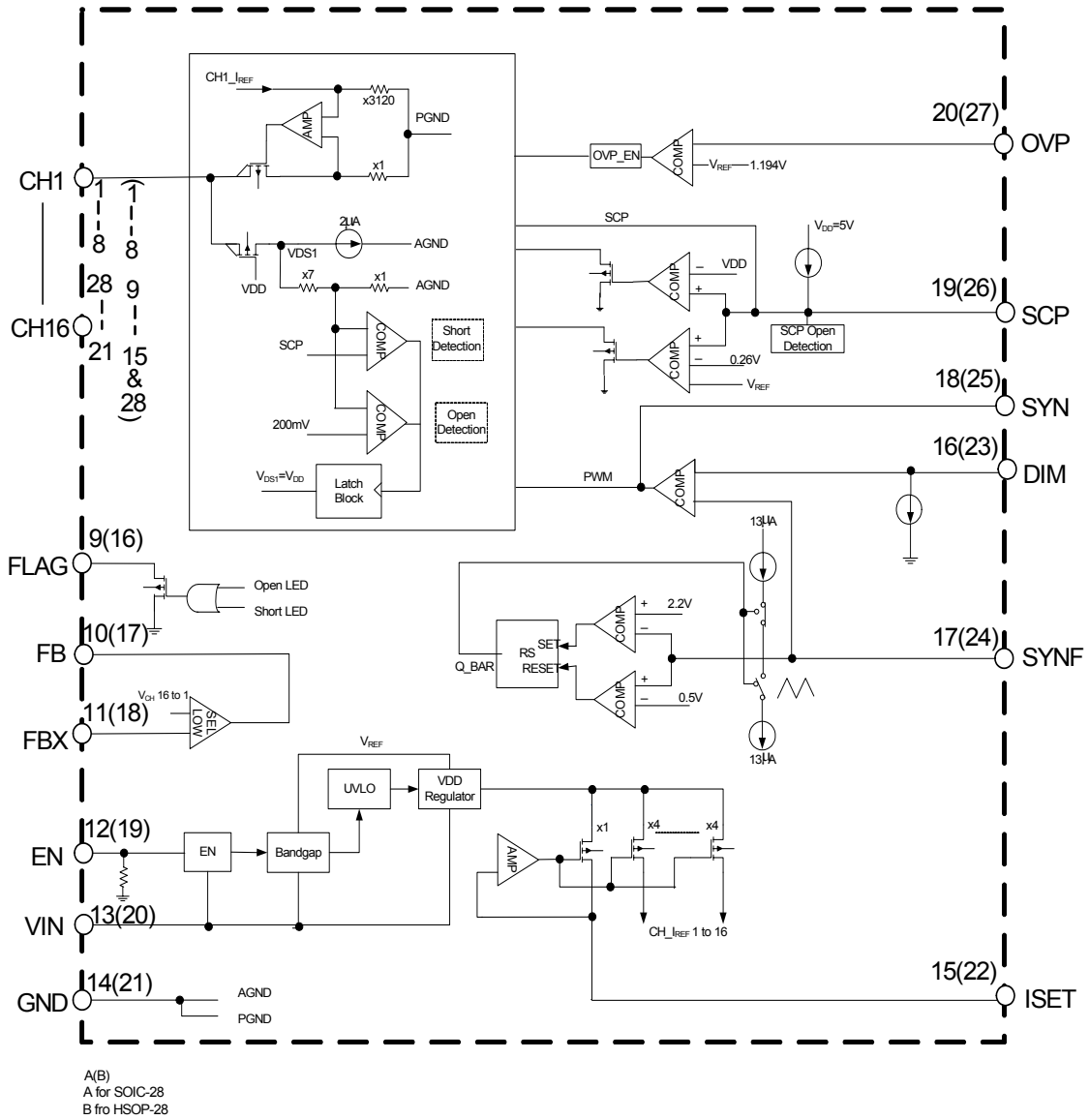
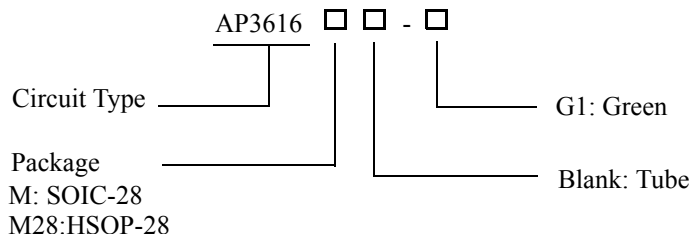

Figure 3. Functional Block Diagram of AP3616



**SIXTEEN-CHANNEL, 75mA CURRENT SINK WITH CURRENT MATCH AP3616**

**Ordering Information**



Package	Temperature Range	Part Number	Marking ID	Packing Type
SOIC-28	-40 to 85°C	AP3616M-G1	AP3616M-G1	Tube
HSOP-28		AP3616M28-G1	AP3616M28-G1	Tube

BCD Semiconductor's Pb-free products, as designated with "G1" suffix in the part number, are RoHS compliant and green.

**Absolute Maximum Ratings (Note 1)**

Parameter	Symbol	Value	Unit
Input Voltage	$V_{IN}$	30	V
FLAG Pin Voltage	$V_{FLAG}$	30	V
EN Pin Voltage	$V_{EN}$	30	V
Voltage on Each Channel	$V_{CHX}$	-0.3 to 60	V
Voltage on Other Seperate Pins		-0.3 to 6	V
Thermal Resistance (Junction to Ambient, No Heat Sink)	SOIC-28	$\theta_{JA}$	72 °C/W
	HSOP-28		59 °C/W
Operating Junction Temperature	$T_J$	150	°C
Lead Temperature (Soldering, 10sec)	$T_{STG}$	-65 to 150	°C
ESD (Human Body Model)		2000	V
ESD (Machine Model)		200	V

Note 1: Stresses greater than those listed under "Absolute Maximum Ratings" may cause permanent damage to the device. These are stress ratings only, and functional operation of the device at these or any other conditions beyond those indicated under "Recommended Operating Conditions" is not implied. Exposure to "Absolute Maximum Ratings" for extended periods may affect device reliability.

**SIXTEEN-CHANNEL, 75mA CURRENT SINK WITH CURRENT MATCH AP3616****Recommended Operating Conditions**

Parameter	Symbol	Min	Max	Unit	
Input Voltage	$V_{CC}$	4.2	27	V	
Recommended PWM Dimming Frequency	$f_{PWM}$	0.08	25	kHz	
Full Scale Setting Current per Channel	$V_{CHX}=0.5V$	$I_{CHX}$	20	40	mA
	$V_{CHX}=0.8V$		20	60	
	$V_{CHX}=1.2V$		20	75	
Operating Temperature Range	$T_A$	-40	85	°C	

**Electrical Characteristics**

$V_{IN}=24V$ ,  $V_{EN}=5V$ ,  $T_A=25^{\circ}C$ , unless otherwise specified. **Boldface type** apply over the full operating temperature range ( $T_A=-40^{\circ}C$  to  $85^{\circ}C$ ).

Parameter	Symbol	Conditions	Min	Typ	Max	Unit
<b>VCC SECTION</b>						
Quiescent Current	$I_Q$	ISET, SYN and FB Pin Floating		2	4	mA
Shutdown Supply Current	$I_{STBY}$	$V_{EN}=0V$ , ISET, SYN and FB Pin Floating		0.1	1	$\mu A$
Under Voltage Lockout Threshold	$V_{UVLO}$	VIN Falling Edge	3.65	3.9	4.15	V
Under Voltage Lockout Hysteresis	$V_{UVLO\_HYS}$			300		mV
<b>CHANNEL SECTION</b>						
Maximum Output Current per Channel	$I_{CHX\_MAX}$	$V_{CHX}=0.8V$ , $R_{ISET}=0$	75			mA
Current Sink Saturation Voltage per Channel	$V_{CHX\_SAT}$	$I_{CHX}=60mA$			<b>0.6</b>	V
Current Matching Accuracy between Any Two Channels	$I_{CH\_MATCHING}$	$I_{CHX}=60mA$ , $V_{CH}=0.8V$			3	%
Output Current Load Regulation		$V_{CHX}=0.5V$ to $2.8V$			4	%
Output Current Line Regulation (Note 2)		$V_{CHX}=4.2V$ to $2.8V$			2	%/V

Note 2: Guaranteed by design (GBD).



**SIXTEEN-CHANNEL, 75mA CURRENT SINK WITH CURRENT MATCH AP3616**

**Electrical Characteristics (Continued)**

$V_{IN}=24V$ ,  $V_{EN}=5V$ ,  $T_A=25^{\circ}C$ , unless otherwise specified. **Boldface type** apply over the full operating temperature range ( $T_A=-40^{\circ}C$  to  $85^{\circ}C$ ).

Parameter	Symbol	Conditions	Min	Typ	Max	Unit
<b>DIMMING SECTION</b>						
PWM High Level Threshold Voltage	$V_{IH\_PWM}$		2.5			V
PWM Low Level Threshold Voltage	$V_{IL\_PWM}$				0.3	V
Linear Dimming Level	$V_{L\_DIM}$		0.5		2.2	V
<b>LED SHORT PROTECTION SECTION</b>						
SCP Current	$I_{SCP}$		10.5	12.5	14.5	$\mu A$
<b>CURRENT SINK SECTION</b>						
ISET Reference Voltage	$V_{ISET}$	$R_{ISET}=30k$ , CH1 to CH16 Floating	<b>1.170</b>	<b>1.194</b>	<b>1.218</b>	V
$I_{CHX}/I_{SET}$ Current Multiplication Ratio	k	$R_{ISET}=30k$ , $V_{CHX}=1V$		1615		
<b>ENABLE SECTION</b>						
EN Pin High Level Threshold	$V_{IH\_EN}$		2.0			V
EN Pin Low Level Threshold	$V_{IL\_EN}$				0.8	V
<b>OVP SECTION</b>						
Threshold Voltage	$V_{THRESHOLD}$		1.130	1.194	1.250	V
<b>FLAG SECTION</b>						
Saturation Voltage	$V_{SAT}$	$I_{SINK}=2mA$			0.3	V
<b>SYN SECTION</b>						
PWM Frequency	$f_{PWM}$		0.08		25	kHz
SYNF High Level Output Voltage	$V_{OUT\_H}$		2.4			V
SYNF Low Level Output Voltage	$V_{OUT\_L}$				0.4	V
<b>FB SECTION</b>						
Feedback Output Current	$I_{FB}$	$V_{FB}$ Drop to 97%	13	17		$\mu A$
<b>TOTAL DEVICE</b>						
Thermal Shutdown Temperature	$T_{OTSD}$	CHX Pin Left Floating		160		$^{\circ}C$
Thermal Shutdown Hysteresis	$T_{HYS}$			20		$^{\circ}C$





**SIXTEEN-CHANNEL, 75mA CURRENT SINK WITH CURRENT MATCH AP3616**

**Typical Performance Characteristics**

$V_{IN}=24V$ ,  $V_{EN}=5V$ ,  $R_{ISET}=30k\Omega$ ,  $T_A=25^\circ C$ , unless otherwise specified.

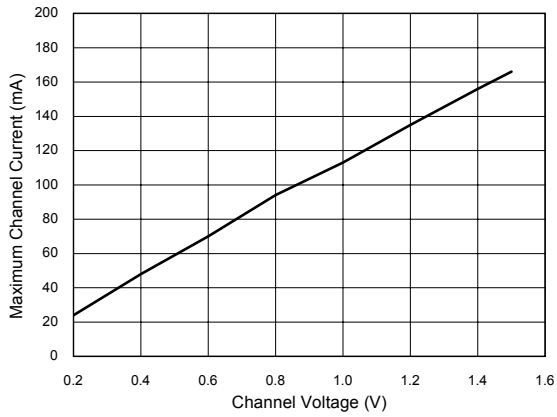

Figure 4. Maximum Channel Current vs. Channel Voltage

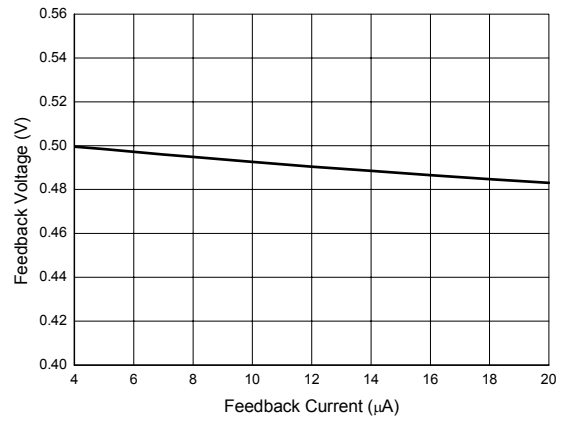

Figure 5. Feedback Voltage vs. Feedback Current

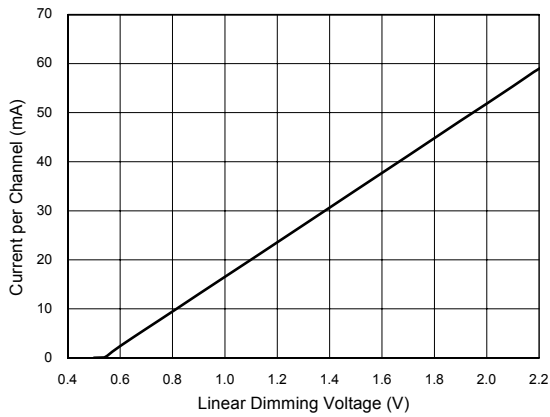

Figure 6. Channel Current vs. Linear Dimming Voltage

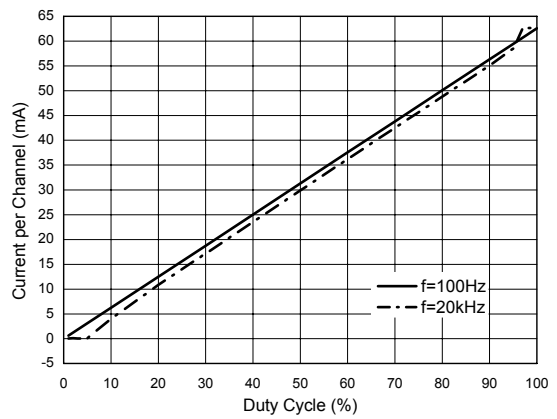

Figure 7. Current per Channel vs. Duty Cycle (PWM Dimming)



**SIXTEEN-CHANNEL, 75mA CURRENT SINK WITH CURRENT MATCH AP3616**

**Typical Performance Characteristics (Continued)**

$V_{IN}=24V$ ,  $V_{EN}=5V$ ,  $R_{ISET}=30k\Omega$ ,  $T_A=25^\circ C$ , unless otherwise specified.

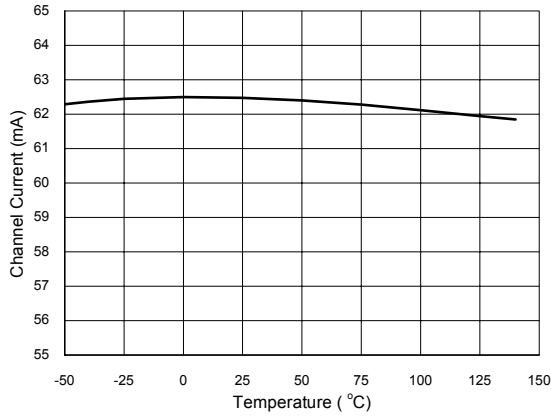

Figure 8. Channel Current vs. Temperature

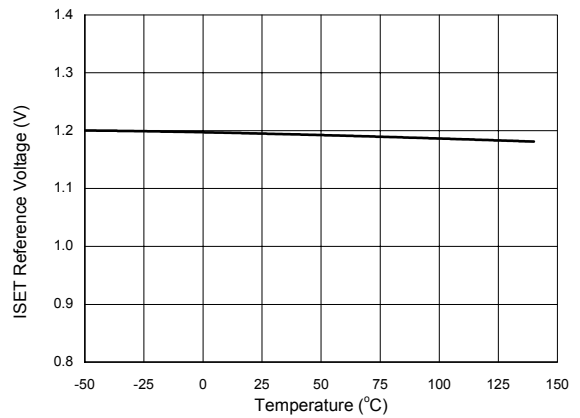

Figure 9. ISET Reference Voltage vs. Temperature

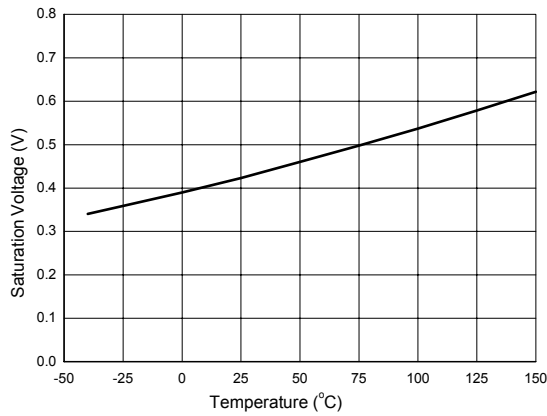

Figure 10. Saturation Voltage vs. Temperature

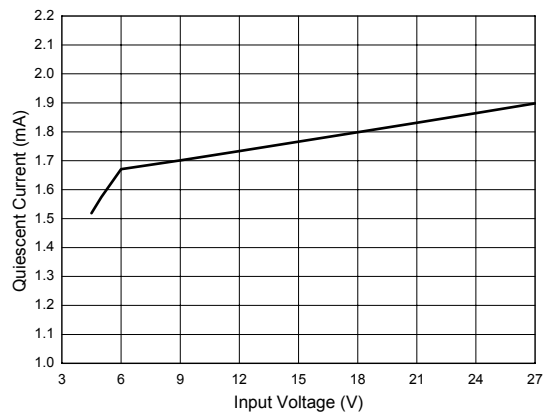

Figure 11. Quiescent Current vs. Input Voltage



**SIXTEEN-CHANNEL, 75mA CURRENT SINK WITH CURRENT MATCH AP3616**

**Typical Performance Characteristics (Continued)**

$V_{IN}=24V$ ,  $V_{EN}=5V$ ,  $R_{ISET}=30k\Omega$ ,  $T_A=25^\circ C$ , unless otherwise specified.

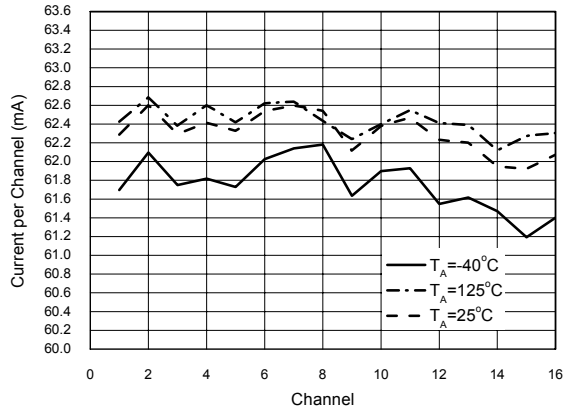

Figure 12. Current per Channel vs. Channel

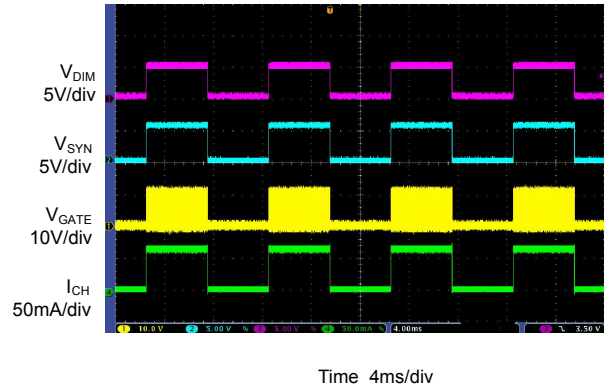

Figure 13. PWM Dimming ( $f=100Hz$ , Duty Cycle=50%)

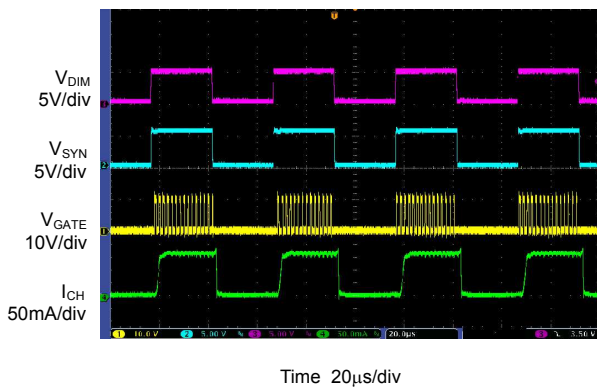

Figure 14. PWM Dimming ( $f=20kHz$ , Duty Cycle=50%)

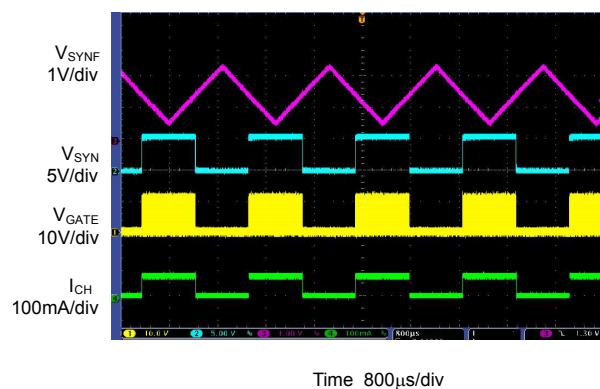
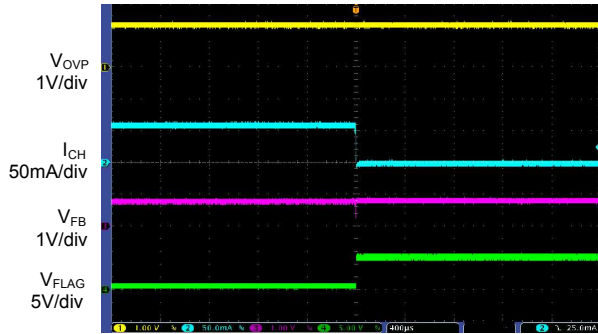

Figure 15. Linear Dimming ( $V_{DIM}=1.4V$ )

**SIXTEEN-CHANNEL, 75mA CURRENT SINK WITH CURRENT MATCH AP3616**

**Typical Performance Characteristics (Continued)**

$V_{IN}=24V$ ,  $V_{EN}=5V$ ,  $R_{ISET}=30k\Omega$ ,  $T_A=25^\circ C$ , unless otherwise specified.



Time 400µs/div

Figure 16. LED Open Protection

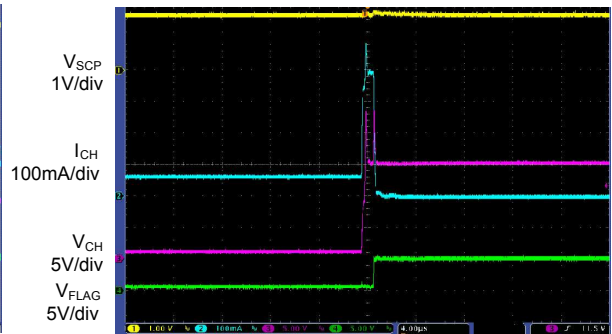

Time 4µs/div

Figure 17. LED Short Protection

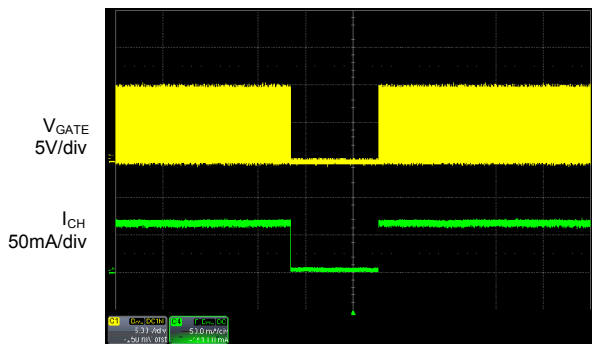

Time 2s/div

Figure 18. OTP and Recovery

**SIXTEEN-CHANNEL, 75mA CURRENT SINK WITH CURRENT MATCH AP3616****Function Description****1. LED Current Setting**

The maximum LED current per channel can be adjusted up to 75mA via ISET pin. When  $\geq 75\text{mA}$  current is needed in application, two or more channels can be paralleled to provide larger drive current. Connect a resistor  $R_{ISET}$  between ISET pin and GND to set the reference current  $I_{SET}$ . The LED current is determined by the following equation.

$$I_{LED} (mA) = \frac{k \cdot V_{ISET}}{R_{ISET} (k\Omega)} = \frac{1560 \times 1.194}{R_{ISET} (k\Omega)}$$

**2. Dimming Control**

The AP3616 provides two dimming methods: external PWM signal or DC voltage input. Applying a PWM signal to DIM pin to adjust the LED current, that means, the LED current of all enabled channels can be adjusted at the same time and the LED brightness can be adjusted from  $1\% \cdot I_{CHX\_MAX}$  to  $100\% \cdot I_{CHX\_MAX}$ . During the high level period of PWM signal, the LED is turned on and 100% of the current flows through LED, while during the low level period of the PWM signal, the LED is turned off and almost no current flows through the LED, thus changing the average current through LED and finally adjusting LED brightness. The external PWM signal frequency applied to PWM pin is allowed to be 80Hz or higher.

**3. Over Voltage Protection**

The AP3616 integrates an OVP circuit. The OVP pin is connected to the center tap of voltage-divider ( $R_{OV3}$  and  $R_{OV4}$ ) that placed between high voltage output and GND (Figure 19). If the voltage on OVP pin exceeds 1.194V, which may results from open loop or excessive output voltage, the AP3616 will start LED open protection.

$$V_{OVP} = \frac{(R_{OV3} + R_{OV4}) \times 1.194V}{R_{OV4}}$$

**4. LED Short-circuit Protection**

The AP3616 integrates an LED short-circuit protection circuit. During normal operation, any short-circuited LED will cause the corresponding LED pin voltage to rise. If any LED pin voltage exceeds 8 times of the voltage at SCP pin, the corresponding LED current sink will be latched off, while the remaining string(s) keep normal operation. Toggle the VIN and/or EN to reset the latch. An internal current source was connected to this pin, a resistor connected here is used to set the shorting LED trigger voltage.

**5. LED Open-circuit Protection**

The AP3616 integrates an LED Open-Circuit Protection circuit. When any LED string is open,  $V_{OUT}$  will boost up until the voltage at OVP pin reaches an approximate 1.194V threshold. The IC will automatically ignore the open string(s) whose CHX pin voltage is less than 100mV.

**SIXTEEN-CHANNEL, 75mA CURRENT SINK WITH CURRENT MATCH AP3616**

**Typical Application**

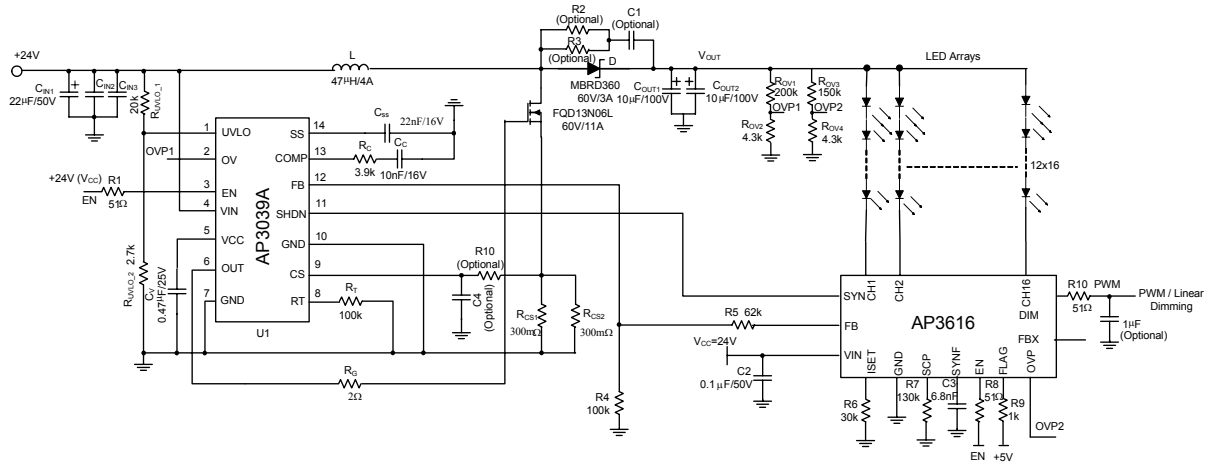

Single Chip Application (12S16P)

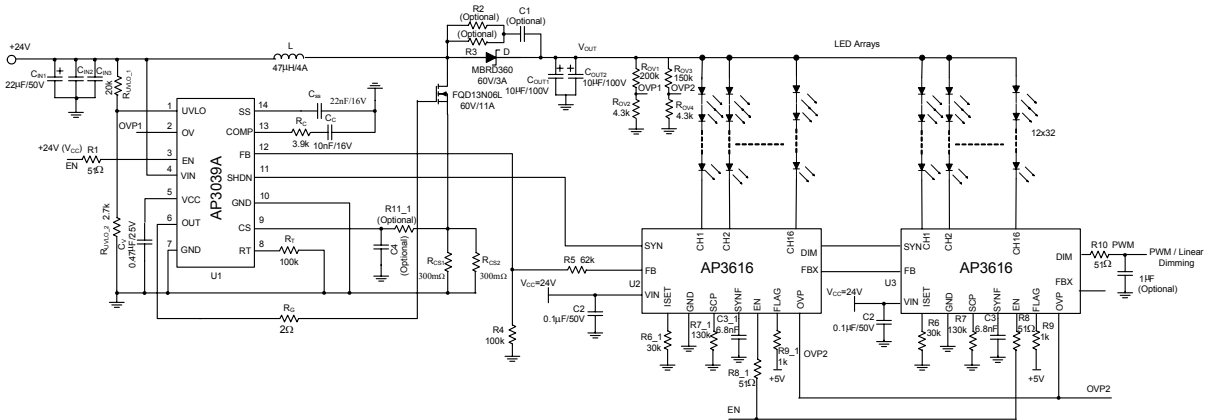

Multi Chips Application (12S32P)

Figure 19. Typical Applications of AP3616



**SIXTEEN-CHANNEL, 75mA CURRENT SINK WITH CURRENT MATCH AP3616**

**Mechanical Dimensions**

**SOIC-28**

**Unit: mm(inch)**

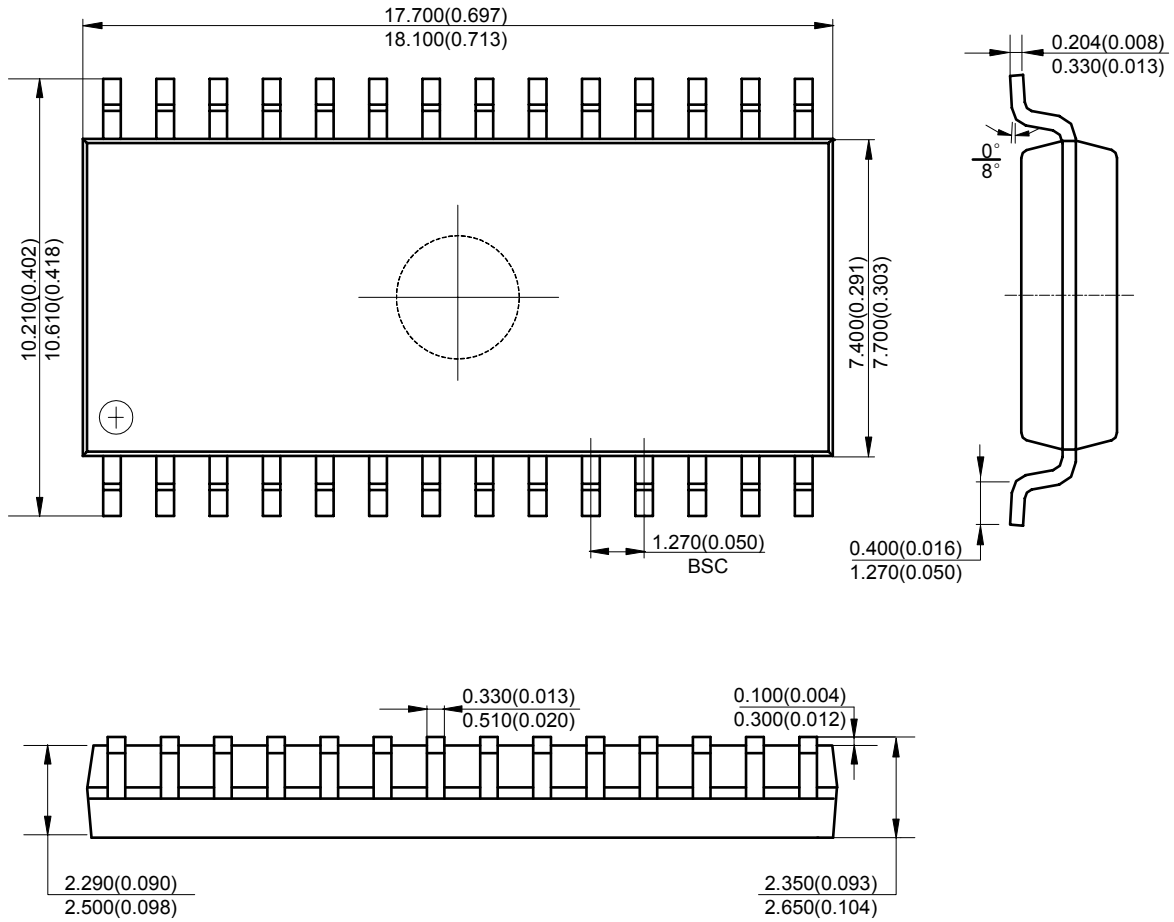

Note: Eject hole, oriented hole and mold mark is optional.



**SIXTEEN-CHANNEL, 75mA CURRENT SINK WITH CURRENT MATCH AP3616**

**Mechanical Dimensions (Continued)**

**HSOP-28**

**Unit: mm(inch)**

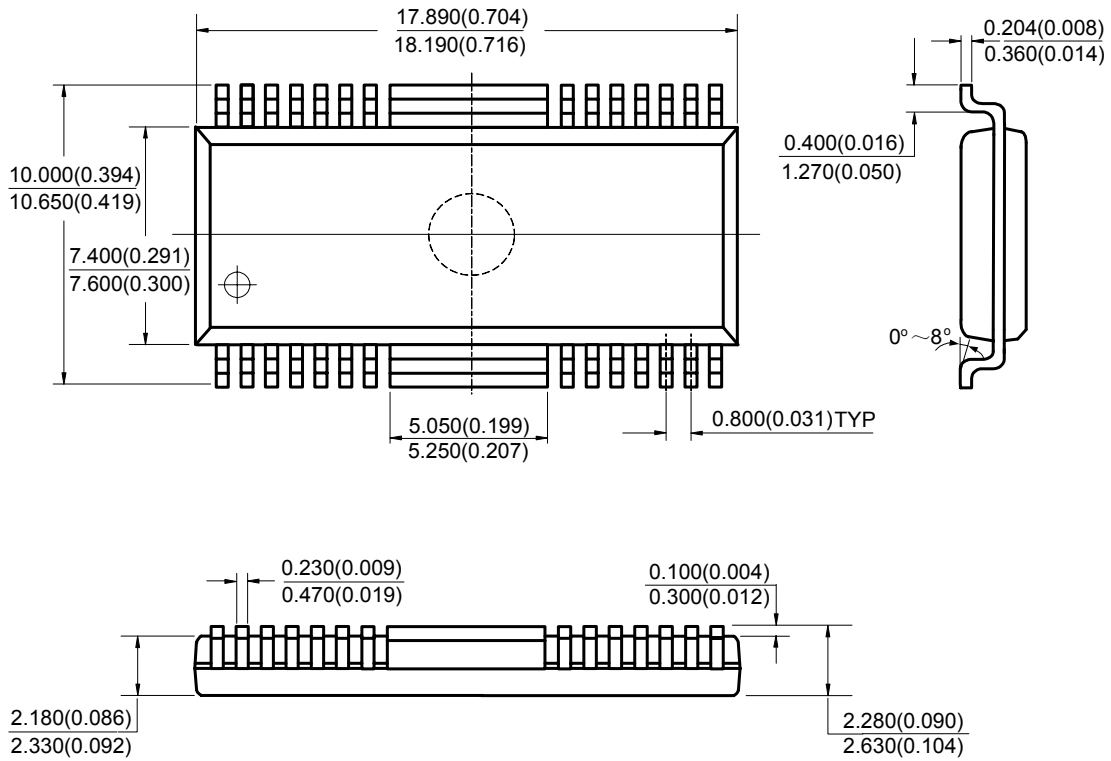

Note: Eject hole, oriented hole and mold mark is optional.





## **BCD Semiconductor Manufacturing Limited**

<http://www.bcdsemi.com>

### **IMPORTANT NOTICE**

BCD Semiconductor Manufacturing Limited reserves the right to make changes without further notice to any products or specifications herein. BCD Semiconductor Manufacturing Limited does not assume any responsibility for use of any its products for any particular purpose, nor does BCD Semiconductor Manufacturing Limited assume any liability arising out of the application or use of any its products or circuits. BCD Semiconductor Manufacturing Limited does not convey any license under its patent rights or other rights nor the rights of others.

---

#### **MAIN SITE**

##### **- Headquarters**

##### **BCD Semiconductor Manufacturing Limited**

No. 1600, Zi Xing Road, Shanghai Zizhu Science-based Industrial Park, 200241, China  
Tel: +86-21-24162266, Fax: +86-21-24162277

##### **- Wafer Fab**

##### **Shanghai SIM-BCD Semiconductor Manufacturing Co., Ltd.**

800 Yi Shan Road, Shanghai 200233, China  
Tel: +86-21-6485 1491, Fax: +86-21-5450 0008

#### **REGIONAL SALES OFFICE**

##### **Shenzhen Office**

##### **Shanghai SIM-BCD Semiconductor Manufacturing Co., Ltd., Shenzhen Office**

Unit A Room 1203, Skyworth Bldg., Gaoxin Ave. 1.S., Nanshan District, Shenzhen, China  
Tel: +86-755-8826 7951  
Fax: +86-755-8826 7865

##### **Taiwan Office**

##### **BCD Semiconductor (Taiwan) Company Limited**

4F, 298-1, Rui Guang Road, Nei-Hu District, Taipei, Taiwan  
Tel: +886-2-2656 2808  
Fax: +886-2-2656 2806

##### **USA Office**

##### **BCD Semiconductor Corp.**

30920 Huntwood Ave. Hayward, CA 94544, USA  
Tel : +1-510-324-2988  
Fax: +1-510-324-2788