



Chipsmall Limited consists of a professional team with an average of over 10 year of expertise in the distribution of electronic components. Based in Hongkong, we have already established firm and mutual-benefit business relationships with customers from,Europe,America and south Asia,supplying obsolete and hard-to-find components to meet their specific needs.

With the principle of “Quality Parts,Customers Priority,Honest Operation,and Considerate Service”,our business mainly focus on the distribution of electronic components. Line cards we deal with include Microchip,ALPS,ROHM,Xilinx,Pulse,ON,Everlight and Freescale. Main products comprise IC,Modules,Potentiometer,IC Socket,Relay,Connector.Our parts cover such applications as commercial,industrial, and automotives areas.

We are looking forward to setting up business relationship with you and hope to provide you with the best service and solution. Let us make a better world for our industry!



Contact us

Tel: +86-755-8981 8866 Fax: +86-755-8427 6832

Email & Skype: info@chipsmall.com Web: www.chipsmall.com

Address: A1208, Overseas Decoration Building, #122 Zhenhua RD., Futian, Shenzhen, China



Specification Sheet

USB2.0 Flash Drive Handy Steno AH328



Table of Contents

1. Product Introduction.....	3
2. Product Features.....	3
3. Specifications.....	4
4. Physical Dimension.....	4

1. Product Introduction

A True Classical Piece Blending Technology and Aesthetics

Handy Steno AH328 leads the pack in the market with stylish and professional design. It showcases a metal-like, hairline and silver case with an etched Apacer logo and four refined screw-cap carvings on the corners, exuding sophistication and understated elegance. In addition to the well designed exteriors, AH328 encompasses many useful features on the back.

The strap hole allows the user to carry or attach this nifty USB drive easily, offering true portability and convenience. And the sliding push key on the back integrates the functionality of a retractable USB drive and look of an exquisite high-tech product.

2. Product Features

- USB 2.0 Hi-Speed interface
- Easy plug & play
- Retractable USB connector- Capless design
- Metal-like hairline design
- Strap hole: Allow easy carry
- RoHS compliant

3. Specifications

Specifications	
Interface	High-speed USB 2.0 certified, backwards compatible with USB 1.1
Power supply	USB bus powered No external power required
Operating Systems Supported	Windows XP/2000/Vista/7, Mac OS 10.4 and Linux 2.6.4 or above
Capacity	4GB~ 32GB
Operating Temperature	0° C to +60° C (32° F to 140° F)
Storage Temperature	-20° C to +60° C (-4° F to +140° F)
Dimensions	(L) 54.6 x (W) 20.6 x (H) 8.6 mm
Weight	8g

4. Physical Dimension

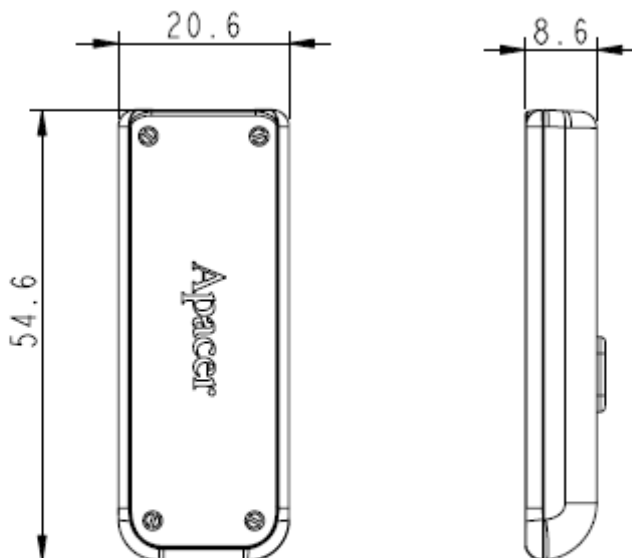

Tolerance: ±0.2mm