



Chipsmall Limited consists of a professional team with an average of over 10 year of expertise in the distribution of electronic components. Based in Hongkong, we have already established firm and mutual-benefit business relationships with customers from,Europe,America and south Asia,supplying obsolete and hard-to-find components to meet their specific needs.

With the principle of "Quality Parts,Customers Priority,Honest Operation,and Considerate Service",our business mainly focus on the distribution of electronic components. Line cards we deal with include Microchip,ALPS,ROHM,Xilinx,Pulse,ON,Everlight and Freescale. Main products comprise IC,Modules,Potentiometer,IC Socket,Relay,Connector.Our parts cover such applications as commercial,industrial, and automotives areas.

We are looking forward to setting up business relationship with you and hope to provide you with the best service and solution. Let us make a better world for our industry!



Contact us

Tel: +86-755-8981 8866 Fax: +86-755-8427 6832

Email & Skype: info@chipsmall.com Web: www.chipsmall.com

Address: A1208, Overseas Decoration Building, #122 Zhenhua RD., Futian, Shenzhen, China



Avalanche Photodiodes (APD) – APD EVAL BOARD Evaluation Board User Guide

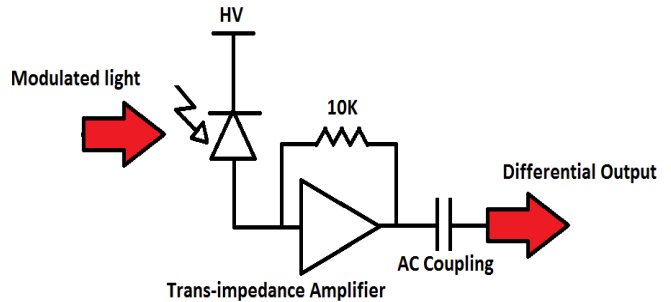
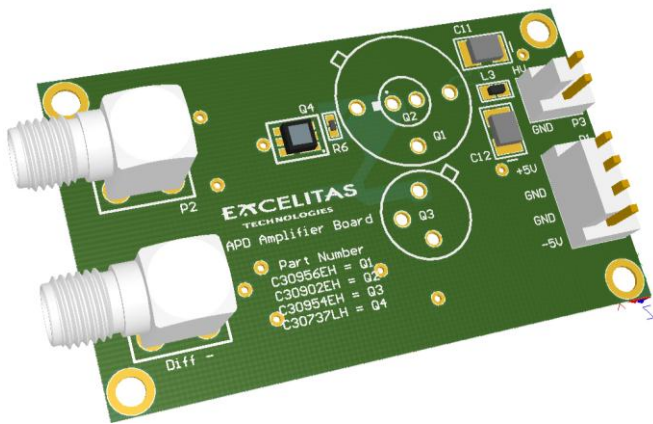

Overview

Avalanche photodiode detectors (APDs) have and will continue to be used in many diverse applications such as laser range finders, data communications or photon correlation studies. This user guide describes the the function and method to use the evaluation board for testing Excelitas Silicon and InGaAs avalanche photodiodes.

This evaluation module is intended to provide the customer with a simple, turn-key platform to use and test the APDs. This board is designed to be versatile in accommodating four main APD packages: TO-5, TO-8, TO-18 and laminated cermic carrier (LCC). There is a transimpedance amplifier on-board for easy measurement of the APD signal. The customer supplies the low voltage for the amplifier and the high voltage to bias the APD.

Contents

- Overview
- Installing APD
- Connecting the board
- DC Coupling
- Schematic
- Ordering Guide

Applications

- Laser range finding
- LIDAR
- Fluorescence detection
- Radiation detection and monitoring
- X-ray detection
- Flow cytometry
- Analytical instrumentation

Avalanche Photodiode (APD) – APD EVAL BOARD

Evaluation Board User Guide

Evaluation Board Overview

The Excelitas APD Evaluation board includes:

- Fully assembled PCB, **part#: APD EVAL BOARD**

The user will need the following to work with the board:

- APD device
- Modulated light source
- 2x SMA cables
- Molex connector housing, pins and wire
- High voltage power supply (1mA @ 400VDC Max)
- Low voltage power supply (-/+5V 300mA)
- High speed oscilloscope (Recommend: 500MHz, 2-channels)
- Optional: Pomona box (Pomona aluminium die cast box 2417)

Recommendation or precautions to the set up and use:





- High voltage supply current limitation is crucial to protect against improper connection
- The board and APD devices should only be handled at an ESD-safe work station

How to install the APD

The standard APD offerings usable with this evaluation board are the hermetic 3pin TO-5, 3pin TO-8, 2pin TO-18 and the laminated ceramic carrier with bottom contact pads.

For surface mount package (LLC, leadless laminated carrier), solder the part onto the appropriate footprint. To remove the part from the PCB, it is preferable to remove the associated “0” Ω resistor (R6) and leave the device soldered onto the board. The function of the circuit will not be affected if the resistor is removed.

For hermetic TO-through hole devices, insert the device into the appropriate receptacles. Adjust pins if needed to properly align with socket holes on the PCB:

-  TO-5 to be mounted on Q3 (in yellow)
-  TO-8 to be mounted on Q1 (in blue)
-  TO-18 to be mounted on Q2 (in red)
-  6-pin LLC to be mounted on Q4 (in pink)

See Figure 1 for various package installation positions.

It is recommended to install 1 APD device on the PCB at a time for testing.

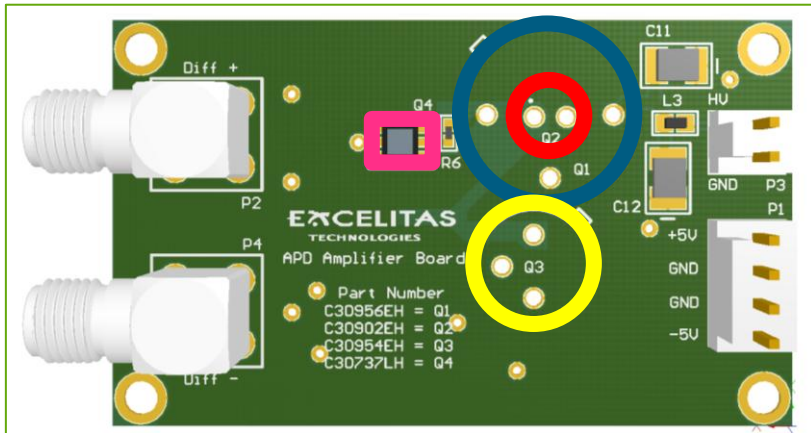

Figure 1: PCB layout

How to connect the supply voltages to the evaluation board

- The low voltage supply, +/-5V, for the amplifier is to be applied to the P1 connector. Use the MOLEX 22-01-3047 connector housing and corresponding pins to make matching connector. Pinout is indicated on the PCB . Current draw should be around 40mA.
- The high voltage supply for APD bias is to be applied to the P3 connector. Use the MOLEX 22-01-3027 connector housing and corresponding pins to make matching connector. Polarity of the high voltage needs to be verified before applying full voltage.

Recommended conditions and set up before applying bias to the APD:

1. Set a low current limit on the high voltage source. (10nA for example)
2. Apply a low voltage to the APD, above the minimum of 3.5V. (4V for example)
3. Verify that the current limit is not reached (as indicated at point 1 above, i.e. 10nA). If the limit is reached, this means the polarity is inverted on the APD. In this case, reverse the polarity of the high voltage bias to resume proper normal operation.
4. Raise the voltage bias and current limit to the operating voltage of the APD, or to the required level for the experiment/testing condition.

How to make this evaluation DC coupled

This evaluation board has 2 AC coupled outputs. It is possible to modify the board to allow DC usage. To do so, remove the C14 and C15 capacitor and replace them with a 0Ω resistor. The board can ONLY drive high impedance loads (i.e., 1MΩ) when DC coupled. Should this modification be done to the board, the normal warranty will be void and the board cannot be returned to Excelitas in case of malfunction.

Evaluation Board User Guide

Table 1. Electrical specifications

Parameter	Minimum	Typical	Maximum	Unit
Product				
Low voltage supply	±4.5		±5.5	V
Low voltage current		25	26	mA
Bandwidth		200		MHz
High voltage supply	3.5		450	V
High voltage current			350	uA
Output impedance		50		Ω
Transimpedance				
differential output, 100Ω load		10		kΩ
single ended, 50Ω load		20		kΩ
Output offset voltage				
Normal, AC coupled output		0		V
Modified, DC coupled output (High Z)		3.7		V
Low cut-off frequency		35		kHz
Output voltage swing				
differential output, 100Ω load		0.6		V
single ended, 50Ω load		1		V

Simplified Schematic

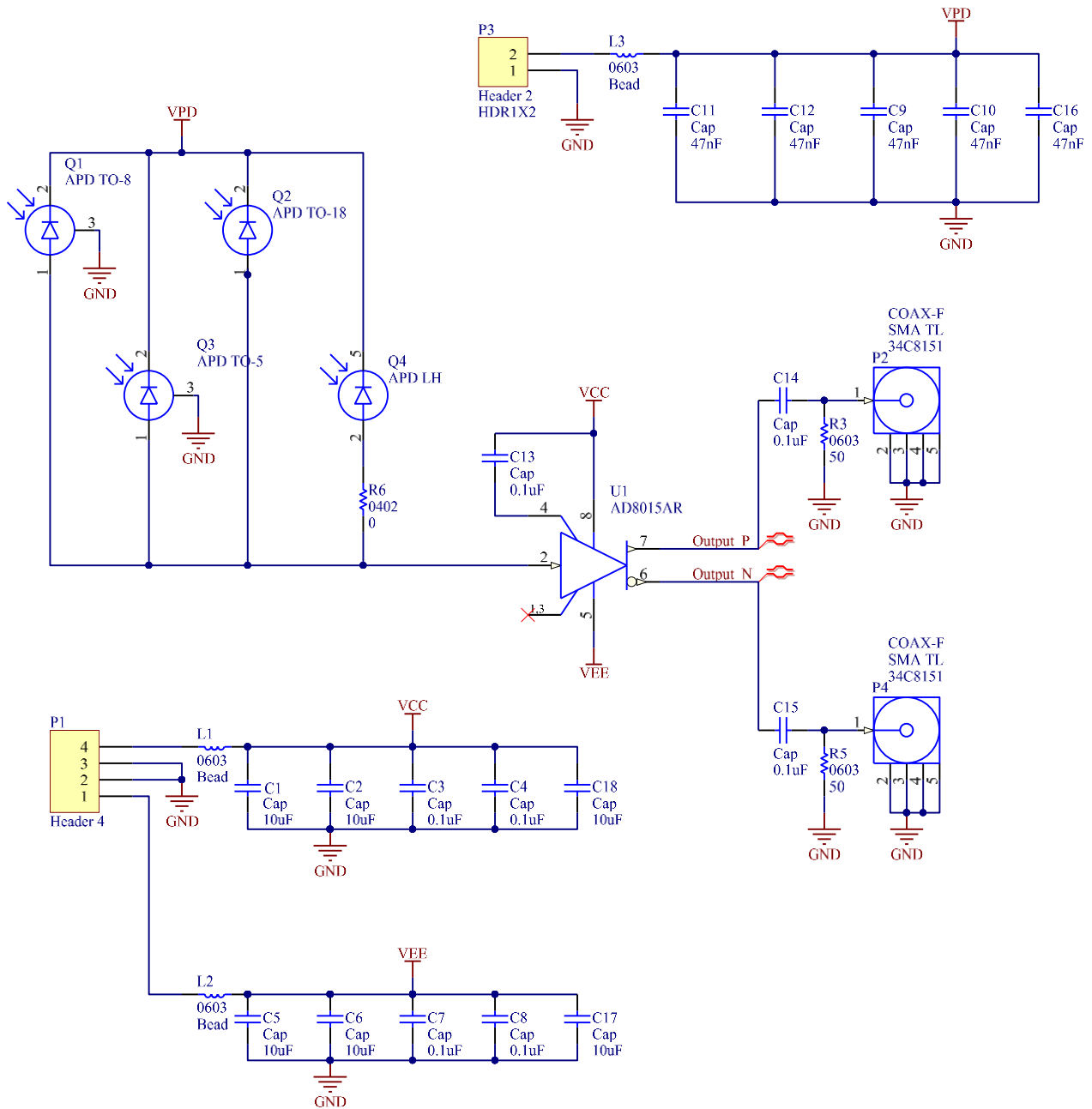

Avalanche Photodiode (APD) – APD EVAL BOARD

Evaluation Board User Guide

Ordering Guide

Part Number is: **APD EVAL BOARD**

About Excelitas Technologies

Excelitas Technologies is a global technology leader focused on delivering innovative, customized solutions to meet the lighting, detection and other high-performance technology needs of OEM customers.

Excelitas has a long and rich history of serving our OEM customer base with optoelectronic sensors and modules for more than 45 years beginning with PerkinElmer, EG&G, and RCA. The constant throughout has been our innovation and commitment to delivering the highest quality solutions to our customers worldwide.

From aerospace and defense to analytical instrumentation, clinical diagnostics, medical, industrial, and safety and security applications, Excelitas Technologies is committed to enabling our customers' success in their specialty end-markets. Excelitas Technologies has approximately 5,000 employees in North America, Europe and Asia, serving customers across the world.

Excelitas Technologies
22001 Dumberry Road
Vaudreuil-Dorion, Quebec
Canada J7V 8P7
Telephone: (+1) 450.424.3300
Toll-free: (+1) 800.775.6786
Fax: (+1) 450.424.3345
detection.na@excelitas.com

**Excelitas Technologies
GmbH & Co. KG**
Wenzel-Jaksch-Str. 31
D-65199 Wiesbaden
Germany
Telephone: (+49) 611 492 430
Fax: (+49) 611 492 165
detection.europe@excelitas.com

Excelitas Technologies Singapore, Pte. Ltd.
8 Tractor Road
Singapore 627969
Telephone: (+65) 6775 2022 (Main number)
Telephone: (+65) 6770 4366 (Customer
Service)
Fax: (+65) 6778-1752
detection.asia@excelitas.com



For a complete listing of our global offices, visit www.excelitas.com/locations

© 2015 Excelitas Technologies Corp. All rights reserved. The Excelitas logo and design are registered trademarks of Excelitas Technologies Corp. All other trademarks not owned by Excelitas Technologies or its subsidiaries that are depicted herein are the property of their respective owners. Excelitas reserves the right to change this document at any time without notice and disclaims liability for editorial, pictorial or typographical errors.