



Chipsmall Limited consists of a professional team with an average of over 10 year of expertise in the distribution of electronic components. Based in Hongkong, we have already established firm and mutual-benefit business relationships with customers from,Europe,America and south Asia,supplying obsolete and hard-to-find components to meet their specific needs.

With the principle of “Quality Parts,Customers Priority,Honest Operation,and Considerate Service”,our business mainly focus on the distribution of electronic components. Line cards we deal with include Microchip,ALPS,ROHM,Xilinx,Pulse,ON,Everlight and Freescale. Main products comprise IC,Modules,Potentiometer,IC Socket,Relay,Connector.Our parts cover such applications as commercial,industrial, and automotives areas.

We are looking forward to setting up business relationship with you and hope to provide you with the best service and solution. Let us make a better world for our industry!



Contact us

Tel: +86-755-8981 8866 Fax: +86-755-8427 6832

Email & Skype: info@chipsmall.com Web: www.chipsmall.com

Address: A1208, Overseas Decoration Building, #122 Zhenhua RD., Futian, Shenzhen, China



Data Sheet

Description

The APDS-9009 is a low cost analog-output ambient light photo sensor in an 8-pin ODFN lead-free surface mount package. It consists of a photo sensor, whose spectral response is close to the CIE standard photopic observer, as show in [Figure 2](#). The APDS-9009 is ideal for applications in which the measurement of ambient light is used to control display backlighting. Mobile appliances such as the mobile phones and PDAs that draw heavy current from display backlighting will benefit from incorporating these photo sensor products in their designs by reducing power consumption significantly.

Application Support Information

The Application Engineering Group is available to assist you with the application design associated with APDS-9009 ambient light photo sensor module. You can contact them through your local sales representatives for additional details.

Features

- Spectral responsivity close to that of human eye
- 8-pin ODFN lead-free surface-mount package
 - Height – 0.34 mm
 - Width – 2.00 mm
 - Depth – 2.00 mm
- Low sensitivity variation across various light sources
- Recommended operating temperature: –40 °C to 85 °C
- Vcc supply 1.8 to 5.5 V
- Lead-free package, RoHS compliance
- Output linearity across wide illumination range

Applications

- Detection of ambient light to control display backlighting
 - Mobile devices – Mobile phones, PDAs
 - Computing devices – Notebooks, Webpads
 - Consumer devices – TVs, Video Cameras, Digital Still Camera
- Automatic Residential and Commercial Lighting Management
- Electronic Signs and Signals

Ordering Information

Part Number	Packaging Type	Package	Quantity
APDS-9009	Tape and Reel	8-pin ODFN package	2500

Typical Application Circuit

Figure 1 Typical Application Circuit for APDS-9009

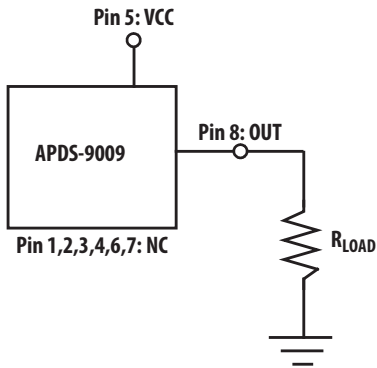

Component	Recommended Application Circuit Component
R _{LOAD}	1 k ohm

NOTE See Figure 11 for General Luminance Vs. Typical Output Voltage for different R_{LOAD} values.

Absolute Maximum Ratings

For implementations where case to ambient thermal resistance is 50 °C /W.

Parameter	Symbol	Min.	Max.	Units
Storage Temperature	T _S	-40	85	°C
Operating temperature	T _A	-40	85	°C
Supply Voltage	V _{CC}	0	6	V

Recommended Operating Conditions

Parameter	Symbol	Min.	Max.	Units	Conditions
Supply Voltage	V _{CC}	1.8	5.5	V	

CAUTION It is advised that normal static precautions be taken in handling and assembly of this component to prevent damage and/or degradation which may be induced by ESD

I/O Pins Configuration Table

Pin	Symbol	Description
1	NC	No Connect
2	NC	No Connect
3	NC	No Connect
4	NC	No Connect
5	VCC	VCC
6	NC	No Connect
7	NC	No Connect
8	I _{out}	Out

Figure 2 Relative Spectral Response Vs. Wavelength

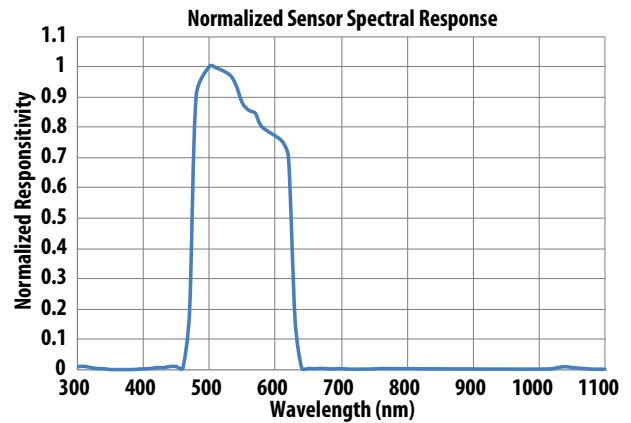

Electrical and Optical Specifications (Ta = 25 °C)

Parameter	Symbol	Min.	Typ.	Max.	Units	Conditions
Photo Current ^a	I _{PH1}	21	30	39	uA	V _{cc} = 1.8V, Lux = 100 ^b
Photo Current ^b	I _{PH2}	—	33	—	uA	V _{cc} = 1.8V, Lux = 100 ^a
Dark Current	I _{DARK}	—	300	—	nA	V _{cc} = 3V, Lux = 0
Light Current Ratio	I _{PH2} / I _{PH1}	—	1.1	—	—	
Rise Time	T _r	—	5	—	ms	R _I = 1K ohm, Lux = 100
Fall Time	T _f	—	5	—	ms	R _I = 1 Kohm, Lux=100
Peak sensitivity wavelength	λ	—	500	—	nm	
Settling Time pulsed at V _{cc}	T _{set}	—	10	—	ms	V _{cc} pulsed = 0V to 3V; R _{load} = 2.4 Kohms; Lux = 100 ^b
Propagation delay	T _d	—	5	—	ms	R _I = 1 Kohm, Lux = 100
Storage delay	T _s	—	5	—	ms	R _I = 1 Kohm, Lux=100
Saturation voltage	V _{sat}	1.0	—	—	V	R _I = 150 Kohm, Lux = 100

a. Illuminance by incandescent lamp

b. White LED is used as a light source

Light Measurement Circuit and Waveforms

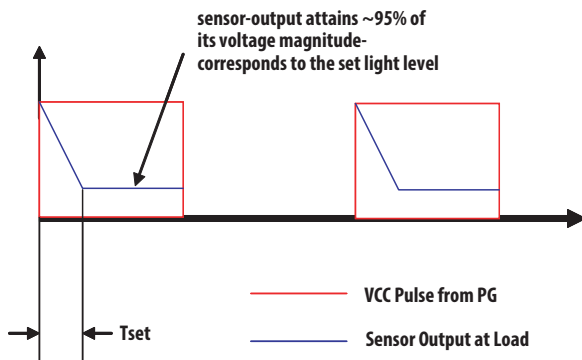
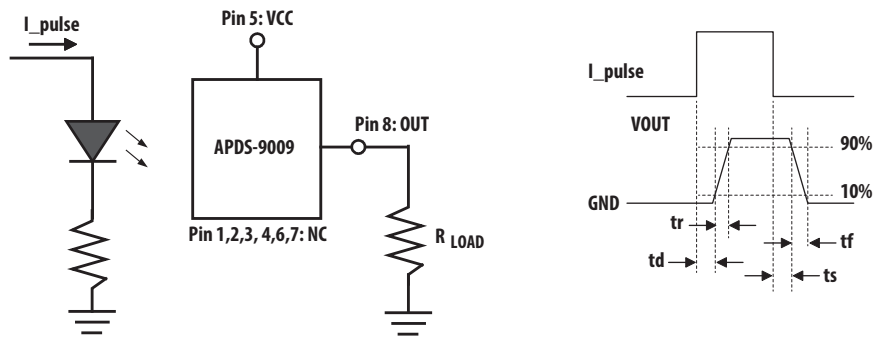

Figure 3 Average IOUT Vs. Lux (Vcc = 1.8V, T=25 °C, White LED Source)

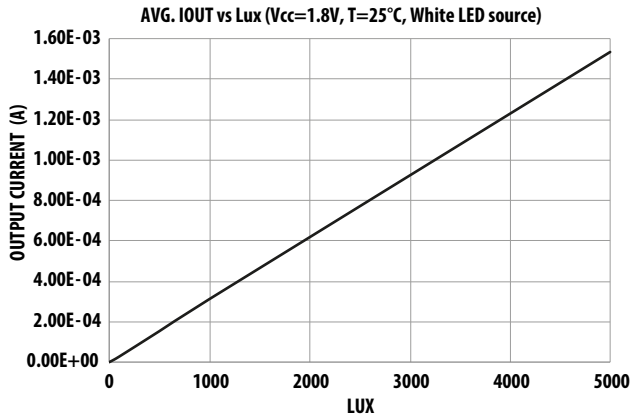

Figure 4 Average relative IOUT Vs. Temp (Vcc = 1.8V, T=25 °C, 100 Lux)

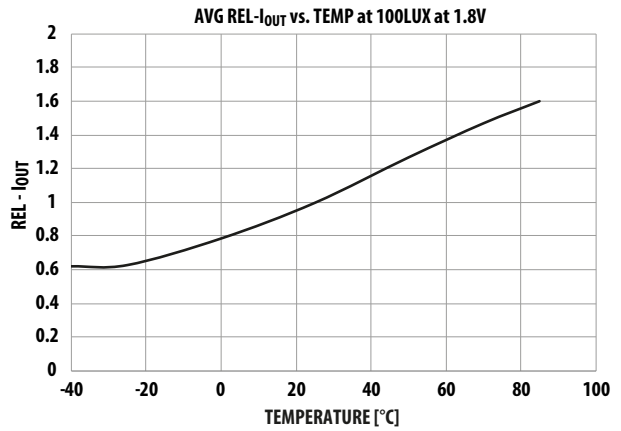

Figure 5 Relative Output Current Vs. Temp (Vcc = 1.8V, 100 Lux)

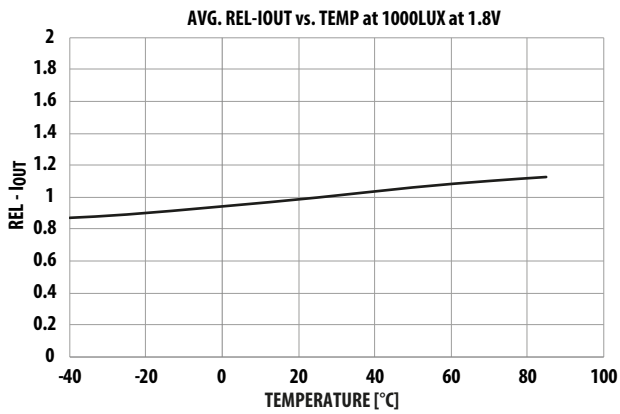

Figure 6 Relative Output Current Vs. Vcc (Ta = 25 °C, 100Lux)

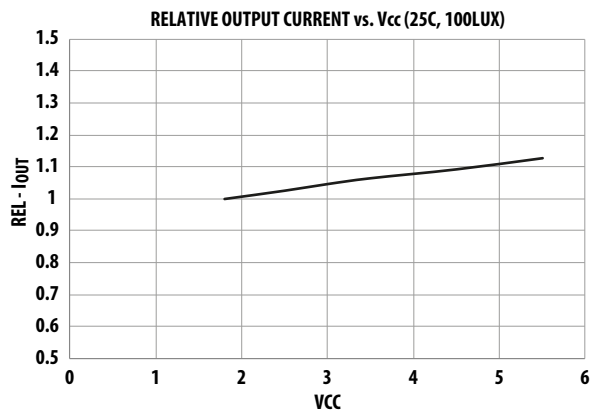

Figure 7 Relative IOUT Vs. Angle (Vcc = 1.8V, Ta = 25 °C)

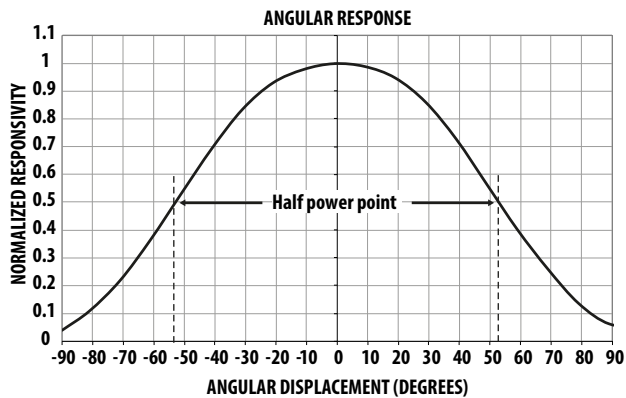

Figure 8 Average Rise Time Vs. Load Resistance at Vcc = 1.8V

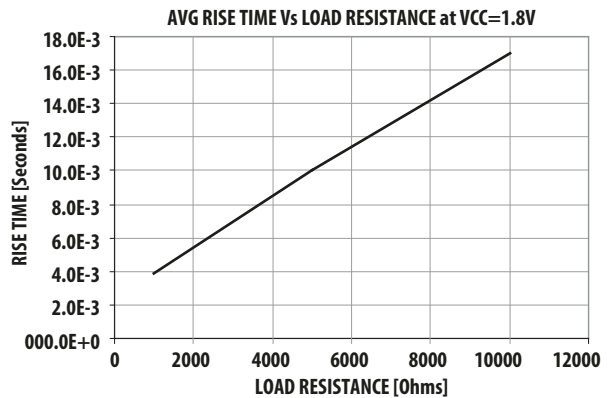

Figure 9 Average Fall Time Vs. Load Resistance at Vcc = 1.8V

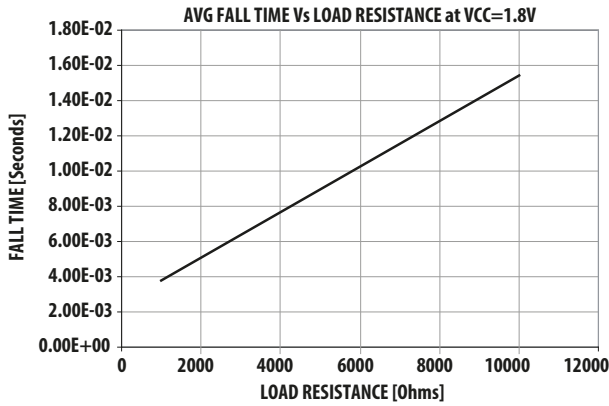

Figure 10 Dark Current Vs. Temperature

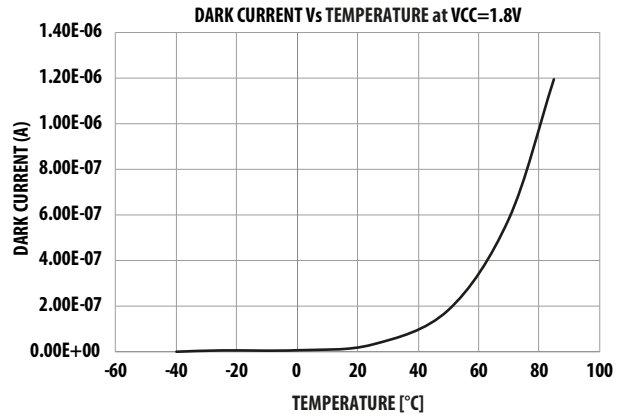
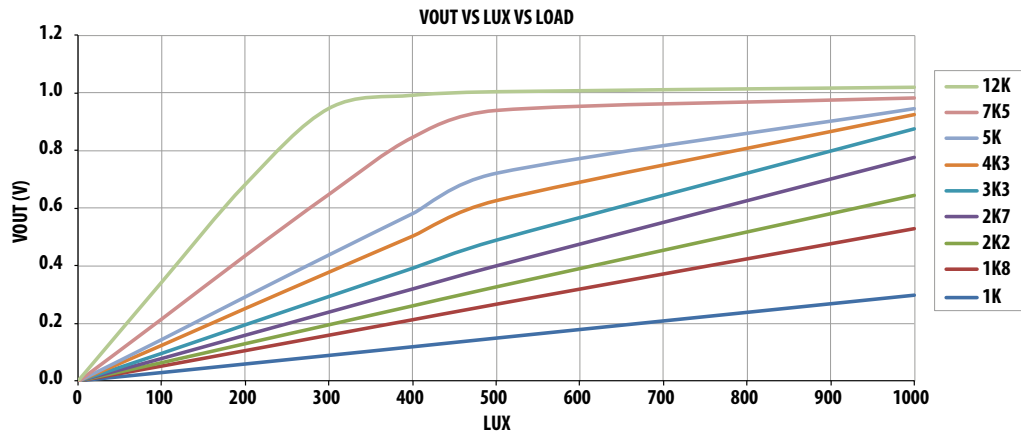
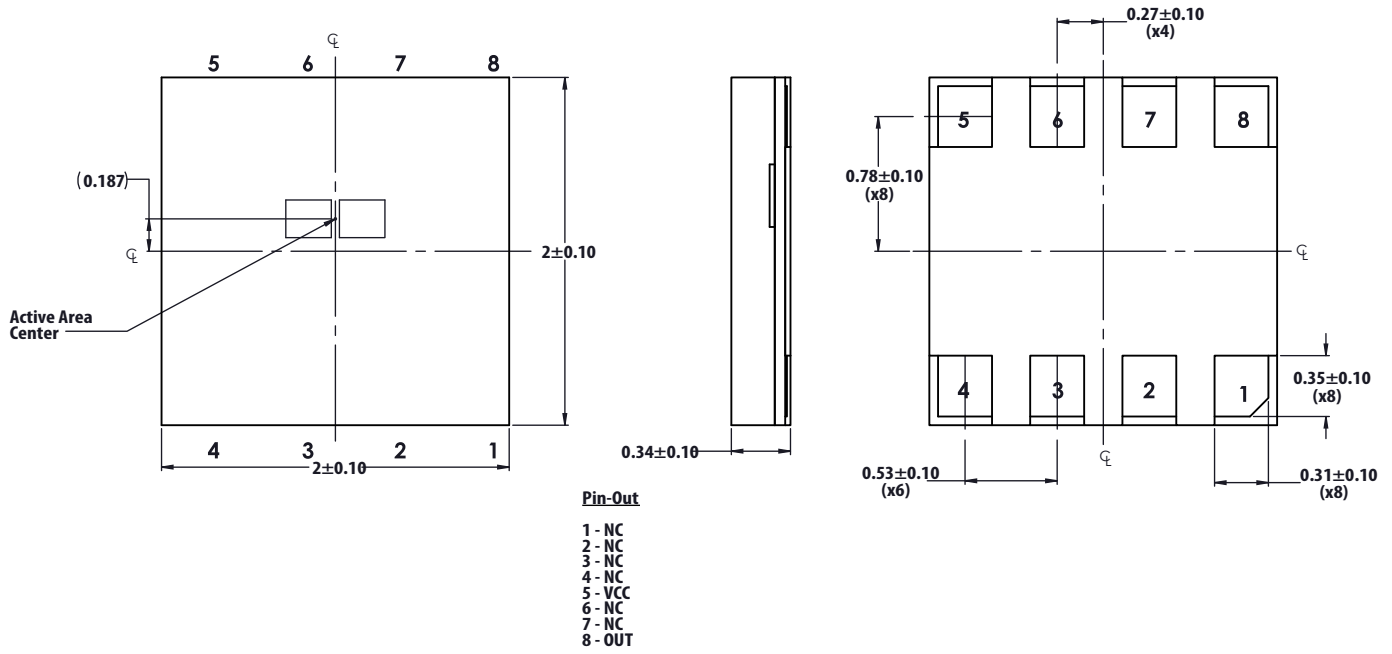

Figure 11 General Luminance vs Typical Output Voltage (Vcc = 1.8V, T = 25 °C, Light Source = White LED)



APDS-9009 Package Outline



PCB Pad Layout

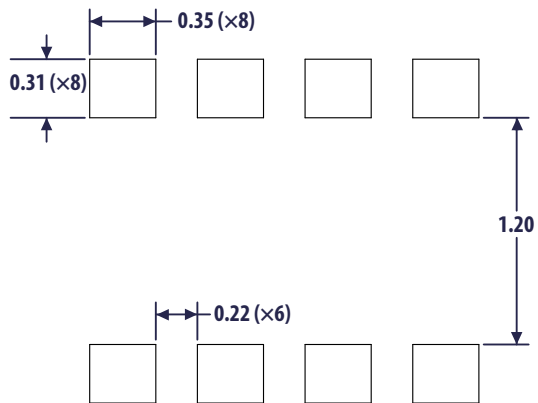

APDS-9009 Tape Dimensions

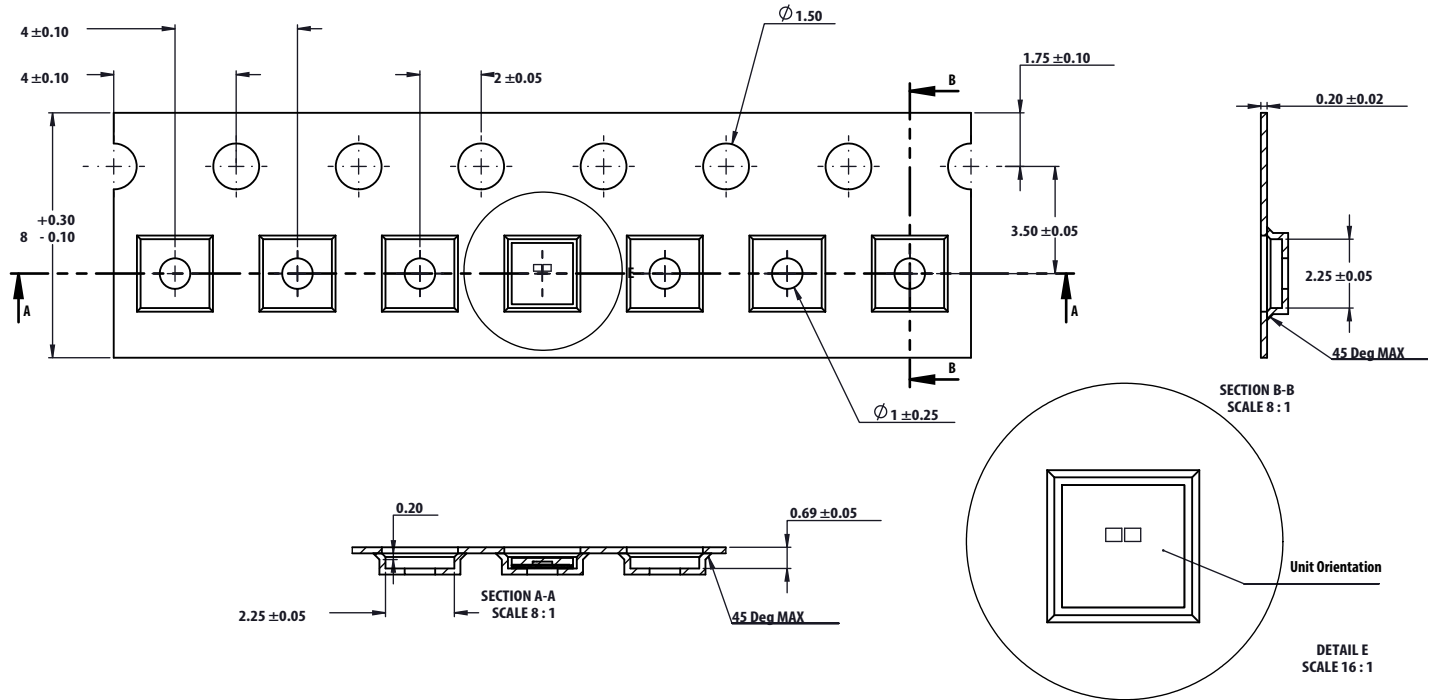

APDS-9009 Reel Dimensions

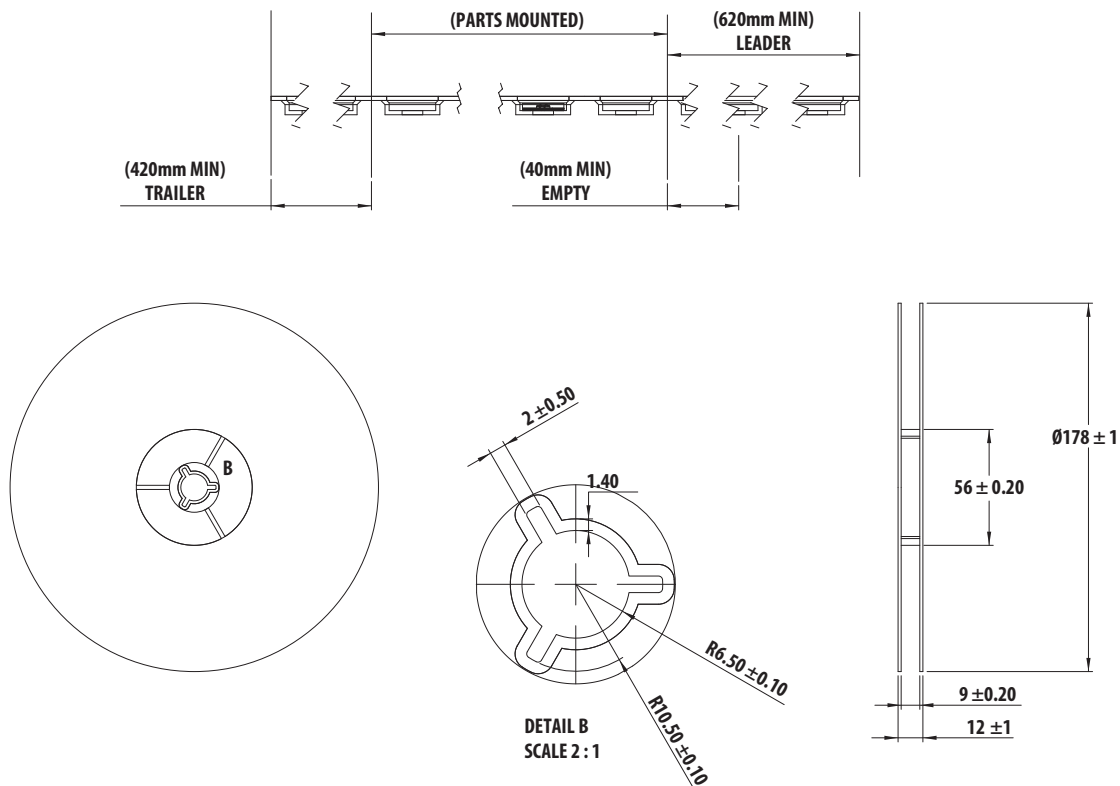

Moisture Proof Packaging

All APDS-9009 options are shipped in moisture proof package. Once opened, moisture absorption begins. This part is compliant to JEDEC Level 3.

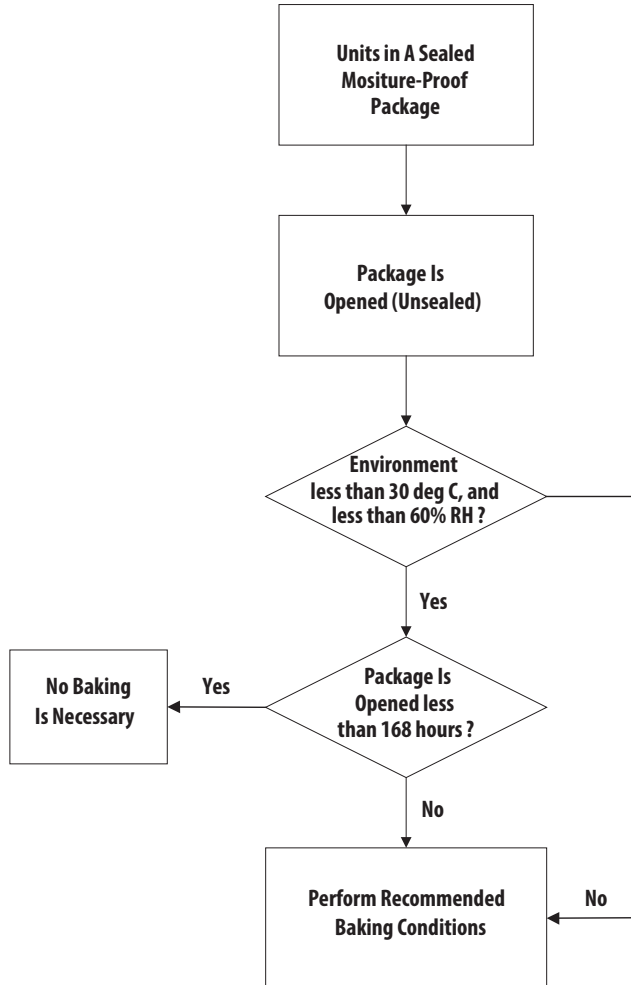

Baking Conditions

If the parts are not stored in dry conditions, they must be baked before reflow to prevent damage to the parts.

Package	Temperature	Time
In Reel	60 °C	48 hours
In Bulk	100 °C	4 hours

Baking should only be done once.

Recommended Storage Conditions

Storage Temperature	10 °C to 30 °C
Relative Humidity	below 60% RH

Time from unsealing to soldering:

After removal from the bag, the parts should be soldered within 7 days and if stored at the recommended storage conditions. If times longer than 7 days are needed, the parts must be stored in a dry box.

Recommended Reflow Profile

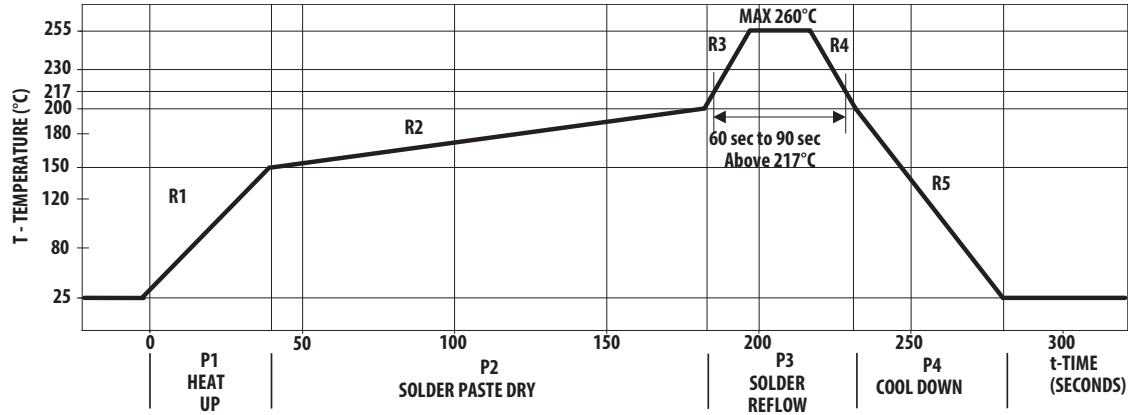

Process Zone	Symbol	ΔT	Maximum $\Delta T/\Delta \text{time}$ or Duration
Heat Up	P1, R1	25 °C to 150 °C	3 °C/s
Solder Paste Dry	P2, R2	150 °C to 200 °C	100 s to 180s
Solder Reflow	P3, R3	200 °C to 255 °C	3 °C/s
	P3, R4	255 °C to 200 °C	-6 °C/s
Cool Down	P4, R5	200 °C to 25 °C	-6 °C/s
Time maintained above 217 °C		> 217 °C	60 s to 90 s
Peak Temperature		260 °C	
Time within 5 °C of actual Peak Temperature		> 255 °C	20 s to 40 s
Time 25 °C to Peak Temperature		25 °C to 260 °C	8 mins

The reflow profile is a straight-line representation of a nominal temperature profile for a convective reflow solder process. The temperature profile is divided into four process zones, each with different $\Delta T/\Delta \text{time}$ temperature change rates or duration. The $\Delta T/\Delta \text{time}$ rates or duration are detailed in the preceding table. The temperatures are measured at the component to printed circuit board connections.

Process zone P1, the PC board and APDS-9009 pins are heated to a temperature of 150 °C to activate the flux in the solder paste. The temperature ramp up rate, R1, is limited to 3 °C per second to allow for even heating of both the PC board and APDS-9009 pins.

Process zone P2 should be of sufficient time duration (100 to 180 seconds) to dry the solder paste. The temperature is raised to a level just below the liquidus point of the solder, usually 200 °C (392 °F).

Process zone P3 is the solder reflow zone. In zone P3, the temperature is quickly raised above the liquidus point of solder to 255 °C (491 °F) for optimum results. The dwell time above the liquidus point of solder should be between 20 and 40 seconds. It usually takes about 20 seconds to assure proper coalescing of the solder balls into liquid solder and the formation of good solder connections. Beyond a dwell time of 40 seconds, the intermetallic growth within the solder connections becomes excessive, resulting in the formation of weak and unreliable connections. The temperature is then rapidly reduced to a point below the solidus temperature of the solder, usually 200°C (392°F), to allow the solder within the connections to freeze solid.

Process zone P4 is the cool down after solder freeze. The cool down rate, R5, from the liquidus point of the solder to 25 °C (77 °F) should not exceed 6 °C per second maximum. This limitation is necessary to allow the PC board and APDS-9009 pins to change dimensions evenly, putting minimal stresses on the APDS-9009.

It is recommended to perform reflow soldering no more than twice.

Appendix A: General Application Guide for APDS-9009

The APDS-9009 is a low cost analog-output ambient light photo sensor whose spectral response closely emulates the human eyes. APDS-9009 consists of a photo sensor that is able to produce a high gain photo current to a sufficient level that can be converted to voltage with a standard value of external resistor. APDS-9009 can easily be integrated into systems that use ADC input which is available for sampling of the external source, as shown in Figure 12.

The amount of converted voltage, V_{out} , is mainly dependent proportionally on the photo current that generated by the brightness of the light shone on the photo sensor and the load resistor used, R_L . Increasing the brightness of the light or/and the load resistor will increase the output voltage.

Brightness is measured as "LUX" unit, which describes how intense a light source that our eyes perceive. LUX meter is the equipment for "LUX" measurement. Light sources with the same LUX level appear at the same brightness to the human eyes.

Selection of the load resistor R_L will determine the amount of current-to-voltage conversion in the circuit.

Light source, e.g., fluorescent light consists of ac noise frequency of about 100Hz. A capacitor of 10 μ F, which act as a low-pass filter, is recommended to add in parallel with the load resistor to reduce the ripples.

Figure 12 Configuration of APDS-9009

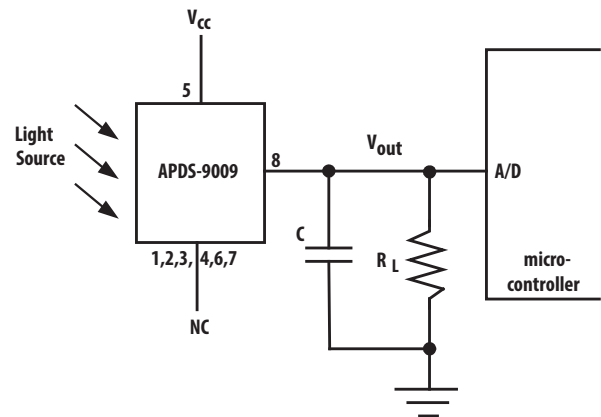

For product information and a complete list of distributors, please go to our web site:

www.avagotech.com

Avago Technologies and the A logo are trademarks of Avago Technologies in the United States and other countries. All other brand and product names may be trademarks of their respective companies.

Data subject to change. Copyright © 2014–2016 Avago Technologies. All Rights Reserved.

AV02-3992EN – April 6, 2016

AVAGO
TECHNOLOGIES

