



Chipsmall Limited consists of a professional team with an average of over 10 year of expertise in the distribution of electronic components. Based in Hongkong, we have already established firm and mutual-benefit business relationships with customers from,Europe,America and south Asia,supplying obsolete and hard-to-find components to meet their specific needs.

With the principle of “Quality Parts,Customers Priority,Honest Operation,and Considerate Service”,our business mainly focus on the distribution of electronic components. Line cards we deal with include Microchip,ALPS,ROHM,Xilinx,Pulse,ON,Everlight and Freescale. Main products comprise IC,Modules,Potentiometer,IC Socket,Relay,Connector.Our parts cover such applications as commercial,industrial, and automotives areas.

We are looking forward to setting up business relationship with you and hope to provide you with the best service and solution. Let us make a better world for our industry!



Contact us

Tel: +86-755-8981 8866 Fax: +86-755-8427 6832

Email & Skype: info@chipsmall.com Web: www.chipsmall.com

Address: A1208, Overseas Decoration Building, #122 Zhenhua RD., Futian, Shenzhen, China



APDS-9800

Integrated Ambient Light and Proximity Sensor



Data Sheet



Description

The APDS-9800 integrates ambient light sensor (ALS), proximity sensor (PS) and ambient light cancellation functions in a single module. The module contains three chips in one small package: an ambient light sensor IC, a proximity sensor signal conditioning circuit and a proximity sensor that includes both an LED emitter and detector.

The ambient light sensor has a spectral response close to the CIE standard photopic observer and a current output.

The proximity sensor signal conditioning circuit has an LED driver and a receiver circuit that has both analog and digital outputs. With the built-in LED, the proximity sensor is able to sense the proximity of an object, such as a finger, hand or head that is close to a portable device. The PS also features an excellent ambient light cancellation circuit for operation in direct sunlight.

By detecting the ambient light illuminance level, the ambient light sensor can control the brightness of display backlights.

The proximity sensor makes many interesting and useful applications possible. For example, a proximity sensor can detect the proximity of a mobile phone user's head and turn off or on the phone keypad and LCD backlight.

By combining an ambient light sensor and proximity sensor in a single compact module, mobile phones, PDAs and notebooks can have additional features or benefit from increased performance, such as in battery life.

Features

- Integrated module with ambient light sensor, proximity sensor and signal conditioning IC
- Small form factor: L 4.95 x W 3.0 x H 1.45 mm
- Supply voltage range: 2.4 V to 3.6 V
- Spectral responsivity closely matches the human eye
- Built-in LED and detector for proximity detection
- Low sensitivity variation across various light sources
- Linear output across a wide illumination range
- Operates under strong sunlight and artificial light
- Controlled LED driving current, pulse and burst parameters
- Controlled output voltage and integration time with an external resistor and capacitor
- LED stuck High protection
- Both analog and digital outputs available
- Shutdown mode for low current consumption
- Lead-free and RoHS compliant

Applications

- PDAs
- Mobile phones
- Portable and handheld devices
- Personal computers, netbooks and notebooks
- Amusement products
- Games
- Vending Machines

Functional Block Diagram

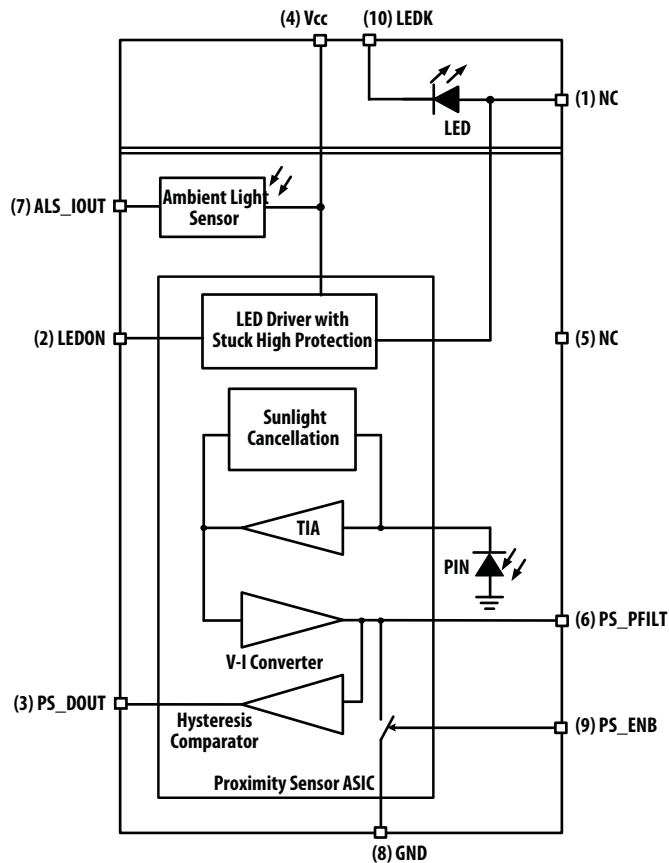

I/O Pins Configuration Table

Pin	Symbol	Type	Description
1	NC	–	No Connection
2	LEDON	Digital I/P	LED Driver Input LEDA will turn off when LEDON is stuck in high state for > Max-PW
3	PS_DOUT	Digital O/P	PS Digital Output (Open drain output that requires a pull-up resistor of recommended value 10kΩ) PS_DOUT = LOW when PS_VPFILT > VTH PS_DOUT = HIGH when PS_VPFILT < VTH
4	Vcc	Supply	Voltage Supply
5	NC	–	No Connection
6	PS_PFILT	Analog O/P	PS Analog Output Connect to integration circuit (R3 and C3)
7	ALS_IOUT	Analog O/P	ALS analog current output Connect to external load resistor R4. Recommended value 1kΩ.
8	GND	Ground	Ground
9	PS_ENB	Digital I/P	PS Power Down Enable ENB = 0 Normal mode operation, ENB = 1 Shut down mode
10	LEDK	Analog O/P	Connect to Cathode of LED (proximity sensor) External current limiting resistor is used to control current flow in the LED

Ordering Information

Part Number	Packaging	Quantity
APDS-9800-021	Tape & Reel	2500 per reel

Absolute Maximum Ratings

Parameter	Symbol	Min.	Max.	Units	Conditions
Supply Voltage	V _{CC}	0	4	V	T _A = 25°C
Input Logic Voltage	V _I	0	4	V	T _A = 25°C
Reflow Soldering Temperature			260	°C	

Recommended Operating Conditions

Parameter	Symbol	Min.	Max.	Units	Conditions
Operating Temperature	T _A	-40	85	°C	
Storage Temperature	T _S	-40	85	°C	
Supply Voltage	V _{CC}	2.4	3.6	V	

Electrical & Optical Specifications (Ta=25°C)

Parameters	Symbol	Minimum	Typical	Maximum	Units	Conditions
ALS+PS Module						
Shutdown Current	I _{SD}	–	0.3	1	μA	V _{CC} = 3 V, PS_ENB = 3 V, Lux = 0
Idle Current	I _{CC}	325	500	675	μA	V _{CC} = 3 V, PS_ENB = 0 V, Lux = 0
ALS Output						
Photo Current	I _{PH1}	15	26	–	μA	V _{CC} = 3 V, Lux = 100 ⁽¹⁾
Dark Current	I _{DARK}	–	300	–	nA	V _{CC} = 3 V, Lux = 0
Light Current Ratio		–	1.2	–	–	Incandescent / Fluorescent
Rise Time	T _r	–	5	–	ms	R ₄ = 1k Ω, Lux = 100
Fall Time	T _f	–	5	–	ms	R ₄ = 1k Ω, Lux = 100
Propagation delay	T _d	–	5	–	ms	R ₄ = 1k Ω, Lux = 100
Saturation voltage	V _{sat}	1.0	–	–	V	R ₄ = 150k Ω, V _{CC} = 3 V, Lux = 100
PS Input						
Logic High Voltage, LEDON	V _{IH}	1.8	–	–	V	
Logic High Voltage, PS_ENB	V _{IH}	1.8	–	–	V	
Logic Low Voltage, LEDON	V _{IL}	0	–	0.3	V	
Logic Low Voltage, PS_ENB	V _{IL}	0	–	0.3	V	
Logic High Input Current, LEDON	I _{IH}	–	0.1	1	μA	V _I ≥ V _{IH}
Logic High Input Current, PS_ENB	I _{IH}	–	0.1	1	μA	V _I ≥ V _{IH}
Logic Low Input Current, LEDON	I _{IL}	–	0.1	1	μA	V _I ≤ V _{IL}
Logic Low Input Current, PS_ENB	I _{IL}	–	0.1	1	μA	V _I ≤ V _{IL}
PS Output						
Analog Output	VPFILT	0.65	1.9	3.0	V	V _{CC} = 3 V, ENB = 0 V,
Digital Output Low Level, PS_DOUT	V _{OL}	0	–	0.4	V	LEDON = 10k Hz, 50% DC, 50 pulses; R ₃ = 1M ohm, C ₃ = 3.3 nF; Kodak 18% Grey card at detectable distance = 20 mm from the APDS-9800.
Crosstalk	VPFILT @ Crosstalk	0	–	0.2	V	V _{CC} = 3 V, ENB = 0 V, LEDON = 10k Hz, 50% DC, 50 pulses; R ₃ = 1M ohm, C ₃ = 3.3 nF; No blocking object
Max I _{LED} Pulse Width	Max-PW	–	120	–	μs	V _{CC} = 3 V, PS_ENB = 0 V
I _{LED} Pulse Current	I _{LED}	–	120	–	mA	V _{CC} = 3 V, R ₁ = 10 Ω
Transmitter						
Rise Time (LEDA)	T _R	–	40	–	ns	V _{CC} = 3 V, I _{LED} = 120 mA,
Fall Time (LEDA)	T _F	–	40	–	ns	Freq = 10k Hz
PS Receiver						
Rise Time(PS_DOUT)	T _R	–	1	–	μs	V _{CC} = 3 V, R ₂ = 10k Ω,
Fall Time(PS_DOUT)	T _F	–	1	–	μs	Frequency = 10k Hz
PS Hysteresis Comparator						
Hysteresis	V _{HYS}	–	40	–	mV	V _{CC} = 3 V
Threshold Voltage	V _{TH}	–	655	–	mV	V _{CC} = 3 V
PS Sunlight Cancellation						
Sun Light Illuminance	I _{sun}		100K		Lux	V _{CC} = 3 V

Note:

1. White LED is used as light source.

Typical Application Circuit

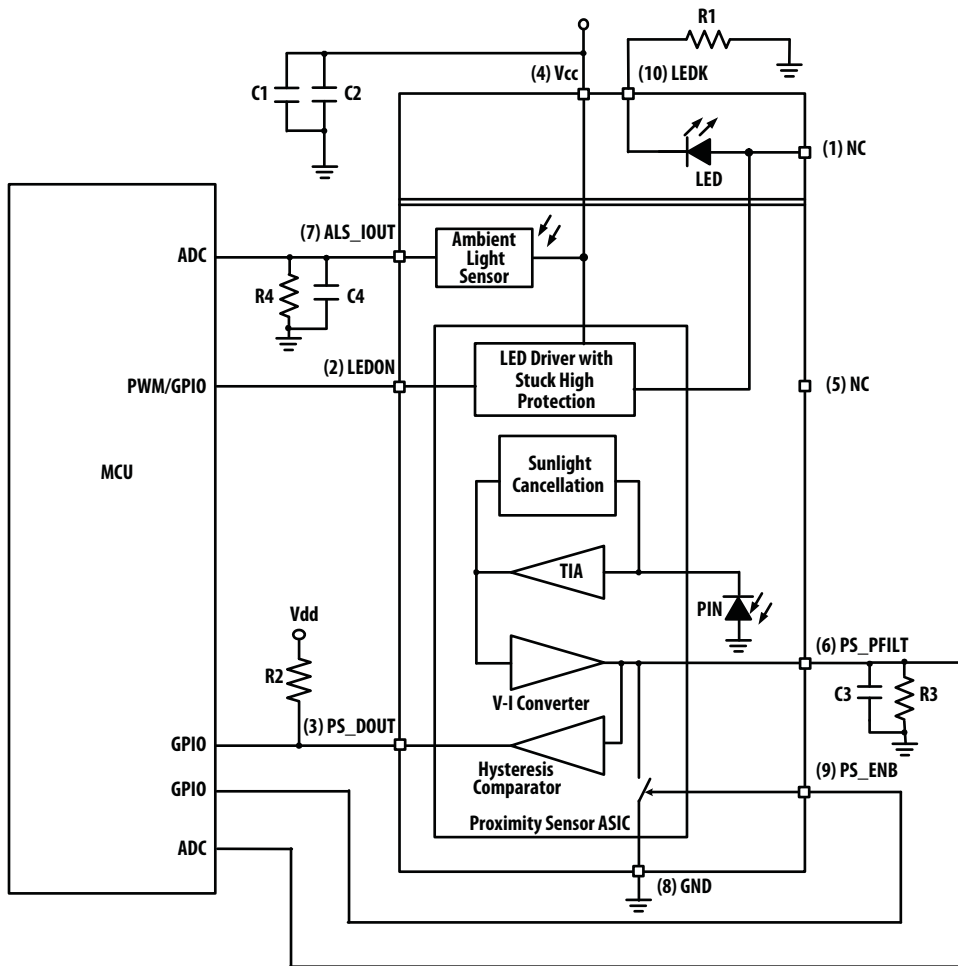

Component	Recommended Values
R1	10 Ω
R2	10k Ω
R3	1M Ω
R4	1k Ω
C1	100 nF
C2	6.8 μ F
C3	3.3 nF
C4	10 μ F

Note: Do NOT make connects to the NC pins.

Ambient Light Sensor Performance Chart

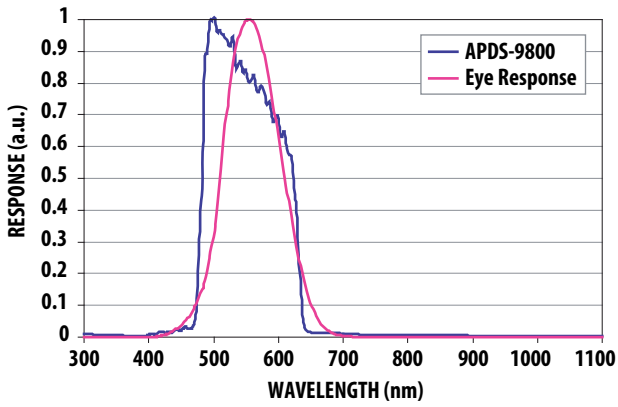

Figure 1. Normalized Sensor Spectral Response

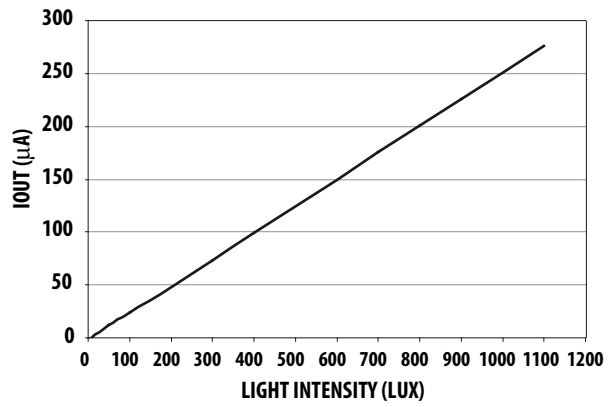

Figure 2. ALS Average Iout versus Lux (Vcc = 3.0V, T=25°C, White LED source)

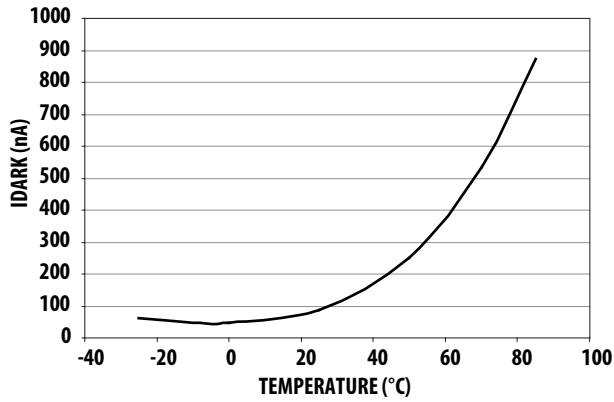

Figure 3. ALS Dark Current versus Temperature (Vcc = 3.0V)

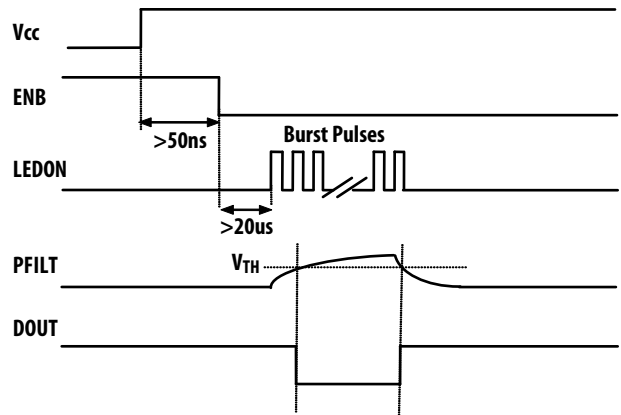

Figure 4. Proximity Sensor Typical Timing Waveforms

Proximity Sensor Performance Charts

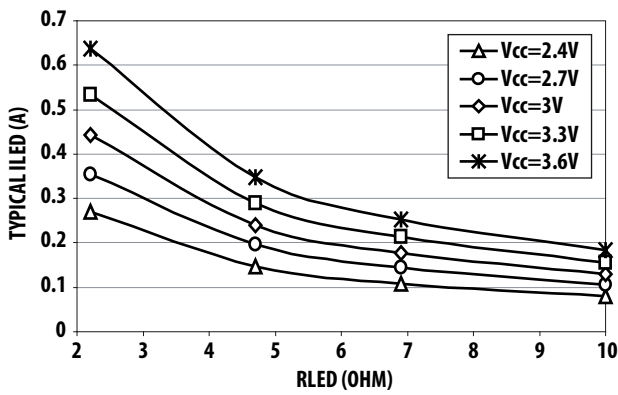

Figure 5. ILED versus RLED (TA=25°C)

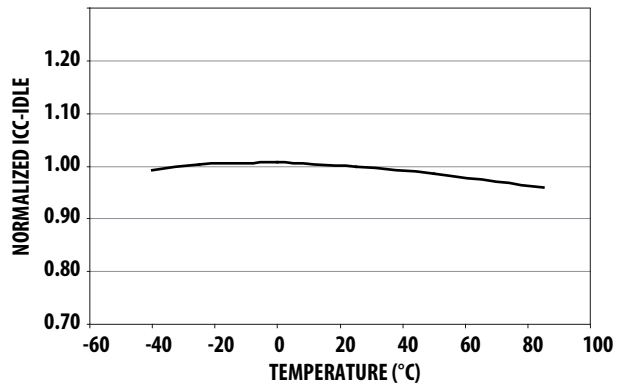
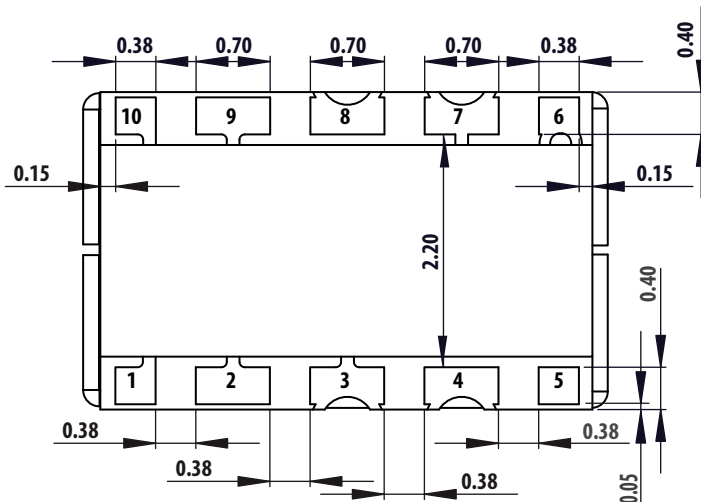
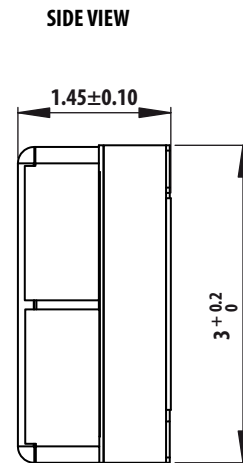
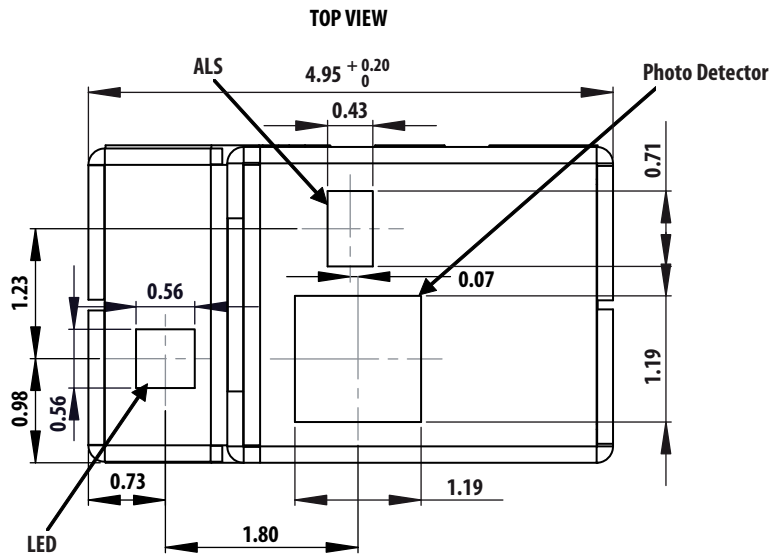

Figure 6. Normalized Idle Icc versus Temperature (Vcc=3V)

APDS-9800 Package Outline



Notes:

1. All dimensions are in millimeters.
2. Standard tolerance, unless otherwise stated:

Dimension	Standard Tolerance
Decimal	±0.5 mm
XX.X	±0.2 mm
XX.XX	±0.1 mm
All others	±0.1 mm

APDS-9800 Pin Configuration

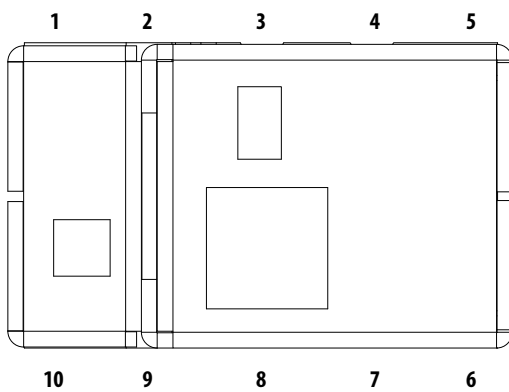

- Pin 1 : NC
- Pin 2 : LEDON
- Pin 3 : PS_DOUT
- Pin 4 : VCC Pin 5: NC
- Pin 6 : PS_PFILT
- Pin 7 : ALS_IOUT
- Pin 8 : GND
- Pin 9 : PS_ENB
- Pin 10 : LEDKTOP

Recommended Land Pattern

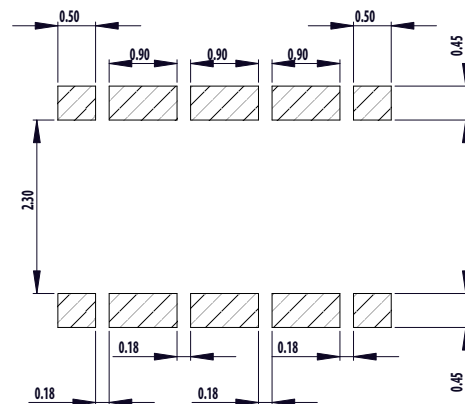

Notes:

1. All dimensions are in millimeters.
2. Do NOT connect NC pins.

APDS-9800 Tape & Reel Dimensions

Tape Dimensions

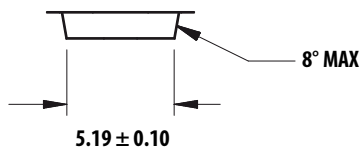
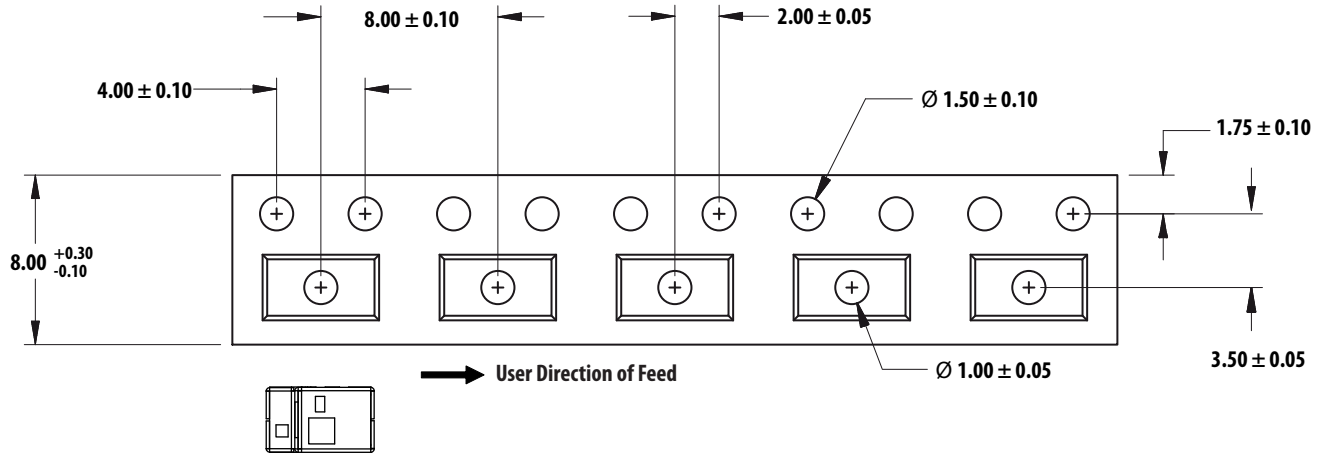

A.

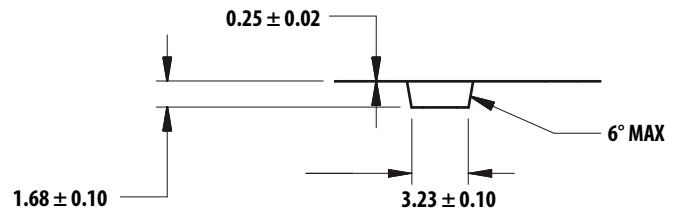

K.

B.

Reel Dimensions:

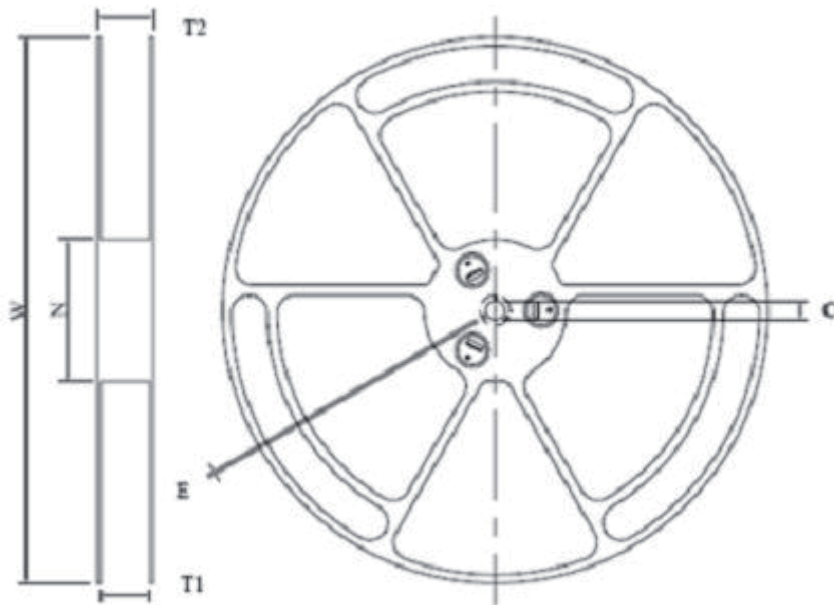

W	330.0 ± 1.5
N	100.0 ± 1.5
T1	$8.5 \pm 0.2/-0.1$
E	2.0 ± 0.5
T2	13.5 ± 0.2
C	$13.0 \pm 0.5/-0.2$

Unit: millimeter

Moisture Proof Packaging

All APDS-9800 options are shipped in a moisture proof package. Once opened, moisture absorption begins. This part is compliant to JEDEC Level 3.

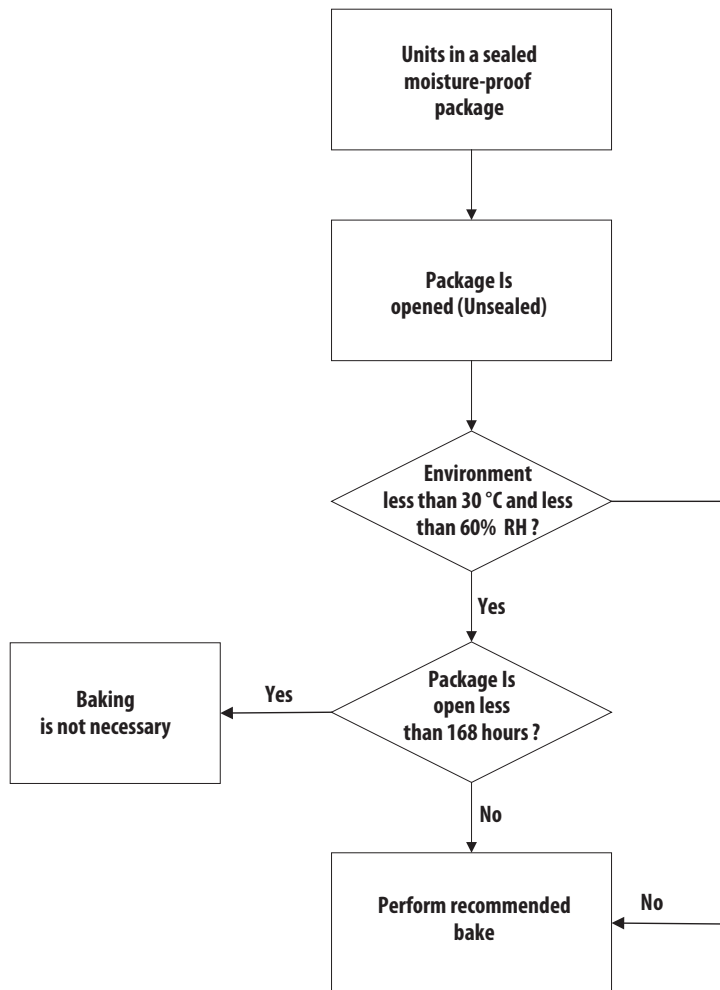

Baking Conditions:

If the parts are not stored in dry conditions, they must be baked before reflow soldering to prevent damage to the parts.

Package	Temperature	Time
In Reel	60°C	48 hours
In Bulk	100°C	4 hours

Baking should only be done once.

Recommended Storage Conditions:

Storage Temperature	10°C to 30°C
Relative Humidity	below 60% RH

Recommended Time from Unsealing to Soldering:

After removal from the bag, the parts should be soldered within 168 hours if stored at the recommended storage conditions. If times longer than 168 hours are needed, the parts must be stored in a dry box.

Recommended Reflow Profile

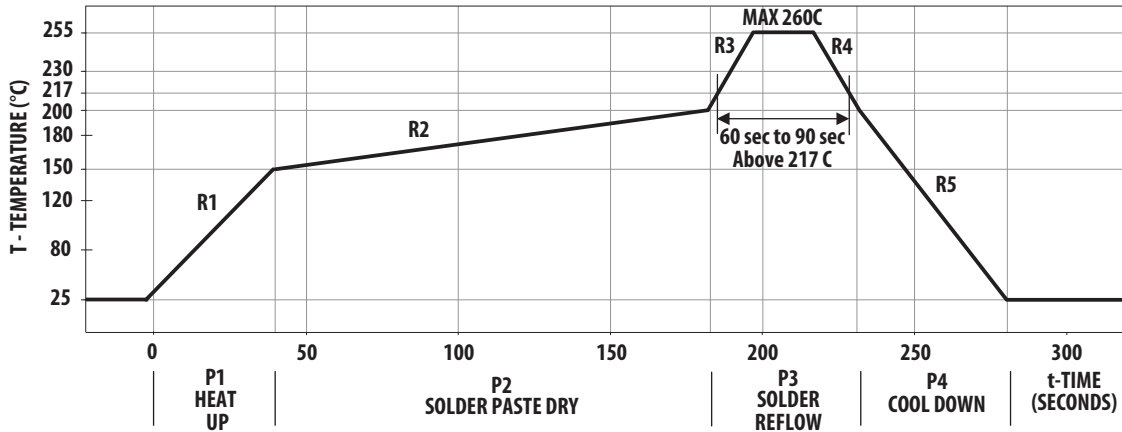

Process Zone	Symbol	ΔT	Maximum $\Delta T/\Delta$ time or Duration
Heat Up	P1, R1	25°C to 150°C	3°C/s
Solder Paste Dry	P2, R2	150°C to 200°C	100s to 180s
Solder Reflow	P3, R3 P3, R4	200°C to 260°C	3°C/s
		260°C to 200°C	-6°C/s
Cool Down	P4, R5	200°C to 25°C	-6°C/s
Time Maintained Above Liquidus Point, 217°C		> 217°C	60s to 120s
Peak Temperature		260°C	-
Time within 5°C of Actual Peak Temperature		> 255°C	20s to 40s
Time 25°C to Peak Temperature		25°C to 260°C	8minutes

The reflow profile is a straight-line representation of a nominal temperature profile for a convective reflow solder process. The temperature profile is divided into four process zones, each with different $\Delta T/\Delta$ time temperature change rates or duration. The $\Delta T/\Delta$ time rates or duration are detailed in the above table. The temperatures are measured at the component to printed circuit board connections.

In **process zone P1**, the PC board and component pins are heated to a temperature of 150°C to activate the flux in the solder paste. The temperature ramp up rate, R1, is limited to 3°C per second to allow for even heating of both the PC board and component pins.

Process zone P2 should be of sufficient time duration (100 to 180 seconds) to dry the solder paste. The temperature is raised to a level just below the liquidus point of the solder.

Process zone P3 is the solder reflow zone. In zone P3, the temperature is quickly raised above the liquidus point of solder to 260°C (500°F) for optimum results. The dwell time above the liquidus point of solder should be between 60 and 120 seconds. This is to assure proper coalescing of the solder paste into liquid solder and the formation of good solder connections. Beyond the recommended dwell time the intermetallic mm growth within the solder connections becomes excessive, resulting in the formation of weak and unreliable connections. The temperature is then rapidly reduced to a point below the solidus temperature of the solder to allow the solder within the connections to freeze solid.

Process zone P4 is the cool down after solder freeze. The cool down rate, R5, from the liquidus point of the solder to 25°C (77°F) should not exceed 6°C per second maximum. This limitation is necessary to allow the PC board and component pins to change dimensions evenly, putting minimal stresses on the component.

It is recommended to perform reflow soldering no more than twice.

Window and Light Guide Recommendations

Transparent window with IR coating (IR pass of around 90% and minimum 30% visible pass) is recommended in order to pass both visible and infrared light. The material of the window is recommended to be polycarbonate. The surface finish of the plastic should be smooth, without any texture.

The recommended plastic material for use as a window is available from Bayer AG and Bayer Antwerp N. V. (Europe), Bayer Corp.(USA) and Bayer Polymers Co., Ltd. (Thailand), as shown in Table below.

Recommended Plastic Materials

Material number	Visible light transmission*	Refractive index
Makrolon LQ2647	87%	1.587
Makrolon LQ3147	87%	1.587
Makrolon LQ3187	85%	1.587

* Transmittance of visible light will reduce if plastic window is coated with IR ink

To ensure that the performance of the APDS-9800 will not be affected by improper window design, there are some constraints on the dimensions and design of the window so that the maximum size of the window, which is placed in front of the photo light sensor, will not affect the angular response of the APDS-9800. This maximum dimension that is recommended will ensure an acceptable light reception cone.

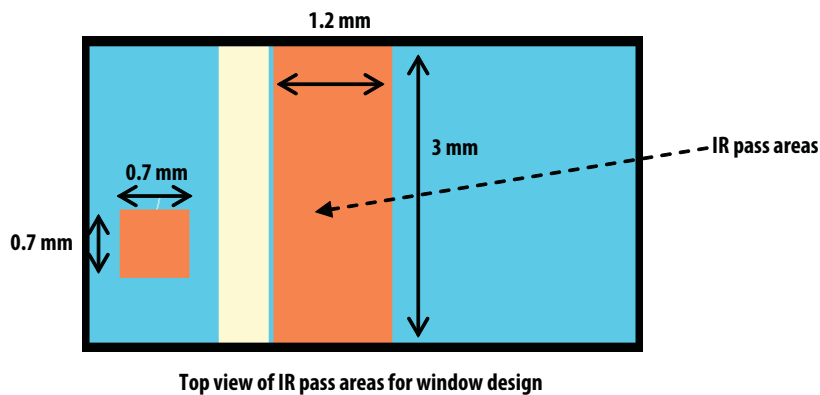
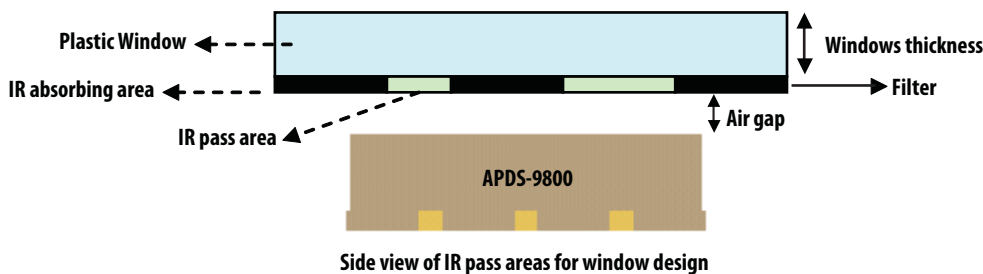

The distance between the bottom of the window and the sensor top—the air gap— should be as close as possible and not more than 0.2 mm. For optimum performance, windows thickness should be limited to not more than 0.8mm.

For product information and a complete list of distributors, please go to our web site: www.avagotech.com

Avago, Avago Technologies, and the A logo are trademarks of Avago Technologies in the United States and other countries. Data subject to change. Copyright © 2005-2011 Avago Technologies. All rights reserved. AV02-2132EN - March 21, 2011

