



Chipsmall Limited consists of a professional team with an average of over 10 year of expertise in the distribution of electronic components. Based in Hongkong, we have already established firm and mutual-benefit business relationships with customers from,Europe,America and south Asia,supplying obsolete and hard-to-find components to meet their specific needs.

With the principle of “Quality Parts,Customers Priority,Honest Operation,and Considerate Service”,our business mainly focus on the distribution of electronic components. Line cards we deal with include Microchip,ALPS,ROHM,Xilinx,Pulse,ON,Everlight and Freescale. Main products comprise IC,Modules,Potentiometer,IC Socket,Relay,Connector.Our parts cover such applications as commercial,industrial, and automotives areas.

We are looking forward to setting up business relationship with you and hope to provide you with the best service and solution. Let us make a better world for our industry!



Contact us

Tel: +86-755-8981 8866 Fax: +86-755-8427 6832

Email & Skype: info@chipsmall.com Web: www.chipsmall.com

Address: A1208, Overseas Decoration Building, #122 Zhenhua RD., Futian, Shenzhen, China





PG16/PG21/PG29/PG36 Cable Gland Instructions

To correctly use the **Cable Gland**, determine the diameter(s) of the cable(s) you want to run into the enclosure. Select an end mill (best) or drill bit of the same diameter or **0–20 thousandths larger**. See the other side for protection level based on hole diameter versus cable diameter. While the **Cable Gland** is assembled, mill or drill a hole for each cable centered on the split line in the **Split Insert**.

Note: To get the cleanest hole, do the following:

1. Use an end mill.
2. Mill from the Crown Nut side.
3. When Milling the hole, back out and clean the mill flutes frequently (every 1/4" of depth).
4. Chill down end mill before milling each hole.

To install the cable(s), unscrew the **Crown Nut** and remove the **Split Insert**. Slide the cable connector through the hole in the **Crown Nut**, then through the hole in the **Cable Gland** body. Join the 2 sides of the **Split Insert** around the cable and press the **Split Insert** back into the **Cable Gland** body. Tighten the **Crown Nut** back on the body.

And you're finished! You should now have a liquid tight seal around the cable without having to remove/replace the cable connector.

Note: For bulkhead installations, drill or punch the following mounting hole sizes:

- PG16: 23.0mm (.891") (can use a 29/32" drill)
PG21: 28.3mm (1.14") (can use a 1 1/8" drill)
PG29: 37.5mm (1.48") (can use a 1 31/64" drill)
PG36: 47.5mm (1.87") (can use a 1 7/8" drill)

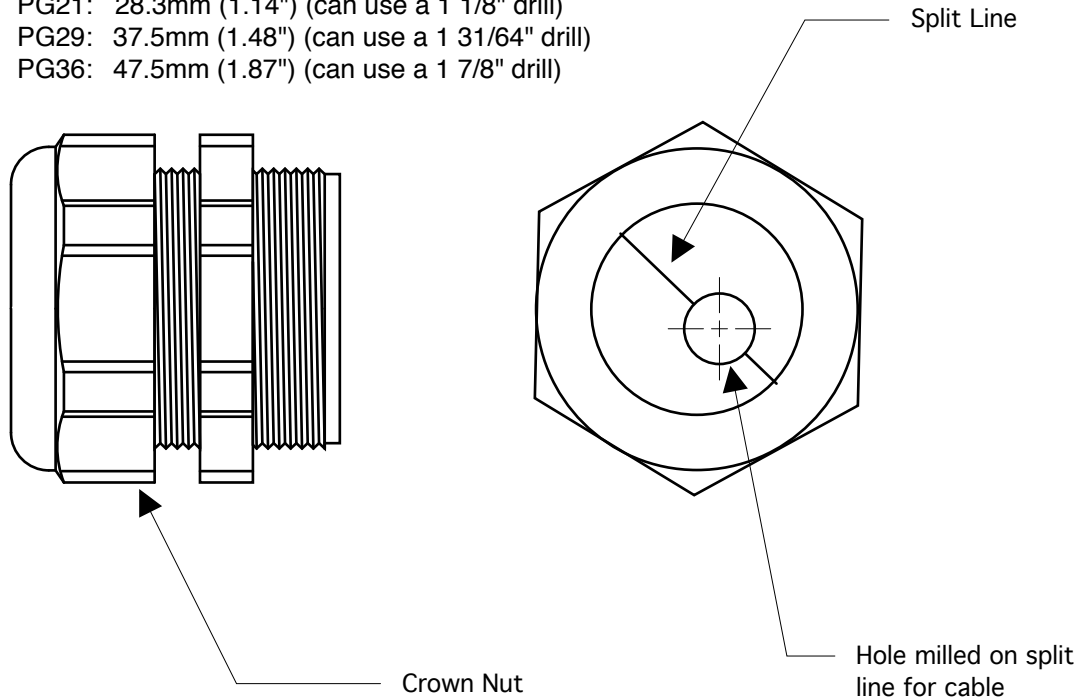

Note:

When cutting holes in the PG16s, be sure to use an end mill. Drills work very poorly in this size insert.

Replacement/Additional PG16/PG21/PG29/PG36 Cable Glands

PG16, PG21, PG29 & PG36 cable glands are available separately for running your cables through bulkheads, enclosure sides, etc.

BA Series – Standard (All cable glands are RoHS compliant)

Part Number	Description
PG16-BA	PG16 Lock ring, Polyamide Body/crown nut, TPE insert, Polyethylene seal
PG21-BA	PG21 Lock ring, Polyamide Body/crown nut, TPE insert, Polyethylene seal
PG29-BA	PG29 Lock ring, Polyamide Body/crown nut, TPE insert, Polyethylene seal
PG36-BA	PG36 Lock ring, Polyamide Body/crown nut, TPE insert, Polyethylene seal

Protection Rating: IP67; NEMA 4X
 If Cable Diameter = Insert Hole Diameter

Protection Rating: IP65; NEMA 3
 If Cable Diameter is up to 10% less than Insert Hole Diameter

Torque Recommendations 1 lbf-in. (Nm)

The listed torque values are for reference only. Due to wide range of cable insulation materials used and the varying degrees of hardness between material types, torque value for Dome Nuts can vary depending on the cable jacket's characteristics. We recommend that applied torques be determined empirically by testing the actual cable and Cord Grip used.

External Thread Sizes	Non-Metallic Cord Grips		Metallic Cord Grips
	Dome Nut	External Thread/Locknut	Dome Nut
PG16	44.0 (5.0)	44.0 (5.0)	66.0 (7.5)
PG21	66.0 (7.5)	66.0 (7.5)	88.0 (10.0)
PG29	66.0 (7.5)	66.0 (7.5)	88.0 (10.0)
PG36	66.0 (7.5)	66.0 (7.5)	88.0 (10.0)

