



Chipsmall Limited consists of a professional team with an average of over 10 year of expertise in the distribution of electronic components. Based in Hongkong, we have already established firm and mutual-benefit business relationships with customers from,Europe,America and south Asia,supplying obsolete and hard-to-find components to meet their specific needs.

With the principle of “Quality Parts,Customers Priority,Honest Operation,and Considerate Service”,our business mainly focus on the distribution of electronic components. Line cards we deal with include Microchip,ALPS,ROHM,Xilinx,Pulse,ON,Everlight and Freescale. Main products comprise IC,Modules,Potentiometer,IC Socket,Relay,Connector.Our parts cover such applications as commercial,industrial, and automotives areas.

We are looking forward to setting up business relationship with you and hope to provide you with the best service and solution. Let us make a better world for our industry!



Contact us

Tel: +86-755-8981 8866 Fax: +86-755-8427 6832

Email & Skype: info@chipsmall.com Web: www.chipsmall.com

Address: A1208, Overseas Decoration Building, #122 Zhenhua RD., Futian, Shenzhen, China





Adding Intelligence to Lighting Applications
LED Lighting Design Guide



LED Lighting Solutions

Table of Contents

LED Lighting	3	Advanced Communication Solutions for Lighting	
LED Applications	3	ZigBee® Protocol.....	15
Efficient LED Control	3	MiWi™ Protocol	15
Driving LEDs with a Charge Pump	4	MiWi™ P2P Protocol	15
MCP1252 Charge Pump Backlight		Wi-Fi Interface	15
Demonstration Board (MCP1252DM-BKLT)	4	USB Interface.....	16
Driving LEDs with a Boost Regulator	4	Ethernet Interface.....	16
MCP1650 Multiple White LED		CAN and LIN Protocols.....	16
Demonstration Board (MCP1650DM-LED2).....	5	Automotive Ambient Lighting Module	
Driving LEDs with a SEPIC Regulator.....	5	Reference Design (APGRD004)	16
MCP1650 3W White LED Demonstration Board		Temperature Sensing Solutions for	
(MCP1650DM-LED1).....	5	Power LED Applications	17
High Efficiency LED Smart Driver.....	6	Logic Output Temperature Sensors.....	17
Adding Intelligence – PIC10F Solutions	7	Resistor-Programmable Temperature Switches	17
Provide Simple Dimming Control.....	8	Using TC6501 Open Drain Output for	
Integrate Multiple Tasks –		Current Set-Point Control	18
PIC12 and PIC16 Mixed Signal Solutions	8	Using the TC6501 to Provide MCU Interrupt.....	18
Internal 5V Regulator.....	8	Fan Controller Application Using TC6502	18
Generating PWM Control Signals	9	Voltage Output Temperature Sensors.....	19
Mixed-Signal LED Drivers	10	Power LED Thermal Control Circuit Using	
MCP1630 and MCP1631 High-Speed		MCP9700 and MCP1650	19
PWM Controllers	11		
MCP1630 Boost Mode LED Driver			
Demonstration Board (MCP1630DM-LED2).....	11		
MCP1631HV Digitally Controlled Programmable			
Current Source Reference Design			
(MCP631RD-DCPC1).....	11		
Digital Control vs. Analog Control.....	12		
Low Cost Digital Control.....	12		
High Performance Digital Control	13		
Wired Communication Solutions for Lighting			
0-10V Interface.....	14		
Digitally Addressable Lighting Interface (DALI)	14		
DALI Ballast Software Library.....	14		
DMX512	14		

LED Lighting Solutions

LED Lighting

LEDs are no longer used just for providing the pretty red and green indicator lights on electronic equipment. Advances in technology have allowed LEDs to be used as practical sources of illumination. The primary benefits of LEDs are long life, durability and efficiency. When driven properly, a power LED can last tens of thousands of hours without a degradation of light output. The typical efficacy of a power LED, measured in lumens per watt, is 40-80. This is several times greater than incandescent light sources and is only exceeded by fluorescent light sources. Since the LED is a solid-state device, it can withstand shock and vibration that would damage a filament bulb.

LED Applications

The benefits of LED lighting are helpful in many types of lighting applications:

- Automotive and aircraft cabin lighting
- Automotive and aircraft instrument panel lighting
- Architectural emergency exit lighting
- Architectural color effect lighting
- Industrial and outdoor lighting
- Traffic and railway signals
- Automotive brake lights
- Dot matrix signs and video displays
- LCD display backlighting
- Personal flashlights
- Medical instrument and tool lighting
- Digital camera flash and video light

Efficient LED Control

LEDs must be driven with a source of constant current. Most LEDs have a specified current level that will achieve the maximum brightness for that LED without premature failures. An LED could be driven with a linear voltage regulator configured as a constant current source. However, this approach is not practical for higher power LEDs due to power dissipation in the regulator circuit. A switch-mode power supply (SMPS) provides a much more efficient solution to drive the LED.

An LED will have a forward voltage drop across its terminals for a given current drive level. The power supply voltage and the LED forward voltage characteristics determine the SMPS topology that is required. Multiple LEDs can be connected in series to increase the forward voltage drop at the chosen drive current level.

The SMPS circuit topologies adopted to regulate current in LED lighting applications are the same used to control voltage in a power supply application. Each type of SMPS topology has its advantages and disadvantages as presented in the table below.

This design guide presents two types of LED driver solutions. First, an analog driver IC can be used independently or together with a MCU for added intelligence. Second, the LED drive function can be integrated into the MCU application.

Literature on the Web

- AN1114 – Switch Mode Power Supply (SMPS) Topologies (Part I), DS01114
- AN1207 – Switch Mode Power Supply (SMPS) Topologies (Part II), DS01207

Common SMPS Topologies Useful for LED Lighting

Regulator Topology	V _{IN} to V _{OUT} Relationship	Complexity	Component Count	Comments
Charge Pump	$-V_{OUT} < V_{IN} < V_{OUT}$	Low	Medium	– Limited I _{OUT} range – No inductors
Buck	$V_{IN} > V_{OUT}$	Medium	Medium	– Chopped I _{IN} – High side drive
Boost	$V_{IN} < V_{OUT}$	Medium	Medium	– Extra parts needed to isolate output from input
SEPIC	$V_{OUT} < V_{IN} < V_{OUT}$	Medium	High	– Smooth I _{IN} – Multiple outputs – Two inductors
Buck-Boost	$V_{OUT} < V_{IN} < V_{OUT}$	Medium	Medium	– Single inductor – Up to four switches
Flyback	Depends on transformer	Medium	Medium	– Transformer can provide electrical isolation – Multiple outputs possible

LED Lighting Solutions

Driving LEDs with a Charge Pump

A charge pump power supply does not have inductors that are required in other SMPS topologies. This provides a more compact and less expensive circuit. The downside is that charge pumps cannot supply large amounts of current compared to the other topologies. Charge pump circuits are most useful for backlighting applications. Common applications include PCs, LCD displays and automotive instrumentation.

MCP1252 Charge Pump Backlight Demonstration Board (MCP1252DM-BKLT)



Demonstrates the use of a charge pump device in an LED application and acts as a platform to evaluate the MCP1252 device in general. Light intensity is controlled uniformly through the use of ballast resistors. A PIC10F206 MCU

provides an enable signal to the MCP1252 and accepts a push-button input that allows the white LEDs to be adjusted to five different light intensities.

Literature on the Web

- MCP1252/3 Data Sheet, DS21572
- MCP1252 Charge Pump Backlight Demo Board User's Guide, DS51551
- MCP1252/3 Evaluation Kit User's Guide, DS51313
- DG10 – Power Solutions Design Guide, DS21913

Driving LEDs with a Boost Regulator

A boost regulator topology is used when the output voltage of the converter must be equal to or greater than the input voltage. A boost regulator is useful for driving a chain of LEDs connected in series. It is beneficial to drive multiple LEDs in series. This ensures that all LEDs receive the same amount of current and will have the same brightness level. Using a coupled inductor in the boost circuit reducing the switching voltage requirements of the MOSFET switch.

The MCP1640 synchronous boost regulator can provide a stable operating voltage for an LED from a single cell alkaline battery.

The MCP1650 Boost Regulator uses an external switch so that it can be used for any type of load. An additional advantage of the MCP1650 in battery applications is the Gated Oscillator Architecture which provides 2 duty cycles reducing high-peak inductor current and output ripple voltages. Input voltages above 3.8V engage a 56% duty cycle and an 80% duty cycle when the input voltage drops below 3.8V, extending battery life in these applications.

MCP1640 Single Cell Synchronous Boost Regulator

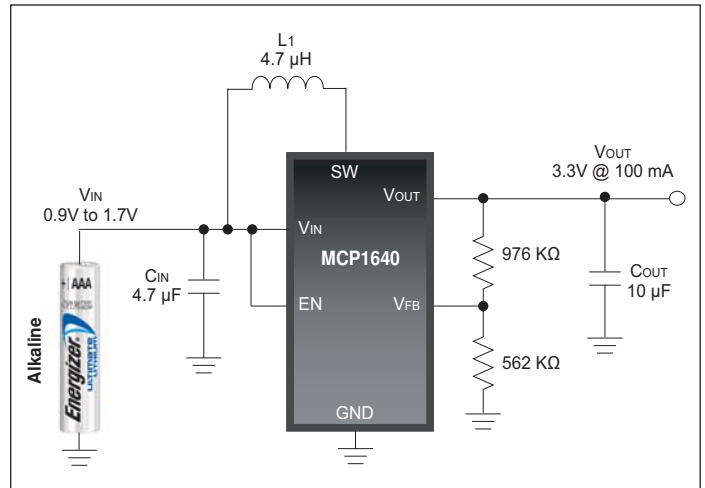

Charge Pump LED Driver Using the MCP1252

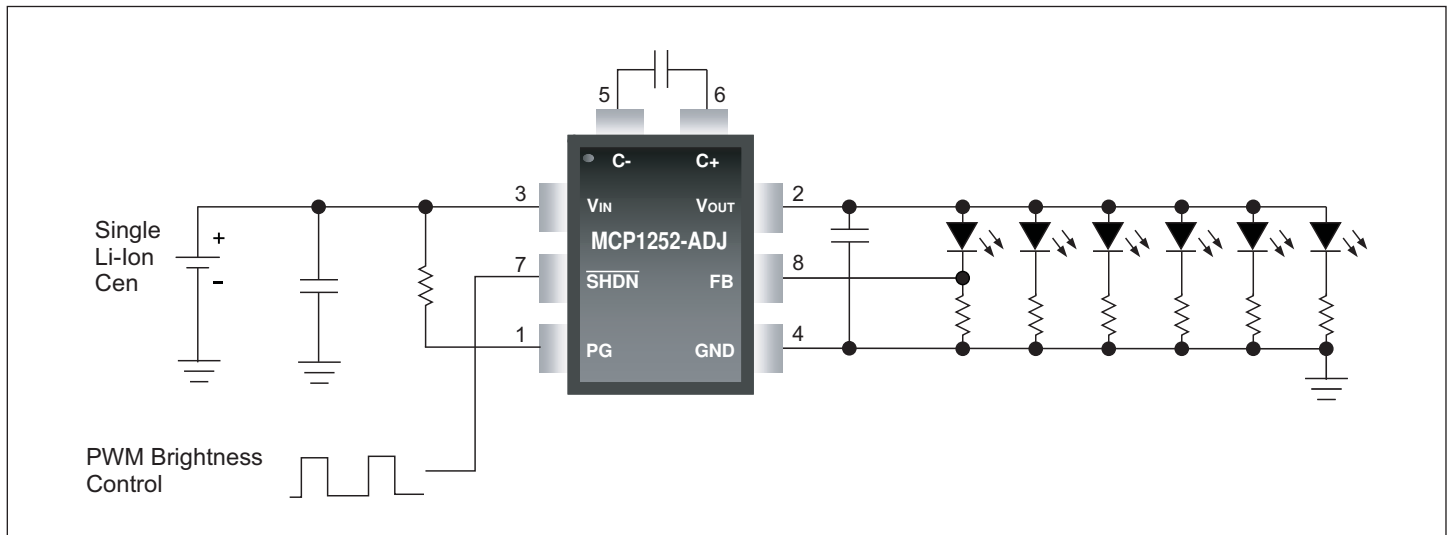

LED Lighting Solutions

MCP1650 Multiple White LED Demonstration Board (MCP1650DM-LED2)



The MCP1650 Multiple White LED Demo Board uses the MCP1650 IC to power the nine white LEDs which are connected in series. A PIC10F202 microcontroller in a SOT-23 6-pin package is used to provide the PWM signal to the MCP1650. It also accepts a push button input that allows the user to adjust the white LEDs to three different intensities of 100%, 50% and 25%.

Literature on the Web

- MCP1640/B/C/D Data Sheet, DS22234
- MCP1650/51/52/53 Data Sheet, DS21876
- MCP1650 Multiple White LED Demo Board User's Guide, DS51586
- AN948 – Efficiently Powering Nine White LEDs Using the MCP1650, DS00948
- AN980 – Designing a Boost-Switching Regulator with the MCP1650, DS00980
- DG10 – Power Solutions Design Guide, DS21913

Driving LEDs with a SEPIC Regulator

The Single-Ended Primary Inductance Converter (SEPIC) regulator topology uses an additional inductor, but provides the following advantages for battery powered applications:

- The converter can buck or boost as the input voltage changes.
- The circuit topology provides inherent short-circuit protection due to the use of a coupling capacitor.

MCP1650 3W White LED Demonstration Board (MCP1650DM-LED1)



Demonstrates the MCP165X Boost Controller product family in a battery-powered white LED application with an input voltage range of 2.0V to 4.5V.

Literature on the Web

- MCP1650 3W White LED Demo Board User's Guide, DS51513

Battery Operated Boost LED Driver Example Using the MCP1650

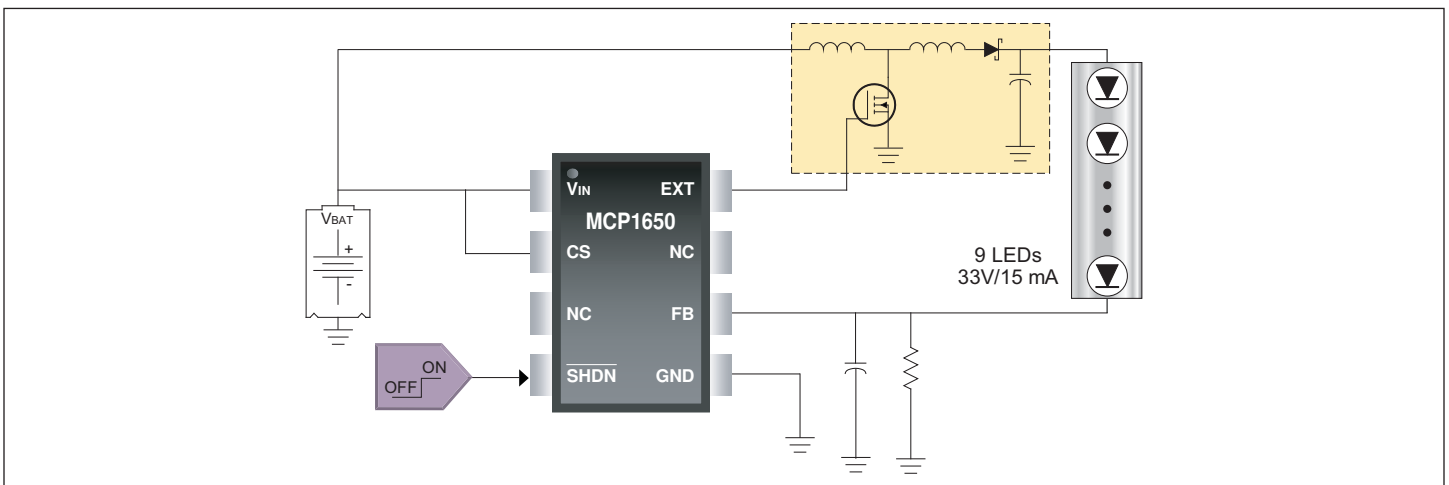

Battery Input to 3.6V 3W LED Driver (SEPIC Converter)

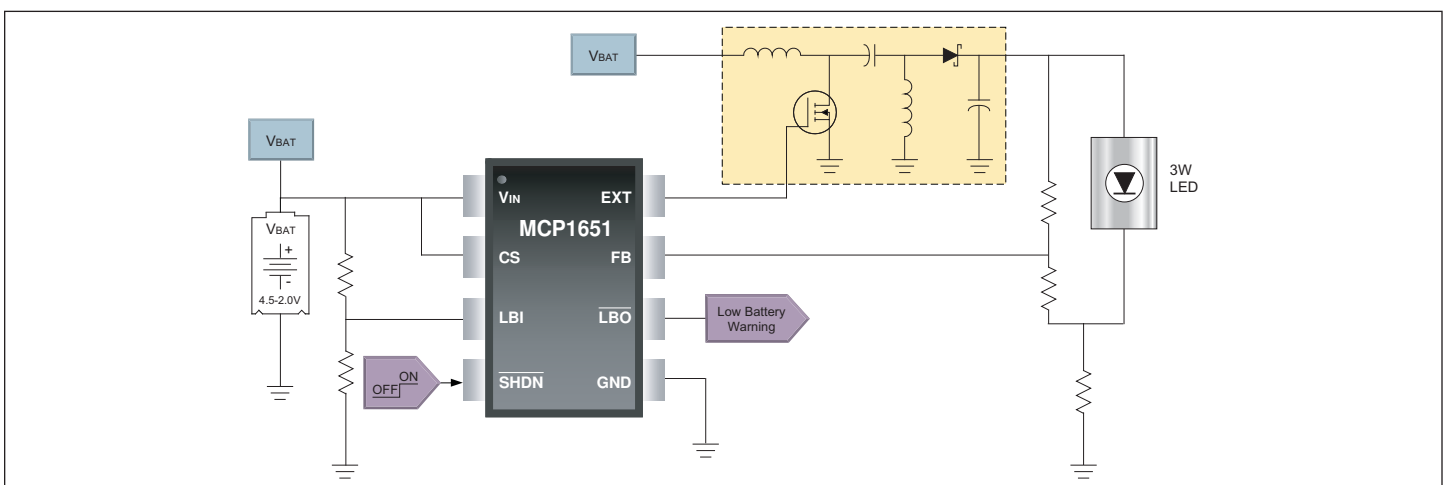

LED Lighting Solutions

High Efficiency LED Smart Driver

9-13 volt systems easily adapt to a Smart Driver Circuit to drive High Power LEDs using the MCP1702, MCP1652 and a PIC10F202. The MCP1702 directly connected to the 12 volt source creates a 5 volt bias supply capable of delivering 250 mA to the intelligent boost control circuit. The LEDs are powered by the source voltage boosted by the MCP1652, minimizing the current requirements for the 5V power system. A PIC10F202 adds intelligence to the circuit providing a means for thermal protection, load open and short circuit protection as well as the capability of a user interface to control dimming and other features.

Low Battery Detect enables the designer to determine a trip point for a low battery condition to make “smart” adjustments to the circuit function with the PIC10F202. The Power Good Indication enables the designer to determine when output voltage conditions are correct.

LED Smart Driver with 12V Input

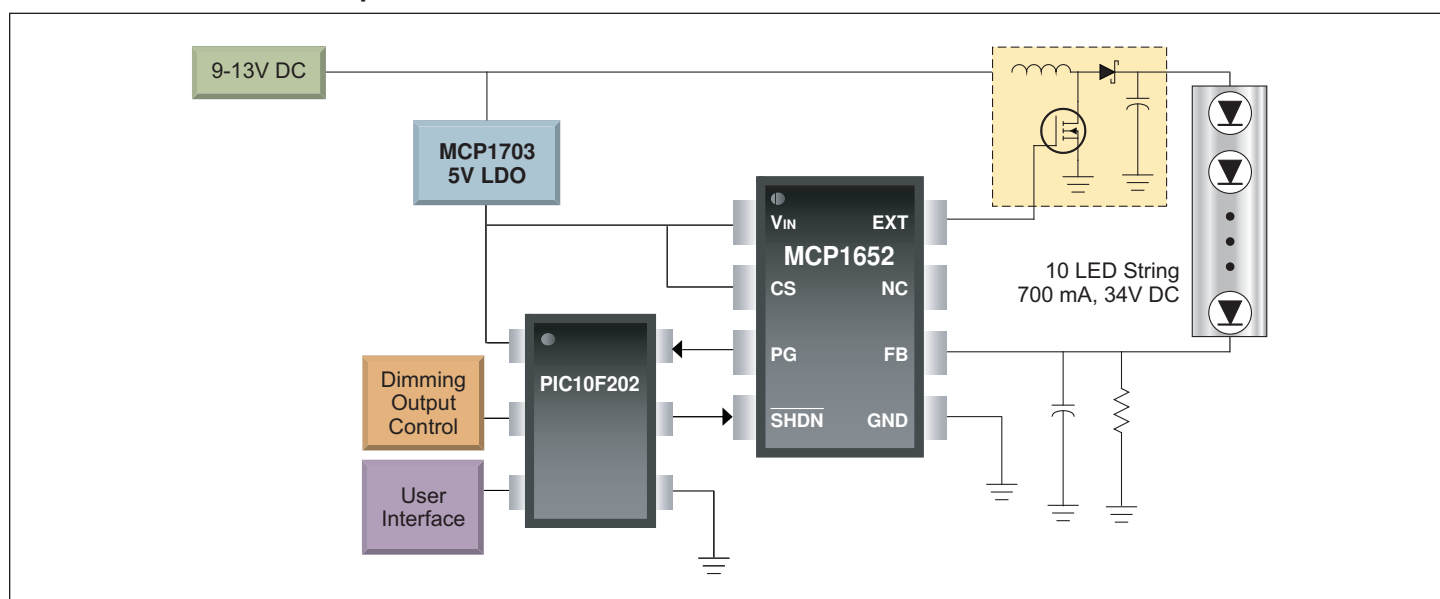

Literature on the Web

- MCP1650/51/52/53 Data Sheet, DS21876
- AN980 – Designing a Boost-Switching Regulator with the MCP1650, DS00980
- DG10 – Power Solutions Design Guide, DS21913

MCP165X Driver Devices

Device	Special Features	Package
MCP1650	Standard Device	8-Pin MSOP
MCP1651	Low Battery Detect	8-Pin MSOP
MCP1652	Power Good Indication	8-Pin MSOP
MCP1653	Low Battery Detect and Power Good Indication	10-Pin MSOP

LED Lighting Solutions

Adding Intelligence – PIC10F Solutions



LED lighting applications can benefit from the intelligence of a MCU. The MCU can be used for a variety of tasks, including the user interface, communication, battery status monitoring and temperature measurement.





The addition of a MCU to a design does not have to be complicated, space consuming, or expensive. Microchip offers the PIC10F family of MCUs with devices that have 6 pins in a space saving SOT-23 or 2 x 3 mm DFN style package. The oscillator and reset circuitry are inside the device. Connect power, ground, and you get four I/O pins that can be programmed to do anything you want. It's as simple as that.

The PIC10F pins can be used as analog or digital pins. Two devices in the PIC10F family have analog comparator modules. Two PIC10F devices are available with an 8-bit analog to digital converter (ADC). There are only 33 assembly instructions to learn in order to write code for the PIC10F. There are also C compilers available for the PIC10F family, if you prefer to write in a high-level language.

PIC10F 6-Pin Microcontroller Family

Device	Flash Program Memory Words	Data RAM Bytes	8-Bit Timer	Analog Comparator Module	8-bit ADC Module
PIC10F200	256	16	Yes	–	–
PIC10F202	512	24	Yes	–	–
PIC10F204	256	16	Yes	Yes	–
PIC10F206	512	24	Yes	Yes	–
PIC10F220	256	16	Yes	–	Yes
PIC10F222	512	24	Yes	–	Yes

Package Comparison SOT-23 vs. MSOP and SOIC

			
8-TDFN (MC/MNY) 2 x 3 mm	6-SOT (OT) 3 x 3 mm PIC10F2XX	8-MSOP (MS) 3 x 5 mm	8-SOIC (SN) 5 x 6 mm

Shown approximate size.

Provide Simple Dimming Control

One application for a MCU in LED lighting is brightness control. A power LED can be dimmed by reducing the drive current. However, this is not the most efficient way to control the brightness of a LED. A power LED provides the best efficiency at the maximum rated drive current. Better efficiency can be obtained by turning the LED on and off using a low frequency PWM signal. The PWM signal is connected to the enable input of the SMPS control IC. The LED is always driven at the maximum current level when it is on.

The MCP1650 Multiple White LED Demo Board and the MCP1650 3W White LED Demo Board both take advantage of the 6-pin PIC10F206 MCU (see pages 5-7 for more information). The PIC10F206 device provides the user button interface and generates the PWM control signal for the SMPS IC. The PIC10F206 has an internal oscillator and reset circuit, so no external circuitry is required. The PIC10F206 device could also be used to linearize the brightness control or monitor battery status in these applications.

LED Lighting Solutions

Integrate Multiple Tasks – PIC12 and PIC16 Mixed Signal Solutions

The LED current drive function can be integrated with other tasks on the same MCU. Members of the PIC12F and PIC16F device families provide the next step up from the PIC10F family and facilitate highly integrated mixed signal designs in 8, 14 and 20-pin package options. The available peripherals in this series of devices include:

- Shunt Voltage Regulator
- Comparators
- Op Amps
- ADC
- Voltage Reference
- Hardware PWM (Digital Timebase or SR Latch)

These peripherals allow external power circuits to be directly controlled by the MCU. For a LED driver application, the analog peripherals can be configured and interconnected in software to provide constant current regulation. This leaves the CPU free to run other tasks such as communication, dimming control or fault detection.

Internal 5V Regulator

The internal shunt voltage regulator option allows the MCU to be operated from a higher voltage DC bus making it useful in AC line powered applications. Only a series resistor is required between the power supply and the device V_{DD} pin.

Devices with an “HV” designator in the part number have an internal regulator.

8, 14 and 20-Pin PIC® Microcontroller Mixed Signal Features

Device	Pins	Voltage Reference	Analog Comparator	Op Amps	ADC	Digital PWM Module	PWM SR Latch
PIC12F609/PIC12HV609	8	–	1	–	–	–	–
PIC12F615/PIC12HV615	8	–	1	–	10-bit	1	–
PIC12F1822	8	Yes	1	–	10-bit	1	1
PIC16F610/PIC12HV610	14	–	2	–	–	–	1
PIC16F616/PIC16HV616	14	–	2	–	10-bit	1	1
PIC16F785/PIC16HV785	20	Yes	2	2	10-bit	1	2
PIC16F1828	20	Yes	2	–	10-bit	4	1

Note: ‘HV’ part numbers have internal shunt voltage regulator.

Easy Migration

The 8, 14 and 20-pin devices in the PIC12F and PIC16F families have compatible pin-outs for upward and downward migration. Common connections such as power and ground are located in the same positions on the package footprint so that an 8-pin design can easily be expanded to a 14 or 20-pin design.

Literature on the Web

- AN1035 – Designing with HV Microcontrollers, DS01035
- PIC16F785/HV785 Device Data Sheet, DS41249

Web Links

www.microchip.com/8bit

Compatible Pinouts Provide Migration Options

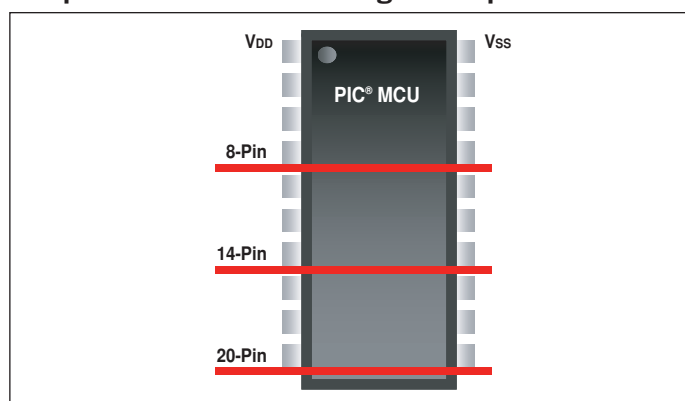

LED Lighting Solutions

Generating PWM Control Signals

There are multiple ways to generate PWM control signals to control power circuits.

- Devices with the Capture-Compare-PWM (CCP) module can generate PWM signals to control power circuits using an on-chip digital timebase. The signal pulse width is controlled by the MCU clock and a duty cycle register.
- The Enhanced CCP (ECCP) module allows one PWM signal to control 2 or 4 output pins for half-bridge or H-bridge control, respectively.
- Devices that have a comparator and the ECCP module can use the comparator signal to control the turn-off time of the PWM signal.
- Devices with comparators and a PWM SR latch can use comparator signals and/or clock pulses to turn the latch output on and off.

- An external PWM peripheral IC may be used. This option is useful when multiple high speed PWM channels are required.
- PWM signals can be generated using software and I/O pins. This option is less costly when PWM frequency and duty cycle resolution requirements are not too high.

A PIC microcontroller with an on-chip comparator such as the PIC12HF609 can be used to implement a simple LED driver. The PIC12HV609 adds an internal regulator, allowing operation from a DC bus higher than 5 volts.

Literature on the Web

- AN874 – Buck Configuration High-Power LED Driver, DS00874
- AN1074 – Software PWM Generation for LED Dimming and RGB Color Applications, DS01074

Buck LED Driver Using a Comparator

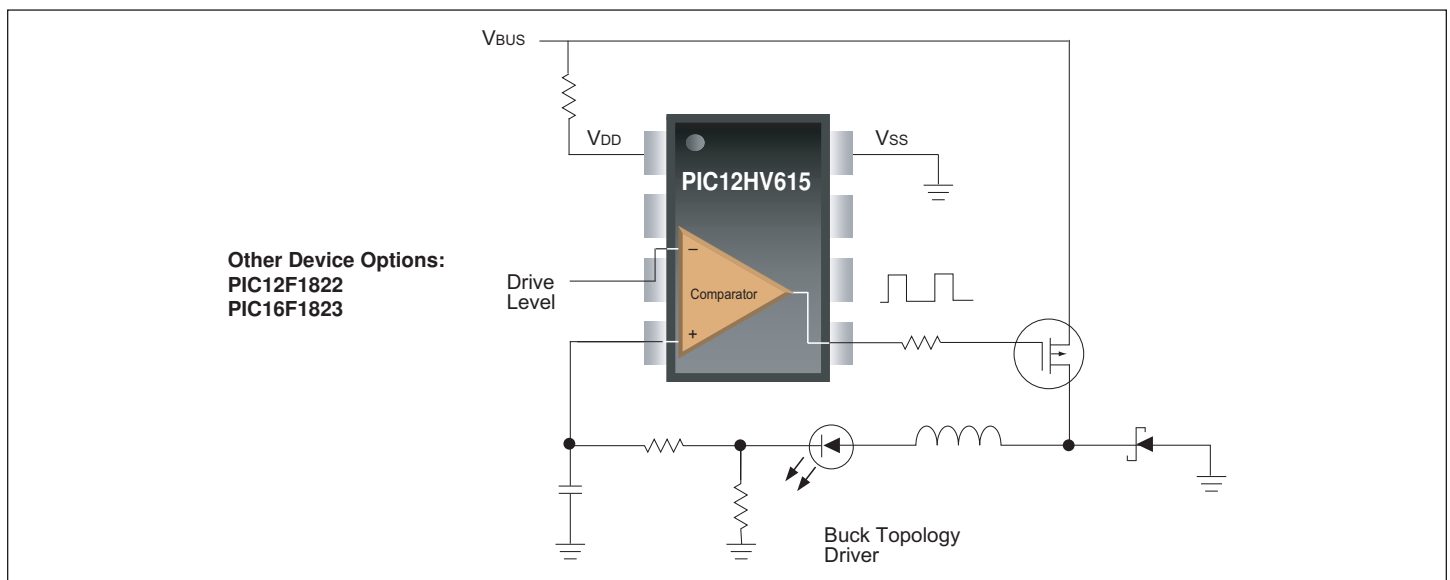

RGB Color LED Application Using PIC12HV615

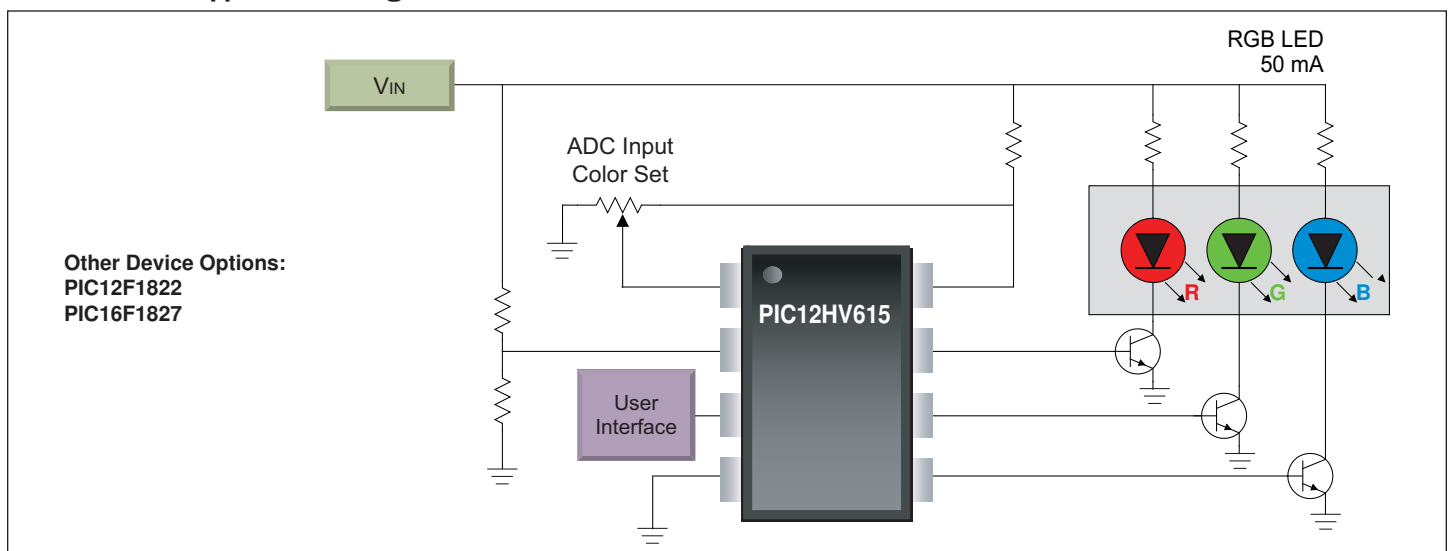

LED Lighting Solutions

Mixed-Signal LED Drivers

Some devices, such as the PIC16F616, have a SR latch module that can be used in many different ways along with the comparators and other digital signal events. Events such as clock pulses or comparator signals can be programmed to set or reset the SR latch. These programming options allow almost any kind of control signal to be generated.

The PIC16F785 has two on-chip op amps, two on-chip comparators, two SR latch PWM modules and an adjustable voltage reference. This combination of peripherals can be digitally configured to implement a wide variety of SMPS circuit topologies.

Literature on the Web

- AN1035 – Designing with HV Microcontrollers DS01035
- AN1047 – Buck-Boost LED Driver Using the PIC16F785 MCU, DS01047
- AN1271 – Offline Power Converter for High Brightness LEDs Using the PIC16HV785 Microcontroller, DS01271
- PIC16F785/HV785 Device Data Sheet, DS41249

PIC16HV785 Boost LED Driver Application

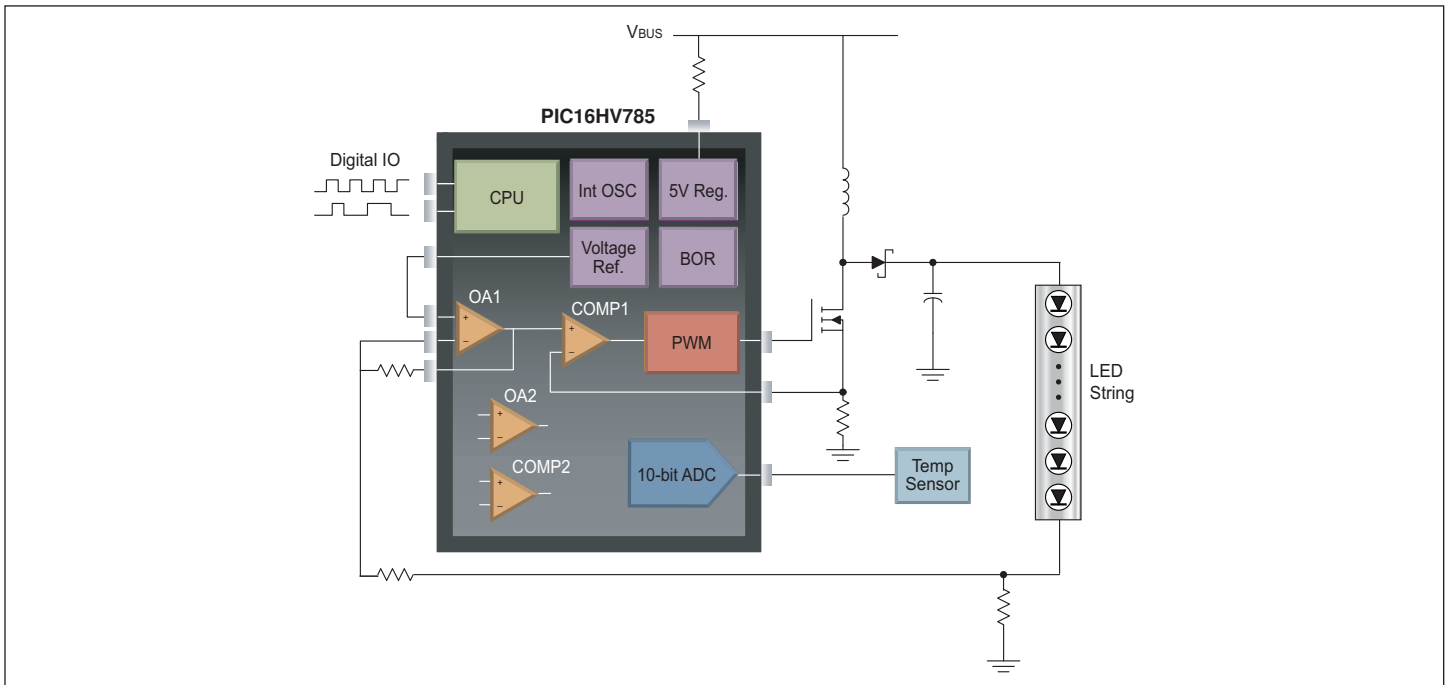

PIC16HV785 Flyback Converter with PFC and Dimming Control

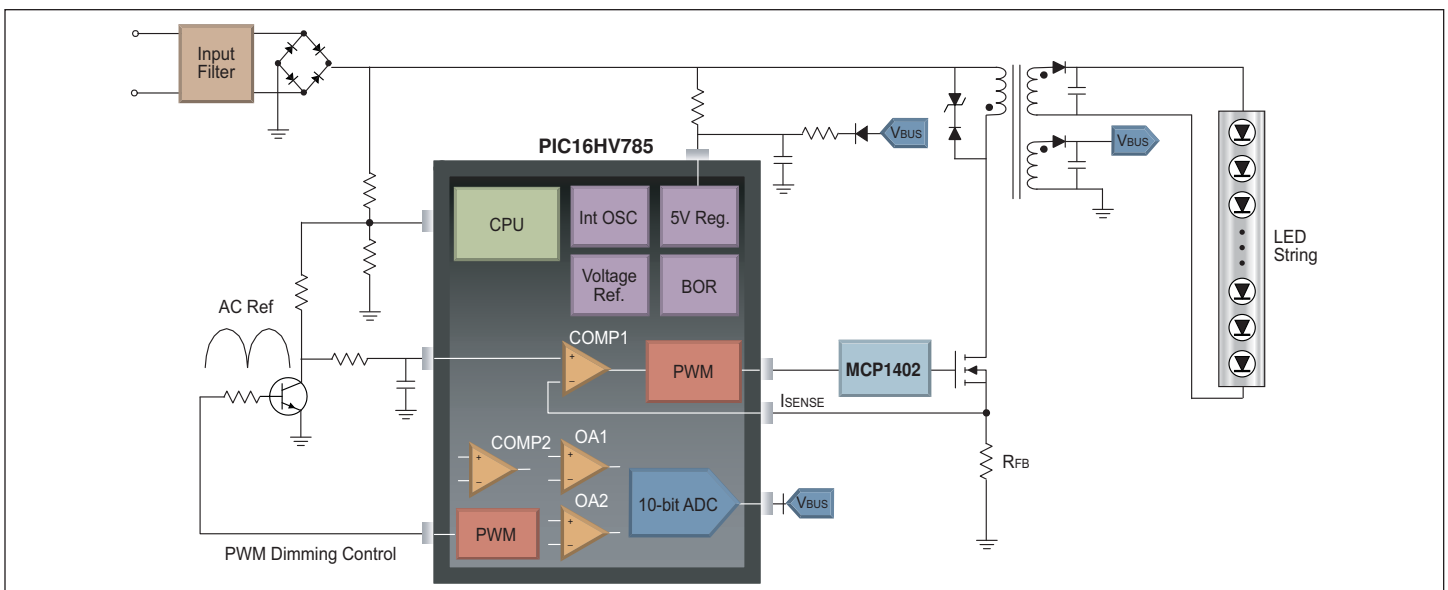

LED Lighting Solutions

MCP1630 and MCP1631 High-Speed PWM Controllers

The MCP1630 and MCP1631 offer another method that can be used to generate high speed PWM signals for high power LED drivers. The MCP1630 is an 8-pin device that contains the components needed to generate an analog PWM control loop, including an error amplifier, comparator and a high current output pin to drive a power transistor.

The MCP1630 is designed to be used with a MCU that provides a reference clock source. The MCU controls the PWM frequency and maximum duty cycle. The switching frequency can be up to 1 MHz, depending on the application requirements. The MCU can also control the reference input for the error amplifier when dimming or soft start functions are required. Multiple MCP1630 devices can be attached to a MCU to support multiple power channels.

The MCP1630 can be used to solve advanced power supply issues. When multiple MCP1630 devices are used, phase offsets can be applied to each clock input to reduce bus current ripple. For applications that are sensitive to EMI, dithering can be applied to the clock signal to reduce radiated energy at a given frequency.

The MCP1631 is a 20-pin device which, in addition to the MCP1630 includes an internal 5V or 3.3V regulator, shutdown control, overvoltage protection, oscillator disable and 1x and 10x gain amplifiers.

MCP1630 Boost Mode LED Driver

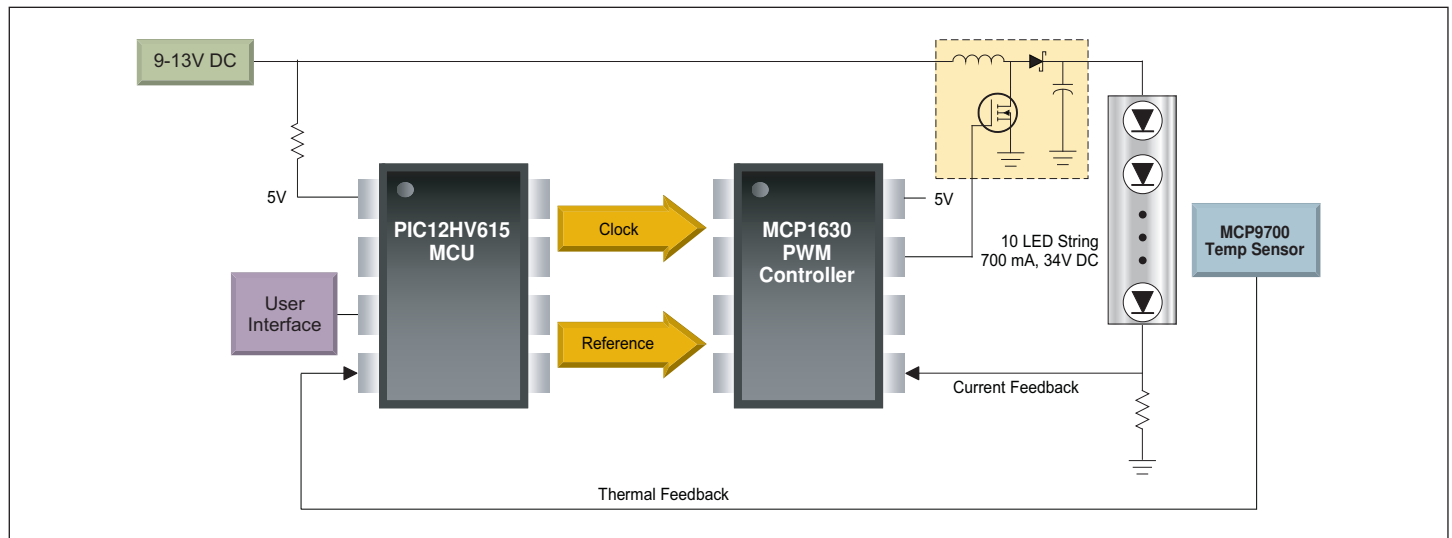

MCP1630 Boost Mode LED Driver Demonstration Board (MCP1630DM-LED2)



This demo board is a step-up, switch-mode, DC-DC converter used for power LED applications. The demo board provides a 350 mA or 700 mA constant current source with a jumper selection. The input operating voltage range is 9-16 VDC and the board can supply up to 30W to a string of power LEDs.

MCP1631HV Digitally Controlled Programmable Current Source Reference Design (MCP631RD-DCPC1)



This board provides a SEPIC DC-DC converter for power LED and battery charging applications. The input voltage range is 3.5-16 VDC and the maximum power output is 8.5W.

Literature on the Web

- MCP1630/MCP1630V Device Data Sheet, DS21896
- MCP1631 Device Data Sheet, DS22063

LED Lighting Solutions

Digital Control vs. Analog Control

LEDs can be driven with a fully digital control loop. Instead of measuring the LED current with an op amp or comparator circuit, the LED current is sampled using an ADC. Some type of digital algorithm replaces the analog control loop. A proportional-integral-derivative (PID) control algorithm is commonly used because it has software coefficients that can readily be adjusted to affect the controller behavior. A digital PWM peripheral is used to drive the LED. The digital algorithm computes an output based on its inputs and provides the duty cycle for the PWM peripheral.

Literature on the Web

- AN1138 – A Digital Constant Current Power LED Driver, DS01138

Low Cost Digital Control

Some power supply applications require fast dynamic response to compensate for load changes. In these applications, a fast ADC and fast calculation performance are required. However, a LED provides a stable load for a constant-current power supply. Therefore, a fast ADC and fast processing power are not always required to implement a digital control loop for a LED driver application.

A low-cost device in the PIC12F or PIC16F family with a CCP peripheral and an ADC can be used to implement a LED driver using digital control. The CCP peripheral is used in PWM mode to control the power supply circuit. Operating from the internal 8 MHz device oscillator, the CCP can provide PWM frequencies above 100 KHz to keep power component sizes small. Since the LED provides a constant load, it is sufficient to sample the output current and adjust the PWM duty cycle at a much lower rate. A sample rate of 1000 Hz is ideal for many applications.

Comparison of Digital Control vs. Analog Control Functions

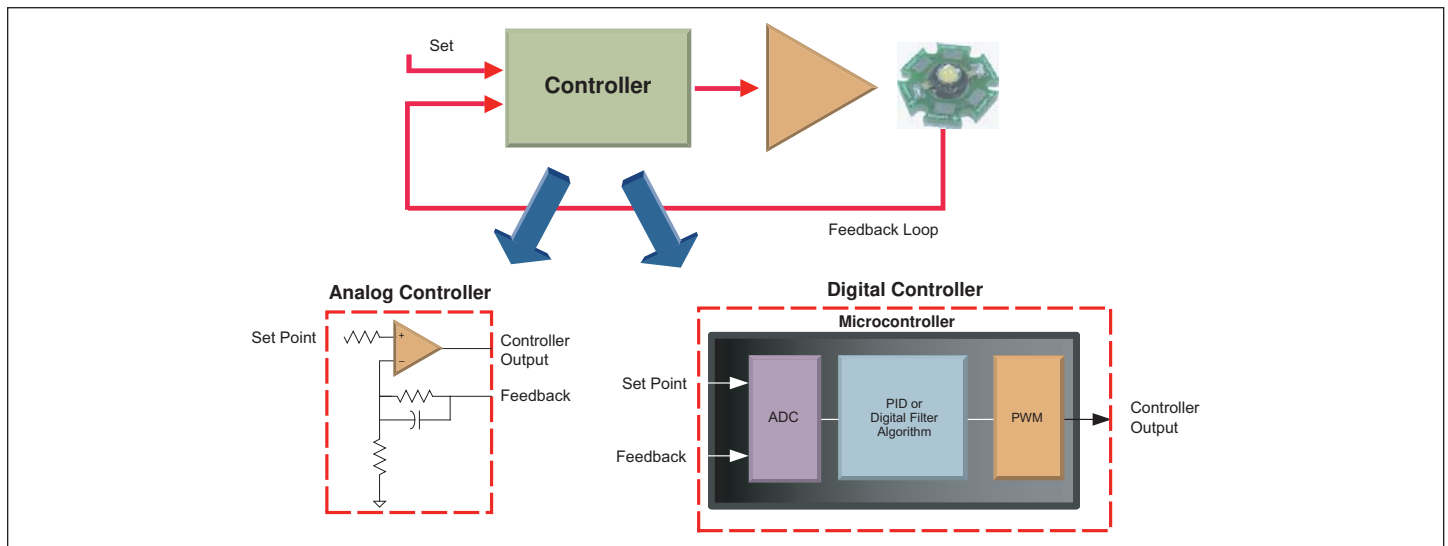

PIC12HV615 Buck LED Driver with Digital Control

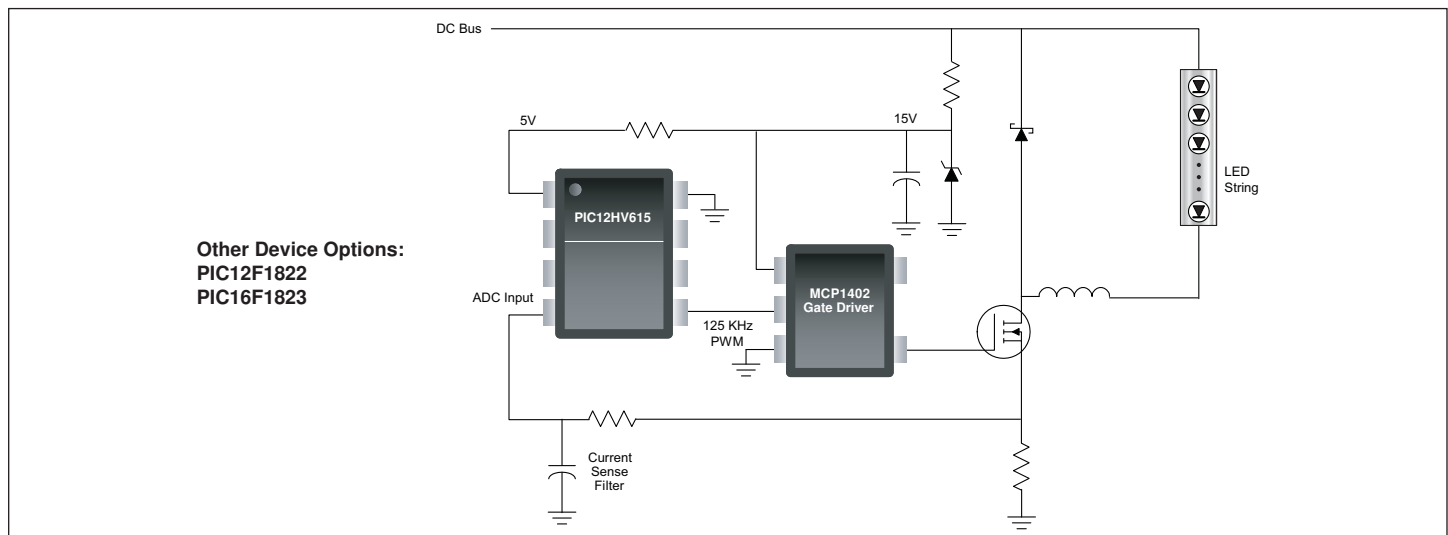

LED Lighting Solutions

High Performance Digital Control

Devices in the PIC18F, PIC24 and dsPIC33F families offer 8-bit and 16-bit solutions for fast calculation of digital control loops. In addition, these families have device variants with fast ADC peripherals and specialized PWM modules that are optimized for power control applications.

A selection of devices for digital power control is shown in the table below. There are many other Microchip devices that could be used, but these devices represent low-cost and small package choices.

Devices in the PIC18F family have an 8-bit CPU with a hardware multiplier. The PIC18 is a good choice for moderate control loop rates (1-10 KHz). Devices in the dsPIC33F family have a 16-bit CPU with DSP resources. This family is a good choice if you need to execute multiple control loops at a faster rate. Devices in the PIC24 family offer an intermediate solution with 16-bit calculation performance.

The dsPIC33FJ06GS202 device has a Power Supply PWM module that can generate high switching frequencies with very fine edge resolution. This PWM module can also generate phase shifted PWM signals for advanced power supply applications.

The 28-pin dsPIC33FJ06GS202 device can provide a highly integrated solution for LED lighting applications. The PWM peripheral can drive 3 strings of LEDs, replacing 3 separate analog control ICs. Furthermore, there are resources left over for active power factor correction (PFC) and digital communications.

LED Lighting Development Kit Reference Design

The LED Lighting Development Kit demonstrates the capabilities of Microchips “GS” series of dsPIC Digital Signal Controllers (DSC) in High Brightness (HB) LED applications. More information is available at: www.microchip.com/LED.

Web Links

www.microchip.com/smcs
www.microchip.com/pic24
www.microchip.com/pic18

Selected Devices for Digital Power Control

Device	Pins	Architecture	ADC	PWM
PIC18F23K22	28	8-bit MCU	10-bit, 100 KSPS	3 Enhanced, 2 Standard
PIC24FJ16GA002	28	16-bit MCU	10-bit, 500 KSPS	5 Standard
dsPIC33FJ06GS202	28	16-bit DSC	10-bit, 2 MSPS	4 Power Supply

Multiple LED Driver Application with PFC

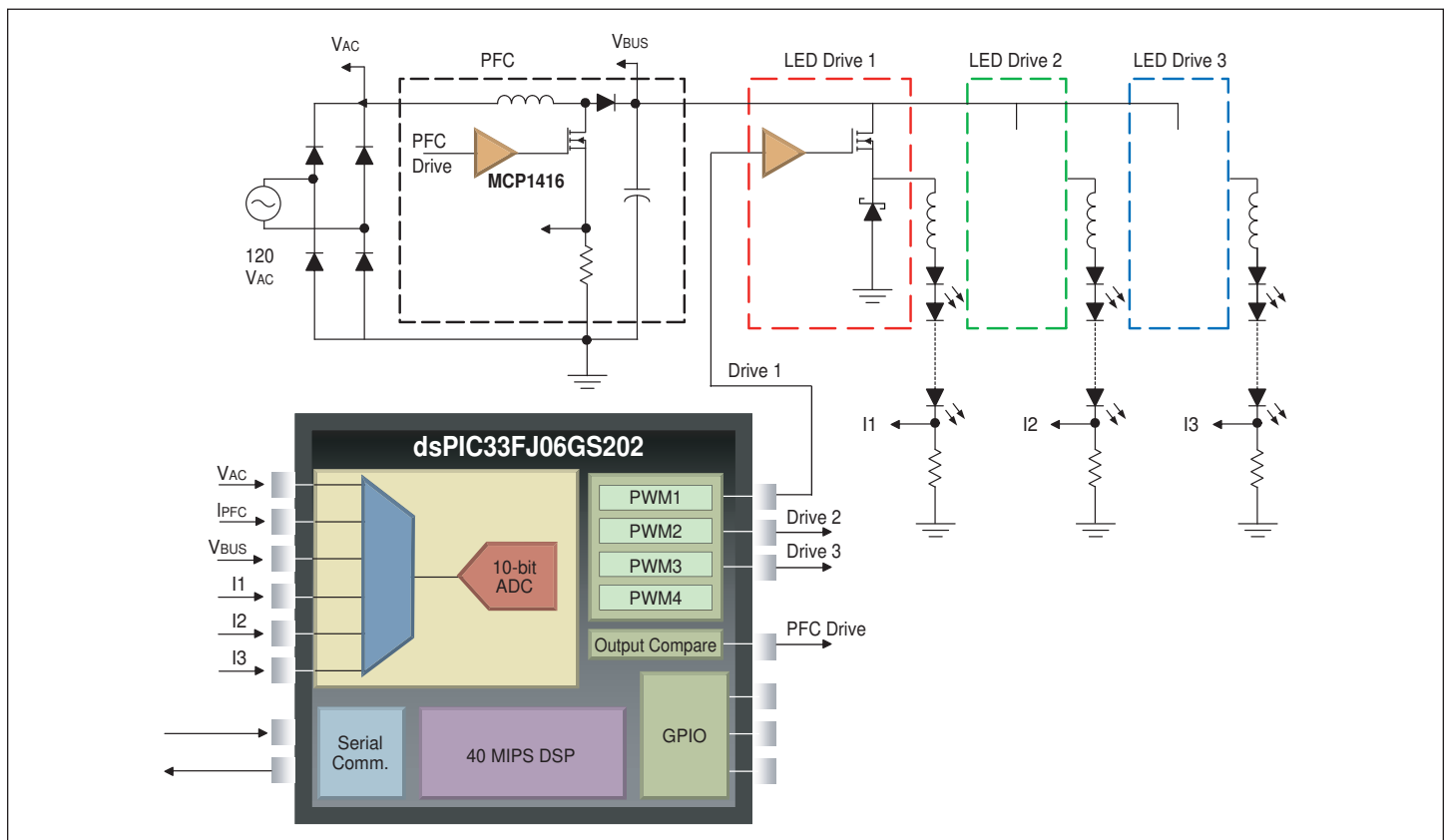

LED Lighting Solutions

Wired Communication Solutions for Lighting

Many lighting applications require some form of communication for remote control but also for diagnostic purposes. Some of the most common interfaces used in lighting are:

- 0-10V
- DMX512
- Digitally Addressable Lighting Interface (DALI)

0-10V Interface

All PIC microcontroller families offer models that integrate an Analog-to-Digital converter peripheral with a minimum of 8-bit resolution that allows them to connect to the industry standard 0-10V interface with minimum external component count. Most Flash PIC microcontroller models offer a 10-bit resolution ADC, while 12-bit resolution is available on selected models. Each I/O pin is protected by a pair of (clipping) diodes so to prevent latch-up and damages that could follow from the incorrect wiring of a 0-10V interface (over-voltage).

There are different 0-10V specifications based on the intended application. The 0-10V control interface for controllable ballasts is defined in Annex E of the IEC60929 specification. The 0-10V control interface for the entertainment industry is defined by ANSI E1.3-2001.

Digitally Addressable Lighting Interface (DALI)



DALI is a bi-directional digital protocol that requires a two wire connection system similar to the 0-10V interface, but offers individual lamp or group addressability in a bus configuration. The low speed Manchester encoding system used

allows for an inexpensive firmware implementation on most any PIC microcontroller. Many PIC devices offering an analog comparator peripheral can implement an advanced power saving techniques as demonstrated in application note AN809. Application note AN811 illustrates the implementation of a bridge between DALI and a standard RS-232 serial interface.

DALI Ballast Software Library

A DALI ballast software library is available for PIC MCUs that comply with the latest release of the IEC60929 specification. Contact your local sales office for availability.

Literature on the Web

- AN809 – Digitally Addressable DALI Dimming Ballast
- AN811 – The RS-232/DALI Bridge Interface

DMX512

The DMX512 interface (ANSI E1.11) has gained great popularity in theatrical/entertainment lighting applications because of its simplicity and low cost. It is based on a 250 Kbaud asynchronous serial interface that uses the standard RS-485 differential line transceivers. Transmitter and receivers can be implemented on most PIC microcontrollers in a few lines of code. PIC microcontrollers that offer a EUSART peripheral allow for the simplest and most efficient implementation of the protocol.

Application note AN1076 offers an example implementation of both a transmitter and typical DMX512 receiver on a PIC18F2420 model.

The figure below shows an application example where a PIC24FJ16GA002 implements a DMX512 receiver to control three PWM output channels (each capable of 16-bit resolution).

Literature on the Web

- AN1076 – Using a PIC Microcontroller for DMX512 Communication

PIC24FJ16GA002 Controlling 3 PWM Output Channels

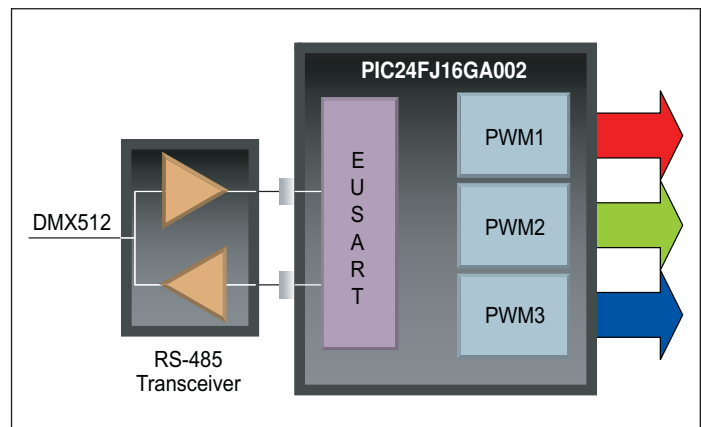

LED Lighting Solutions

Advanced Communication Solutions for Lighting

Several advanced wired and wireless communication interfaces are being evaluated for use in a multitude of innovative lighting applications including:

- ZigBee® and MiWi™ wireless protocols based on the IEEE 802.15.4 standard
- Wi-Fi™, IEEE 802.11
- Ethernet, IEEE 802.3
- USB
- CAN, LIN

ZigBee® Protocol



The ZigBee protocol is an industry standard protocol for wireless networking. Specifically designed for low cost and relatively low bandwidth automation applications it allows the quick deployment of several networking flexible topologies, including star, cluster and mesh.

PIC microcontrollers offer the ideal combination of performance and low power features required to implement an efficient ZigBee solution. Microchip offers a free ZigBee Residential stack implementation for the PIC18 and PIC24 family of microcontrollers. More information can be found in Application Note AN1232. Microchip also offers Zigbee PRO stack along with public application profiles such as Smart Energy Profile.

MiWi™ Protocol

The MiWi Wireless Networking Protocol is a simple protocol designed for low data rate, short distance, low-cost networks. Fundamentally based on IEEE 802.15.4™ for wireless personal area networks (WPANs) later expanded to support Microchip proprietary RF transceivers, the MiWi protocol provides an easy-to-use alternative for wireless communication. In particular, it targets smaller applications that have relatively small network sizes and with few hops between. For more details, check Application Note AN1066.

MiWi™ P2P Protocol

Microchip MiWi P2P is one of the wireless protocols that is supported in MiWi Development Environment (DE). It is a variation of IEEE 802.15.4, using Microchip's IEEE 802.15.4 compliant and other proprietary RF transceivers, which are controlled by Microchip 8, 16 or 32-bit microcontroller with a Serial Peripheral Interface (SPI). Application Note AN1204 describes the Microchip Wireless (MiWi) Peer-to-Peer (P2P) Protocol and its differences from IEEE 802.15.4.

Development Tools

MRF24J10 – a fully integrated 2.4 GHz IEEE 802.15.4 compatible transceiver

DM163027-4 – PICDEM Z 2.4 GHz Demonstration Kit

DM183023 – ZENA™ wireless network analyzer tool uses a simple graphical interface to configure the free Microchip ZigBee and MiWi protocol stacks.

Web Links

www.microchip.com/wireless

www.microchip.com/zigbee

www.microchip.com/miwi

Wi-Fi Interface

Microchip's Wi-Fi modules have been architected to ease integration at minimum system cost. Designing from a module removes effort and time from having to design with a chip. All module components are tuned for best performance and have been tested for a variety of antennas. Designers can simply design the module onto their board in order to go straight to production. Because the MRF24WB0MA and MRF24WB0MB modules are certified, designers can save tens of thousands of dollars for certification fees and about six months of engineering time. For high volume customers, the best path is to start with the module to get to market rapidly.

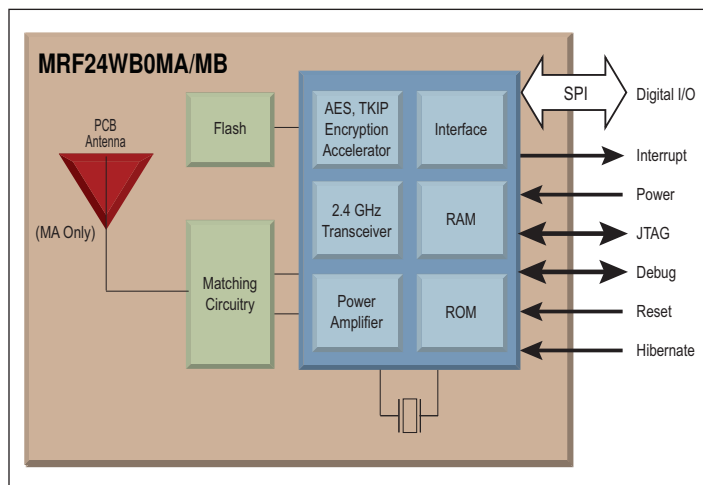

Wireless Tools

DM183032 – PICDEM PIC18 Explorer Board

DM240001 – Explorer 16 Demo Board

AC164134 – MRF24J40MA PICtail™ Plus Daughter Board

AC164137 – MRF49XA PICtail™ Plus Daughter Board

AC164138 – MRF89XA PICtail™ Plus Daughter Board

AC164136-4 – MRF24WB0MA Wi-Fi PICtail™ Plus Daughter Board

Web Link

www.microchip.com/wireless

LED Lighting Solutions

USB Interface

With the demise of the serial port, any application that requires a connection with a personal computer has now to be routed to the USB port. Some innovative lighting applications occasionally require such a connection to be established. Several models of PIC18F microcontrollers incorporate a complete USB interface. Several interface examples are offered to the designer to simplify the transition from serial port to USB and to integrate the application with existing Microsoft Windows® drivers.

Development Tools

DM163025 – PICDEM FS-USB Demonstration Board
DM320003-2 – PIC32 USB Starter Kit II

Web Link

www.microchip.com/usb

Ethernet Interface

Ethernet connectivity is becoming ubiquitous and most new office and industrial building are being wired for Ethernet. As lower cost solutions are becoming available it is increasingly tempting to use Ethernet for even the simplest control and diagnostic applications.

Ethernet Interface Controller

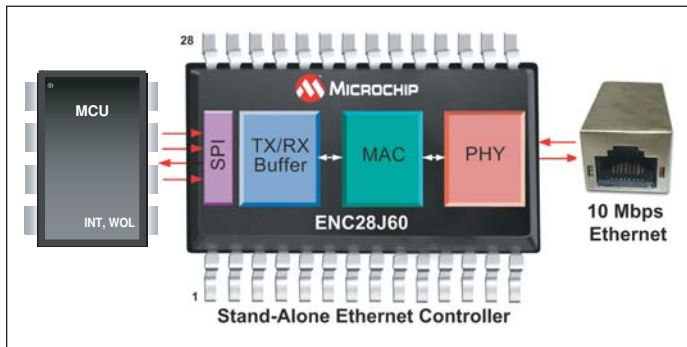

Microchip addresses the growing demand for a small and low-cost embedded Ethernet solution by offering the following:

- PIC32MX6XX and PIC32MX7XX families with integrated 10/100 Ethernet MAC, dedicated DMA interface supports packet scatter/gather for outstanding low CPU-overhead performance at full 100 Megabit/seconds. Industry standard RMI/MI interface, pre-programmed unique MAC address. This family is fully compatible with 10/100/1000 Base-T networks
- 10/100 Base-T ENC624J600 standalone Ethernet controllers which are IEEE 802.3 compliant, integrated with hardware cryptographic security engines and factory preprogrammed unique MAC address. This family is fully compatible with 10/100/1000 Base-T networks
- 10 Base-T ENC28J60 standalone Ethernet controller and the PIC18F97J60 family, which are IEEE 802.3 compliant and fully compatible with 10/100/1000 Base-T networks
- Free licensed and robust TCP/IP stack, which is optimized for the PIC18, PIC24 and PIC32 microcontroller and dsPIC digital signal controller families

- EUI-48™ and EUI-64™ enabled MAC address chips along with Serial EEPROM functionality
- A broad range of development tools to enhance the user's experience

Development Tools

DM320004 – PIC32 Ethernet Starter Kit
AC164123 – Ethernet PICtail™ Plus Daughter Board
AC164121 – Ethernet PICtail™ Daughter Board
DM240001 – Explorer 16 Development Board
DM163024 – PICDEM.net™ 2 Development Board

Web Link

www.microchip.com/ethernet

CAN and LIN Protocols

Both the CAN and LIN protocols were originally created for the automotive market. CAN was designed as a high reliability and speed protocol (up to 1 Mbit/s) for the harsh environment of the car electrical bus. LIN was later added as a simple low cost alternative for the control of non-critical modules on a vehicle. Both find occasional applications in lighting.

Many of the PIC18F, PIC24H, PIC32 microcontrollers and dsPIC DSCs include a complete CAN serial interface. The MCP25XX series of peripheral interfaces includes several CAN transceiver and CAN I/O expander devices.

All PIC microcontroller devices offering an EUSART module (PIC18F devices and most recent PIC16F devices) offer direct support for LIN bus connectivity with auto-baud rate detection and specific low power features.

Automotive Ambient Lighting Module Reference Design (APGRD004)



The Automotive Ambient Interior Lighting Module Reference Design demonstrates microcontroller-based control of RGB LED devices. This module can be controlled remotely by a master body controller via a LIN bus. These modules are offered in a very compact form-factor board and are comprised of a PIC12F615 MCU, an MCP2021 LIN transceiver/voltage regulator, and RGB LED. LIN commands are interpreted by the module to control color mixing (16,383 colors) and intensity (1023 levels). The kit ships with 4 modules to assign as lighting zones in a LIN or J2602 network. These modules can also be used in conjunction with the APGDT001 LIN Serial Analyzer to quickly create a working LIN network straight out of the box.

Development Tools

DM163005 – PICDEM LIN Demonstration Board
DM163011 – PICDEM CAN-LIN 2 Demonstration Board
APGDT001 – LIN Serial Analyzer Tool
APGRD004 – Ref Design, Automotive Ambient Lighting

Literature on the Web

- AN829 – LightKeeper Automotive Lighting Control Module, DS00829

Web Links

www.microchip.com/can
www.microchip.com/lin

Temperature Sensing Solutions for Power LED Applications

Every light source has a specific energy efficiency. A certain portion of the energy supplied to it is wasted in the form of heat. One of the fundamental differences between Power LED technology and other traditional sources of light is in the way this heat is transferred. In fact, LEDs are particularly good at producing a radiation with very narrow range of frequencies typically designed to produce a specific color in the visible spectrum. There is very little infrared (heat) radiation produced. All the heat produced by the light source has to be transferred instead by contact. Packaging technology plays an important role in facilitating the heat transfer from the LED, but an accurate thermal analysis of the entire lighting application (total thermal resistance from junction to ambient) is required to guarantee that the maximum temperature of the junction is not exceeded during operation. In particular, white LEDs employ phosphor materials to convert the monochromatic light emitted into a wider spectrum, to produce a “white” color. The phosphors are even more sensitive to temperature and can be easily damaged if overheated.

Before the LED junction reaches the maximum operating junction temperature (typically 125°C) the temperature increase will have negative impact on a number of LED characteristics including efficiency, light intensity, lifetime and color.

While the safe way to design a power LED application is to provide a low temperature resistance path to a heat sink that is dimensioned for the worst possible environmental and usage conditions, this might not always be possible for physical or cost constraints. For this reason driver ICs used in LED applications (such as the MCP1630 and MCP1650) often incorporate an over-temperature protection, performing what is substantially a device shutdown when the temperature rises above a given threshold. While this is effective to protect the device from reaching temperatures that could damage the LED (or the phosphor layer for white LED applications), the driver IC is not always guaranteed to be placed close to the emitting device(s). If the LEDs are arranged in modules, separate from the driving circuit, comprising several emitters connected in series or parallel, the temperature sensed by the driver could be considerably different from the actual module emitter’s junctions.

Logic Output Temperature Sensors

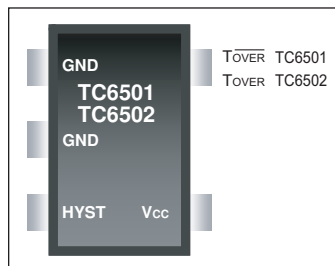

Low cost temperature sensing devices such as the TC6501 and TC6502 (offered in SOT-23 packages) can be conveniently placed near power LED(s) to obtain a more accurate temperature monitoring and provide a logic output fault signal.

The fault signal will be activated as soon as a factory-programmed temperature threshold is reached. Temperature threshold values can be selected in increments of 20°C as indicated in the following table.

TC6501/TC6502 Logic Output Temperature Sensors

Device	Temperature Threshold (°C)
TC6501P045VCT	45
TC6501P065VCT	65
TC6501P075VCT	75
TC6501P095VCT	95
TC6501P0105VCT	105
TC6501P0115VCT	115
TC6501P0120VCT	120
TC6501P0125VCT	125

Resistor-Programmable Temperature Switches

The MCP9509/10 devices are programmable logic output temperature switches. The temperature switch threshold can be programmed with a single external resistor, which provides high design flexibility and simplicity. In addition, this family of devices provide user programmable features such as 2°C and 10°C (typical) switch hysteresis and output structure configuration. The MCP9509 provides an open drain output, whereas the MCP9510 is offered in three different user selectable output configurations: Active-low/Active-high push pull and Active-Low Open-Drain output with an internal 100 kΩ pull-up resistor.

The MCP9509/10 operate from 2.7V to 5.5V. This family is capable of triggering for temperatures -40°C to +125°C with high accuracy.

MCP9509/10 Resistor-Programmable Temperature Switches

Device	Temperature Threshold (°C)
MCP9509CT-E/OT	-40°C to +125°C (Falling Hot to Cold)
MCP9509HT-E/OT	-40°C to +125°C (Rising Cold to Hot)
MCP9510CT-E/CH	-40°C to +125°C (Falling Hot to Cold)
MCP9510HT-E/CH	-40°C to +125°C (Rising Cold to Hot)

LED Lighting Solutions

Using TC6501 Open Drain Output for Current Set-Point Control

There are different ways that the TC6501 and TC6502 temperature sensors can be used in an application. The open-drain output of the TC6501 is useful for controlling signals in analog circuits. For example, the TC6501 could be used to limit a current reference set-point for a switch-mode power supply. It could also be connected to signals in op amp circuits to alter the behavior of the system when a temperature limit is exceeded (see figure below).

Using the TC6501 to Provide MCU Interrupt

If a microcontroller is present and managing the application, a TC6502 with CMOS active-high output signal can be used to provide an interrupt. The microcontroller in turn will be able to apply PWM dimming techniques to reduce the power output to the module (as shown in figure below).

Fan Controller Application Using TC6502

If a cooling device (fan) is available, a TC6502 device (with the HIST pin connected to Vcc to obtain a 10°C hysteresis threshold) can directly control a cooling fan to improve the heat transfer.

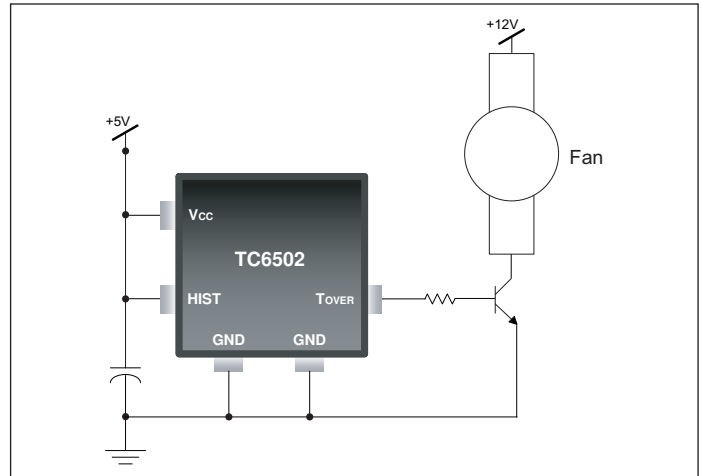

Using TC6501 Open Drain Output for Current Set-Point Control

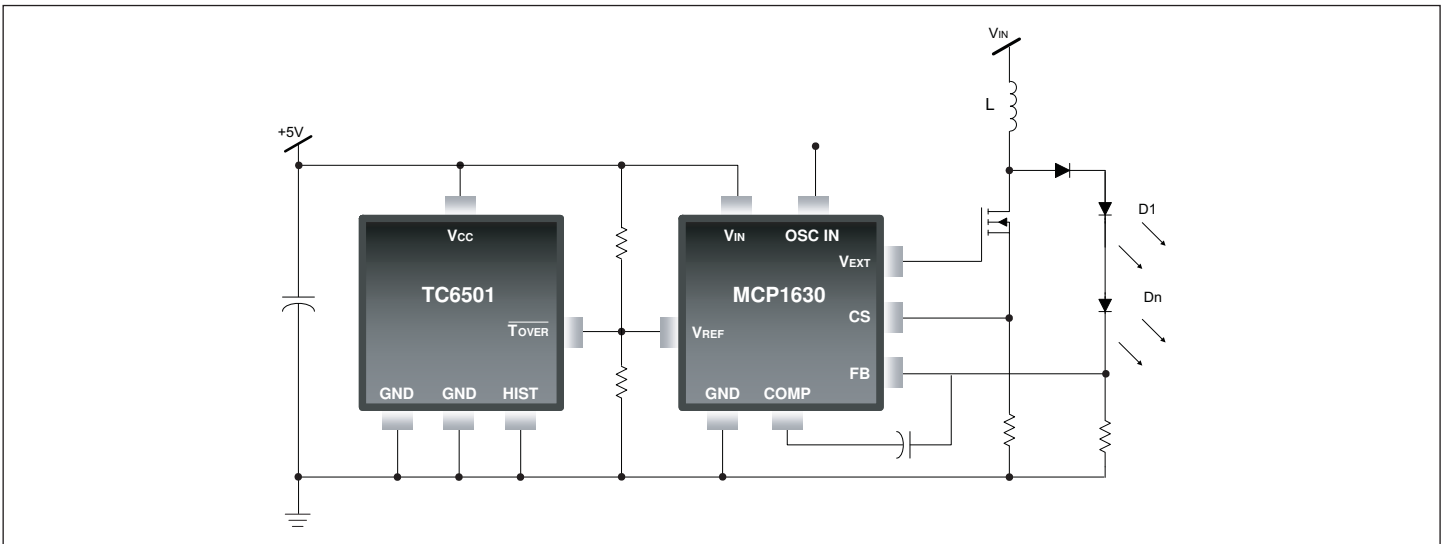

Using the TC6501 to Provide MCU Interrupt

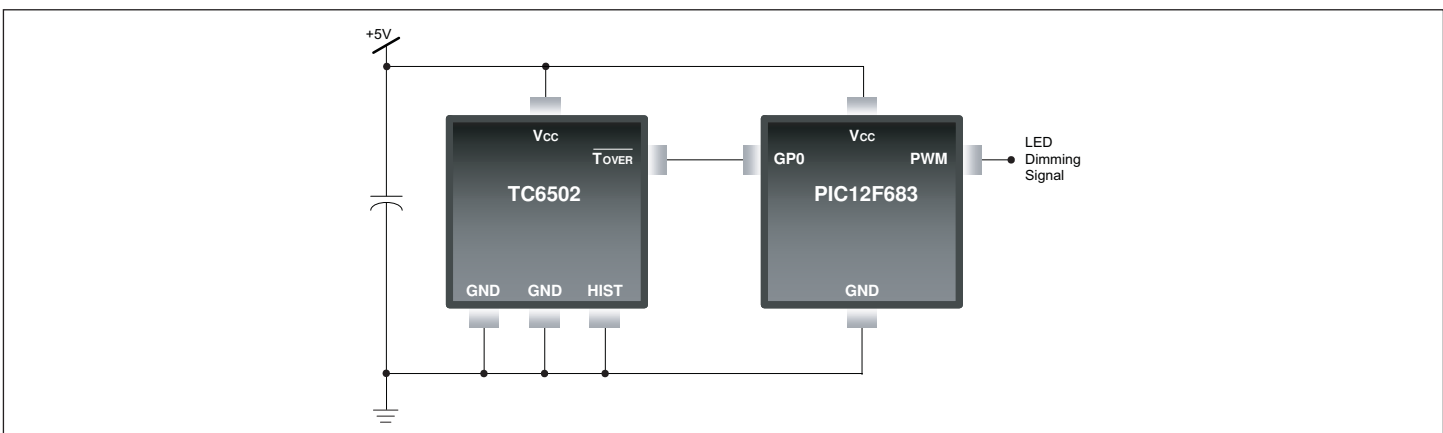

LED Lighting Solutions

Voltage Output Temperature Sensors

The most basic technique employed to protect the device from damaging over-temperature conditions is to provide a shutdown signal to the driver circuit when a pre-defined threshold is reached. However, this behavior can be unacceptable in applications where continuous lighting is required for safety or regulatory conditions. A more advanced approach can be obtained if a microcontroller is used to manage the lighting application providing closed loop control of the power supplied by the driver circuit. As the temperature approaches the threshold the current supplied can be reduced to limit the power output.

By using a Voltage Output Temperature Sensor such as the MCP9700 and MCP9701, placed on the LED module close to the emitting device, it is possible to provide a linear voltage feedback signal to a PIC microcontroller. This solution ensures that the light source can always operate at a power level that remains within temperature limits. Almost any kind of software algorithm can be implemented in the microcontroller to respond to the temperature feedback, allowing tremendous flexibility.

MCP9700/01 Voltage Output Temperature Sensors

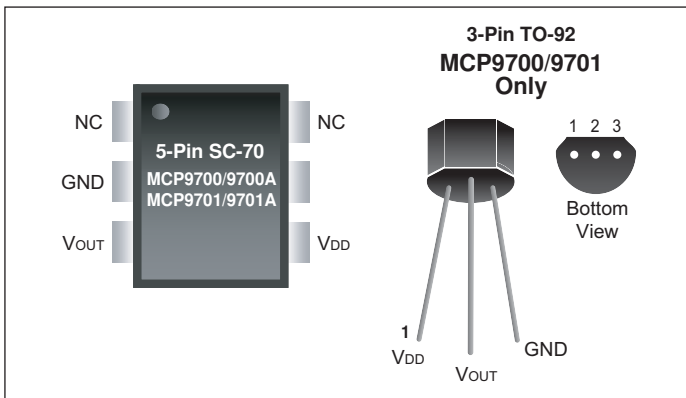

Power LED Thermal Control Circuit Using MCP9700 and MCP1650

Alternatively a PIC microcontroller can perform a direct PWM control (on/off) of the entire LED driving circuit at low frequency (100-120 Hz). By limiting the average on-time of the power LED, the total power output can be limited. This technique has the advantage of stabilizing the application temperature while maintaining the LED driving current constant therefore limiting the LED color shift produced by forward current changes. The diagram below illustrates an example of a switching DC-DC converter design based on the MCP1650 boost regulator controlled by a 6-pin PIC10F220 microcontroller.

Learn More

The Intelligent Power Supply Design Center (www.microchip.com/power) features temperature sensing solutions, including application notes and product selection charts.

Literature on the Web

- DG4 – Temperature Sensor Design Guide, DS21895

Power LED Thermal Control Circuit Using MCP9700 and MCP1650

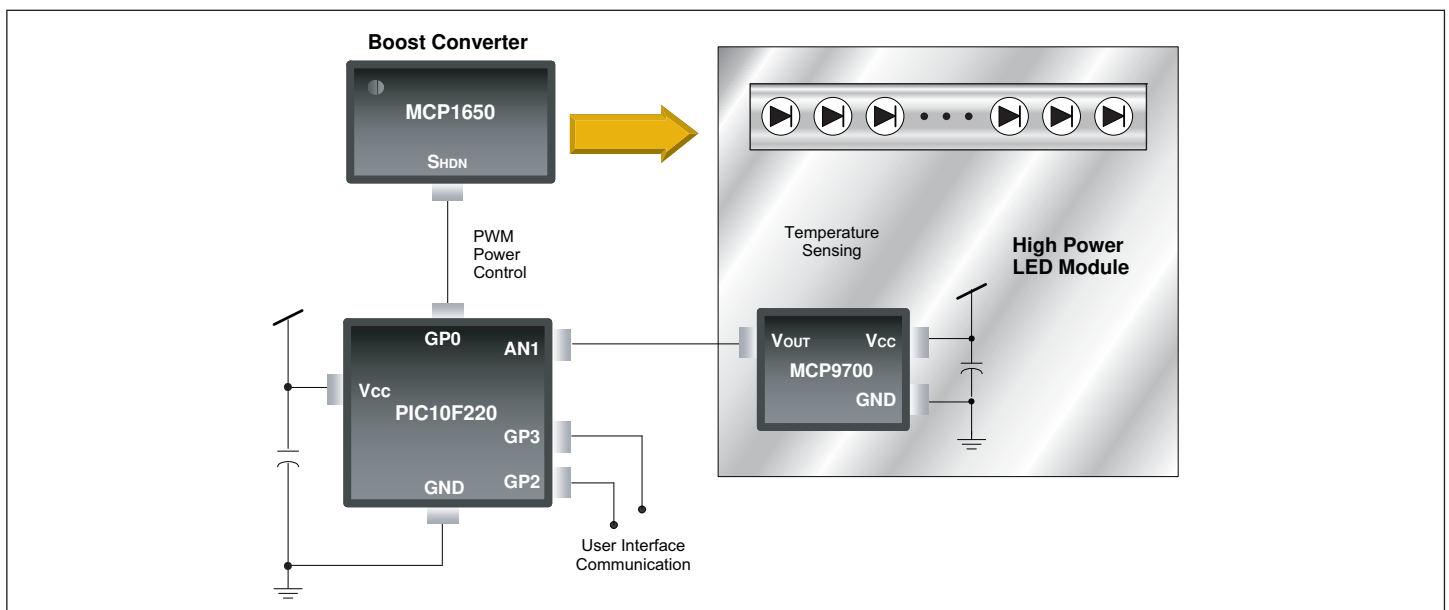

Support

Microchip is committed to supporting its customers in developing products faster and more efficiently. We maintain a worldwide network of field applications engineers and technical support ready to provide product and system assistance. In addition, the following service areas are available at www.microchip.com:

- **Support** link provides a way to get questions answered fast: <http://support.microchip.com>
- **Sample** link offers evaluation samples of any Microchip device: <http://sample.microchip.com>
- **Forum** link provides access to knowledge base and peer help: <http://forum.microchip.com>
- **Buy** link provides locations of Microchip Sales Channel Partners: www.microchip.com/sales

Sales Office Listing

AMERICAS

Atlanta

Tel: 678-957-9614

Boston

Tel: 774-760-0087

Chicago

Tel: 630-285-0071

Cleveland

Tel: 216-447-0464

Dallas

Tel: 972-818-7423

Detroit

Tel: 248-538-2250

Kokomo

Tel: 765-864-8360

Los Angeles

Tel: 949-462-9523

Santa Clara

Tel: 408-961-6444

Toronto

Mississauga, Ontario

Tel: 905-673-0699

EUROPE

Austria - Wels

Tel: 43-7242-2244-39

Denmark - Copenhagen

Tel: 45-4450-2828

France - Paris

Tel: 33-1-69-53-63-20

Germany - Munich

Tel: 49-89-627-144-0

Italy - Milan

Tel: 39-0331-742611

Netherlands - Druen

Tel: 31-416-690399

Spain - Madrid

Tel: 34-91-708-08-90

UK - Wokingham

Tel: 44-118-921-5869

Training

If additional training interests you, then Microchip can help. We continue to expand our technical training options, offering a growing list of courses and in-depth curriculum locally, as well as significant online resources – whenever you want to use them.

- Regional Training Centers: www.microchip.com/rtc
- MASTERS Conferences: www.microchip.com/masters
- Worldwide Seminars: www.microchip.com/seminars
- eLearning: www.microchip.com/webseminars
- Resources from our Distribution and Third Party Partners www.microchip.com/training

ASIA/PACIFIC

Australia - Sydney

Tel: 61-2-9868-6733

China - Beijing

Tel: 86-10-8528-2100

China - Chengdu

Tel: 86-28-8665-5511

China - Hong Kong SAR

Tel: 852-2401-1200

China - Nanjing

Tel: 86-25-8473-2460

China - Qingdao

Tel: 86-532-8502-7355

China - Shanghai

Tel: 86-21-5407-5533

China - Shenyang

Tel: 86-24-2334-2829

China - Shenzhen

Tel: 86-755-8203-2660

China - Wuhan

Tel: 86-27-5980-5300

China - Xiamen

Tel: 86-592-2388138

China - Xian

Tel: 86-29-8833-7252

China - Zhuhai

Tel: 86-756-3210040

ASIA/PACIFIC

India - Bangalore

Tel: 91-80-3090-4444

India - New Delhi

Tel: 91-11-4160-8631

India - Pune

Tel: 91-20-2566-1512

Japan - Yokohama

Tel: 81-45-471- 6166

Korea - Daegu

Tel: 82-53-744-4301

Korea - Seoul

Tel: 82-2-554-7200

Malaysia - Kuala Lumpur

Tel: 60-3-6201-9857

Malaysia - Penang

Tel: 60-4-227-8870

Philippines - Manila

Tel: 63-2-634-9065

Singapore

Tel: 65-6334-8870

Taiwan - Hsin Chu

Tel: 886-3-572-9526

Taiwan - Kaohsiung

Tel: 886-7-536-4818

Taiwan - Taipei

Tel: 886-2-2500-6610

Thailand - Bangkok

Tel: 66-2-694-1351

1/26/09

Microcontrollers • Digital Signal Controllers • Analog • Memory • Wireless

The Microchip name and logo, the Microchip logo, dsPIC, MPLAB and PIC are registered trademarks of Microchip Technology Incorporated in the U.S.A. and other countries. MiWi, PICDEM, PICDEM.net, PICtail and ZENA are trademarks of Microchip Technology Incorporated in the U.S.A. and other countries. All other trademarks mentioned herein are property of their respective companies. © 2010, Microchip Technology Incorporated, All Rights Reserved. Printed in the U.S.A. 7/10

DS01036F



MICROCHIP
www.microchip.com

Microchip Technology Inc.
2355 W. Chandler Blvd.
Chandler, AZ 85224-6199