



Chipsmall Limited consists of a professional team with an average of over 10 year of expertise in the distribution of electronic components. Based in Hongkong, we have already established firm and mutual-benefit business relationships with customers from,Europe,America and south Asia,supplying obsolete and hard-to-find components to meet their specific needs.

With the principle of "Quality Parts,Customers Priority,Honest Operation,and Considerate Service",our business mainly focus on the distribution of electronic components. Line cards we deal with include Microchip,ALPS,ROHM,Xilinx,Pulse,ON,Everlight and Freescale. Main products comprise IC,Modules,Potentiometer,IC Socket,Relay,Connector.Our parts cover such applications as commercial,industrial, and automotives areas.

We are looking forward to setting up business relationship with you and hope to provide you with the best service and solution. Let us make a better world for our industry!



## Contact us

Tel: +86-755-8981 8866 Fax: +86-755-8427 6832

Email & Skype: info@chipsmall.com Web: www.chipsmall.com

Address: A1208, Overseas Decoration Building, #122 Zhenhua RD., Futian, Shenzhen, China



NOTES:

1. MATERIALS AND FINISHES:

BODY, LOCKWASHER & HEX NUT - BRASS (ASTM-B16 H02, C36000), NICKEL PLATING  
 CONTACT PIN - BeCu, GOLD PLATING  
 INSULATOR - PTFE PER ASTM D 1710 OR EQUIV.  
 GASKET - SILICONE RUBBER, COLOR RED

2. ELECTRICAL:

A. IMPEDANCE: 50 OHM  
 B. FREQUENCY RANGE: DC - 11 GHz

3. MECHANICAL:

A. TEMPERATURE RANGE: -65° C TO +165° C

4. PACKAGING:

A. QUANTITY: SINGLE PACK  
 B. MARKING: BAG TO BE MARKED  
 \*AMPHENOL, APH-SMAJ-NJBHD, AND DATE CODE

APH-SMAJ-NJBHD		REVISIONS			
DRAWING NO.	REV	DESCRIPTION	DATE	ECO	APPR
THIRD ANGLE PROJ.	A	RELEASE TO MFG.	9/12/06	46263	CPM/

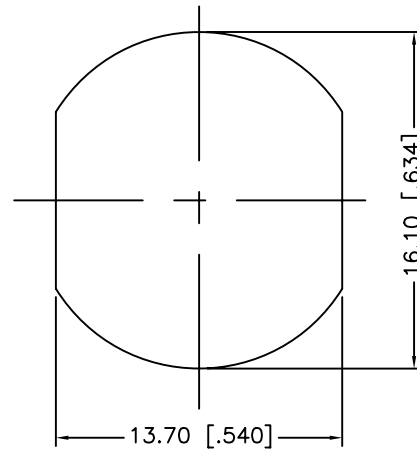

RECOMMENDED MOUNTING HOLE

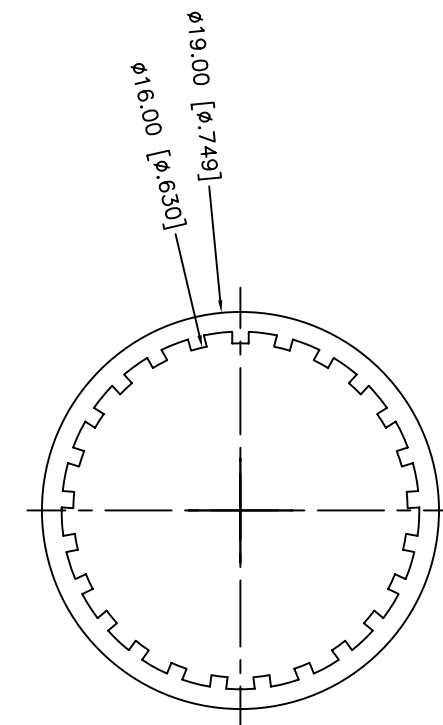
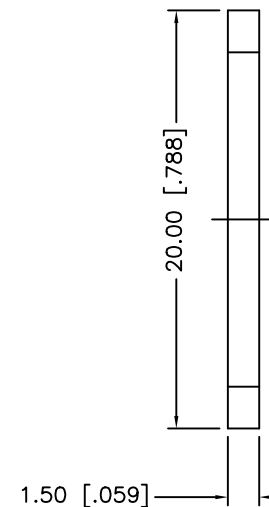
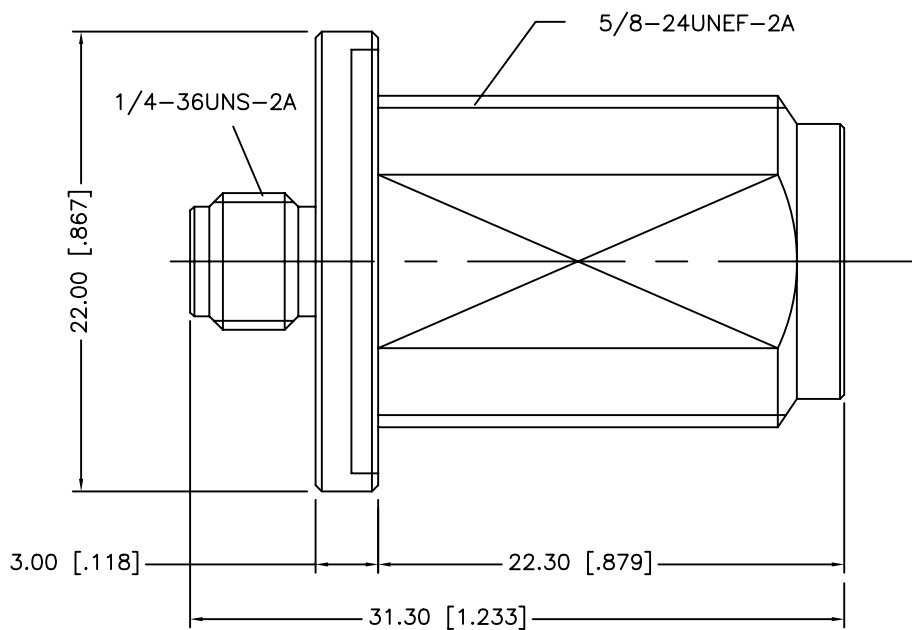

19 HEX

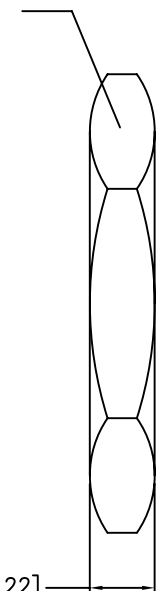

UNLESS OTHERWISE SPECIFIED, DIMENSIONS ARE IN INCHES AND TOLERANCES ARE:  
 2 PLACE DECIMAL ±0.015 (0,381 mm)  
 3 PLACE DECIMAL ±0.005 (0,127 mm)  
 ANGLES ± 1°

NOTICE - These drawings, specifications, or other data (1) are, and remain the property of Amphenol Corp. (2) must be returned upon request; and (3) are confidential and not to be disclosed to any person other than those to whom they are given by Amphenol Corp. The furnishing of these drawings, specifications, or other data by Amphenol Corp., or to any other person to anyone for any purpose is not to be regarded by implication or otherwise in any manner licensing, granting rights or permitting such holder or any other person to manufacture, use or sell any product, process or design, patented or otherwise, that may in any way be related to or disclosed by said drawings, specifications, or other data.

MATERIAL	DRAWN	C. McGRATH	DATE	4/29/05
	ENGINEER	D. BARTHELMES	DATE	4/29/05
REFERENCE	APPROVED	D. BARTHELMES	DATE	9/8/06
	CAD FILE	H:\DEPT611\ASSY\APH\SMAJ-NJBHD		

TITLE	N FEMALE TO SMA FEMALE BULKHEAD ADAPTER	
CODE ID	DWG SIZE	DRAWING NO.
74868	B	APH-SMAJ-NJBHD

Amphenol Amphenol Corporation RF/Microwave Operations Danbury, Conn. U.S.A. 06810		
SCALE: 2:1	SHEET	OF
ISSUE	A	