



Chipsmall Limited consists of a professional team with an average of over 10 year of expertise in the distribution of electronic components. Based in Hongkong, we have already established firm and mutual-benefit business relationships with customers from,Europe,America and south Asia,supplying obsolete and hard-to-find components to meet their specific needs.

With the principle of “Quality Parts,Customers Priority,Honest Operation,and Considerate Service”,our business mainly focus on the distribution of electronic components. Line cards we deal with include Microchip,ALPS,ROHM,Xilinx,Pulse,ON,Everlight and Freescale. Main products comprise IC,Modules,Potentiometer,IC Socket,Relay,Connector.Our parts cover such applications as commercial,industrial, and automotives areas.

We are looking forward to setting up business relationship with you and hope to provide you with the best service and solution. Let us make a better world for our industry!



Contact us

Tel: +86-755-8981 8866 Fax: +86-755-8427 6832

Email & Skype: info@chipsmall.com Web: www.chipsmall.com

Address: A1208, Overseas Decoration Building, #122 Zhenhua RD., Futian, Shenzhen, China



AP-K2N CRIMPING MACHINE

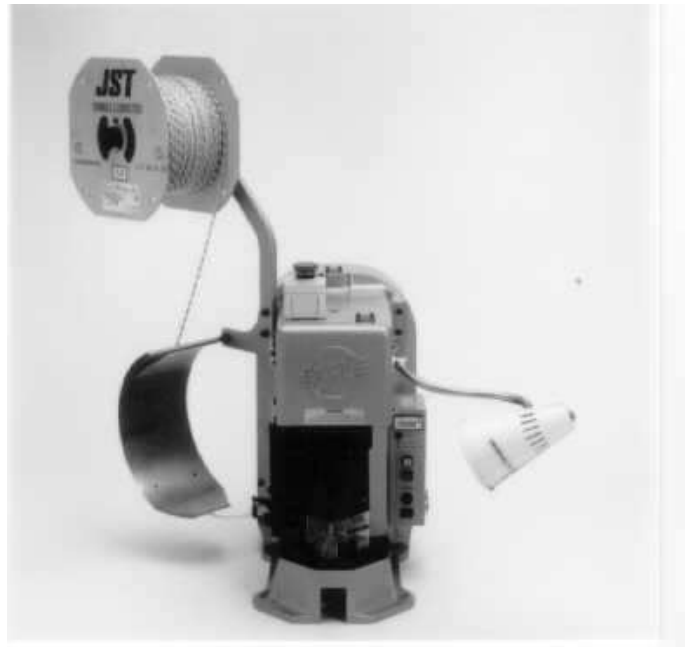

OPERATION

MANUAL

JST
The Quality Connection

PREFACE

The AP-K2N semi-automatic crimping machine is easy to operate, and is suitable for mass production of crimped harnesses with chain terminals.

Before using the AP-K2N please read this manual to ensure that you are familiar with the features of the machine and the layout of the operating controls. We recommend that you always keep this manual near the machine to use for reference when required. This manual also contains information on maintenance, fault-finding and adjustment of the crimping machine and its associated tooling.

For safe operation

- THIS MACHINE IS A POWER PRESS AND SHOULD NEVER BE USED WITHOUT THE SAFETY GUARDS FITTED.
- If you think that something is wrong with the machine, immediately turn OFF the machine and disconnect the lead from the power supply. Guards must only be removed by an authorised person during setting, adjustment and maintenance.
- The maximum measured sound output generated by the Crimping Press is 86 dB. It is recommended that ear defenders are worn whilst operating the machine.
- Do not modify or adapt the machine without prior consent of JST.
- This crimping machine complies with the CE directive for machinery and has the **CE** mark affixed to indicate its compliance.
- This crimping machine must not be incorporated into other machinery without the consent of JST (ref. The Supply of Machinery (safety) Regulations 1992, S.I 1992/3073).

Table of Contents

1. SPECIFICATIONS.....	4
1 - 1 Crimping Machine Specifications.....	4
1 - 2 Applicator Specifications.....	4
2. INSTALLING AND TRANSPORTING THE MACHINE.....	5
2 - 1 Installation.....	5
2 - 2 Transporting.....	5
3. PREPARATION FOR OPERATION.....	6
3 - 1 Mounting the Reel Hanger.....	6
3 - 2 Mounting the Applicator.....	6
3 - 3 Mounting the Terminal Reel.....	7
3 - 4 Mounting the Safety Guard.....	8
4. CONTROL BOX CONFIGURATION.....	12
5. OPERATION.....	13
5 - 1 Manual Operation.....	13
5 - 2 Operation under Power.....	14
6. APPLICATOR.....	15
6 - 1 Terminal Feed Position Adjustment.....	15
6 - 2 Bell Mouth Adjustment.....	16
6 - 3 Feed-finger Travel Adjustment.....	17
6 - 4 Crimp Adjustment.....	17
6 - 5 Die Part Replacement.....	18
6 - 6 Lubrication of Applicator.....	18
7. CRIMPING MACHINE MAINTENANCE.....	19
7 - 1 Lubrication.....	19
7 - 2 Inspection and Repair.....	21
8. FAULT FINDING.....	22
9. EXPLODED VIEWS AND PARTS LISTS.....	26
AP-K2N Crimping Machine Exploded Diagram.....	26
MK-L Applicator.....	28
MKS-L Applicator.....	30
MKF-L Applicator.....	32
MKS-LS Applicator.....	34

1. SPECIFICATIONS

The crimping machine is composed of the crimping press and an applicator. There are two basic types of applicators (a total of four models).

Models MK-L and MKF-L for end feeding terminals, and models MKS-L and MKS-LS for side feeding terminals. The crimping machine utilizes a quick change system thus allowing quick change-over times.

1.1 Crimping Machine Specifications

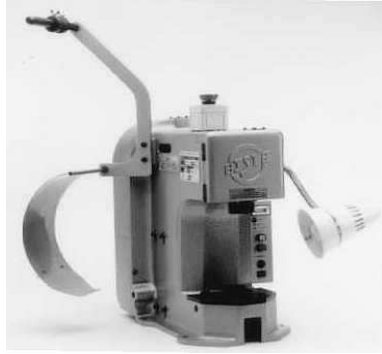

- Model no: AP-K2N
- ⊗ External dimensions: 280mm Wide x 480mm Long x 560mm High
 - ⊗ Weight: 90 Kg
 - ⊗ Power supply: 220/240V AC single phase 50/60 Hz
 - ⊗ Power consumption: 680VA
 - ⊗ Crimping force: 1500 Kg
 - ⊗ Ram stroke: 30mm
 - ⊗ Ram speed: 260 strokes per minute (60 Hz), and 220 strokes per minute (50 Hz)
 - ⊗ Closed height: 160.0 mm ± 0.01 at B.D.C

1.2 Applicator specifications

Model no. MK-L (for-end feeding terminals)

- ⊗ Weight 6.8 Kg
- ⊗ Feed pitch 30mm max.
- ⊗ Crimp height adjustment: Dial type

Model no. MKS-L (for side-feeding terminals)

- ⊗ Weight 6.4 Kg
- ⊗ Feed pitch 30mm max.
- ⊗ Crimp height adjustment: Dial type

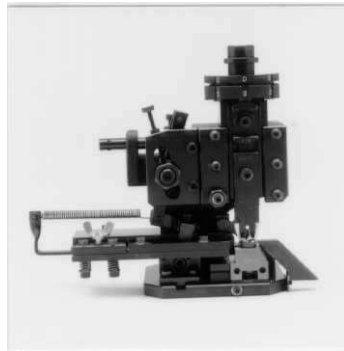

Model no. MKF-L (for-end feeding flag terminals)

- ⊗ Weight 6.8 Kg
- ⊗ Feed pitch 30mm max.
- ⊗ Crimp height adjustment: Dial type

Model no. MKS-LS (for side feeding terminals)

- ⊗ Weight 4.5 Kg
- ⊗ Feed pitch 30mm max.
- ⊗ Crimp height adjustment: Dial type

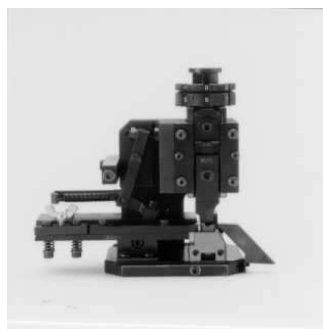

2 INSTALLING AND TRANSPORTING THE MACHINE

2.1 Installation

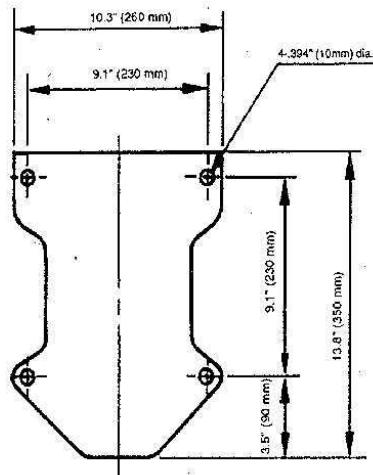

Mount the crimping machine on a solid foundation, place a rubber mat between the machine and foundation to reduce vibration and stabilize the machine.

The diagram to the left illustrates the footprint dimensions of the machine. Secure the machine to the foundation with four M8 bolts.

The machine should be mounted so that the crimping dies are at the approximate eye level of a seated operator.

CAUTION

Ensure that the belt cover of the crimping machine does not overhang the edge of the mounting surface.

2.2 Transporting

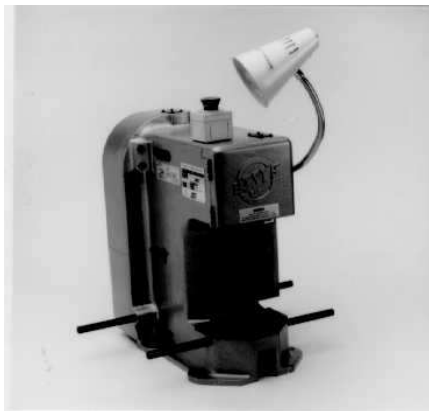

Always mount the handles supplied with the toolbox to move the machine (as shown in the photograph on the left).

The machine should always be transported by placing the lifting handles onto the arms of a fork-lift truck.

DO NOT ATTEMPT TO LIFT MANUALLY.

3. PREPARING FOR OPERATION

3.1 Mounting the Reel Hanger

Due to packing considerations, when you receive the machine the reel hanger is not mounted on the machine. Assemble the reel hanger then mount it on the machine as illustrated below.



3.2 Mounting the applicator (All types)

Step 1

Loosen bolts A & B with a 5mm hexagon wrench supplied with the tool-kit.

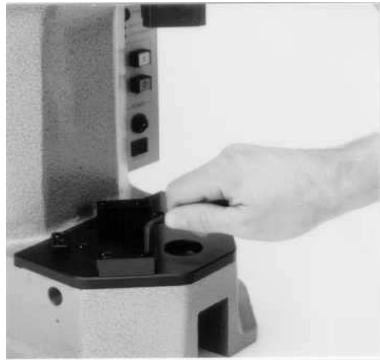

Step 2

Remove the protective rubber collar from under the dials on the applicator ram.



Step 3

Place the applicator on the base-plate of the crimping machine. Pull up the applicator ram whilst simultaneously pushing the feed lever in the direction of the arrow shown in the photograph below, so that the collar on the shank slides into the groove on the press ram. Then push the applicator fully back into the press.



CAUTION

ENSURE THAT THE SHANK IS CORRECTLY LOCATED IN THE RAM. THERE IS A DANGER OF MAJOR TOOLING DAMAGE IF THE TOOLING IS NOT LOCATED CORRECTLY (AS IN THE PHOTOGRAPH BELOW).

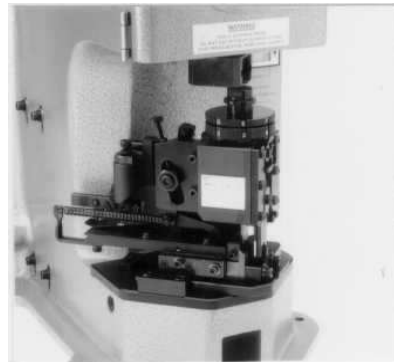

Step 4

Securely fasten the clamps with the 5 mm hexagon key, and visually check that the tooling is mounted correctly.



3.3 Mounting the Terminal Reel

Mount the terminal reel to the reel hanger so that the terminal barrels are facing the reel guide, then feed the terminals through the terminal guide to the applicator.



Mounting the MKS-L or MKS-LS Applicator

Step 1

Rotate the wing bolt clockwise to raise the pressure plate. Feed the terminal strip between the guide rails.

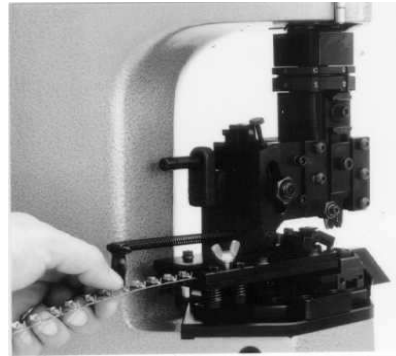

Mounting the MK-L Applicator

Step 1

Push down the tension lever and engage the hook with the feed plate so that the pressure pad rises. Feed the terminal strip between the guide rails.

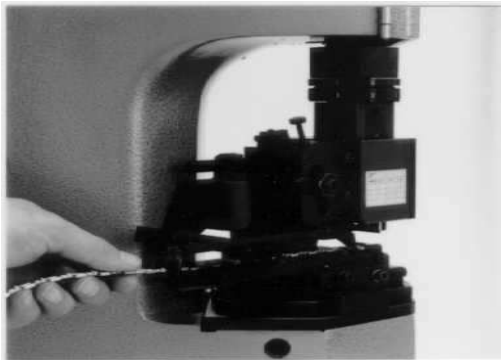

Step 2

Place the first terminal in position so that the terminal is centralised over the anvil. Rotate the wing bolt counter-clockwise to lower the pressure plate so that pressure is applied to the terminal.

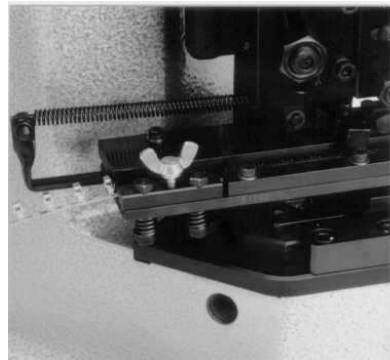

Step 2

Place the first terminal at the correct crimping position. Release the hook from the feed plate to allow the pressure pad to apply pressure on the strip.

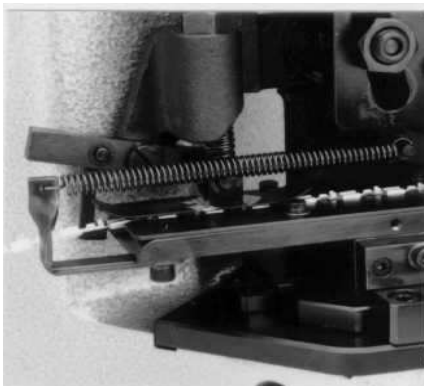
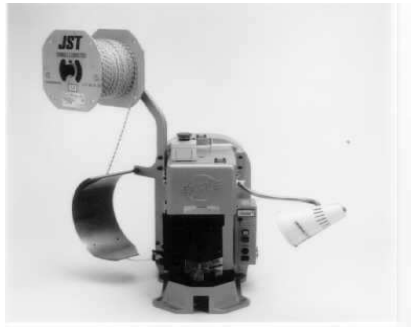
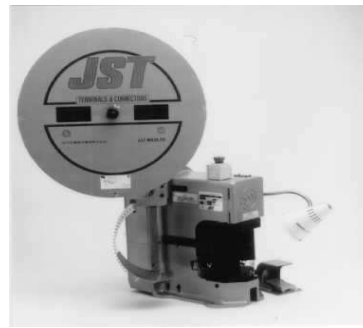

Illustration of Terminal reels mounted on the AP-K2N Crimping Machine



MK-L



MKS-L

3.4 Mounting the safety guard

For reasons of safety and to comply with legislation, safety guards must always be mounted to the crimping machine. The above photographs illustrate the AP-K2N crimping machine with the safety guards fitted.

The following photographs illustrate the different types of guards available for the range of JST applicators.

WARNING

**AN AUTHORISED COMPETENT PERSON
MUST ONLY CARRY OUT THE
FOLLOWING OPERATIONS.**

When using the MK-L Applicator.

Step 1

Secure the fabricated steel guard (JST UK-7), onto the Applicator using the cap head socket screws supplied.



Step 2

Secure the die guard (JST UK-1), onto the applicator using the cap head socket screws supplied.



Step 3

Select the appropriate side guard (JST UK-4), and mount onto the side guard support bracket (JST UK-9), using the countersunk screws supplied.

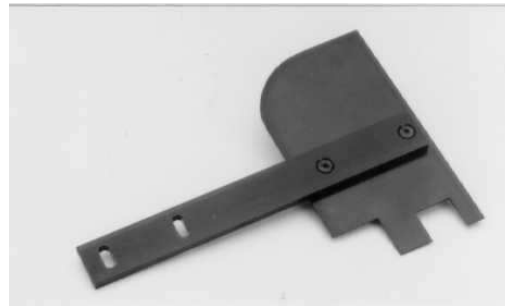

Step 4

Remove the two upper motor fixing screws and clamp the side guard support bracket onto the press utilising these screws.

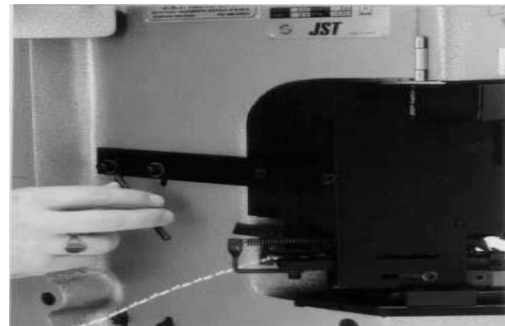

Step 5

Adjust the side guard support to achieve the best relationship between guard and applicator.

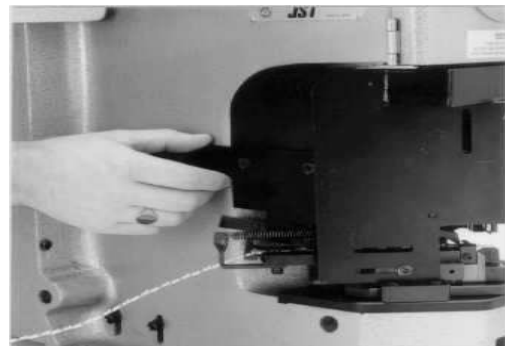

Step 6
Tighten the screws and check that the guards are correctly and securely fitted.



Step 4
Remove the two upper motor fixing screws and clamp the side guard support bracket onto the press utilizing these screws.

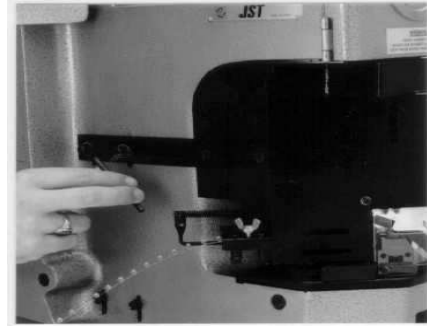

When using the MKS-L Applicator

Step 1
Secure the fabricated steel guard (JST UK-7), to the applicator using the cap head socket screws supplied.



Step 5
Adjust the side guard support to achieve the best relationship between guard and applicator.

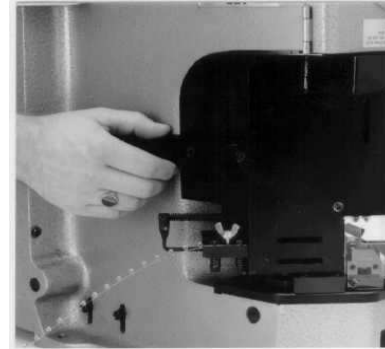

Step 2
Secure the die guard (JST UK-6), onto the applicator using the cap head socket screws supplied.



Step 6
Tighten the screws and check that the guards are correctly and securely fitted.

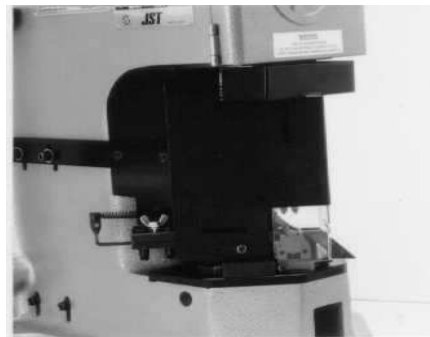

Step 3
Select the appropriate side guard (JST UK-3), and mount onto the side guard support bracket (JST UK-9), using the countersunk screws provided.

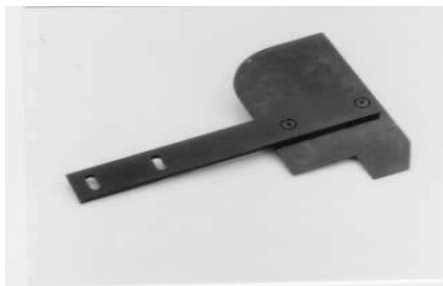

When using the MKS-L Applicator for SPC or PSL splices

Step 1

Secure the fabricated steel guard (JST UK-17), to the applicator using the cap head screws supplied.



Step 4

Remove the two upper motor fixing screws and clamp the side guard support bracket onto the press utilizing these screws.

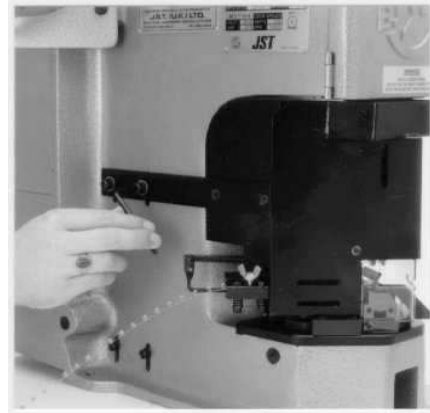

Step 2

Secure the fabricated steel guard (JST UK-135), onto the side face of the applicator using the cap head screws supplied.



Step 5

Adjust the side guard support bracket to achieve the best relationship between guard and applicator.



Step 3

Select the appropriate side guard (JST UK-3), and mount onto the side guard support bracket (JST UK-9), using the countersunk screws supplied..



Step 6

Tighten the screws and check that the guards are correctly and securely fitted.



When using the MKF-L Applicator

Step 1

Secure the fabricated steel guard (JST UK-35), to the applicator using the cap head screw supplied.



Step 2

Select the appropriate side guard (JST UK-95), and mount onto the side guard support bracket (JST UK-9), using the countersunk screws supplied.

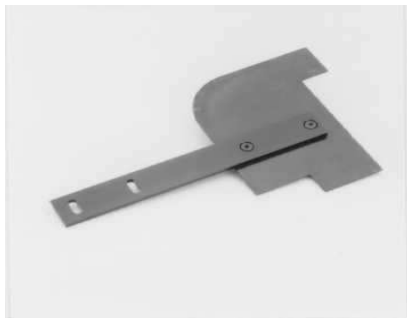

Step 3

Remove the two upper motor fixing screws and clamp the side guard support bracket onto the press utilizing these screws.

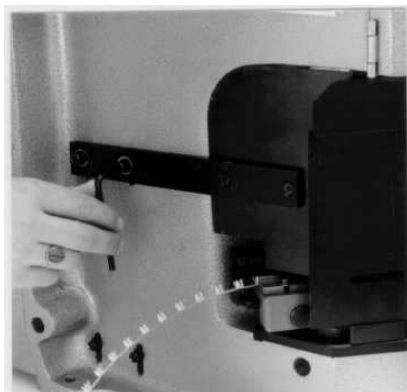

Step 4

Adjust the side guard support bracket to achieve the best relationship between guard and applicator.



Step 5

Tighten the screws and check that the guards are correctly and securely fitted.

IMPORTANT

If the safety guards become damaged or worn they must be replaced immediately. Please contact the JST Technical Department for replacement guards.

4. CONTROL BOX CONFIGURATION

1. Counter

Counts the number of crimped terminations. Reset the counter to 0 to begin counting operations.

2. Reset Push-button

Press this button to reset the counter (resets the counter to 0)

3. Function Indicator Lamps

- Rear Cover
The rear cover indicator lamp is lit when the belt-cover is open. Whilst this lamp is lit, the motor does not operate even if the Power On push-button is pushed.

CAUTION

DO NOT OPEN THE BELT COVER WHILST MOTOR IS RUNNING, BECAUSE THE FLYWHEEL CONTINUES TO ROTATE FOR A FEW SECONDS AFTER THE MOTOR IS TURNED OFF DUE TO INERTIA STORED IN THE FLYWHEEL.

- Auto Power-Off
When the crimping operation stops for a period of approximately 3 minutes or more, for example when you unintentionally leave the motor running after finishing work or temporarily stop the operation, the motor automatically stops and the Auto Power-off indicator lamp illuminates.

If the Rear Cover indicator illuminates, close the cover and press the Power On push-button to restart. If the Auto Power Off indicator illuminates, just press the Power On push-button to restart.

4. Power On Push-button (green Indicator Lamp)

Press this button to turn on the motor. The green indicator lamp illuminates and stays lit whilst the motor is running.

5. Power Off Push-button (Red Indicator Lamp)

Press this button to turn off the motor. The red Power Off indicator lamp illuminates.

6. Circuit Protector Push-button (Thermal Overload device)

When the crimping machine is overloaded, the Circuit Protector push-button 'pops out', and the motor stops. Wait for at least one minute, press the Circuit Protector Push-button in, then press the Power On push-button. Contact the JST Service Department if you think that the Circuit Protector is activated too often because the press may require attention.

7. Operation Light Switch (Ope. Light)

This switch controls the Worklamp. Press it to the right to turn the light on, and to the left to turn it off. The lamp-bulb is rated at 40 Watts and is of the 'Rough Service' type. Do not exceed 40 Watts because the surface temperature of the worklamp exceeds the maximum recommended temperature.

1. COUNTER
2. RESET
3. FUNCTION INDICATOR LAMPS
4. POWER ON PUSH-BUTTON (GREEN)
5. POWER OFF PUSH-BUTTON (RED)
6. CIRCUIT PROTECTOR PUSH-BUTTON
7. OPERATION LAMP SWITCH



5. OPERATION

WARNING

Disconnect the press from the power supply before operating by hand. Operations by hand whilst guards are removed must only be performed by authorized competent persons.

5.1 Manual Operation

CAUTION

When using an applicator for the first time after fitting it in the press, or whenever a die-part is replaced or the applicator is adjusted, ensure that the press is manually cycled at least one revolution. This is a very important operation to ensure that the terminals are crimped correctly and it also allows a degree of 'feel' through the crank handle which prevents major tooling damage from occurring if the die-parts have been installed incorrectly.

Step 1

Remove the cap head socket screws from the ram cover using the hexagon key supplied with the tool-kit, and open the belt cover.

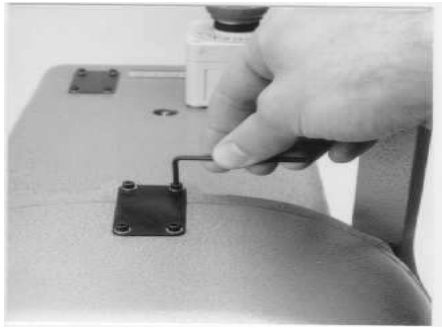

Step 2

Manually operate the solenoid by pushing the clutch lever in a downward direction until the clutch 'clicks'.

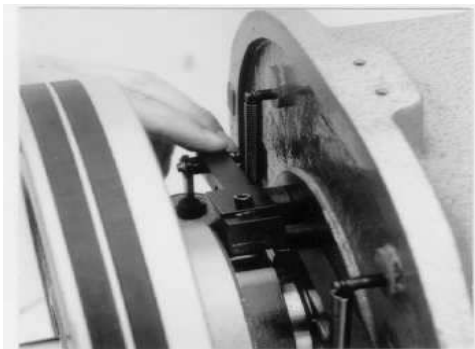

Step 3

Place the hand-crank supplied in the press tool-kit on the end of the main shaft and rotate in a counter-clockwise direction to manually cycle the press through one revolution. The ram moves up and down one stroke and crimps the terminal.



Step 4

Remove the hand-crank, close the belt cover and replace the cap head socket screw in the catch and tighten with the hexagon key.

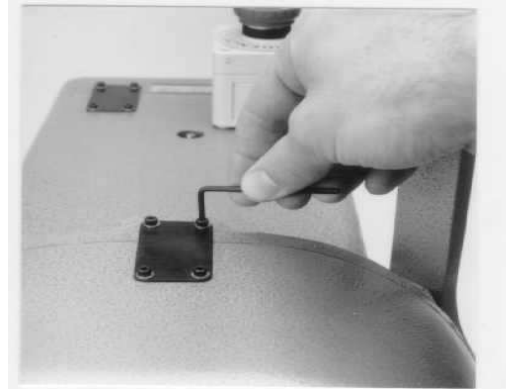

CAUTION Ensure that hand-crank is rotated through one complete revolution (until it physically stops). If the press is left part-way through a cycle it will try to complete the cycle when the motor is turned on and this action could result in damage being caused to the tooling.

5.2 OPERATION

Step 1

Connect the power supply cable and the foot-switch cable to the control box using the screw in connectors. Connect the power supply cable to the mains supply and switch on the press.

CAUTION

Ensure that the power supply cable is routed from the press safely and does not become trapped or chafed by any part of the crimping machine.



Step 2

Press the Ope. Light to the right to turn on the Operation Light.



Step 3

To count the number of crimped terminations, press the Reset push-button to set the counter display to 0.



Step 4

Check that neither of the function indicators is illuminated, then press the Power On push-button (green). The motor starts running.

NOTE: If a malfunction indicator is illuminated the motor will not start even if you press the Power On push-button.

ON



Step 5

Position a wire over the terminal and press the foot-switch once to activate it. The terminal is crimped and the next terminal is indexed along over the anvils ready for the next operation.



Step 6

When you finish using the press, turn off the Work-lamp and press the Power Off push-button.

OFF



CAUTION

If any problems occur during operations, immediately press the Power Off push-button and investigate the reason. If the problem requires the removal of safety guards, contact a person authorised to remove the guards. ON NO ACCOUNT REMOVE SAFETY GUARDS IF YOU ARE NOT AUTHORISED TO DO SO.

6. APPLICATOR ADJUSTMENT

6.1 Terminal Feed Position Adjustment.

CAUTION

The following adjustments require the removal of the safety guards and must only be carried out by authorized competent persons.

There is a risk of serious crushing injury in tooling exposed by the removal of the safety guards . Ensure that fingers are kept away from the moving parts of the applicator.

When using the MK-L Applicator

Adjust the terminal feed position to adjust the terminal crimping position. Before making this adjustment be sure that the applicator is mounted in the crimping machine correctly and the press ram is at Top Dead Centre.

Loosen the 5mm cap head socket screw and the knurled collar using a small length of silver steel or similar, as indicated on the photograph.

With the aid of the silver steel or a flat ended screw-driver rotate the adjustment shaft so that the feed-finger places the terminal in the correct position for crimping. Rotate the shaft counter-clockwise to move the terminal forward, and clock-wise to move it backwards.

When the adjustments are completed, tighten the knurled collar first followed by the cap screw.

Rotate the press through one revolution manually (see page 10), and check the resultant crimped terminal. If the appearance of the terminal is not correct repeat the above adjustment operation and check again.

When a satisfactory result is achieved, replace the guards, connect the crimping machine to the power supply and recommence the crimping operation.

When using the MKS-L Applicator

Adjust the terminal feed position to adjust the terminal crimping position. Before making this adjustment be sure that the applicator is mounted in the crimping machine correctly and the press ram is at Top Dead Centre.

To position a terminal at the centre of the die, follow the procedure below.

Loosen the 5mm cap head socket screw and the knurled collar using a small length of silver steel or similar, as indicated on the photograph.

With the aid of the silver steel or a flat ended screw-driver rotate the adjustment shaft so that the feed-finger places the terminal in the correct position for crimping. Rotate the shaft counter-clockwise to move the terminal to the right (forwards), and clock-wise to move it to the left (backwards).

When the adjustments are completed, tighten the knurled collar first followed by the cap screw.

Rotate the press through one revolution manually (see page 10), and check the resultant crimped terminal. If the appearance of the terminal is not correct repeat the above adjustment operation and check again.

When a satisfactory result is achieved, replace the guards, connect the crimping machine to the power supply and recommence the crimping operation.

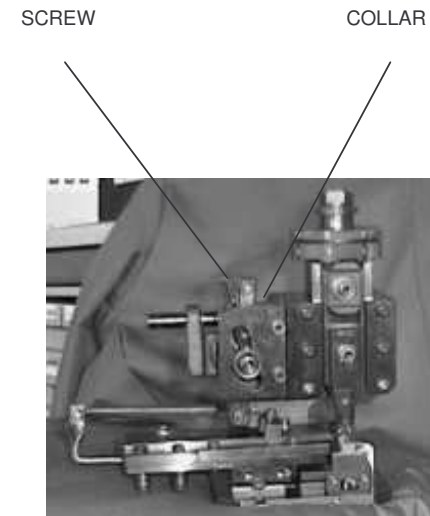
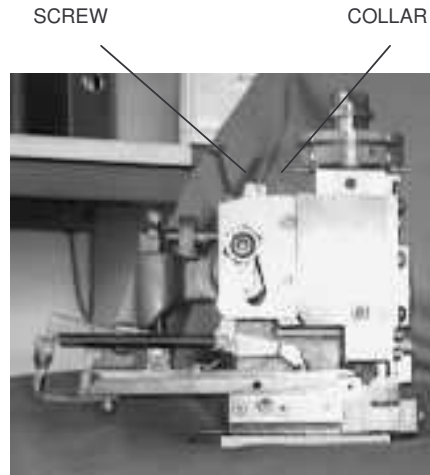

6.2 Bell Mouth Adjustment

When using the MK-L Applicator

Adjust the terminal feed position with reference to the bell-mouth position. Refer to section 6.1

When using the MKS-L Applicator (old type)

Move the entire feed-plate to obtain the desired bell-mouth crimp. First, loosen the feed-finger retaining screw in the feed-finger holder. Next, loosen the two cap head socket screws in the slots on the base of the applicator (see photograph).

With the aid of a flat ended screwdriver, rotate the adjusting screw in the front of the adjustment carriage, turn the screw clockwise to increase the bell-mouth (move the guide rails towards the front of the press), and counter-clockwise to decrease the bell-mouth (move the guide rails towards the back of the press).

Re-tighten the adjustment screws on the base of the applicator, centralize the feed-finger in the slot in the guide rail and tighten the screw.

Check the bell-mouth on the resultant crimp and re-adjust if necessary.

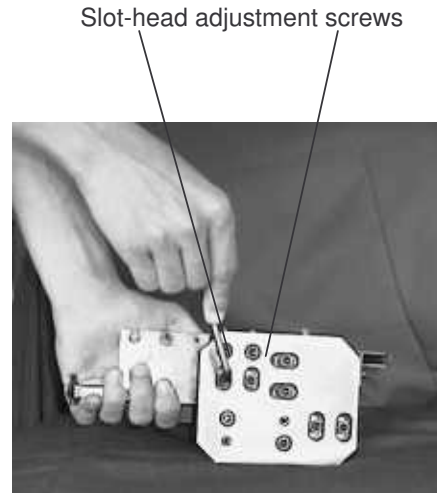

Feed-finger screw

Adjustment screw

When using the MKS-L Applicator (new type)

Move the entire feed-plate to obtain the desired bell-mouth crimp. First, loosen the feed-finger retaining screw in the feed-finger holder. Next, loosen the two hexagon-headed bolts situated on the front of the adjustment carriage just above the top surface of the applicator base-plate.

With the aid of a 5mm hexagon key, rotate the screw in the front of the adjustment carriage, turn the screw clockwise to decrease the bell-mouth (move the guide rails towards the back of the press), and counter-clockwise to increase the bell-mouth (move the guide rails towards the front of the press).

Re-tighten the adjustment bolts, centralize the feed-finger in the slot in the guide rail and tighten the screw.

Check the resultant crimp and re-adjust if necessary.

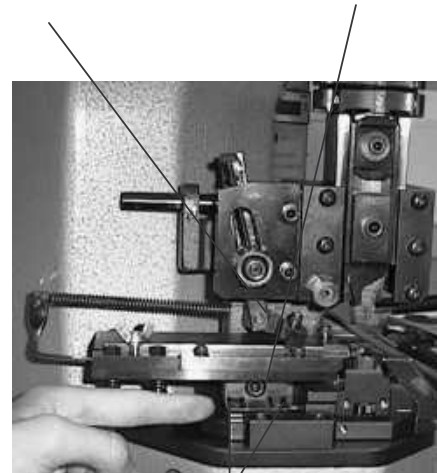

Hexagon nuts

There is a crimping manual available from the JST Technical Department detailing the points to inspect on a crimped terminal to achieve results as per our specifications.

A copy is issued with every AP-K2N Crimping machine supplied to a customer but please contact JST if you require further copies.

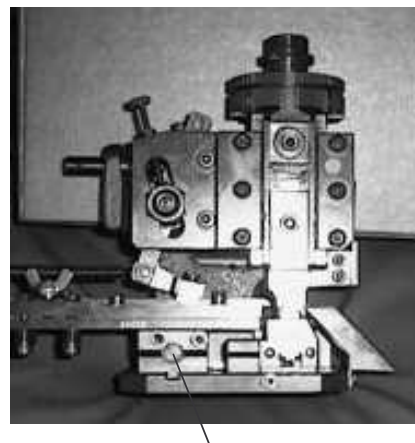

6.3 Feed-finger travel adjustment

Applicators are assembled and adjusted prior to despatch from JST and will not require adjustment by customers. Please contact JST Technical Services Department if you consider there is a problem with the Pitch setting adjustment.

6.4 Crimp Height adjustment

The applicator has two dials to adjust the insulation and wire crimp-height. The upper dial, marked with letters A - H, is for the wire (conductor), crimp-height. The lower dial, marked with numbers 1 - 8, is for the insulation crimp height.

JST do not advise pad settings for wire sizes, as is the practice of some manufacturers. We believe that the best method to adopt is to specify crimp-heights and adjust the dials until the desired crimp-height is achieved.

◻ Wire crimp-height (conductor) adjustment.

Setting the upper dial to graduation A produces the tightest crimp-height (lowest), and graduation H the least tight (highest). The crimp height alters by approximately 0.05mm per graduation, so a total range of adjustment of 0.40mm is attainable.

◻ Insulation crimp-height adjustment.

Setting the lower dial to graduation 1 produces the tightest crimp-height (lowest), and graduation 8 the least tight (highest). The crimp-height alters by approximately 0.10mm per graduation, so a total range of 0.80mm is attainable.

We do not state insulation crimp-heights due to the large variation of insulation types available. The insulation should be set as per instructed in the JST Crimping Manual supplied with the AP-K2N crimping machine. If you require further copies, please contact the JST Technical Services Department.

CAUTION

When initially installing the applicator in the press, ensure that the dials are set at H - 8 to avoid the possibility of tooling damage.

Always check the crimp-height of the terminal by use of a Crimp-height Micrometer because they are designed specifically for the purpose and indicate the true crimp-height. If you require details for the supply of a crimp-height micrometer please contact JST Technical Services Department.

If the applicator is not capable of achieving the desired crimp-height by adjusting the dials, please contact the JST Technical Services Department, because there is a range of blocks available to alter the range of crimp heights available. If you specify the blocks currently installed in your applicator (see 'Exploded view' supplied with applicator), we can advise you of the part no of the replacement blocks necessary to achieve the desired crimp-height.

Do not adjust the crimp-height by altering the shut-height of the AP-K2N press, because it is factory set and should only require occasional adjustment when serviced by the JST Service Engineer.

INSULATION CRIMP ADJUSTING DIAL
CONDUCTOR CRIMP ADJUSTING DIAL

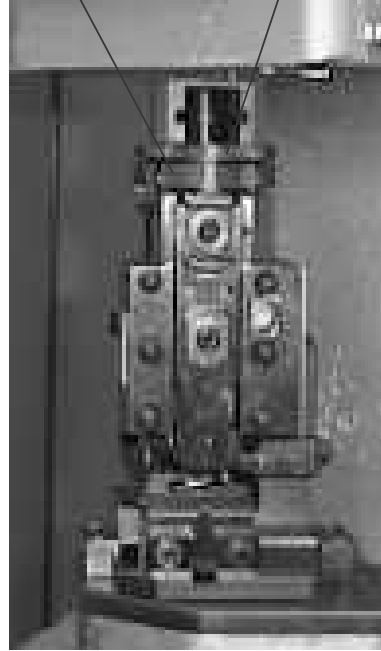

MK-L

INSULATION CRIMP ADJUSTING DIAL
CONDUCTOR CRIMP ADJUSTING DIAL

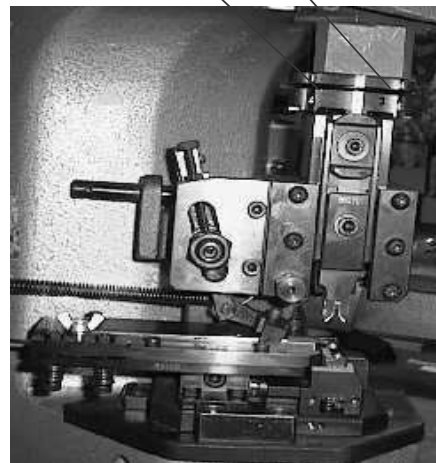

MKS-L

.5 Die Part Replacement

The crimping dies are consumable parts. When a die part becomes worn and requires replacement, check the part number engraved on the die part, or consult the 'exploded view' drawing supplied with every applicator and order a new part from JST technical Services Department.

If you consider that the replacement process is too difficult, or the tooling has sustained damage, please contact JST to either send back the tooling for repair or alternatively a JST Service Engineer can visit your company to repair the tool on site.

6.6 Lubrication of Applicator

Periodically lubricate the surfaces indicated on the photographs with grease. A general purpose grease obtainable from Garages or car accessory shops is suitable.

Remove the ram from the applicator body and apply the grease to the cam surface.

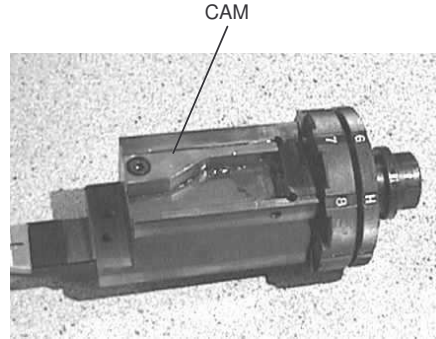

Apply grease to the surface of the cam-roller.

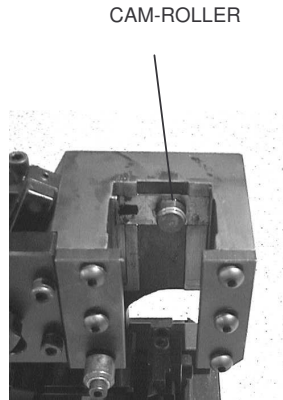

APPLY GREASE HERE

Apply grease to the four faces of the applicator ram.

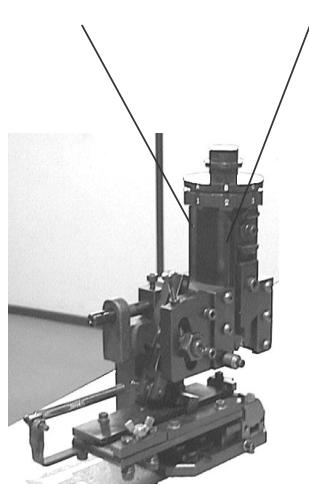

CAUTION

Apply grease sparingly because excess grease attracts dirt and scrap insulation etc.

7. CRIMPING MACHINE MAINTENANCE

CAUTION

Disconnect the Power Cable from the mains supply before carrying out any maintenance operations on the Crimping Press.

7.1 Lubrication

MAIN SHAFT BEARING

Lightly grease the main-shaft bearing once a year using a general purpose grease, eg Castrol LM.

RAM SECTION

Remove the cap head socket screws from the ram cover and add a few drops of machine oil to the felt pads in the three oiling holes once a week.

CLUTCH SECTION

Remove the cap head socket screws from the belt-cover catch and open the cover. Add a few drops of oil to the oiling points indicated on the photograph.

NOTE: The frequency of lubrication is dependant on the use of the machine. Do not apply excessive lubrication because the oil may drip through onto the applicator and contaminate the terminals.

ROLLER CLUTCH

Step 1

Slowly rotate the fly-wheel whilst pulling the V-belts to the side to remove them.

CAUTION

ENSURE THAT FINGERS DO NOT BECOME TRAPPED BETWEEN THE V-BELT AND THE FLY-WHEEL

Step 2

With the aid of a pair of internal circlip pliers, remove the circlip retaining the fly-wheel.

MAIN SHAFT BEARING GREASING LOCATION

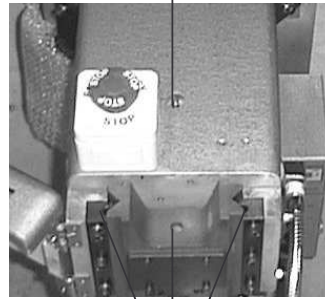

RAM SECTION OILING LOCATIONS

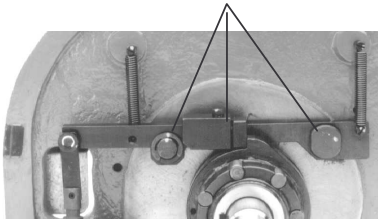

CLUTCH SECTION OILING LOCATIONS

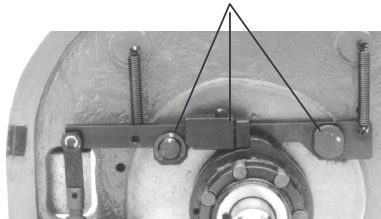

Step 3

Firmly grip the fly-wheel on both sides and pull off the end of the shaft. There are seven 'stick rollers' inside the clutch and they may fall out when the fly-wheel is pulled off the shaft, so take care not to lose any.



Step 4

Remove any traces of old grease from all components of the clutch mechanism and sparingly lubricate all the clutch components with fresh grease.

Specified Grease: Multemp PS no.1 manufactured by Kyodo Yushi Co Ltd.

Do not use general purpose grease because the clutch will not function correctly.

Contact JST Technical Services Department for details of grease stockists.

Step 5

Assemble the clutch ensuring that the clutch lever is engaged correctly with the clutch cam, as in photo A.



PHOTO A

If the clutch is assembled as in photo B, it will not be possible to re-mount the flywheel onto the shaft.



PHOTO B

7.2 Inspection and Repair

RAM STABILITY

Approximately every six months physically check that the ram is not loose.

To check the ram, remove the screws from the catch and open the cover.

Grip the ram firmly and try to move the ram from side to side. It is also possible to detect whether the ram is loose by the noise it makes when crimping, and also the measured crimp height of the terminal may become unstable.

° **Adjustment Procedure**

Step 1

Remove the two dome-nuts from the side wall of the ram.

Step 2

Loosen the three cap head screws on the right hand side of the adjustable ram guide.

Step 3

Fasten the grub screws on the ram guide finger-tight so that you can manually move the ram up and down by hand, but it does not drop under its own weight. Next, check that the ram does not wobble and that it moves smoothly.

Make a final check check that the ram is stable and the screws are secure. Replace cap head screws in ram cover.

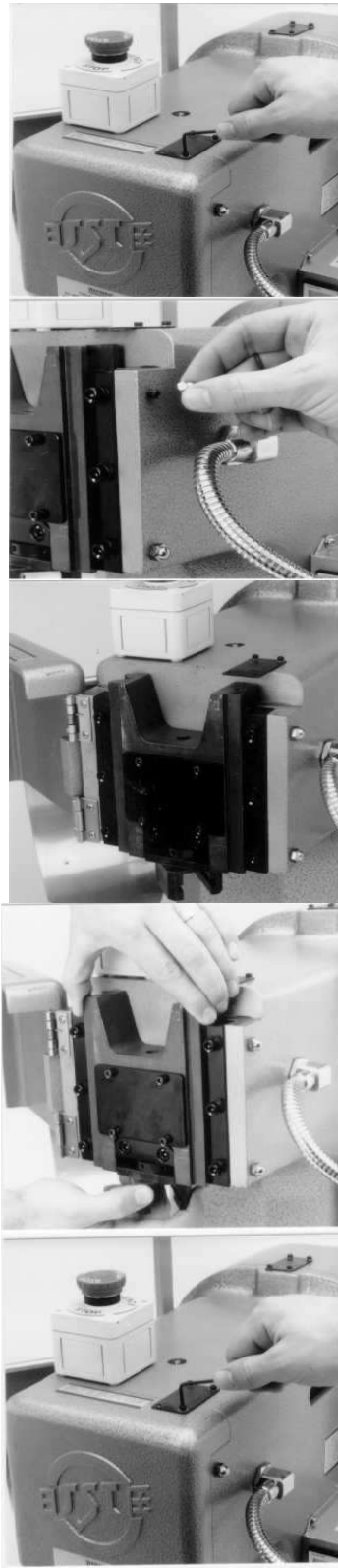

□ Positioning of the Solenoid Bracket

Once a year remove the cap head screws from the catch on the belt cover and open the cover. Check that the clearance is correct as shown on the photograph. The clearance should be 6 - 7mm, if it varies from this dimension adjust the bracket in the following manner:-

Loosen the two cap head screws holding the bracket to the press casting and move the solenoid up or down until the correct clearance is obtained. Tighten the cap head screws on the retaining bracket, close the belt cover and replace the socket screws in the bracket.

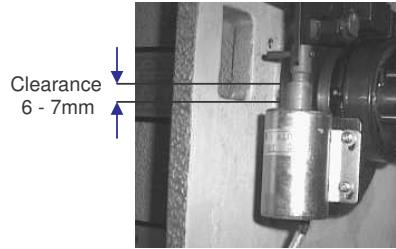

8. FAULT-FINDING

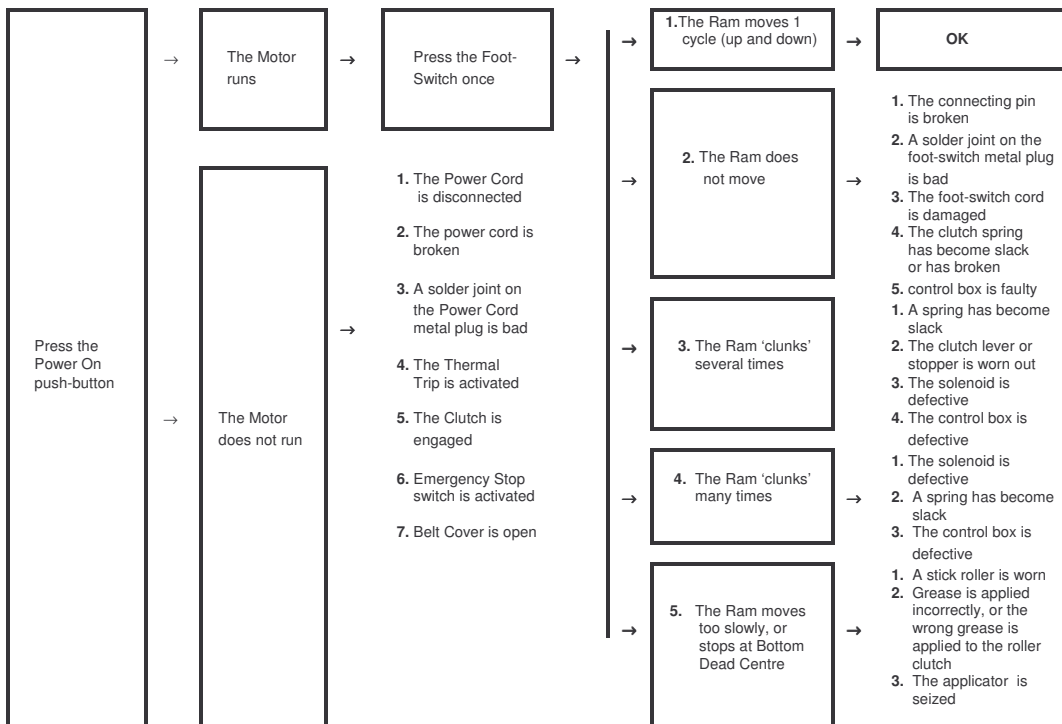

1. The Motor does not run

- (1) **The Power cord is disconnected**
reconnect the power cord.
- (2) **The Power cord is damaged**
replace the power cord



- (3) **A solder joint on the Power Cord metal plug is bad**
Resolder the joint

- (4) **The Thermal Trip is activated**
Press in the thermal trip push-button. If the thermal trip has activated, wait one minute or more before resetting. Consult the JST Technical Department if the thermal trip activates frequently.



- (5) **The Emergency Stop switch is activated**
Reset by turning the switch clockwise

- (6) **The Belt Cover is open**
Close the belt cover and re-secure the catch with the cap head socket screws.



2. The Ram does not move

- (1) **The Connecting Pin is broken**
Replace the connecting pin with a new one.
Connecting pin

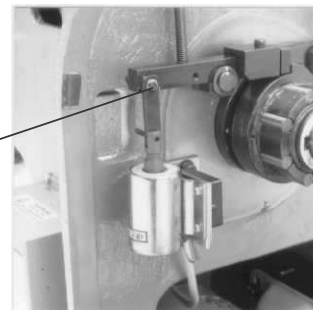

- (2) **A solder joint on the Foot-Switch metal plug is bad**
Resolder the joint



- (3) **The Foot-Switch cord is damaged**
Replace the Foot-Switch cord with a new one.
Connect the micro-switch to the plug as per the illustration.

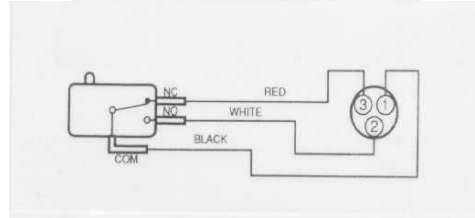

- (4) **The Clutch Spring has become slack or has broken**
Replace the spring with a new one.
- (5) **The Control Box is faulty**
The Control Box requires repair. Contact the JST Technical Services Department for assistance.

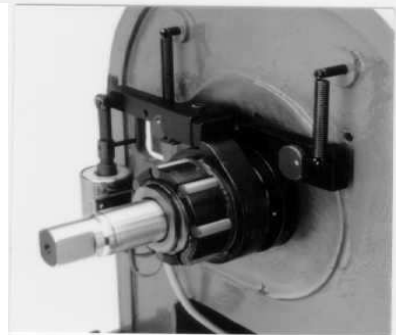

3. The Ram 'clunks' several times

- (1) **A Spring has become slack**
Replace the spring with a new one.

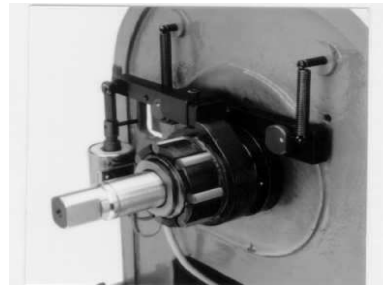

- (2) **The Clutch Lever or Stopper is worn out**
Replace parts with new ones.



- (3) **The Solenoid is defective**
Adjust the relationship between the solenoid piston and cylinder by moving the solenoid cylinder back or forth on the solenoid bracket.



- (4) **The Control Box is defective**
The control box requires repair. Contact the JST Technical Services Department for assistance.

4. The Ram 'clunks' many times

- (1) **The Solenoid is defective**
Refer to 3-(3) above.
- (2) **A Spring has become slack**
Replace the spring with a new one, see 3-(1).
- (3) **The Control Box is defective**
The control requires repair. Contact JST Technical Services Department for assistance.

5. The Ram moves too slowly, or stops at Bottom Dead Centre

- (1) **A Stick Roller is worn out**
Replace the stick rollers with new ones. Always replace the rollers as a set of seven. Oversize rollers are available from JST to extend the service life of the clutch. Please contact the Technical Services Department for details.
- (2) **Grease is applied incorrectly, or the wrong grade of grease has been used**
Clean the clutch and reapply the correct grade of grease. See section 7 for details of grease specification.
- (3) **The Applicator is seized**
Contact the JST Technical Services Department for assistance.
- (4) **Part of the Clutch assembly is missing**
Check that all the Stick Rollers are assembled.