



Chipsmall Limited consists of a professional team with an average of over 10 year of expertise in the distribution of electronic components. Based in Hongkong, we have already established firm and mutual-benefit business relationships with customers from,Europe,America and south Asia,supplying obsolete and hard-to-find components to meet their specific needs.

With the principle of “Quality Parts,Customers Priority,Honest Operation,and Considerate Service”,our business mainly focus on the distribution of electronic components. Line cards we deal with include Microchip,ALPS,ROHM,Xilinx,Pulse,ON,Everlight and Freescale. Main products comprise IC,Modules,Potentiometer,IC Socket,Relay,Connector.Our parts cover such applications as commercial,industrial, and automotives areas.

We are looking forward to setting up business relationship with you and hope to provide you with the best service and solution. Let us make a better world for our industry!



Contact us

Tel: +86-755-8981 8866 Fax: +86-755-8427 6832

Email & Skype: info@chipsmall.com Web: www.chipsmall.com

Address: A1208, Overseas Decoration Building, #122 Zhenhua RD., Futian, Shenzhen, China



MODELS APLRI - APOLLO TIME INTERVAL RATE INDICATOR

- OPERATES ON LOW INPUT RATES
- 6-DIGIT, 0.56" (14.2 mm) HIGH LED DISPLAY
- COUNT RATES UP TO 10 KHz
- EASY SELECTION OF RATE MULTIPLIER
- PROGRAMMABLE INPUT CIRCUIT, ACCEPTS OUTPUTS FROM A WIDE VARIETY OF SENSORS
- LEADING ZERO BLANKING
- PROGRAMMABLE DECIMAL POINTS
- 0.02% ACCURACY
- EIGHT PULSE MOVING WINDOW AVERAGE
- NEMA 4/IP65 SEALED FRONT PANEL METAL BEZEL



DESCRIPTION

The Apollo Time Interval Rate Indicator provides the capability of measuring very slow input rates and scaling these low rates in terms of a readily usable and recognizable engineering unit (i.e. bottles/min., rolls/hr., cases/shift, barrels/day, etc.). The APLRI measures the time (with crystal controlled accuracy) between input pulses, inverting this measured time, then multiplying it by the programmed scale multipliers set by the rear panel DIP switches.

The unit can also accommodate magnetic pickups, logic sensors, and NPN open collector sensors, as well as switch contact closure sensors.

The unit has a self-test feature, which checks all the microprocessor and display driver circuitry after power-up, if enabled. This self-test can also be used to test the multiplier select DIP switches and decimal point select DIP switches, to make certain all switches are functioning properly.

Power and input connections are made via a removable terminal block, located at the rear of the unit. Each terminal can accept one #14 AWG wire. DIP switches at the side of the unit are used to program the input configuration.

The APLRI has a sealed metal die-cast bezel which meets NEMA 4/IP65 specifications for wash-down and/or dust, when properly installed. The APLRI has a 6-digit, 0.56" high LED display, which is readable to 23 feet (7 M).

SAFETY SUMMARY

All safety related regulations, local codes and instructions that appear in the manual or on equipment must be observed to ensure personal safety and to prevent damage to either the instrument or equipment connected to it. If equipment is used in a manner not specified by the manufacturer, the protection provided by the equipment may be impaired.

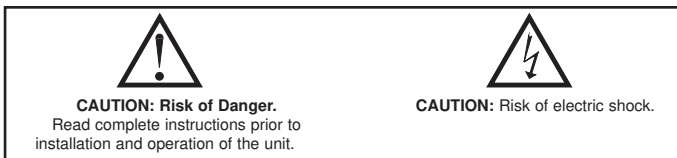

SPECIFICATIONS

- DISPLAY:** 6-Digit, 0.56" (14.2 mm) High Red LED's.
- POWER REQUIREMENTS:**
AC Operation: 115 VAC, ±10%, 50/60 Hz, 14 VA
DC Operation: 24 VDC, 10% @ 0.6 A max.
Note: All available units can be powered at Terminal #3 from an 11 to 14 VDC, 0.6 mA max. power supply.
- SENSOR POWER:** +12 VDC, ±25% @ 100 mA max.
- OPERATING FREQUENCY RANGE:** 0.1 pulse/sec. to 10,000 pulses/sec. in the rate per second mode. 0.36 pulses/min. to 600,000 pulses/min. in the rate per minute mode.
Note: When the value to be displayed exceeds the full scale display capacity, six dashes are displayed. Also if the display input is too low, the unit will display a zero.
- ACCURACY AND REPEATABILITY:** 0.02%
- RATE MULTIPLIER INCREMENT TOTAL, SELECTION RANGE:** From 1 to 8191.
- DISPLAY UPDATE TIME:** The display will update every 0.65 sec. plus one input pulse when the input pulse rate is 1.54 pulses/sec. or higher. When the input pulse rate is below 1.54 pulses/sec. the display will update on every input pulse.
Note: When the input pulse rate is 3 pulses/sec. or lower, the unit will utilize, if selected, a technique known as a "moving window average". (This continually averages the last eight input pulses.)
- MAXIMUM INPUT VOLTAGE AND CURRENT:** When the "SIG. IN" (Terminal 5) is driven from external signal voltages, maximum voltage swing is ±50 V peak. Input voltage can be dropped by an external series resistance that limits input current to ±5 mA. (These ratings are for S3 "OFF".)
- INPUT IMPEDANCE:** With S1 and S3 "OFF", the resistive input impedance exceeds 1megohm as long as the "SIG. IN" (Terminal 5) input voltage is between zero and +12 VDC. Beyond these levels, the high and low clamping diode will start to conduct, thus decreasing the input impedance. With S3 "ON" the maximum input voltage to Terminal 5 must be limited to 28 VDC.

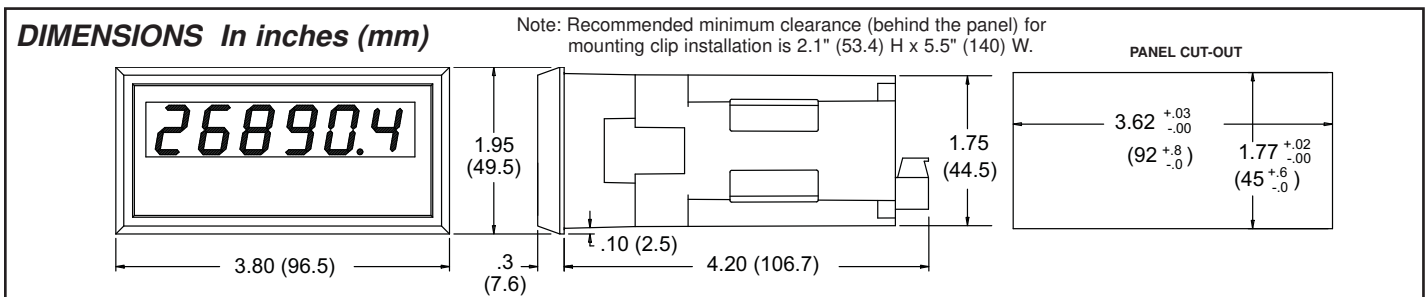

SPECIFICATIONS (Con't)

10. PARALLELING WITH APOLLO TOTALIZER (RLC standard count input) INPUTS: Apollo Rate Indicators may be parallel connected with counters having the RLC standard count input circuitry. These can operate from a common current sink or source sensor, by connecting the appropriate terminals in common. S3 on the Rate Indicator should be turned "OFF" since pull-up or pull-down resistors are already present in the counter. The Rate Indicator will not add appreciable sensor load with this arrangement.

Note: Rate Indicators cannot be operated in parallel with standard input counters when 2-wire proximity sensors are used.

11. INPUT AND POWER CONNECTIONS: There is a plug-in, compression-type, terminal block located at the rear of the unit. This block can be removed from the rear of the unit for ease of wiring. After wiring is complete, the connector can be plugged back onto the unit.

12. CERTIFICATIONS AND COMPLIANCES:

CE Approved

EN 61326-1 Immunity to Industrial Locations
Emission CISPR 11 Class A
IEC/EN 61010-1
RoHS Compliant

Type 4X Outdoor Enclosure rating (Face only)

IP65 Enclosure rating (Face only)

IP20 Enclosure rating (Rear of unit)

Refer to EMC Installation Guidelines section of the bulletin for additional information.

13. ENVIRONMENTAL CONDITIONS:

Operating Temperature: 0 to 50°C

Storage Temperature: -40 to 70°C

Operating and Storage Humidity: 85% max. relative humidity (non-condensing) from 0°C to 50°C.

Altitude: Up to 2000 meters

14. CONSTRUCTION: Die-cast metal front bezel with black, high impact plastic insert. Front panel meets NEMA 4/IP65 requirements for indoor use when properly installed. Installation Category II, Pollution Degree 2. (Panel gasket and mounting clip included with unit.)

15. WEIGHT: 1.5 lbs. (0.8 Kgs)

INPUT SET-UP

The selection of input set-up is accomplished by the first three of six DIP switches, located along the side of the unit. DIP switches 1-3 are used to configure the input. Each of these switches are discussed below.

Note: Rate indicators frequently use magnetic pickups for input devices.

Consequently, there are basic differences between counter and rate-indicator input circuits. In the APLRI input circuit, the hysteresis level is quite small and the bias levels are significantly different to accommodate both magnetic pickup inputs, as well as the +5 V and higher logic levels.

S1 - ON [MAG.PKUP.]: Connects a 0.1 µf damping input capacitor from input to common. This capacitor is used mostly with magnetic pickup inputs and serves to filter out high frequency noise. It can also be used to filter switch contact closures.

Note: If excessive contact "bounce" is encountered, an additional external filter capacitor may be necessary. Reed switches, mercury wetted contacts, snap action limit switches, and silver alloy relay contacts with wiping action are usually satisfactory for generating count input signals. Motor starter contacts, tungsten contacts, and brush-type contacts should not be used.

S2 - ON [LOGIC]: Sets the bias reference so that input logic signals trigger count pulses as they cross a level of approximately +2.5 V.

OFF: Sets the bias reference so that a signal of 150 millivolts or more will trigger count pulses. This provides the sensitivity required for low speed magnetic pickup sensors.

Note: Hysteresis for both S2 "ON" and "OFF" conditions is about 25 millivolts. This means the difference between V_{IL} and V_{IH} with logic inputs (S2) is almost insignificant and only a very small swing about the 2.5V bias level will trigger the input.

S3 - ON [NPN O.C.]: Connects a 3.9 KΩ pull-up load resistor for sensors or circuits with current sink outputs. The sensor output must sink 4 mA @ V_{OL} of 1 V or less. Unlike the time base rate indicator, the APLRI units can work with switch contact closures because of the low count rate capability. S1 should be closed when switch contact closures are used as inputs to the unit.

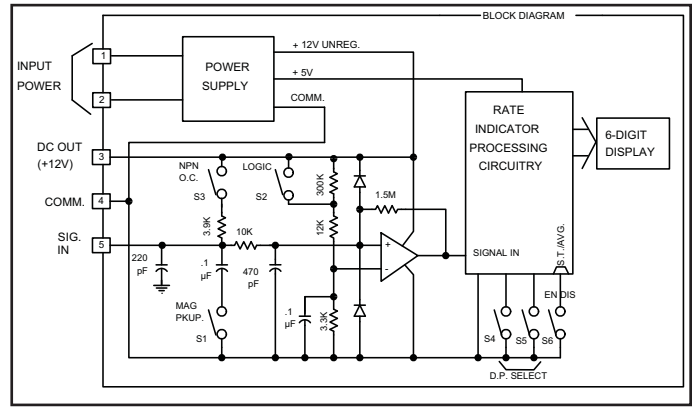

DECIMAL POINT SELECTION

The selection of Decimal Point is accomplished by DIP switches 4 and 5. The table at the right shows what combination of switches is needed to obtain the desired decimal point location. The unit always has leading zero blanking. *Note: D.P. will change only at the normal display update time of the unit.*

SW 4	SW 5	D.P. LOCATION
↓ (0)	↓ (0)	0
↑ (1)	↓ (0)	0.0
↓ (0)	↑ (1)	0.00
↑ (1)	↑ (1)	0.000

MOVING WINDOW AVERAGING & SELF-TEST

DIP switch 6, the S.T./AVG. switch, serves a dual function of disabling or enabling the "MOVING WINDOW AVERAGE" (MWA) function and the self-test function. When the switch is "UP", MWA and the self-test are both disabled. When the switch is "DOWN", MWA and self-test are both enabled.

MOVING WINDOW AVERAGING

This allows the unit to "collect" and average the last eight input pulses which is continually updated whenever a new pulse occurs. The oldest input data is discarded and replaced with the newest data.

SELF-TEST

This unit has a built-in self-test feature which can only be activated immediately after power-up (the unit will not count while in self-test). To activate self-test, set the S.T./AVG. DIP switch (D.S. 6) to the enable position. Then power the unit up. With this test, all digits are cycled through starting with a string of six zeros. This will be shown for about half a second, then a string of ones will appear for about the same time duration. Following these, a string of twos and so on, up to nines will be displayed. After this portion, an interlace pattern of 1, 0, 1, 0, 1, 0, then 1, 2, 1, 2, 1, 2, and so on, until all digits from zero to nine have been displayed.

The next portion of self-test will display four groups of zeros and/or ones. (The first two digits from the left, in each group, will always show a zero.) In the first group, the third digit represents the 13th (x4096) DIP switch setting. The fourth and fifth digits show the setting for the Decimal Point select DIP switches. (The fourth position digit represents DIP switch 4 and the fifth position digit represents DIP switch 5.) The state of these digits coincides with the table listed under the "Decimal Point Selection" section.

The last digit will always show a one. The next three groups are shown on the right, and correspond to the DIP switch shown directly above it. *Note: The first two digits in each group are always shown as zeros.*

			9	10	11	12 (DIP SWITCH)
Group 2:	0	0	X	X	X	X
			5	6	7	8 (DIP SWITCH)
Group 3:	0	0	X	X	X	X
			1	2	3	4 (DIP SWITCH)
Group 4:	0	0	X	X	X	X

The X's represent a zero or one (depending on the setting of the DIP switch) in the display. Self-test is automatically exited 8 seconds after the last DIP switch is changed.

EMC INSTALLATION GUIDELINES

Although Red Lion Controls Products are designed with a high degree of immunity to Electromagnetic Interference (EMI), proper installation and wiring methods must be followed to ensure compatibility in each application. The type of the electrical noise, source or coupling method into a unit may be different for various installations. Cable length, routing, and shield termination are very important and can mean the difference between a successful or troublesome installation. Listed are some EMI guidelines for a successful installation in an industrial environment.

1. A unit should be mounted in a metal enclosure, which is properly connected to protective earth.
2. Use shielded cables for all Signal and Control inputs. The shield connection should be made as short as possible. The connection point for the shield depends somewhat upon the application. Listed below are the recommended methods of connecting the shield, in order of their effectiveness.
 - a. Connect the shield to earth ground (protective earth) at one end where the unit is mounted.
 - b. Connect the shield to earth ground at both ends of the cable, usually when the noise source frequency is over 1 MHz.
3. Never run Signal or Control cables in the same conduit or raceway with AC power lines, conductors, feeding motors, solenoids, SCR controls, and heaters, etc. The cables should be run through metal conduit that is properly grounded. This is especially useful in applications where cable runs are long and portable two-way radios are used in close proximity or if the installation is near a commercial radio transmitter. Also, Signal or Control cables within an enclosure should be routed as far away as possible from contactors, control relays, transformers, and other noisy components.
4. Long cable runs are more susceptible to EMI pickup than short cable runs.
5. In extremely high EMI environments, the use of external EMI suppression devices such as Ferrite Suppression Cores for signal and control cables is effective. The following EMI suppression devices (or equivalent) are recommended:

Fair-Rite part number 0443167251 (RLC part number FCOR0000)

Line Filters for input power cables:

Schaffner # FN2010-1/07 (Red Lion Controls # LFIL0000)

6. To protect relay contacts that control inductive loads and to minimize radiated and conducted noise (EMI), some type of contact protection network is normally installed across the load, the contacts or both. The most effective location is across the load.
 - a. Using a snubber, which is a resistor-capacitor (RC) network or metal oxide varistor (MOV) across an AC inductive load is very effective at reducing EMI and increasing relay contact life.
 - b. If a DC inductive load (such as a DC relay coil) is controlled by a transistor switch, care must be taken not to exceed the breakdown voltage of the transistor when the load is switched. One of the most effective ways is to place a diode across the inductive load. Most RLC products with solid state outputs have internal zener diode protection. However external diode protection at the load is always a good design practice to limit EMI. Although the use of a snubber or varistor could be used.
RLC part numbers: Snubber: SNUB0000
Varistor: ILS11500 or ILS23000
7. Care should be taken when connecting input and output devices to the instrument. When a separate input and output common is provided, they should not be mixed. Therefore a sensor common should NOT be connected to an output common. This would cause EMI on the sensitive input common, which could affect the instrument's operation.

Visit RLC's website at <http://www.redlion.net/Support/InstallationConsiderations.html> for more information on EMI guidelines, Safety and CE issues as they relate to Red Lion Controls products.

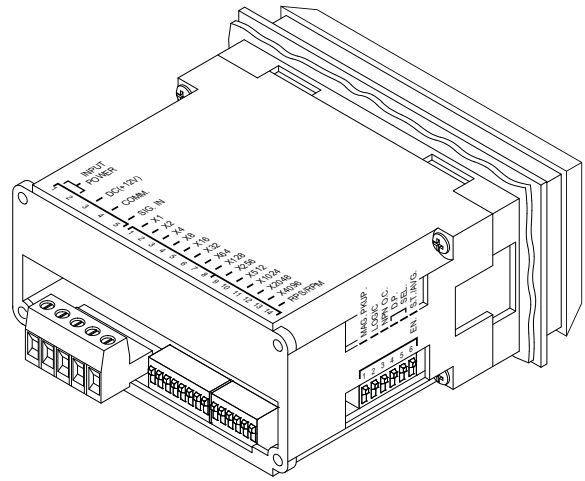

WIRING CONNECTIONS

As depicted in the drawing showing the rear view of the Apollo Time Interval Rate Indicator, there is a terminal block where all wiring connections are made. All conductors should meet voltage and current ratings for each terminal. Also cabling should conform to appropriate standards of good installation, local codes and regulations. It is recommended that power supplied to the unit (AC or DC) be protected by a fuse or circuit breaker. Remove the block for easy access to the terminal screws. To remove the block, pull from the back of the block until it slides clear of the terminal block shroud.



CAUTION: The terminal block should NOT be removed with power applied to the unit.

Terminal 3 is the "DC" (+12 V) terminal. This terminal is for sensor supply and can provide up to 100 mA of current. An external +11 V to +14 VDC can also be applied to this terminal to power the unit in the absence of A.C. power.

Terminal 4 is the "COMM." (common) terminal, which is the common line to which the sensor and other input commons are connected.

Terminal 5 is the "SIG. IN" (signal in) terminal. When the signal at this terminal goes low, a count will be registered in the unit. (See "Input Ratings" under "Specifications" section.)

POWER WIRING (A.C. Version)

Primary AC power is connected to Terminals 1 and 2 (marked VAC 50/60 Hz, located on the left-hand side of the block). For best results, the AC power should be relatively "clean" and within the specified $\pm 10\%$ variation limit. Drawing power from heavily loaded circuits or from circuits that also power loads that cycle on and off, should be avoided.

POWER WIRING (APLRI D.C. Version only)

The DC Version unit will operate from a 24 VDC power supply. The positive wire of the DC power source connects to Terminal #1 and the minus "-" to Terminal #2.

INSTALLATION ENVIRONMENT

The unit should be installed in a location that does not exceed the maximum operating temperature and provides good air circulation. Placing the unit near devices that generate excessive heat should be avoided.

The bezel should be cleaned only with a soft cloth and neutral soap product. Do NOT use solvents. Continuous exposure to direct sunlight may accelerate the aging process of the bezel.

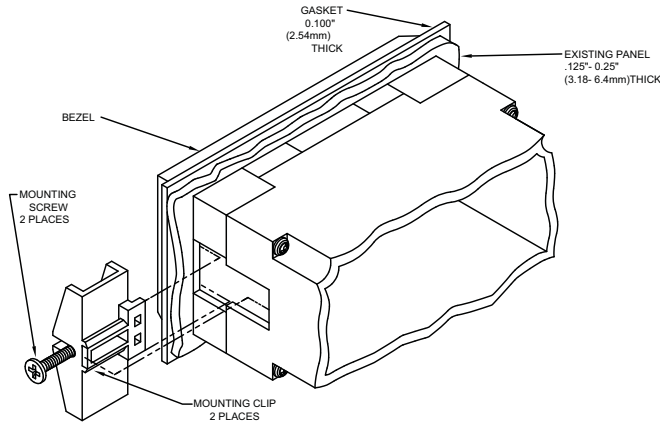

INSTALLATION

The unit meets NEMA 4/IP65 requirements for indoor use when properly installed. The units are intended to be mounted into an enclosed panel. Two mounting clips and screws are provided for easy installation. Consideration should be given to the thickness of the panel. A panel which is too thin may distort and not provide a water-tight seal. (Recommended minimum panel thickness is 1/8".)

Cut the panel opening to the specified dimensions. Remove burrs and clean around the panel opening. Slide the panel gasket over the rear of the unit to the back of the bezel. Insert the unit into the panel cutout.

As depicted in the drawing, install the screws into the narrow end of the mounting clips. Thread the screws into the clips until the pointed end just protrudes through the other side. Install each of the mounting clips by inserting the wide lip of the clips into the wide end of the hole, located on either side of the case. Then snap the clip onto the case.

Tighten the screws evenly to apply uniform compression, thus providing a water-tight seal. **CAUTION:** Only minimum pressure is required to seal panel. Do **NOT** overtighten screws.

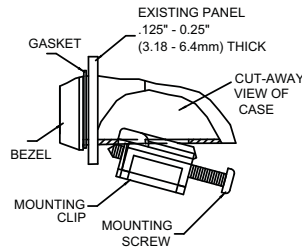

REAR PANEL DIP SWITCHES

As can be seen from the rear panel of the unit, there is a row of 14 DIP switches located beside the input and power terminal block. DIP switches 1 through 13 are Rate Multiplier Increment Total (RMIT) switches. When the switch is "ON", it will multiply the input rate by the rate multiplier value it represents.

DIP switch 14 is the Rate Per Second (RPS)/Rate Per Minute (RPM) DIP switch. When the switch is "OFF", the unit is set up for input pulse rate in RPS. When the switch is "ON", the unit is set up for input pulse rate in RPM. In actuality, the RPS/RPM switch is a x 60 multiplier (It will multiply the input rate by a value of 60). In other words, if the input pulse rate is known per second, and the rate lies between .1 pulses/sec. and 10,000 pulses/sec., set DIP switch 14 to RPS. If the input pulse rate is known per minute, and the rate lies between 0.36 pulses/min. and 600,000 pulses/min., set DIP switch 14 to RPM.

RATE MULTIPLIER SELECTION PROCEDURE

The APLRI has a rate multiplier selection range from 1 to 8191. For the minimum scaled reading (direct readout of the input rate), the x1 DIP switch would be set to "ON". For the maximum scaled reading (8191 times the input rate), all of the rear panel RMIT DIP switches would be turned "ON". Therefore, a specific Rate Multiplier Increment Total is achieved by adding up the appropriate individual rate multiplier values.

The rate multiplier increment total is computed according to the following formula:

$$\text{RATE MULTIPLIER INCREMENT TOTAL (RMIT)} = \frac{\text{Display Readout Desired}}{\text{(Known Input Pulse Rate)*}}$$

* - Input Pulse Rate Per Second (set RPS/RPM switch to RPS) or Input Pulse Rate Per Minute (set RPS/RPM switch to RPM).

EXAMPLE 1:

DISPLAY READOUT DESIRED = 4700
KNOWN INPUT PULSE RATE = 3PPS
RPS/RPM set to RPS

$$\text{RMIT} = \frac{4700}{3} = 1566.66 \left[\begin{array}{l} \text{round to the nearest} \\ \text{whole number} \end{array} \right] = 1567$$

The appropriate rate multiplier switches, which together add up to 1,567 are then set "ON".

Start by selecting the first increment which is greater than half the desired RMIT, and add subsequent increments that are more than half the difference needed.

$$\text{RMIT} = 1,567$$

DIP switch 11	-	1024	Needed =	543
DIP switch 10	-	512	Needed =	31
DIP switch 5	-	16	Needed =	15
DIP switch 4	-	8	Needed =	7
DIP switch 3	-	4	Needed =	3
DIP switch 2	-	2	Needed =	1
DIP switch 1	-	1		

If the input pulse rate was known in Rate Per Minute (60 x RPS), the RPS/RPM switch would be set to RPM and the calculations would be as follows.

$$\text{RMIT} = \frac{4700}{180} = 26.11 \left[\begin{array}{l} \text{round to the nearest} \\ \text{whole number} \end{array} \right] = 26$$

DIP switch 5	-	16	Needed =	10
DIP switch 4	-	8	Needed =	2
DIP switch 2	-	2		

Therefore, DIP switches 2, 4, and 5, would be set to "ON", and the RPS/RPM DIP switch would be switched to "RPM".

EXAMPLE 2:

DISPLAY READOUT DESIRED = 432,000 bolts per day
INPUT PULSE RATE PER SECOND = 5 bolts (pulses) per sec.

Since the value to be displayed in this example is so large, the input rate was converted to rate per minute (5 x 60 = 300 BPM) and the RPS/RPM switch was set to RPM. The following calculations were performed:

$$\text{RMIT} = \frac{432,000}{300} = 1440$$

DIP switch 11	-	1024	Needed =	416
DIP switch 9	-	256	Needed =	160
DIP switch 8	-	128	Needed =	32
DIP switch 6	-	32		

Therefore, DIP switches 6, 8, 9, 11, and 14 (RPS/RPM DIP switch) would be turned "ON".

CONNECTIONS & CONFIGURATION SWITCH SET-UP FOR VARIOUS SENSOR OUTPUTS

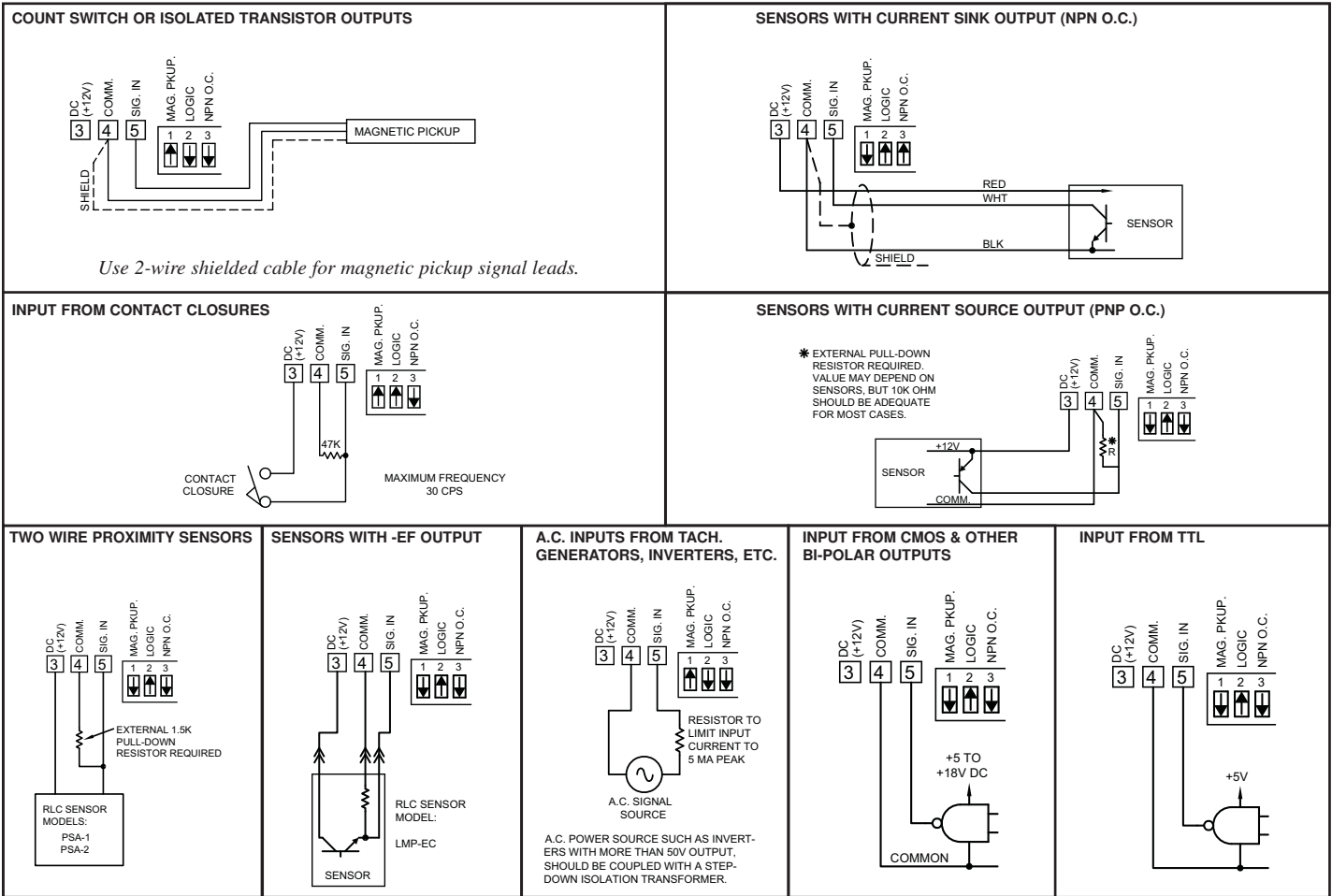

CRUDE OIL METER

BARRELS

CRUDE OIL

CONTACT CLOSURE 1 PULSE EVERY 5 SEC.

THESE SWITCHES ARE LOCATED ON THE SIDE OF THE UNIT

1 MAG. PKUP.
2 LOGIC
3 NPN O.C.
4 SEL.
5 EN I S T /AVG.

INPUT POWER
DC (+12V)
COMM.
SIG. IN
MAG. PKUP.
LOGIC
NPN O.C.

X1 X2 X3 X4 X5 X6 X7 X8 X9 X10 X11 X12 X13 X14

2.2µf

FLOW RATE INDICATION APPLICATION

An oil well can be pumped at a rate of one barrel of oil every 5 sec. The supervisor wants to know the rate in barrels per day (using the 1 barrel per 5 sec. as a consistent average), that the well is producing. Some calculations can determine what the display would read, in barrels/day.

$$\frac{1 \text{ barrel}}{5 \text{ sec.}} \times \frac{60 \text{ sec.}}{1 \text{ min.}} \times \frac{60 \text{ min.}}{1 \text{ hr.}} \times \frac{24 \text{ hr.}}{1 \text{ day}} = 17,280 \text{ barrels/day}$$

Because of the large value to be displayed, the input rate was converted to Rate per minute (1/barrel x 60 sec./1 min. = 12 barrels/min.) and the RPS/RPM switch was set to RPM.

$$\text{RMIT} = \frac{\text{Display Readout Desired} \times \text{D.P.}}{\text{(Known Input Pulse Rate)}}$$

$$\text{RMIT} = \frac{17,280}{12 \text{ barrels/min}} = 1440$$

DIP switch 11	1024	Needed =	416
DIP switch 9	256	Needed =	160
DIP switch 8	128	Needed =	32
DIP switch 6	32		

Therefore, DIP switch 6, 8, 9, 11, and 14 are all turned "ON".

SLOW TURNING SHAFT APPLICATION

The drawing shows one of the most common uses for the Model APLRI Time Interval Rate Indicator. This is a slow turning shaft without the capability of placing a gear on the end of the shaft (due to space limitations, size of shaft, etc.). A PSAC is used to sense the keyway which is the only means of picking up a signal from the shaft. The shaft turns at speeds from 0.5 RPM to 10 RPM with an average speed of 5 RPM. The foreman wants to know the rate, in cases of motor parts per shift, in which the assembly line is moving. At the average speed of the shaft, the display reading would be 1918 cases/shift. The formula is then used to figure out the required multiplier:

$$RMIT = \frac{\text{Display Readout Desired}}{\text{(Known Input Pulse Rate)}}$$

D.P. : Decimal Point

Use one of the following numbers in the above formula for the decimal point position.

- X1 = 0
- X10 = 0.0
- X100 = 0.00

DISPLAY READOUT DESIRED = 1918 cases/shift
 INPUT PULSE RATE = 5 PPM*

* Note: Since the input rate is in RPM, set the RPS/RPM switch to RPM. Also, since the input pulse rate could go below and usually is below 0.1 pulses/sec., the RPS/RPM switch must be set to RPM. Therefore,

$$RMIT = \frac{1918}{5} = 383.6 \left[\begin{array}{l} \text{round to the nearest} \\ \text{whole number} \end{array} \right] = 384$$

$$RMIT = 384$$

- DIP switch 9 - 256 Needed = 128
- DIP switch 8 - 128

DIP switches 8,9, and 14 are turned "ON".

If the rounding error introduced above is unacceptable, a decimal point and a times 10 multiplier value can be used to give a more exact reading.

$$RMIT = 383.6 \times 10 = 3836$$

$$RMIT = 3836$$

- DIP switch 12 - 2048 Needed = 1788
- DIP switch 11 - 1024 Needed = 764

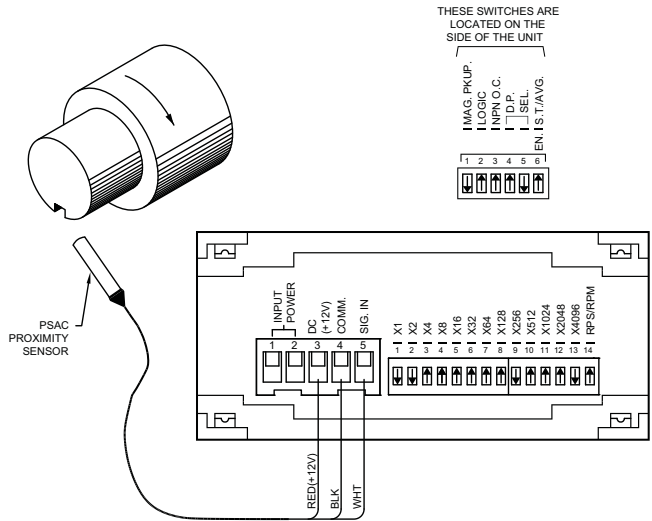

- DIP switch 10 - 512 Needed = 252
- DIP switch 8 - 128 Needed = 124
- DIP switch 7 - 64 Needed = 60
- DIP switch 6 - 32 Needed = 28
- DIP switch 5 - 16 Needed = 12
- DIP switch 4 - 8 Needed = 4
- DIP switch 3 - 4

Dip switches 3-8, 10-12, and 14 would be set to "ON". Also, the side panel DIP switch 4 would be set to "ON" to turn on the tenths position D.P. (Note: D.P. will only change at normal display update times.)

TROUBLESHOOTING

For further technical assistance, contact technical support at the appropriate company numbers listed.

ORDERING INFORMATION

MODEL NO.	DESCRIPTION	PART NUMBERS
APLRI	Apollo Time Interval Rate Indicator, 115 VAC	APLRI600
	Apollo Time Interval Rate Indicator, 24 VDC	APLRI630

This page intentionally left blank

LIMITED WARRANTY

The Company warrants the products it manufactures against defects in materials and workmanship for a period limited to two years from the date of shipment, provided the products have been stored, handled, installed, and used under proper conditions. The Company's liability under this limited warranty shall extend only to the repair or replacement of a defective product, at The Company's option. The Company disclaims all liability for any affirmation, promise or representation with respect to the products.

The customer agrees to hold Red Lion Controls harmless from, defend, and indemnify RLC against damages, claims, and expenses arising out of subsequent sales of RLC products or products containing components manufactured by RLC and based upon personal injuries, deaths, property damage, lost profits, and other matters which Buyer, its employees, or sub-contractors are or may be to any extent liable, including without limitation penalties imposed by the Consumer Product Safety Act (P.L. 92-573) and liability imposed upon any person pursuant to the Magnuson-Moss Warranty Act (P.L. 93-637), as now in effect or as amended hereafter.

No warranties expressed or implied are created with respect to The Company's products except those expressly contained herein. The Customer acknowledges the disclaimers and limitations contained herein and relies on no other warranties or affirmations.

Red Lion Controls
Headquarters
20 Willow Springs Circle
York PA 17406
Tel + 1 (717) 767-6511
Fax + 1 (717) 764-0839

Red Lion Controls
Europe
Softwareweg 9
NL - 3821 BN Amersfoort
Tel + 31 (0) 334 723 225
Fax + 31 (0) 334 893 793

Red Lion Controls
India
201-B, 2nd Floor, Park Centra
Opp 32 Mile Stone, Sector-30
Gurgaon-122002 Haryana, India
Tel +91 984 487 0503

Red Lion Controls
China
Unit 302, XinAn Plaza
Building 13, No.99 Tianzhou Road
ShangHai, P.R. China 200223
Tel +86 21 6113 3688
Fax +86 21 6113 3683