



Chipsmall Limited consists of a professional team with an average of over 10 year of expertise in the distribution of electronic components. Based in Hongkong, we have already established firm and mutual-benefit business relationships with customers from,Europe,America and south Asia,supplying obsolete and hard-to-find components to meet their specific needs.

With the principle of "Quality Parts,Customers Priority,Honest Operation,and Considerate Service",our business mainly focus on the distribution of electronic components. Line cards we deal with include Microchip,ALPS,ROHM,Xilinx,Pulse,ON,Everlight and Freescale. Main products comprise IC,Modules,Potentiometer,IC Socket,Relay,Connector.Our parts cover such applications as commercial,industrial, and automotives areas.

We are looking forward to setting up business relationship with you and hope to provide you with the best service and solution. Let us make a better world for our industry!



Contact us

Tel: +86-755-8981 8866 Fax: +86-755-8427 6832

Email & Skype: info@chipsmall.com Web: www.chipsmall.com

Address: A1208, Overseas Decoration Building, #122 Zhenhua RD., Futian, Shenzhen, China



DUAL CHANNEL SINGLE CELL LINEAR LITHIUM BATTERY CHARGER WITH 28V OVP and PROGRAMMABLE CHARGE TIMER

Description

The APM8601 is a dual input channel linear Li-Ion charger for portable equipment that is optimized for small form-factor applications.

The charge algorithm in the APM8601 covers all the charge requirements for a single Li-Ion battery cell. Included is pre-charging for deeply discharged cells, constant current / constant voltage fast charging and a top-off feature to bring the cell safely to a full-charge level.

The battery is constantly monitored for overvoltage, charge time and cell temperature to ensure safe charging. A fault is triggered once the charge time exceeds a value that is programmable using a single capacitor and the temperature measurement is achieved through a thermistor positioned close to the battery cell.

The APM8601 automatically selects the USB or DC input, depending on which is valid (DC has priority if both are valid). The charging current from the USB input is set to 100mA or 500mA based on the logic level of the USEL input.

The APM8601 is packaged in U-DFN3030-14 package with a thermal pad.

Features

- Linear Lithium Ion / Lithium Polymer charging IC
- Supply Input Safe up to 28V
- Fast Charging with Maximum Current of 1A
- 100mA/500mA USB Charge Current Selected with USEL
- Resistor-Programmable Charging Current
- Resistor-Programmable End-Of-Charge
- Capacitor Programmable Charge Timer
- Three Charge Indicator Pins for a Status Display
- Thermal Protection
- DFN3030-14: Available in "Green" Molding Compound (No Br, Sb)
- **Lead-Free Finish; RoHS Compliant (Notes 1 & 2)**
- **Halogen and Antimony Free. "Green" Device (Note 3)**

Notes: 1. EU Directive 2002/95/EC (RoHS) & 2011/65/EU (RoHS 2) compliant. All applicable RoHS exemptions applied.
 2. See http://www.diodes.com/quality/lead_free.html for more information about Diodes Incorporated's definitions of Halogen- and Antimony-free, "Green" and Lead-free.
 3. Halogen- and Antimony-free "Green" products are defined as those which contain <900ppm bromine, <900ppm chlorine (<1500ppm total Br + Cl) and <1000ppm antimony compounds.

Pin Assignments

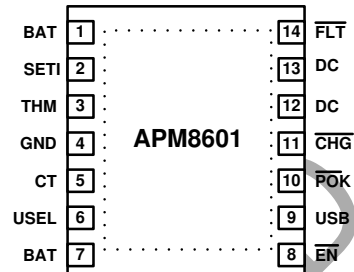

Figure 1 Pin Out

Applications

- Handheld Consumer Devices
- Cell Phones, PDAs, MP3 Players
- Handheld Test Equipment
- Digital Still Cameras
- Multimedia Players

Typical Application Circuit

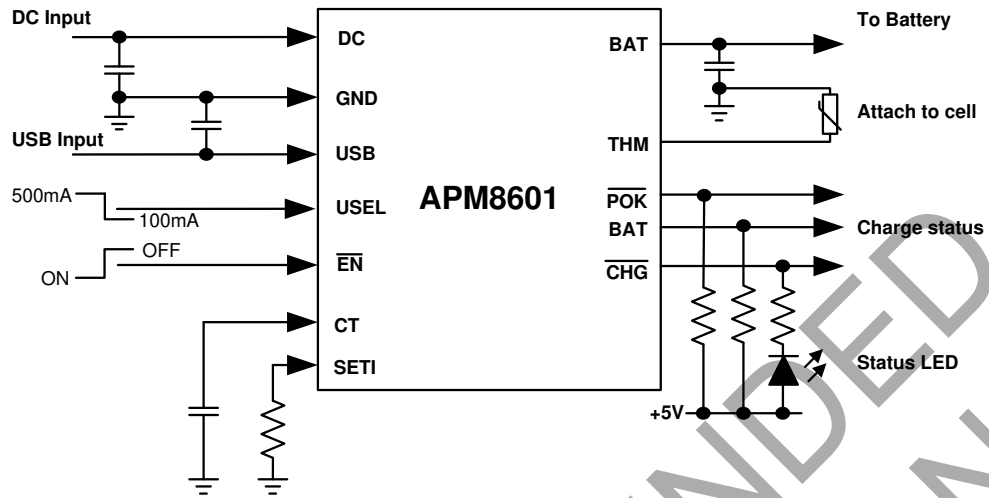
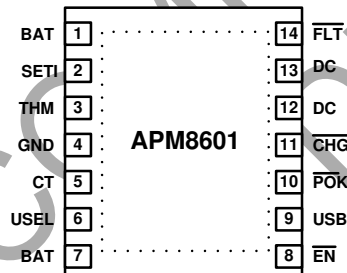

Figure 2. Typical Application Circuit

Pin Descriptions



Name	Pin #	Description	
BAT	1, 7	Connection to the Battery	The battery is charged via this pin and the BAT voltage is constantly monitored. Connect a bypass capacitor between BAT and GND (2.2μF).
SETI	2	Charge Current programming	The maximum charge current is programmed using a resistor from SETI to GND. This also determines the prequal current charging level and top-off threshold.
THM	3	Thermistor Input	To monitor the battery temperature, connect a 10kΩ NTC thermistor. Place this thermistor as close as possible to the battery. Connect THM to GND if temperature measurement is not required.
GND	4	Ground	Ground connection.
CT	5	Charge Timing	Connecting a capacitor from CT to GND will set the time-outs for prequal, top-off and fast-charge. Connecting CT direct to GND disables these timers.
USEL	6	USB Charge Select	Logic input to program the charge current in USB charging mode. $I_{BAT} = 90mA$ when USEL = low, and $I_{BAT} = 475mA$ when USEL = high.
\overline{EN}	8	Enable (Active-low)	The charger is enabled when this input is low. To start the charger connect \overline{EN} to GND. Drive this input high to disable the charger.
USB	9	USB Input	USB supply input. Connect a bypass capacitor (1μF) from USB to GND.
\overline{POK}	10	Power OK (Active-low)	When a valid input source is connected, this open-drain output is pulled low.
\overline{CHG}	11	Charge Status (Active-low)	Open-drain output that indicates the charging status. It is active only in the fast-charge state and goes high-impedance when the charger is either disabled or in prequal or top-off mode.
DC	12, 13	DC Input	DC supply input. The recommended input voltage is between 4.32V and 7V. This input is capable of withstanding up to 28V. Connect both DC pins together on the PCB. It is recommended to connect a bypass capacitor (1μF) from DC to GND.
\overline{FLT}	14	Fault Flag (Active-low)	If the prequal or fast-charge timers expire and the charging threshold voltage is not reached, \overline{FLT} (open-drain output) will go low. Remove the fault by cycling power or raise EN.
-	EP	Exposed Pad	For optimal thermal performance connect to copper on PCB (electrically this can be GND).

NOT RECOMMENDED FOR NEW DESIGN

Functional Block Diagram

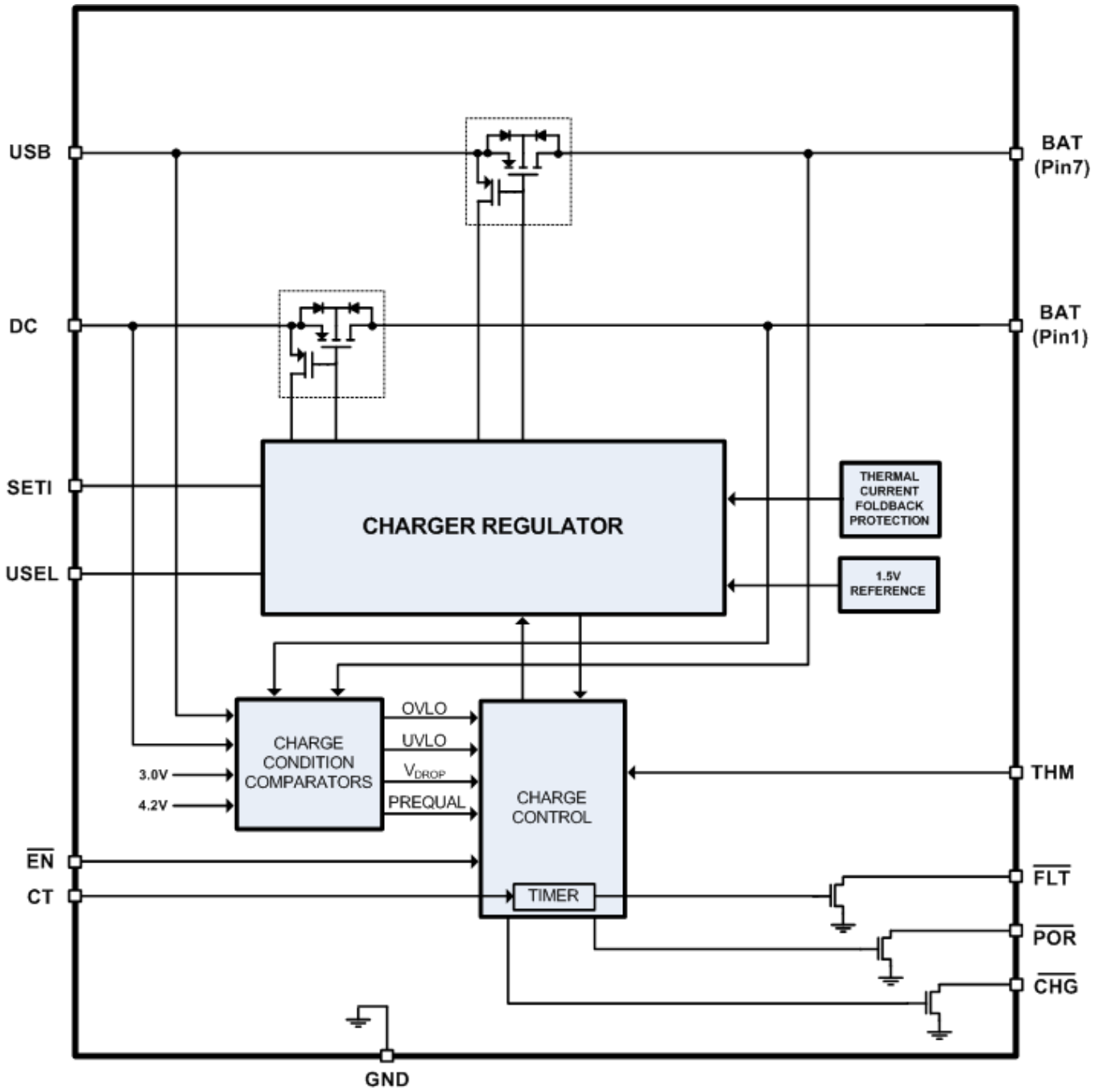

Absolute Maximum Ratings

Symbol	Parameter	Rating	Unit
–	DC, USB to GND	-0.3 to 28V	V
–	BAT, CT, SETI, USEL, THM, \overline{FLT} , \overline{CHG} , POK, EN to GND	-0.3 to 6V	V
ESD Susceptibility (Note 4)			
HBM	Human Body Model	2	kV
MM	Machine Model	200	V

Note: 4. Semiconductor devices are ESD sensitive and may be damaged by exposure to ESD events. Suitable ESD precautions should be taken when handling and transporting this device.

Thermal Resistance (Note 5)

Symbol	Parameter	Rating	Unit
θ_{JA}	Junction to Ambient	40	°C/W

Note: 5. Test condition for DFN3030-10: Device mounted on FR-4 2-layer board, 2oz copper, with minimum recommended pad on top layer and 6 vias to bottom layer 1.0"x1.5" ground plane.

Recommended Operating Conditions (Note 6)

Symbol	Parameter	Rating	Unit
–	Ambient Temperature Range	-40 to +85	°C
–	Input Supply Voltage	4.15 to 7.00	V
I_{CHARGE}	Typical Charge Current	0.1 to 1.0	A

Note: 6. The device function is not guaranteed outside of the recommended operating conditions.

NOT RECOMMENDED FOR NEW DESIGN

Electrical Characteristics

APM8601 is tested at $V_{DC} = V_{USB} = 5V$, $V_{BAT} = 4V$, $V_{\overline{EN}} = 0V$, $R_{SETI} = 2k\Omega$, $C_{CT} = 68nF$, at an ambient temperature of $+25^{\circ}C$ unless otherwise noted.

Symbol	Parameter	Test Conditions	Min	Typ.	Max	Unit
V_{DC}/V_{USB}	Input Voltage Range	–	0	–	28	V
V_{DC}/V_{USB}	Input Operating Range (Note 7)	–	4.15	–	7.00	V
UVLO	Input Undervoltage Lock Out (Note 7)	Input rising, 500mV hysteresis (typ.) $V_{BAT} = 3.2V$	3.85	4.0	4.15	V
OVLO	Input Overvoltage Lock Out	Input rising, 200mV hysteresis (typ.)	7.2	7.5	7.8	V
I_{DC}/I_{USB}	Input Supply Current	$I_{BAT} = 0mA$, $R_{THM} = 10k\Omega$	–	750	1200	μA
I_{SHTDWN}	Shutdown Current	$\overline{EN} = High$, $T_A = +25^{\circ}C$	–	275	435	μA
R_{DS_ON}	Input to BAT On-Resistance	Input = 3.7V, $V_{BAT} = 3.6V$	–	0.5	0.8	Ω
$V_{DROPOUT}$	Input to BAT dropout Voltage	Input falling, 200mV hysteresis (typ.)	5	55	150	mV
V_{BAT_REG}	Battery Voltage Regulation	$I_{BAT} = 0mA$, $T_A = +25^{\circ}C$	4.179	4.2	4.221	V
BAT_{RSTTH}	Battery Fast-Charge Restart Threshold	From BAT regulation voltage	-230	-175	-110	mV
I_{DC_CHG}	DC Charge Current $V_{USB} = 0V$	$R_{SETI} = 1.5k\Omega$	950	1000	1140	mA
		$R_{SETI} = 2.0k\Omega$	727	750	870	
		$R_{SETI} = 5.0k\Omega$	280	300	353	
		Prequal, $R_{SETI} = 2k\Omega$, $V_{BAT} = 2.5V$	60	75	95	
I_{USB_CHG}	USB Charge Current $V_{DC} = 0V$	$V_{USEL} = 5V$	450	475	500	mA
		$V_{USEL} = 0V$	75	90	105	
		Prequal, $R_{SETI} = 2k\Omega$, $V_{BAT} = 2.5V$	60	75	95	
SS	Soft-Start Time	Ramp time to fast-charge	–	1.2	–	ms
V_{PREQ_TH}	BAT Prequel Threshold	V_{BAT} rising, 180mV hysteresis (typ.)	2.9	3.0	3.1	V
I_{LEAK}	BAT Leakage Current	$V_{DC} = V_{USB} = 0V$, $V_{BAT} = 4.2V$	–	0.001	5	μA
R_{SETI}	Resistance Range for SETI	Guaranteed by charging current	1.5	–	5.0	k Ω

Note: 7. Guaranteed by testing of undervoltage- and overvoltage-threshold. To completely charge a battery cell, the input voltage must be greater than 4.32V.

Electrical Characteristics (Cont.)

APM8601 is tested at $V_{DC} = V_{USB} = 5V$, $V_{BAT} = 4V$, $V_{EN} = 0V$, $R_{SET1} = 2k\Omega$, $C_{CT} = 68nF$, at an ambient temperature of $+25^{\circ}C$ unless otherwise noted.

Symbol	Parameter	Test Conditions	Min	Typ.	Max	Unit
EN, USEL						
-	Logic Input Thresholds	Rising	-	-	1.6	V
		Falling	0.4	-	-	
-	Logic Input Leakage Current	$V_{EN} = V_{USEL} = 0$ to $5.5V$, $T_A = +25^{\circ}C$	-	0.001	1	μA
POK, CHG, FLT						
-	Logic Output Voltage, Low	$I_{POK} = I_{CHG} = I_{FLT} = 1mA$	-	12	100	mV
	Logic Output Leakage Current, High	$V_{POK} = V_{CHG} = V_{FLT} = 5.5V$ $V_{DC} = V_{USB} = 0V$ $T_A = +25^{\circ}C$	-	0.001	1	μA
I_{TOP_OFF}	\overline{CHG} / Top-Off Threshold	I_{BAT} falling, battery is charged	$R_{SET1} = 1.5k\Omega$ - 75 $R_{SET1} = 2.0k\Omega$ 37.5 56.25 75 $R_{SET1} = 5.0k\Omega$ - 22.5 -		mA	
R_{THM_PULLUP}	Internal Pullup Resistance	-	-	10	-	k Ω
R_{THM}	THM Resistance, Hot	R_{THM} falling, 420 Ω hyst. (typ.)	3.72	3.94	4.13	k Ω
	THM Resistance, Cold	R_{THM} rising, 2.7k Ω hyst. (typ.)	26.7	28.3	29.7	k Ω
	THM Resistance, Disabled	R_{THM} falling, 230 Ω hyst. (typ.)	260	315	370	Ω
CT_{ACCU}	Charge Timer Accuracy	$C_{CT} = 68nF$	-20	-	+20	%
$TL_{PREQUAL}$	Prequal Time Limit	From entering prequal to \overline{FLT} going low, $V_{BAT} < 3V$	34.8			min
TL_{CHG}	Charge Time Limit	From entering fast-charge to \overline{FLT} going low, $3V < V_{BAT} < 4.2V$	334			min
TL_{TOP_OFF}	Top-Off Time Limit	From \overline{CHG} going high to charger disabled	34.8			min
$THFB_{TEMP}$	Thermal Foldback Threshold Temperature	Junction temperature beyond which the charge current is reduced, T_J rising	+100			$^{\circ}C$
$THFB_{GAIN}$	Thermal Foldback Gain	Reduction of I_{BAT} for increase in T_J (using V_{DC}), $R_{SET1} = 1.5k\Omega$	5			%/ $^{\circ}C$

Functional Description

APM8601 is a linear Li-Ion battery charger device for single-cell applications. It has dual power inputs (DC and USB) and the charge currents can be programmed with the R_{SET1} resistor and/or the USEL pin. The device also incorporates several safety features, such as charge timers, battery temperature monitoring and internal thermal limiting.

Functional State Diagram

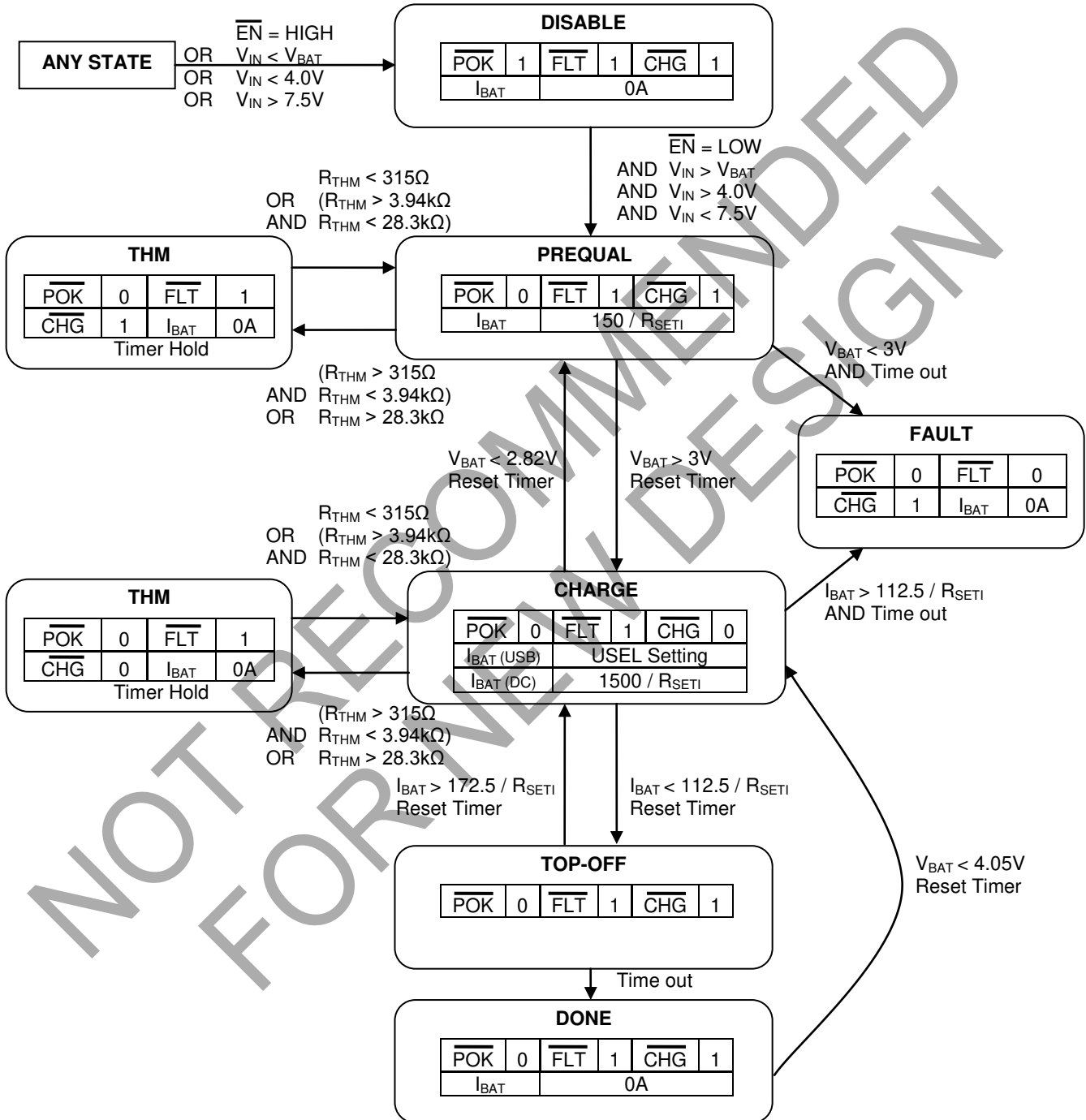

Functional Description (Cont.)

INPUTS

DC Pins 12 and 13 are the DC input. This input will allow charging from input voltages between 4.15V and 7V, and can withstand up to 28V without device damage although charging is disabled above 7.5V (typ.).

USB Pin 9 is the USB power input. This input will charge with input voltages from 4.15V to 7V. The charging current drawn from USB is selected using the USEL pin, either at 95mA (1 USB power allocation unit) or 475mA (5 USB power allocation units, High Power). Note that R_{SETI} has no effect on USB charging currents in the Charge state, but R_{SETI} does affect the Prequal current when charging from USB. This pin will also withstand up to 28V, but charging is disabled above 7.5V (typ.).

If both DC and USB are connected and valid, power will be drawn from DC with charge current set by R_{SETI}. USB and USEL will be ignored.

GND System ground connection.

EN Pin 8 is the enable pin of the device. When pulled low the device will operate normally. When high, the device will remain in the disabled state. For auto-starting, connect pin 8 directly to GND.

SETI Pin 2 allows the charge currents to be programmed.

$$R_{SETI} = \frac{1500}{I_{CHARGE}}$$

The charge current setting also changes the currents in prequal and top-off modes (being 10% and 7.5% of I_{CHARGE} respectively):

$$I_{PREQUAL} = \frac{150}{R_{SETI}} \quad I_{TOPOFF} = \frac{112.5}{R_{SETI}}$$

This pin can also be used to monitor the battery charging current:

$$I_{CHARGE} = \frac{V_{SETI} \times 1000}{R_{SETI}}$$

THM The thermistor connection is on pin 3. This allows the battery temperature to be monitored using a 10k NTC thermistor, which should be placed as close as possible to the battery cell. If no thermistor is used then this input should be connected directly to ground. The charger will operate when there is less than 315Ω on this input (i.e., no thermistor connected); will be disabled when there is between 315Ω and 3.94kΩ; enabled when between 3.94kΩ and 28.3kΩ; and disabled above 28.3kΩ.

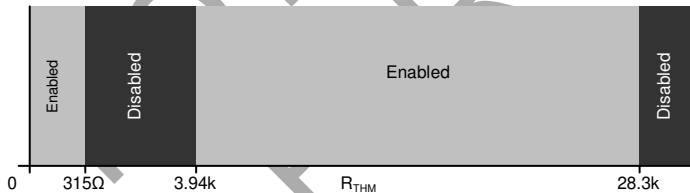

Thermistor	Resistance in kΩ at			Typical in °C	
	0°C	25°C	50°C	Hot trip	Cold Trip
Beta					
3000	25.1	10	4.6	55.1	-3.2
3250	27.1	10	4.3	52.6	-1.3
3500	29.3	10	4	50.5	0.5
3750	31.7	10	3.8	48.6	2.0

Functional Description (Cont.)

USEL Pin 6 allows the selection of the USB charging current. When low, I_{BAT} is limited to 95mA (one USB power allocation unit) and when High I_{BAT} is limited to 475mA (5 USB power allocation units, High Power), when drawing power from the USB input. This pin does not affect the device operation when power is being drawn from DC.

CT The Charge Timer input on pin 5 allows selection of how long the system timers for Prequal, Charge and Top-off states last. They are set by selecting the value of capacitor, C_{CT} :

$$T_{CHARGE} = 334 \text{ min} \times \left(\frac{C_{CT}}{68\text{nF}} \right)$$

$$T_{PREQUAL} = T_{TOPOFF} = 34.8 \text{ min} \times \left(\frac{C_{CT}}{68\text{nF}} \right)$$

The charge timer will hold its current value if the charging was stopped via the thermistor and continue when the battery is in a valid temperature range for charging.

OUTPUTS

BAT Pins 1 and 7 are the current-controlled charging outputs for the battery cell. They should be connected together and to the positive terminal of the battery. The chip monitors the voltage on these pins. There should be a 2.2 μ F capacitor connected from BAT to GND.

POK The $\overline{\text{POK}}$ flag on pin 10 is pulled low when a valid power input is available on either DC or USB inputs. It will go high when no valid power is available and the device will enter the Disable state.

CHG The $\overline{\text{CHG}}$ flag at pin 11 is pulled low when the device is in the Charge state. It will be high in Prequal and Top-off states. If the thermistor trips the circuit into the THM state (from Prequal or Charge states), $\overline{\text{CHG}}$ will hold its previous value.

FLT The $\overline{\text{FLT}}$ flag on pin 14 indicates a battery fault, as determined by a time-out in either the Prequal or Charge states. If the battery voltage does not reach 3V after the prequal timer (default 34.8mins), or does not reduce charging current to 7.5% after the charge timer (default 334mins), this indicates that the battery has failed or is failing and this will trigger the FLT flag. This flag will not automatically reset, and can only be cleared by cycling the power input or the EN pin.

NOT RECOMMENDED FOR NEW DESIGN

Functional Description (Cont.)

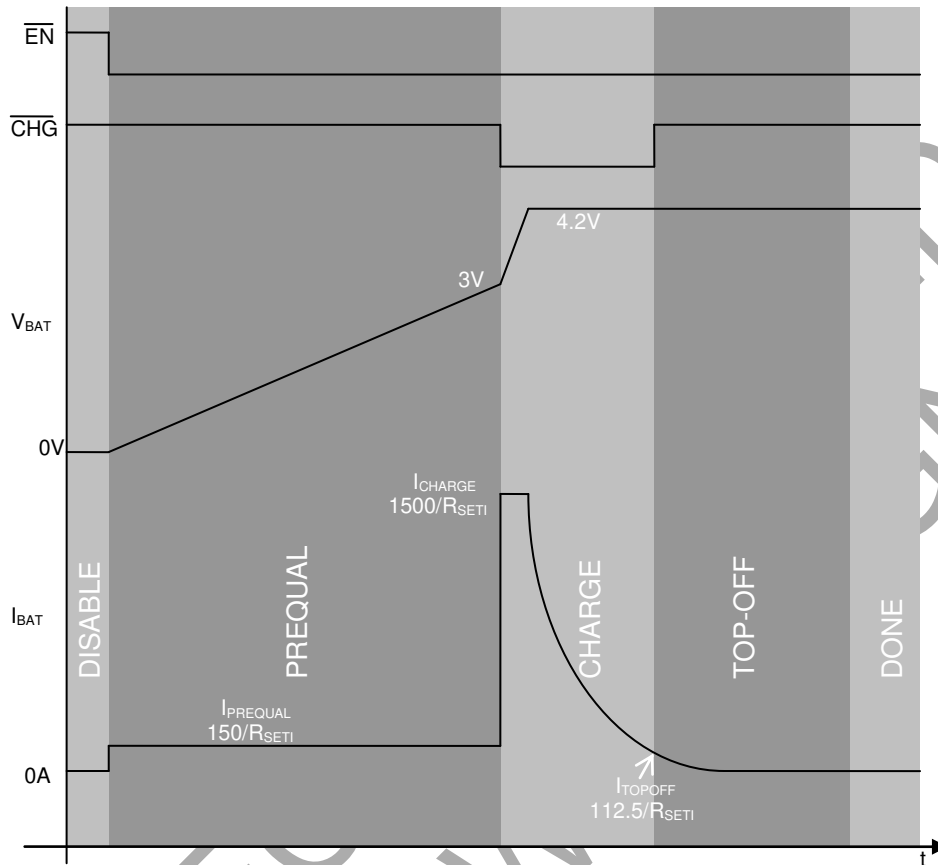

CHARGING PROCESS DESCRIPTION

The charging process is as follows, working through the state diagram.

The device will begin in the **Disable** state as the input power supply ramps from 0V. Once the input power supply has got into the valid range (4.15V – 7V), and the device is enabled then it will enter the **Prequal** state. This state allows for slow charging of a severely discharged battery. If the battery is already partially charged then the condition to move into the **Charge** state is met. If it is not then the slow charge will increase the battery voltage until it can enter the **Charge** state, or if the voltage does not rise sufficiently before the charge timer runs out (set using the capacitor on the CT pin) then the device will go into the **Fault** state, indicating that the battery cell may be damaged or has failed and is not taking charge. In the **Prequal** state the battery temperature can be monitored with a 10k NTC thermistor connected to the THM pin, and if the battery temperature goes out of range (above ~50°C or below ~0°C, depending on thermistor choice) then charging will be suspended with the device going into the **THM** state.

Once the battery has charged to a level of 3V, the device enters the **Charge** state, allowing faster charging of the battery in its normal voltage range, with 10 times the current used in the **Prequal** state. For information on setting the charge currents, see the functional description of the SET1 pin. Again, the battery temperature is monitored and charging will be suspended if the temperature goes out of range. The **Charge** state will last until the current drawn by the battery drops to 7.5% of the full charge current. The device will then enter the **Top-Off** state, maintaining battery voltage and providing top-off charging current for the time defined by the C_T value. Once that timer completes, the device will enter the **Done** state, with zero battery current. If the battery voltage falls below 4.05V then the device will automatically return to the **Charge** state.

Ordering Information

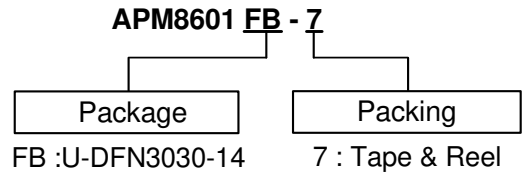

Device	Package Code	Packaging (Note 8)	7" Tape and Reel	
			Quantity	Part Number Suffix
APM8601FB-7	FB	U-DFN3030-14	3000/Tape & Reel	-7

Note: 8. Pad layout as shown on Diodes Inc. suggested pad layout document, which can be found on our website at <http://www.diodes.com/package-outlines.html>.

Marking Information

(Top View)

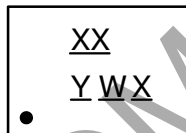

XX : P4 : APM8601
 Y : Year : 0~9
 W : Week : A~Z : 1~26 week;
 a~z : 27~52 week;
 z : represents 52 and 53
 X : A~Z : Internal Code

Part Number	Package	Identification Code
APM8601FB-7	U-DFN3030-14	P4

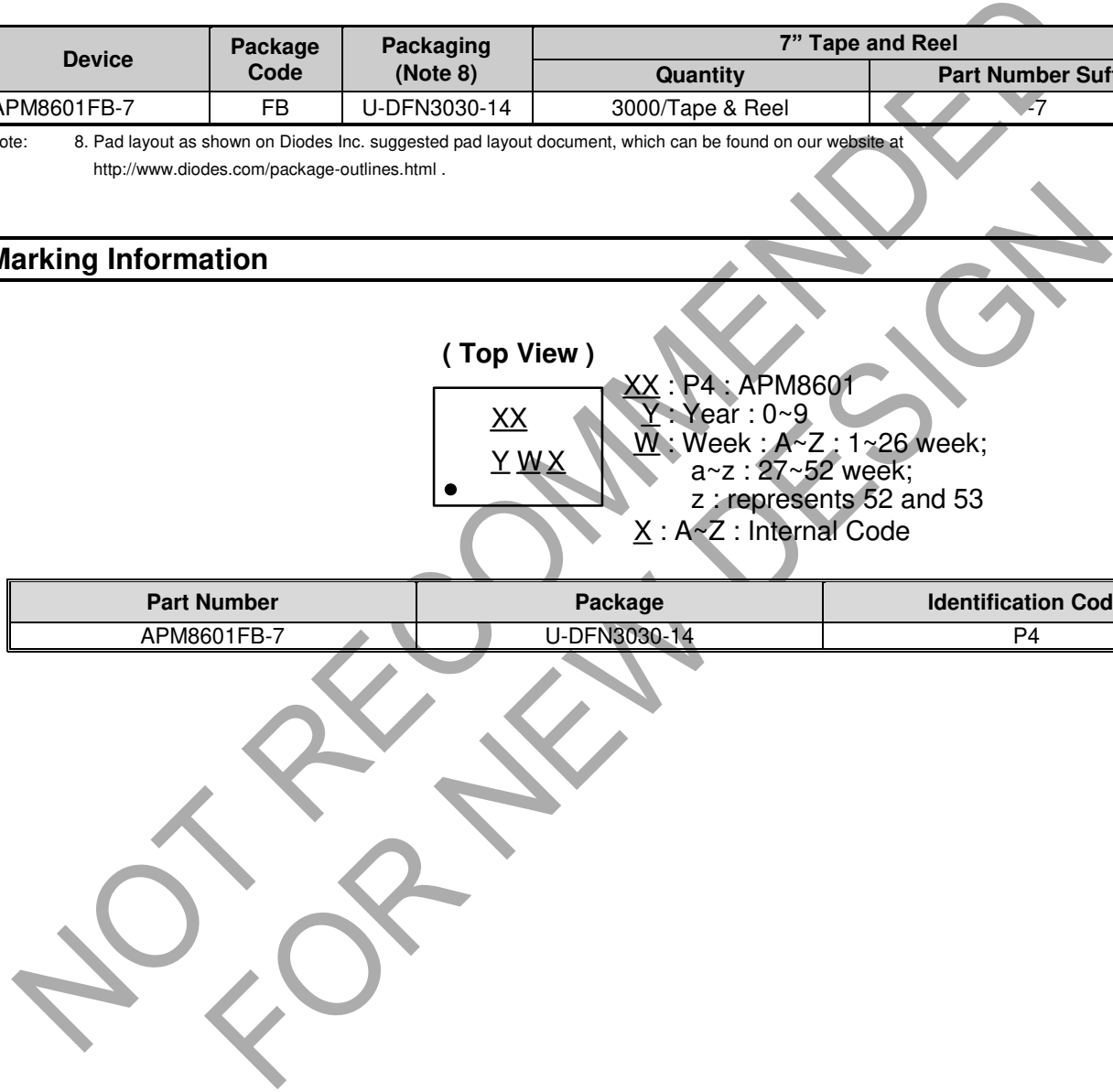

Package Outline Dimensions (All Dimensions in mm)

U-DFN3030-14

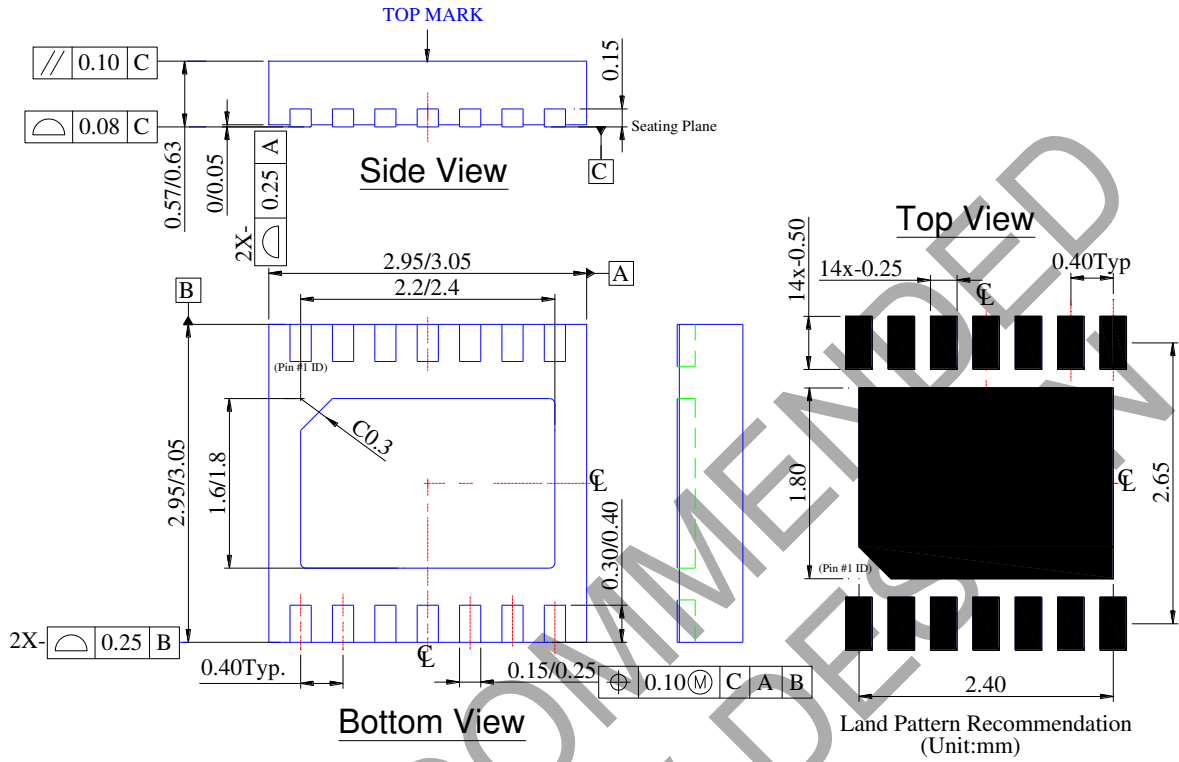

NOT RECOMMENDED FOR NEW DESIGN

Taping Orientation (Note 9)

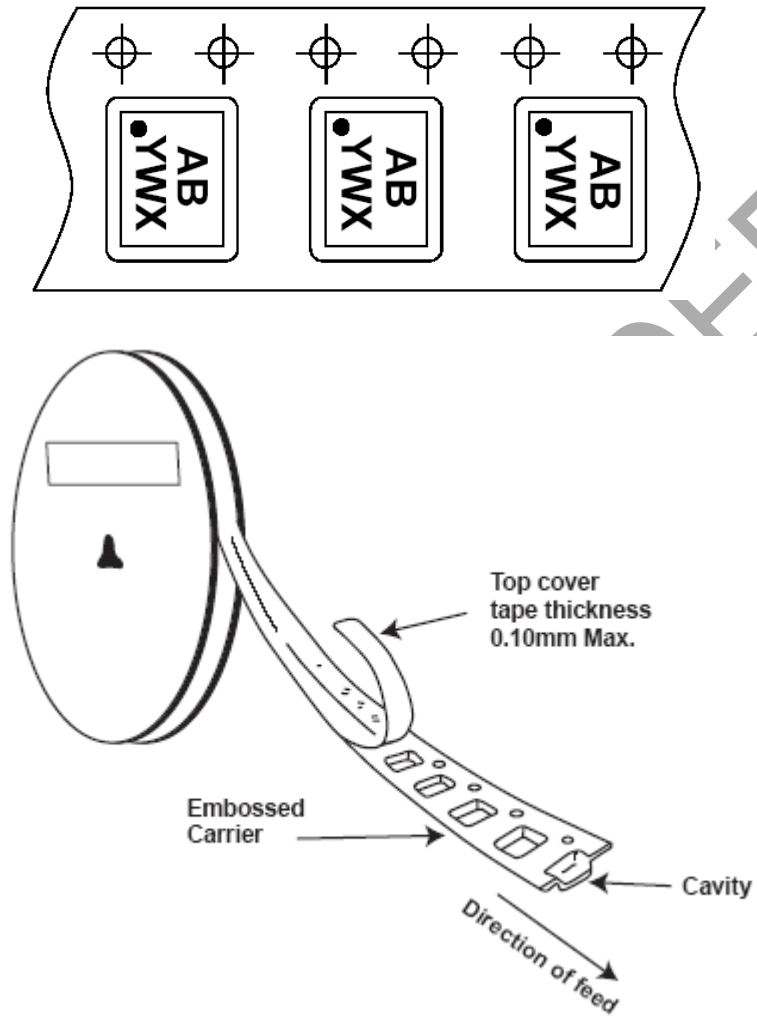

Note: 9. The taping orientation of the other package type can be found on our website at <http://www.diodes.com/datasheets/ap02007.pdf>

IMPORTANT NOTICE

DIODES INCORPORATED MAKES NO WARRANTY OF ANY KIND, EXPRESS OR IMPLIED, WITH REGARDS TO THIS DOCUMENT, INCLUDING, BUT NOT LIMITED TO, THE IMPLIED WARRANTIES OF MERCHANTABILITY AND FITNESS FOR A PARTICULAR PURPOSE (AND THEIR EQUIVALENTS UNDER THE LAWS OF ANY JURISDICTION).

Diodes Incorporated and its subsidiaries reserve the right to make modifications, enhancements, improvements, corrections or other changes without further notice to this document and any product described herein. Diodes Incorporated does not assume any liability arising out of the application or use of this document or any product described herein; neither does Diodes Incorporated convey any license under its patent or trademark rights, nor the rights of others. Any Customer or user of this document or products described herein in such applications shall assume all risks of such use and will agree to hold Diodes Incorporated and all the companies whose products are represented on Diodes Incorporated website, harmless against all damages.

Diodes Incorporated does not warrant or accept any liability whatsoever in respect of any products purchased through unauthorized sales channel. Should Customers purchase or use Diodes Incorporated products for any unintended or unauthorized application, Customers shall indemnify and hold Diodes Incorporated and its representatives harmless against all claims, damages, expenses, and attorney fees arising out of, directly or indirectly, any claim of personal injury or death associated with such unintended or unauthorized application.

Products described herein may be covered by one or more United States, international or foreign patents pending. Product names and markings noted herein may also be covered by one or more United States, international or foreign trademarks.

This document is written in English but may be translated into multiple languages for reference. Only the English version of this document is the final and determinative format released by Diodes Incorporated.

LIFE SUPPORT

Diodes Incorporated products are specifically not authorized for use as critical components in life support devices or systems without the express written approval of the Chief Executive Officer of Diodes Incorporated. As used herein:

A. Life support devices or systems are devices or systems which:

1. are intended to implant into the body, or
2. support or sustain life and whose failure to perform when properly used in accordance with instructions for use provided in the labeling can be reasonably expected to result in significant injury to the user.

B. A critical component is any component in a life support device or system whose failure to perform can be reasonably expected to cause the failure of the life support device or to affect its safety or effectiveness.

Customers represent that they have all necessary expertise in the safety and regulatory ramifications of their life support devices or systems, and acknowledge and agree that they are solely responsible for all legal, regulatory and safety-related requirements concerning their products and any use of Diodes Incorporated products in such safety-critical, life support devices or systems, notwithstanding any devices- or systems-related information or support that may be provided by Diodes Incorporated. Further, Customers must fully indemnify Diodes Incorporated and its representatives against any damages arising out of the use of Diodes Incorporated products in such safety-critical, life support devices or systems.

Copyright © 2016, Diodes Incorporated

www.diodes.com