



Chipsmall Limited consists of a professional team with an average of over 10 year of expertise in the distribution of electronic components. Based in Hongkong, we have already established firm and mutual-benefit business relationships with customers from,Europe,America and south Asia,supplying obsolete and hard-to-find components to meet their specific needs.

With the principle of “Quality Parts,Customers Priority,Honest Operation,and Considerate Service”,our business mainly focus on the distribution of electronic components. Line cards we deal with include Microchip,ALPS,ROHM,Xilinx,Pulse,ON,Everlight and Freescale. Main products comprise IC,Modules,Potentiometer,IC Socket,Relay,Connector.Our parts cover such applications as commercial,industrial, and automotives areas.

We are looking forward to setting up business relationship with you and hope to provide you with the best service and solution. Let us make a better world for our industry!



## Contact us

Tel: +86-755-8981 8866 Fax: +86-755-8427 6832

Email & Skype: info@chipsmall.com Web: www.chipsmall.com

Address: A1208, Overseas Decoration Building, #122 Zhenhua RD., Futian, Shenzhen, China





**MICROCHIP**

---

**MCP16251**  
**One-Cell Boost Converter**  
**with External UVLO Circuit**  
**Reference Design**

---

**Note the following details of the code protection feature on Microchip devices:**

- Microchip products meet the specification contained in their particular Microchip Data Sheet.
- Microchip believes that its family of products is one of the most secure families of its kind on the market today, when used in the intended manner and under normal conditions.
- There are dishonest and possibly illegal methods used to breach the code protection feature. All of these methods, to our knowledge, require using the Microchip products in a manner outside the operating specifications contained in Microchip's Data Sheets. Most likely, the person doing so is engaged in theft of intellectual property.
- Microchip is willing to work with the customer who is concerned about the integrity of their code.
- Neither Microchip nor any other semiconductor manufacturer can guarantee the security of their code. Code protection does not mean that we are guaranteeing the product as "unbreakable."

Code protection is constantly evolving. We at Microchip are committed to continuously improving the code protection features of our products. Attempts to break Microchip's code protection feature may be a violation of the Digital Millennium Copyright Act. If such acts allow unauthorized access to your software or other copyrighted work, you may have a right to sue for relief under that Act.

---

Information contained in this publication regarding device applications and the like is provided only for your convenience and may be superseded by updates. It is your responsibility to ensure that your application meets with your specifications. MICROCHIP MAKES NO REPRESENTATIONS OR WARRANTIES OF ANY KIND WHETHER EXPRESS OR IMPLIED, WRITTEN OR ORAL, STATUTORY OR OTHERWISE, RELATED TO THE INFORMATION, INCLUDING BUT NOT LIMITED TO ITS CONDITION, QUALITY, PERFORMANCE, MERCHANTABILITY OR FITNESS FOR PURPOSE. Microchip disclaims all liability arising from this information and its use. Use of Microchip devices in life support and/or safety applications is entirely at the buyer's risk, and the buyer agrees to defend, indemnify and hold harmless Microchip from any and all damages, claims, suits, or expenses resulting from such use. No licenses are conveyed, implicitly or otherwise, under any Microchip intellectual property rights unless otherwise stated.

*Microchip received ISO/TS-16949:2009 certification for its worldwide headquarters, design and wafer fabrication facilities in Chandler and Tempe, Arizona; Gresham, Oregon and design centers in California and India. The Company's quality system processes and procedures are for its PIC<sup>®</sup> MCUs and dsPIC<sup>®</sup> DSCs, KEELOQ<sup>®</sup> code hopping devices, Serial EEPROMs, microperipherals, nonvolatile memory and analog products. In addition, Microchip's quality system for the design and manufacture of development systems is ISO 9001:2000 certified.*

**QUALITY MANAGEMENT SYSTEM  
CERTIFIED BY DNV  
= ISO/TS 16949 =**

**Trademarks**

The Microchip name and logo, the Microchip logo, AnyRate, AVR, AVR logo, AVR Freaks, BeaconThings, BitCloud, CryptoMemory, CryptoRF, dsPIC, FlashFlex, flexPWR, Helder, JukeBlox, KEELOQ, KEELOQ logo, Klear, LANCheck, LINK MD, maXStylus, maXTouch, MediaLB, megaAVR, MOST, MOST logo, MPLAB, OptoLyzr, PIC, picoPower, PICSTART, PIC32 logo, Prochip Designer, QTouch, RightTouch, SAM-BA, SpyNIC, SST, SST Logo, SuperFlash, tinyAVR, UNI/O, and XMEGA are registered trademarks of Microchip Technology Incorporated in the U.S.A. and other countries.

ClockWorks, The Embedded Control Solutions Company, EtherSynch, Hyper Speed Control, HyperLight Load, IntelliMOS, mTouch, Precision Edge, and Quiet-Wire are registered trademarks of Microchip Technology Incorporated in the U.S.A.

Adjacent Key Suppression, AKS, Analog-for-the-Digital Age, Any Capacitor, AnyIn, AnyOut, BodyCom, chipKIT, chipKIT logo, CodeGuard, CryptoAuthentication, CryptoCompanion, CryptoController, dsPICDEM, dsPICDEM.net, Dynamic Average Matching, DAM, ECAN, EtherGREEN, In-Circuit Serial Programming, ICSP, Inter-Chip Connectivity, JitterBlocker, KlearNet, KlearNet logo, Mindi, MiWi, motorBench, MPASM, MPF, MPLAB Certified logo, MPLIB, MPLINK, MultiTRAK, NetDetach, Omniscient Code Generation, PICDEM, PICDEM.net, PICkit, PICtail, PureSilicon, QMatrix, RightTouch logo, REAL ICE, Ripple Blocker, SAM-ICE, Serial Quad I/O, SMART-I.S., SQI, SuperSwitcher, SuperSwitcher II, Total Endurance, TSHARC, USBCheck, VariSense, ViewSpan, WiperLock, Wireless DNA, and ZENA are trademarks of Microchip Technology Incorporated in the U.S.A. and other countries.

SQTP is a service mark of Microchip Technology Incorporated in the U.S.A.

Silicon Storage Technology is a registered trademark of Microchip Technology Inc. in other countries.

GestIC is a registered trademark of Microchip Technology Germany II GmbH & Co. KG, a subsidiary of Microchip Technology Inc., in other countries.

All other trademarks mentioned herein are property of their respective companies.

© 2017, Microchip Technology Incorporated, All Rights Reserved.

ISBN: 978-1-5224-1313-4



# MCP16251 ONE-CELL BOOST CONVERTER WITH EXTERNAL UVLO CIRCUIT

## Table of Contents

<b>Preface</b> .....	<b>7</b>
Introduction.....	7
Document Layout .....	7
Conventions Used in this Guide .....	8
Recommended Reading.....	9
The Microchip Web Site .....	9
Customer Support .....	9
Document Revision History .....	9
<b>Chapter 1. Product Overview</b>	
1.1 Introduction.....	11
1.2 MCP16251 Device Short Overview.....	11
1.2.1 MCP16251 Device Features .....	12
1.3 What is the MCP16251 One-Cell Boost Converter with External UVLO Circuit? .....	13
1.4 What Does the MCP16251 One-Cell Boost Converter with External UVLO Circuit Kit Contain?.....	13
<b>Chapter 2. Installation and Operation</b>	
2.1 Introduction15	
2.1.1 MCP16251 One-Cell Boost Converter with External UVLO Circuit Features15	
2.1.2 Short Battery Considerations Overview.....	16
2.2 Getting Started .....	17
2.2.1 Power Input and Output Connection .....	17
2.2.2 MCP16251 One-Cell Boost Converter with External UVLO Circuit Operation.....	18
<b>Appendix A. Schematic and Layouts</b>	
A.1 Introduction .....	21
A.2 Board – Schematic.....	22
A.3 Board – Top Silk and Pads .....	23
A.4 Board – Top Copper .....	23
A.5 Board – Bottom Silk and Pads .....	24
A.6 Board – Bottom Copper .....	24
A.7 Board – Top 3D View.....	25
A.8 Board – Bottom 3D View.....	25
<b>Appendix B. Bill Of Materials (BOM)</b> .....	<b>27</b>
<b>Worldwide Sales and Service</b> .....	<b>28</b>

# MCP16251 One-Cell Boost Converter with External UVLO Circuit

---

---

NOTES:

---

---

**Object of Declaration:**  
**MCP16251 Single Cell Boost Converter With External UVLO Reference Design**

EU Declaration of Conformity

This declaration of conformity is issued by the manufacturer.

The development/evaluation tool is designed to be used for research and development in a laboratory environment. This development/evaluation tool is not a Finished Appliance, nor is it intended for incorporation into Finished Appliances that are made commercially available as single functional units to end users under EU EMC Directive 2004/108/EC and as supported by the European Commission's Guide for the EMC Directive 2004/108/EC (8th February 2010).

This development/evaluation tool complies with EU RoHS2 Directive 2011/65/EU.

This development/evaluation tool, when incorporating wireless and radio-telecom functionality, is in compliance with the essential requirement and other relevant provisions of the R&TTE Directive 1999/5/EC and the FCC rules as stated in the declaration of conformity provided in the module datasheet and the module product page available at [www.microchip.com](http://www.microchip.com). For information regarding the exclusive, limited warranties applicable to Microchip products, please see Microchip's standard terms and conditions of sale, which are printed on our sales documentation and available at [www.microchip.com](http://www.microchip.com).

Signed for and on behalf of Microchip Technology Inc. at Chandler, Arizona, USA.

  
Derek Carlson

VP Development Tools

11-NOV-16  
Date

# MCP16251 One-Cell Boost Converter with External UVLO Circuit

---

---

NOTES:





# MCP16251 ONE-CELL BOOST CONVERTER WITH EXTERNAL UVLO CIRCUIT

## Preface

### NOTICE TO CUSTOMERS

All documentation becomes dated, and this manual is no exception. Microchip tools and documentation are constantly evolving to meet customer needs, so some actual dialogs and/or tool descriptions may differ from those in this document. Please refer to our website ([www.microchip.com](http://www.microchip.com)) to obtain the latest documentation available.

Documents are identified with a “DS” number. This number is located on the bottom of each page, in front of the page number. The numbering convention for the DS number is “DSXXXXXXXXA”, where “XXXXXXXX” is the document number and “A” is the revision level of the document.

For the most up-to-date information on development tools, see the MPLAB® IDE online help. Select the Help menu, and then Topics to open a list of available online help files.

## INTRODUCTION

This chapter contains general information that will be useful to know before using the MCP16251 One-Cell Boost Converter with External UVLO Circuit. Items discussed in this chapter include:

- [Document Layout](#)
- [Conventions Used in this Guide](#)
- [Recommended Reading](#)
- [The Microchip Web Site](#)
- [Customer Support](#)
- [Document Revision History](#)

## DOCUMENT LAYOUT

This document describes how to use the MCP16251 One-Cell Boost Converter with External UVLO Circuit as an evaluation tool to test the external undervoltage lockout circuit. The manual layout is as follows:

- **Chapter 1. “Product Overview”** – Important information about the MCP16251 One-Cell Boost Converter with External UVLO Circuit.
- **Chapter 2. “Installation and Operation”** – Includes instructions on how to get started with the MCP16251 One-Cell Boost Converter with External UVLO Circuit.
- **Appendix A. “Schematic and Layouts”** – Shows the schematic and layout diagrams for the MCP16251 One-Cell Boost Converter with External UVLO Circuit.
- **Appendix B. “Bill Of Materials (BOM)”** – Lists the parts used to build the MCP16251 One-Cell Boost Converter with External UVLO Circuit.



# MCP16251 One-Cell Boost Converter with External UVLO Circuit

## CONVENTIONS USED IN THIS GUIDE

This manual uses the following documentation conventions:

### DOCUMENTATION CONVENTIONS

Description	Represents	Examples
<b>Arial font:</b>		
Italic characters	Referenced books	<i>MPLAB<sup>®</sup> IDE User's Guide</i>
	Emphasized text	...is the <i>only</i> compiler...
Initial caps	A window	the Output window
	A dialog	the Settings dialog
	A menu selection	select Enable Programmer
Quotes	A field name in a window or dialog	"Save project before build"
Underlined, italic text with right angle bracket	A menu path	<u><i>File&gt;Save</i></u>
Bold characters	A dialog button	Click <b>OK</b>
	A tab	Click the <b>Power</b> tab
N'Rnnnn	A number in verilog format, where N is the total number of digits, R is the radix and n is a digit.	4'b0010, 2'hF1
Text in angle brackets < >	A key on the keyboard	Press <Enter>, <F1>
<b>Courier New font:</b>		
Plain Courier New	Sample source code	#define START
	Filenames	autoexec.bat
	File paths	c:\mcc18\h
	Keywords	_asm, _endasm, static
	Command-line options	-Opa+, -Opa-
	Bit values	0, 1
	Constants	0xFF, 'A'
Italic Courier New	A variable argument	<i>file.o</i> , where <i>file</i> can be any valid filename
Square brackets [ ]	Optional arguments	mcc18 [options] <i>file</i> [options]
Curly brackets and pipe character: {   }	Choice of mutually exclusive arguments; an OR selection	errorlevel {0 1}
Ellipses...	Replaces repeated text	var_name [, var_name...]
	Represents code supplied by user	void main (void) { ... }

## RECOMMENDED READING

This reference design describes how to use the MCP16251 One-Cell Boost Converter with External UVLO Circuit. Another useful document is listed below. The following Microchip document is available and recommended as a supplemental reference resource.

- **MCP16251/2 Data Sheet – “Low Quiescent Current, PFM/PWM Synchronous Boost Regulator with True Output Disconnect or Input/Output Bypass Option” (DS20005173)**

## THE MICROCHIP WEB SITE

Microchip provides online support via our web site at [www.microchip.com](http://www.microchip.com). This web site is used as a means to make files and information easily available to customers. Accessible by using your favorite Internet browser, the web site contains the following information:

- **Product Support** – Data sheets and errata, application notes and sample programs, design resources, user’s guides and hardware support documents, latest software releases and archived software
- **General Technical Support** – Frequently Asked Questions (FAQs), technical support requests, online discussion groups, Microchip consultant program member listing
- **Business of Microchip** – Product selector and ordering guides, latest Microchip press releases, listing of seminars and events, listings of Microchip sales offices, distributors and factory representatives

## CUSTOMER SUPPORT

Users of Microchip products can receive assistance through several channels:

- Distributor or Representative
- Local Sales Office
- Field Application Engineer (FAE)
- Technical Support

Customers should contact their distributor, representative or field application engineer (FAE) for support. Local sales offices are also available to help customers. A listing of sales offices and locations is included in the back of this document.

Technical support is available through the web site at:  
<http://www.microchip.com/support>

## DOCUMENT REVISION HISTORY

### Revision A (January 2017)

- Initial Release of this Document.

# MCP16251 One-Cell Boost Converter with External UVLO Circuit

---

---

NOTES:



# MCP16251 ONE-CELL BOOST CONVERTER WITH EXTERNAL UVLO CIRCUIT

## Chapter 1. Product Overview

### 1.1 INTRODUCTION

This chapter provides an overview of the MCP16251 One-Cell Boost Converter with External UVLO Circuit and covers the following topics:

- [MCP16251 Device Short Overview](#)
- [MCP16251 Device Features](#)
- [What is the MCP16251 One-Cell Boost Converter with External UVLO Circuit?](#)
- [What Does the MCP16251 One-Cell Boost Converter with External UVLO Circuit Kit Contain?](#)

### 1.2 MCP16251 DEVICE SHORT OVERVIEW

Microchip's MCP16251 device is a compact, high-efficiency, fixed-frequency, synchronous step-up DC-DC Converter. The very low quiescent current makes it ideal for battery-powered applications. Furthermore, the device provides a true output disconnect feature while in shutdown (EN = GND). The MCP16251 device consumes less than 0.6  $\mu$ A from the battery when in the shutdown state.

The MCP16251 automatically selects the best operating mode for efficiency: Pulse-Width Modulation (PWM) or Pulse-Frequency Modulation (PFM). The device has a very low (4  $\mu$ A) quiescent current (not switching, measured at output), a wide input voltage range (0.35 to 5.5V) and a low start-up voltage (0.82V) at a 1 mA load current.

**TABLE 1-1: THE MICROCHIP FAMILY OF BOOST DEVICES**

Parameter	MCP1623/4	MCP16251/2	MCP1640/B/C/D	MCP1642B/D
Mode	PWM Only or PWM/PFM	PWM/PFM	PWM Only or PWM/PFM	PWM Only
Start-up Voltage	0.65V	0.82V	0.65V	0.65V
Input Voltage	0.35V-5.5V	0.35V-5.5V	0.35V-5.5V	0.35V-5.5V
Peak Switch Current	425 mA	650 mA	850 mA	1.8A
Quiescent Current	19 $\mu$ A	4 $\mu$ A	19 $\mu$ A	500 $\mu$ A
V <sub>OUT</sub> Accuracy	$\pm$ 7.4%	$\pm$ 3%	$\pm$ 3%	$\pm$ 3%
Switching Frequency	370-630 kHz	500 kHz	500 kHz	1 MHz
Shutdown	True Load Disconnect	Input to Output Bypass or True Load Disconnect	Input to Output Bypass or True Load Disconnect	Input to Output Bypass or True Load Disconnect
Packages	6-Lead SOT-23	6-Lead SOT-23	6-Lead SOT-23	8-Lead MSOP
	8-Lead 2 x 3 DFN	8-Lead 2 x 3 DFN	8-Lead 2 x 3 DFN	8-Lead 2 x 3 DFN
Key Attributes	Lowest Cost	Lowest Quiescent Current, Energy Saving	Highest Performance	Highest Output Current

# MCP16251 One-Cell Boost Converter with External UVLO Circuit

The MCP16251 device is available in 6-Lead SOT-23 and 8-Lead 2 x 3 mm TDFN packages. For additional information on the MCP16251 device, refer to the “MCP16251/2 Data Sheet” (DS20005173).

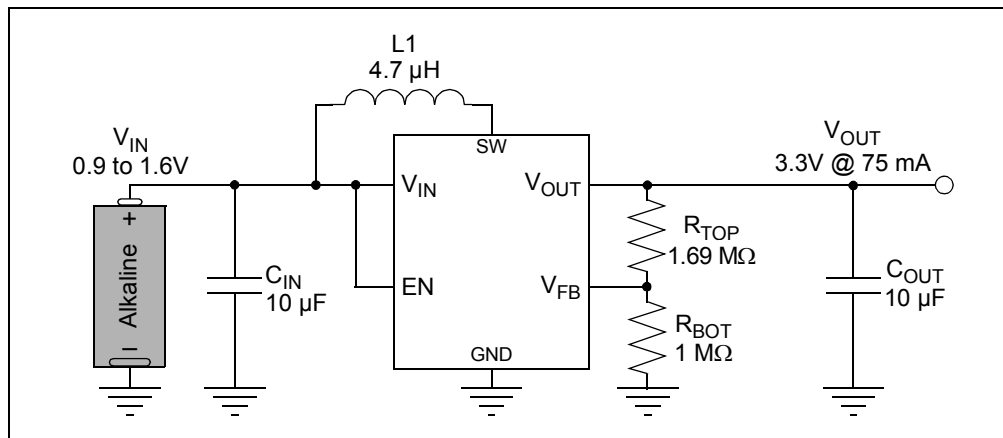

**FIGURE 1-1:** MCP16251/2 Typical Application Schematic.

## 1.2.1 MCP16251 Device Features

The MCP16251 device was developed to optimize battery life by having a very low quiescent current, typically 4  $\mu\text{A}$ , and a small, no load input current, typically 14  $\mu\text{A}$ . The MCP16251 is capable of regulating the output voltage over a wide range (1.8V to 5.5V) and typically delivers over a 100 mA load current at a 3.3V output when supplied from a single 1.5V cell.

The key features of the MCP16251 device that help optimize the battery life include:

- Up to 96% Typical Efficiency
- 4  $\mu\text{A}$  Quiescent Current
- PFM Switching mode for Light Loads, High Efficiency and Extended Battery Run Time
- Low Input Start-up Voltage, Typically 0.82V at a 1 mA Load Current
- Low Shutdown Voltage (continuously operating down to 0.35V input under light loads)
- True Output Disconnect Shutdown Option
- 14  $\mu\text{A}$  Typical No Load Input Current

For applications powered by alkaline cells that consume few milliamperes, the MCP16251 device can operate to the minimum input voltage necessary to completely drain the battery.

In general, OEMs recommend that the battery should not be discharged below its specified cut-off voltage; for an alkaline cell, this is 0.8-0.9V. Discharging a battery below this point increases the risk of battery leakage and rupture. For single cell applications, the battery can be discharged down to 0.5V if its voltage is strictly monitored. Because the MCP16251 can operate from an input voltage as low as 0.35V once it has started, for applications powered from alkaline batteries, an Undervoltage Lockout (UVLO) circuit is recommended. It also applies to rechargeable batteries, such as NiCd or NiMH (deep discharging will permanently damage the NiMH cell, increasing its internal resistance). Battery monitoring and UVLO circuits ensure that the battery is not discharged below the cut-off voltage once the converter has a good start-up.

### **1.3 WHAT IS THE MCP16251 ONE-CELL BOOST CONVERTER WITH EXTERNAL UVLO CIRCUIT?**

The MCP16251 One-Cell Boost Converter with External UVLO Circuit is a simple, low quiescent current, one-cell Boost Converter with an external UVLO circuit. The converter will not (re)start if the battery voltage is lower than 1.1V and will stop working if the battery voltage drops below 0.8V. The external ULVO circuit drains approximately 0.5  $\mu$ A from a discharged battery and approximately 2  $\mu$ A from a fresh battery.

### **1.4 WHAT DOES THE MCP16251 ONE-CELL BOOST CONVERTER WITH EXTERNAL UVLO CIRCUIT KIT CONTAIN?**

This MCP16251 One-Cell Boost Converter with External UVLO Circuit Kit includes:

- MCP16251 One-Cell Boost Converter with External UVLO Circuit (ARD00797)
- Important Information Sheet

# MCP16251 One-Cell Boost Converter with External UVLO Circuit

---

NOTES:



## Chapter 2. Installation and Operation

### 2.1 INTRODUCTION

#### 2.1.1 MCP16251 One-Cell Boost Converter with External UVLO Circuit Features

The MCP16251 One-Cell Boost Converter with External UVLO Circuit is developed to provide a solution for applications that require fixed start-up/shutdown thresholds. The board features a discrete UVLO circuit implemented with bipolar junction transistors (see [Figure 2-1](#)).

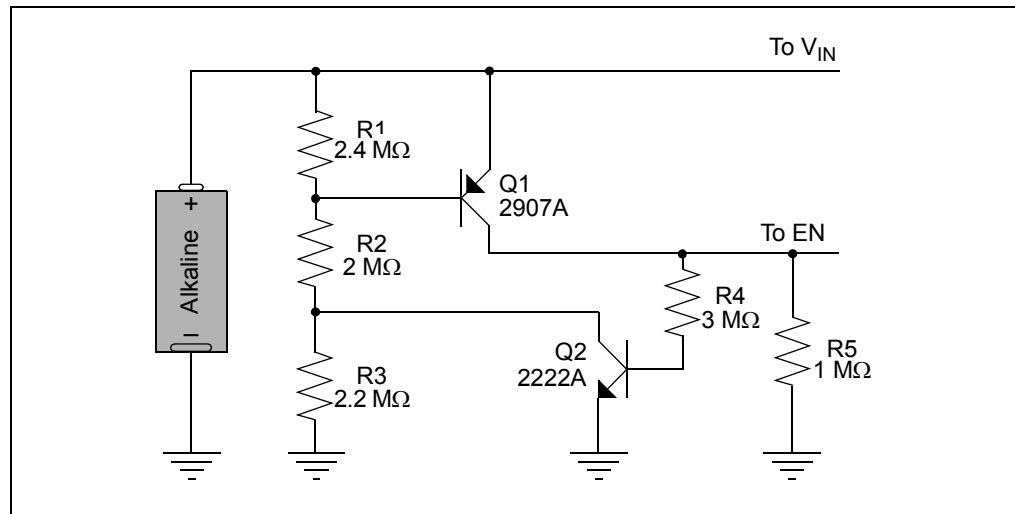

**FIGURE 2-1:** UVLO Circuit.

The MCP16251 One-Cell Boost Converter with External UVLO Circuit has the following features:

- Input Voltage: One AA Primary or Rechargeable Battery
- Output Voltage: 3.3V
- Output Current: <125 mA
- Start-up Voltage: 1.1V
- Automatic PFM/PWM Operation
- PWM Switching Frequency: 500 kHz
- Shutdown Voltage: 0.8V

## 2.1.2 Short Battery Considerations Overview

Although the marking on an alkaline battery will show 1.5V, the Open-Circuit Voltage (OCV) can be as high as 1.7V. The Closed Circuit Voltage (CCV), or operating voltage, will always be smaller than the OCV because of non-idealities in the cell (i.e., the internal resistance). Both the OCV and CCV vary with battery chemistry, State-of-Charge (SOC) and discharge rate.

The difference between the OCV and CCV is a function of current flow and internal resistance. When the load is removed, the battery voltage starts recovering slowly. At this state, the OCV can reach the nominal value, but a nearly depleted battery will not be capable of maintaining this voltage once the load is applied.

The internal resistance of a battery is not constant over its life span or charging/discharging cycles. As a battery discharges, its internal resistance gets higher, limiting the power that can be supplied to the load. The internal resistance also varies with battery chemistry, drain rate, battery age and temperature.

Discharging the battery below the OEM recommended cut-off voltage will increase the cell's internal resistance. For an alkaline cell, this is 0.8-0.9V. For applications that are battery-powered, an Undervoltage Lockout (UVLO) solution is recommended, because after a good start-up, as shown in [Table 1-1](#), Microchip's single cell Boost Converters can operate from an input voltage as low as 0.35V.

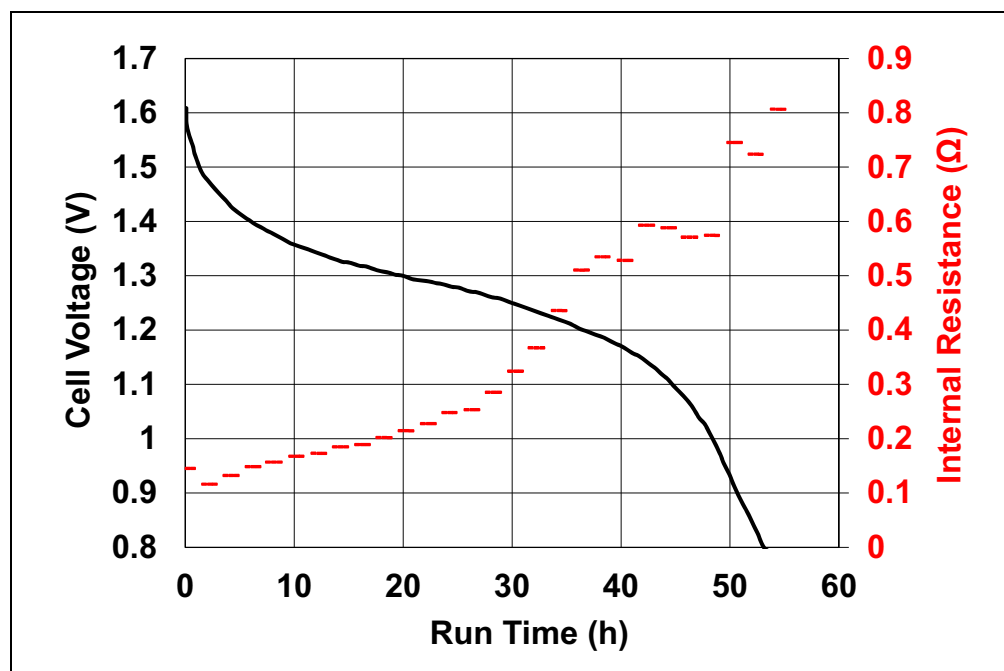

**FIGURE 2-2:** Typical Discharge Profile for an AA Alkaline Cell – Battery Voltage and Internal Resistance.

## 2.2 GETTING STARTED

The MCP16251 One-Cell Boost Converter with External UVLO Circuit is fully assembled and tested to evaluate the external UVLO circuit using the MCP16251/2 devices.

### 2.2.1 Power Input and Output Connection

#### 2.2.1.1 POWERING THE MCP16251 ONE-CELL BOOST CONVERTER WITH EXTERNAL UVLO CIRCUIT

The MCP16251 One-Cell Boost Converter with External UVLO Circuit can be powered either from the AA battery holder or from an external power supply connected between the  $V_{IN}$  and GND test pads. By default, the  $V_{IN}$  is connected to the input pin of the MCP16251 and disconnected from the battery's positive terminal. If a battery is used, jumper J1 must be closed.

When the Boost Converter is powered by an AA one-cell alkaline battery, the maximum output current is 125 mA.

**CAUTION**

Care must be taken when powering the board from an external supply; make sure jumper J1 is open if there is also a battery in the AA battery holder. Also, the minimum input voltage for which the MCP16251 Boost Converter will start switching is 1.1V and the maximum input voltage must not exceed 3.3V ( $V_{IN} < V_{OUT}$ ). If the input voltage drops below 0.8V, the Boost Converter will stop switching. To commute between normal operation and Sleep mode, switch SW1 can be turned on or off.

#### 2.2.1.2 BOARD TESTING

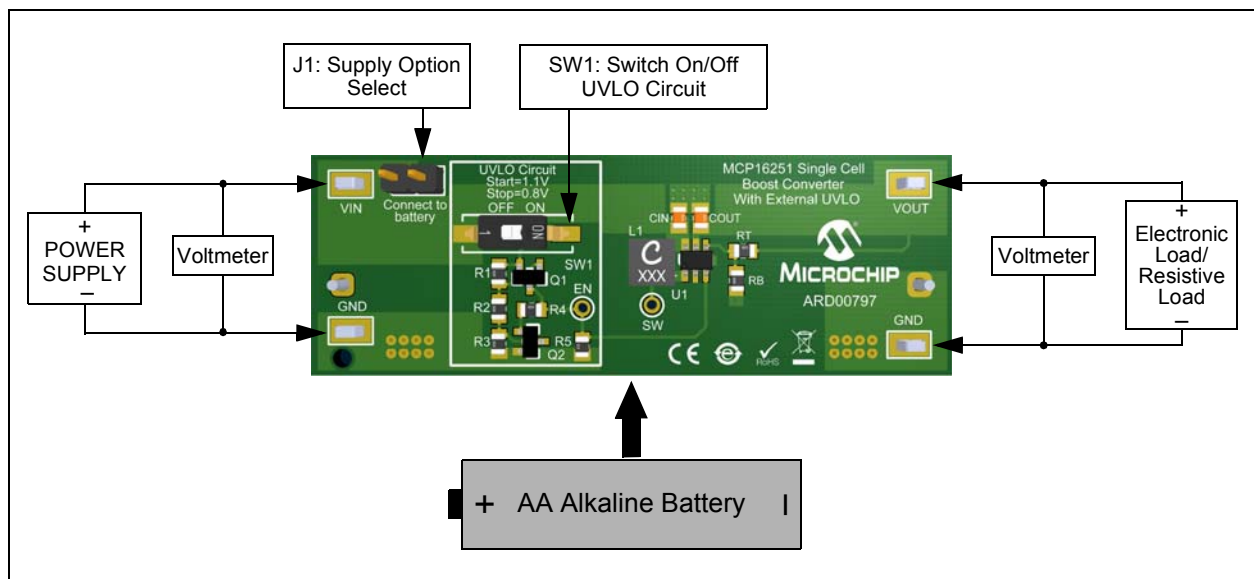

**FIGURE 2-3:** MCP16251 One-Cell Boost Converter with External UVLO Circuit Setup.

# MCP16251 One-Cell Boost Converter with External UVLO Circuit

To test the MCP16251 One-Cell Boost Converter with External UVLO Circuit, follow the following steps:

1. Make sure SW1 is in the Off position.
2. Insert an AA alkaline battery in the holder, paying attention to the polarity. Also, make sure jumper J1 “Connect to battery” is placed (shorted).
3. Connect a resistive or an electronic load and a voltmeter between the  $V_{OUT}$  and GND test pads, as shown in [Figure 2-3](#).
4. Switch SW1 in the On position to enable the UVLO circuit.
5. Measure the input voltage between the  $V_{IN}$  and GND test pads. Also, measure the voltage at the EN test point. If  $V_{IN}$  is higher than 1.1V, the EN voltage should be approximately equal to the input voltage.
6. Measure the output voltage; it should be 3.3V.
7. Switch SW1 Off or decrease  $V_{IN}$  below 0.8V and measure the output voltage; it should be 0V.

## 2.2.1.3 TEST PADS, TEST POINTS AND JUMPERS

Several external test pads, test points and a jumper are placed on the top side of the PCB:

- Jumper

J1 “Connect to battery” for selecting between battery or external power supply. J1 shorted connects  $V_{IN}$  to the battery’s positive terminal.

- Test Pads

$V_{IN}$  For measuring the input voltage or powering the board from an external supply.

$V_{OUT}$  For connecting the load and measuring the output voltage.

GND Connected to the battery’s negative terminal.

- Test Points

EN For measuring the enable signal. It is connected to the MCP16251 device’s EN pin.

SW Connected to the switching node.

## 2.2.2 MCP16251 One-Cell Boost Converter with External UVLO Circuit Operation

**Note:** MCP16251 device’s enable pin is a logic-level input used to enable or disable device switching. A logic high (>70% of  $V_{IN}$ ) on the EN pin will start the output regulation and a logic low (<20% of  $V_{IN}$ ) will ensure that the IC is disabled.

The board can be powered from an AA alkaline battery, which typically has 2500 mAh capacity at low currents, as specified by OEM. If jumper J1 “Connect to battery” is on (connected) and switch SW1 is turned off, the application will start in Sleep mode. While in this state, the EN voltage is 0V (because it is being pulled down by resistor R5) and the Boost Converter is disabled. Turning SW1 on, the UVLO circuit is active and starts monitoring the  $V_{IN}$  voltage. If the battery voltage is higher than 1.1V, transistor Q1 turns on, injecting current in the base of transistor Q2, which also turns on and biases resistor R3. This causes the voltage at the EN pin to go high. Because resistor R5 acts as a load for transistor Q1, the collector current of Q1 is small, meaning its Collector-Emitter Saturation Voltage,  $V_{CE}$ , can be neglected; thus,  $V_{EN} \approx V_{IN}$  and the MCP16251 turns on.

As transistor Q2 bypasses resistor R3, its Base-Emitter Voltage,  $V_{BE}$ , begins to grow, keeping transistor Q1 on as long as  $V_{IN} > 0.8V$ . Transistor Q2 and resistor R3 form the hysteresis block.

When  $V_{IN}$  drops below 0.8V, the Base-Emitter Voltage of transistor Q1 becomes too small, turning the transistor off. This pulls EN to Ground through the pull-down resistor R5, thus shutting down the MCP16251.

Both thresholds are programmable and new values can be easily calculated using [Equations 2-1](#) and [2-2](#).

### EQUATION 2-1:

$$UVLO_{START} \cong V_{EBQ1} \times \frac{(R_1 + R_2 + R_3)}{R_1}$$

Where:

$UVLO_{START}$  = Start-up Voltage Threshold

$V_{EBQ1}$  = Emitter-Base Voltage of Transistor Q1

### EQUATION 2-2:

$$UVLO_{STOP} \cong V_{EBQ1} \times \frac{(R_1 + R_2 + R_3 // R_{CEQ2})}{R_1} \cong V_{EBQ1} \times \frac{(R_1 + R_2)}{R_1} + V_{CE_{SAT}Q2}$$

Where:

$UVLO_{STOP}$  = Shutdown Voltage Threshold

$V_{EBQ1}$  = Emitter-Base Voltage of Transistor Q1

$V_{CE_{SAT}Q2}$  = Collector-Emitter Saturation Voltage of Q2

$V_{EBQ1}$  is approximately 0.4V for the selected MΩ resistors range. It increases up to 0.6V if the resistors are in the kΩ range.

$V_{CESATQ2}$  is approximately 0.1-0.2 V.

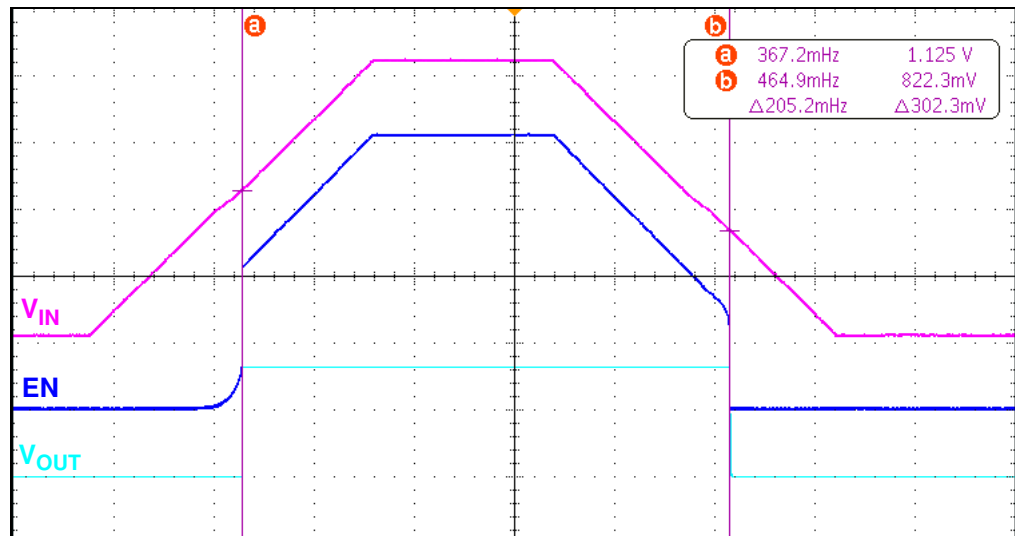

**FIGURE 2-4:**  $V_{IN}$ , EN and  $V_{OUT}$  Waveforms at  $V_{OUT} = 3.3V$  and  $I_{OUT} = 10\text{ mA}$ .

The UVLO circuit operates as a comparator with hysteresis monitoring the input voltage and disabling the converter, via the EN/SHDN pin, when the comparator trips ([Figure 2-4](#)). The hysteresis ensures a clean “High” – “Low” transition, even in noisy environments and is depicted in [Figure 2-5](#).

# MCP16251 One-Cell Boost Converter with External UVLO Circuit

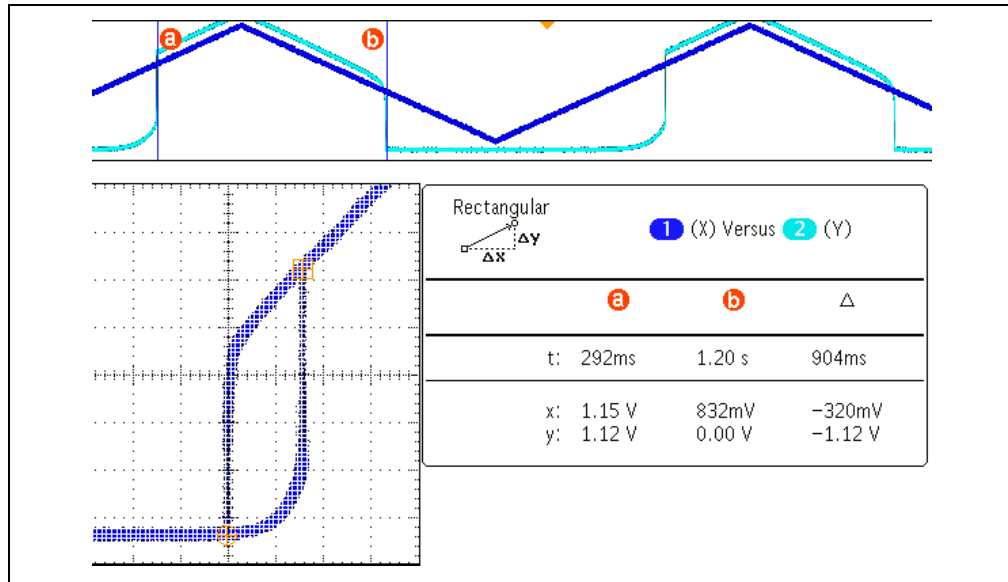

**FIGURE 2-5:** Board Hysteresis Profile; X-Axis is  $V_{IN}$  and Y-Axis is  $EN$ .

The UVLO circuit consumes approximately 0.2  $\mu A$  before start-up and 1.6-2  $\mu A$  when the Boost Converter is switching. Figure 2-6 shows the UVLO circuit current consumption vs. the input voltage.

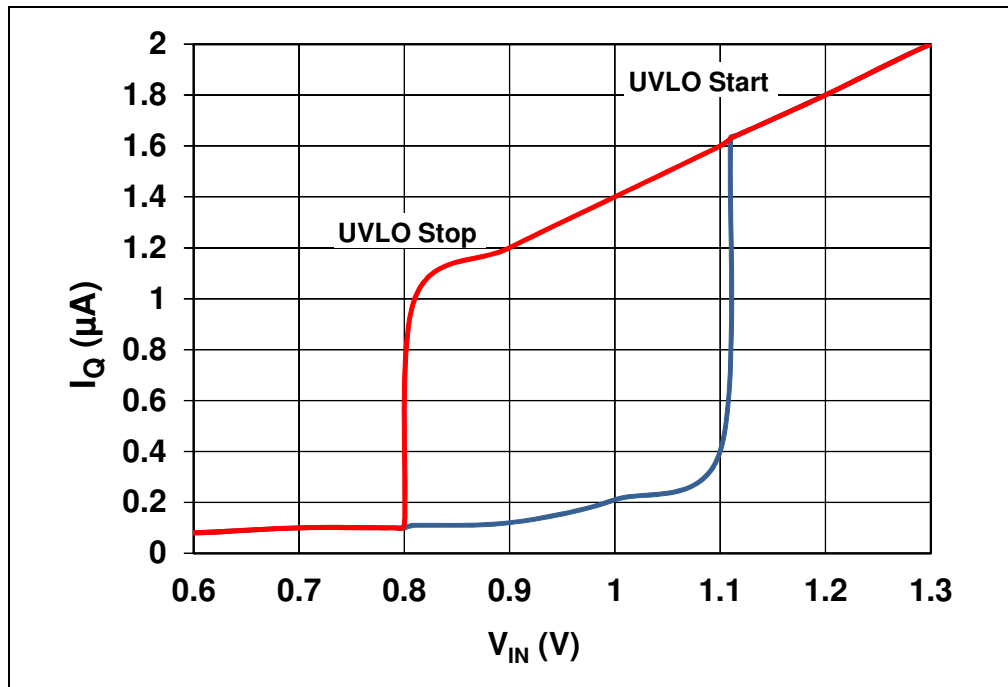

**FIGURE 2-6:** UVLO Circuit Current Consumption vs. Input Voltage.



# MCP16251 ONE-CELL BOOST CONVERTER WITH EXTERNAL UVLO CIRCUIT

---

---

## Appendix A. Schematic and Layouts

---

---

### A.1 INTRODUCTION

This appendix contains the following schematics and layouts for the MCP16251 One-Cell Boost Converter with External UVLO Circuit:

- [Board – Schematic](#)
- [Board – Top Silk and Pads](#)
- [Board – Top Copper](#)
- [Board – Bottom Silk and Pads](#)
- [Board – Bottom Copper](#)
- [Board – Top 3D View](#)
- [Board – Bottom 3D View](#)



## A.2 BOARD – SCHEMATIC

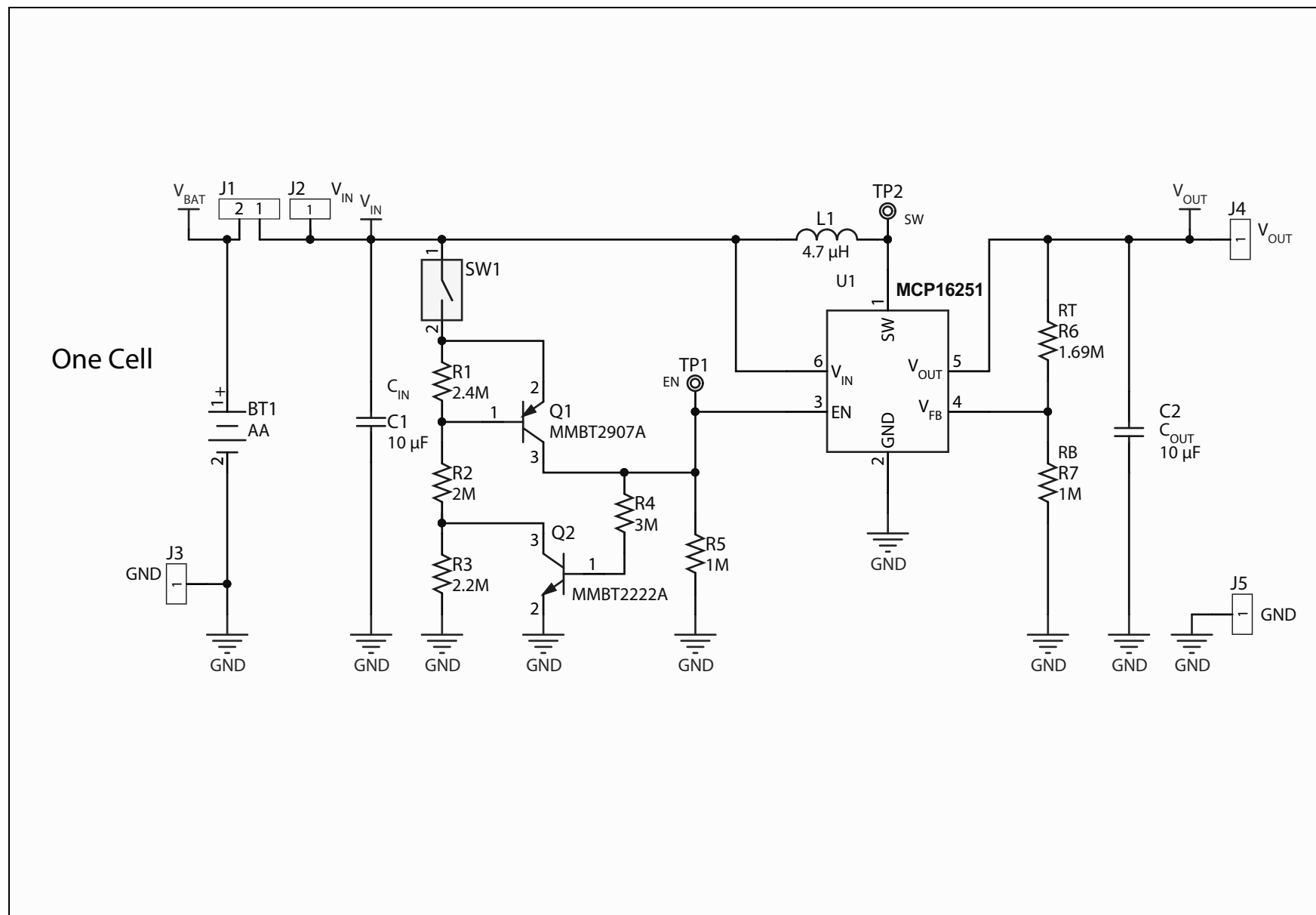

A.3 BOARD – TOP SILK AND PADS

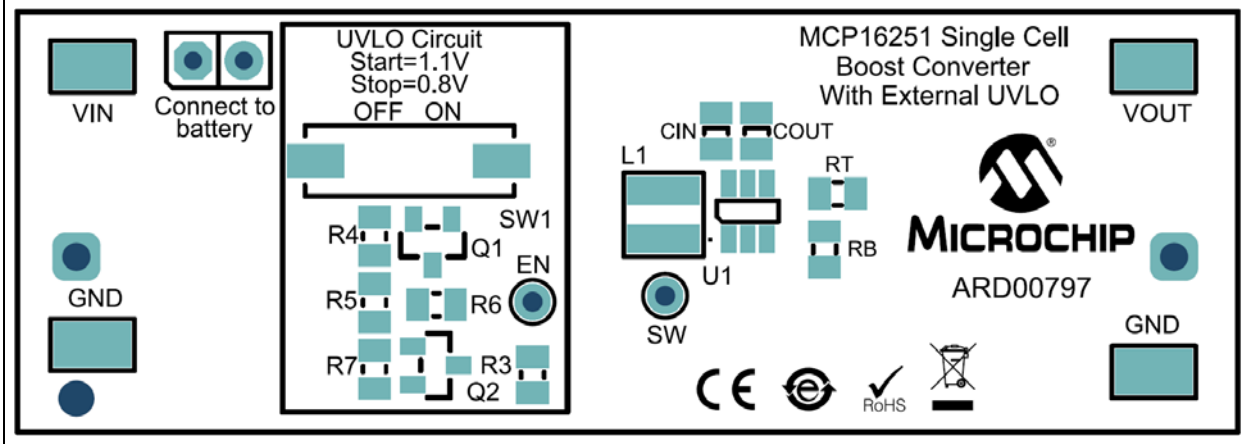

A.4 BOARD – TOP COPPER

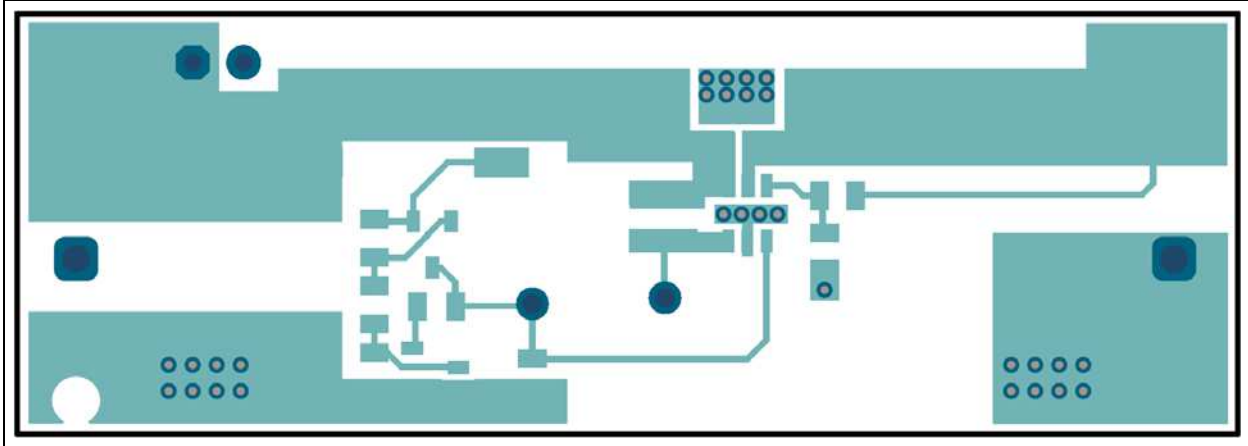

# MCP16251 One-Cell Boost Converter with External UVLO Circuit

## A.5 BOARD – BOTTOM SILK AND PADS

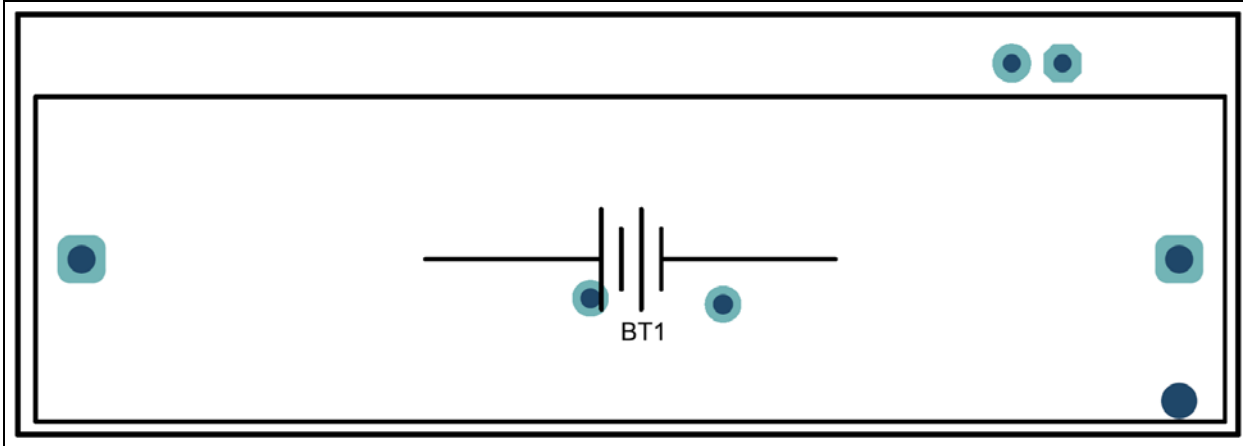

## A.6 BOARD – BOTTOM COPPER

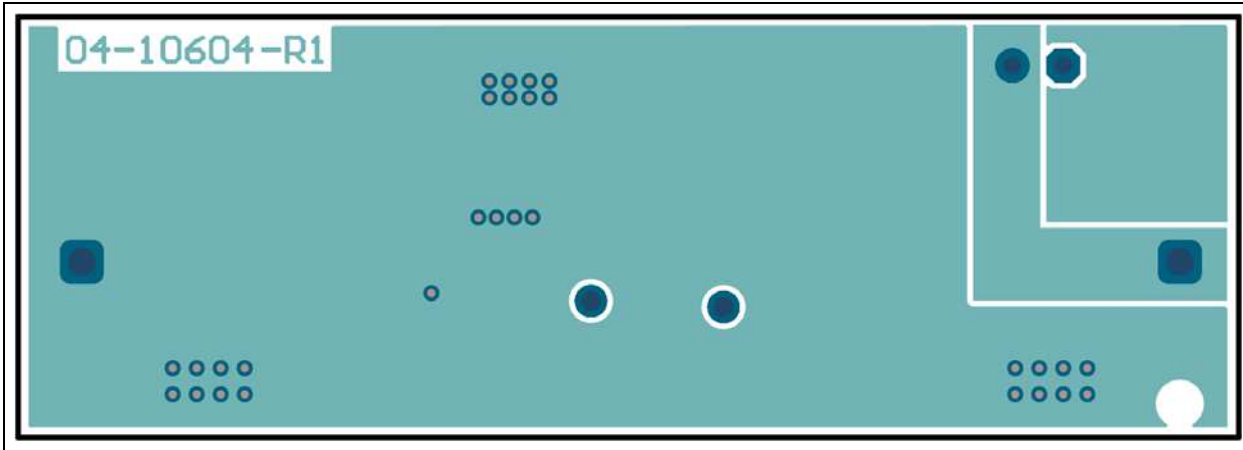

A.7 BOARD – TOP 3D VIEW

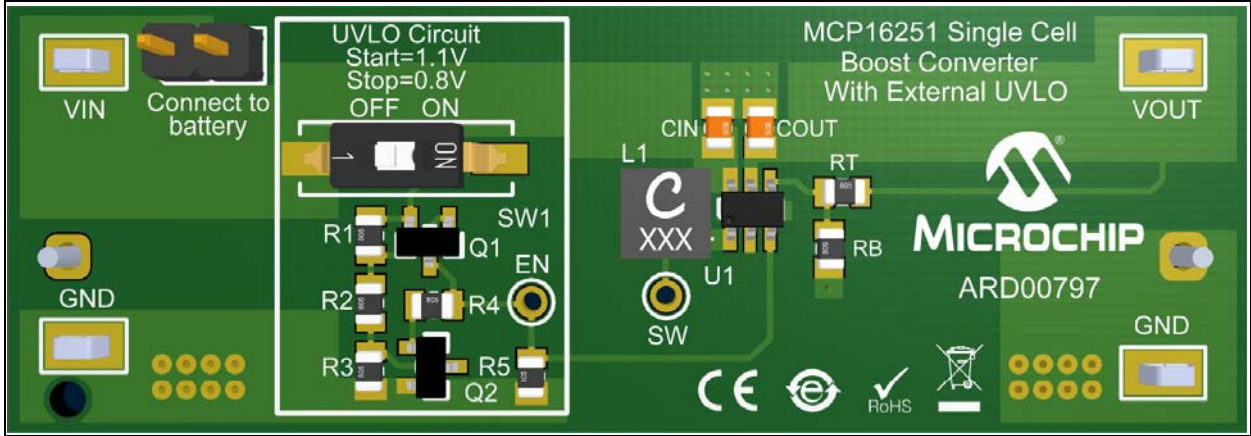

A.8 BOARD – BOTTOM 3D VIEW

