



Chipsmall Limited consists of a professional team with an average of over 10 year of expertise in the distribution of electronic components. Based in Hongkong, we have already established firm and mutual-benefit business relationships with customers from,Europe,America and south Asia,supplying obsolete and hard-to-find components to meet their specific needs.

With the principle of "Quality Parts,Customers Priority,Honest Operation,and Considerate Service",our business mainly focus on the distribution of electronic components. Line cards we deal with include Microchip,ALPS,ROHM,Xilinx,Pulse,ON,Everlight and Freescale. Main products comprise IC,Modules,Potentiometer,IC Socket,Relay,Connector.Our parts cover such applications as commercial,industrial, and automotives areas.

We are looking forward to setting up business relationship with you and hope to provide you with the best service and solution. Let us make a better world for our industry!



Contact us

Tel: +86-755-8981 8866 Fax: +86-755-8427 6832

Email & Skype: info@chipsmall.com Web: www.chipsmall.com

Address: A1208, Overseas Decoration Building, #122 Zhenhua RD., Futian, Shenzhen, China



1-PORT 100BASE-T SMD RJ45 WITH INTEGRATED MAGNETICS

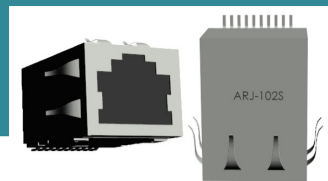

ARJ-102S

23.05 x 16.80 x 13.65mm
RoHS/RoHS II Compliant

FEATURES

- 10/100/1000Base-T compatibility
- Surface mount device
- Wide -40C to 85C operating temperature range
- Integrated magnetics
- Integrated shielding and metal fingers for excellent EMI performance

APPLICATIONS

- Industrial IoT/IoT
- Video IP cameras
- Machine-to-machine (M2M)
- Industrial process control
- Industrial robotics

STANDARD SPECIFICATIONS

PARAMETERS	MINIMUM	TYPICAL	MAXIMUM	UNITS	NOTES
Turn Ratio ($\pm 3\%$)	1CT:1CT				
Inductance	350			μH	100kHz, 0.1Vrms, 8mADC
Insertion Loss			-1.0	dB	1-100MHz
Return Loss	-18			dB	1-30MHz
	-15				30-60MHz
	-12				60-80MHz
	-10				80-100MHz
Crosstalk	-37			dB	1-30MHz
	-32				30-60MHz
	-27				60-100MHz
CMR	-35			dB	1-30MHz
	-30				30-100MHz
Hipot	1500 Vrms min				Pri to Sec

REVISED: 08/08/2016

1-PORT 100BASE-T SMD RJ45 WITH INTEGRATED MAGNETICS

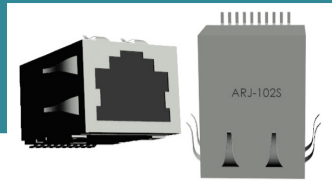

23.05 x 16.80 x 13.65mm
RoHS/RoHS II Compliant

ARJ-102S

PART IDENTIFICATION AND ORDERING INFORMATION

ARJ-102S-



PACKAGING
Blank: Bulk
T:100pcs/reel

MECHANICAL DIMENSIONS: mm (unless otherwise specific, tolerances are ± 0.25)

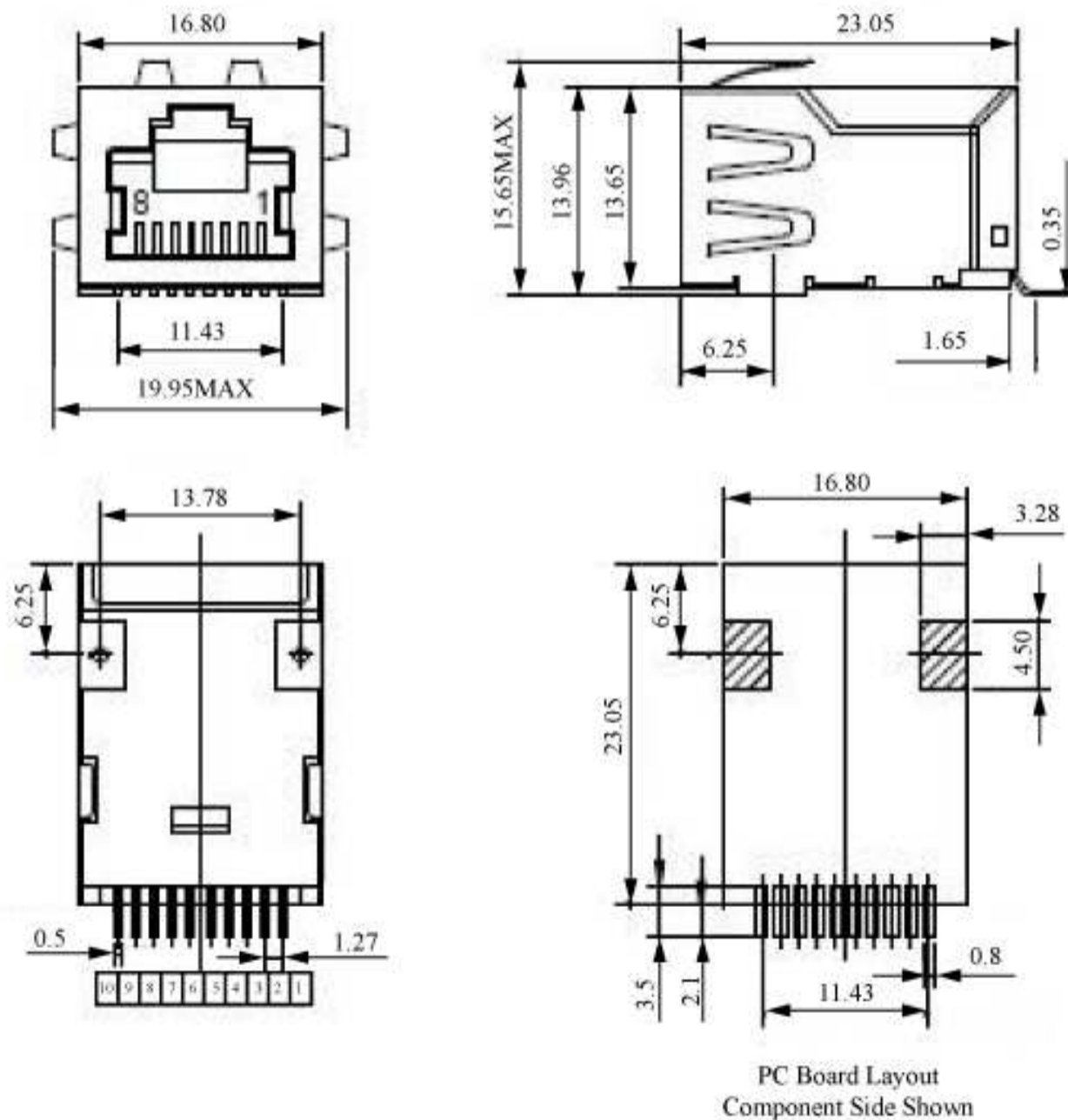

1-PORT 100BASE-T SMD RJ45 WITH INTEGRATED MAGNETICS

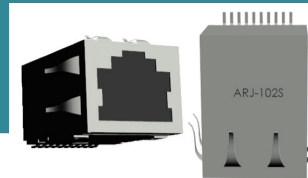

23.05 x 16.80 x 13.65mm
RoHS/RoHS II Compliant

ARJ-102S

SCHEMATIC

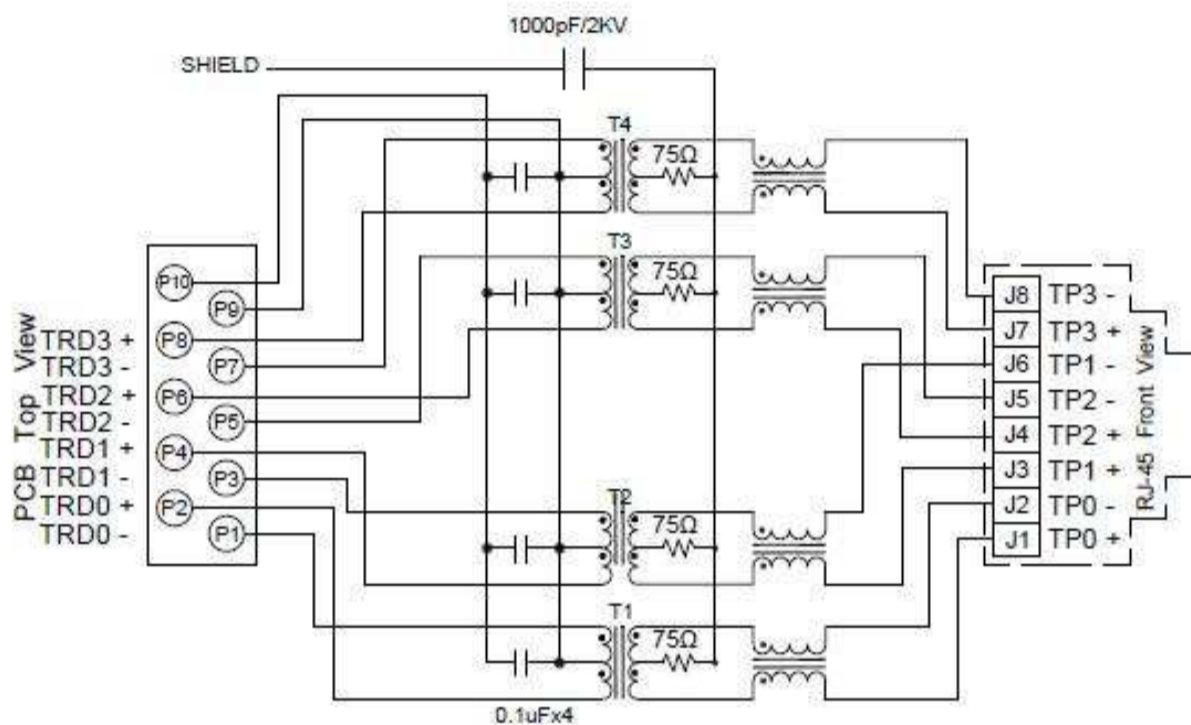

REFLOW

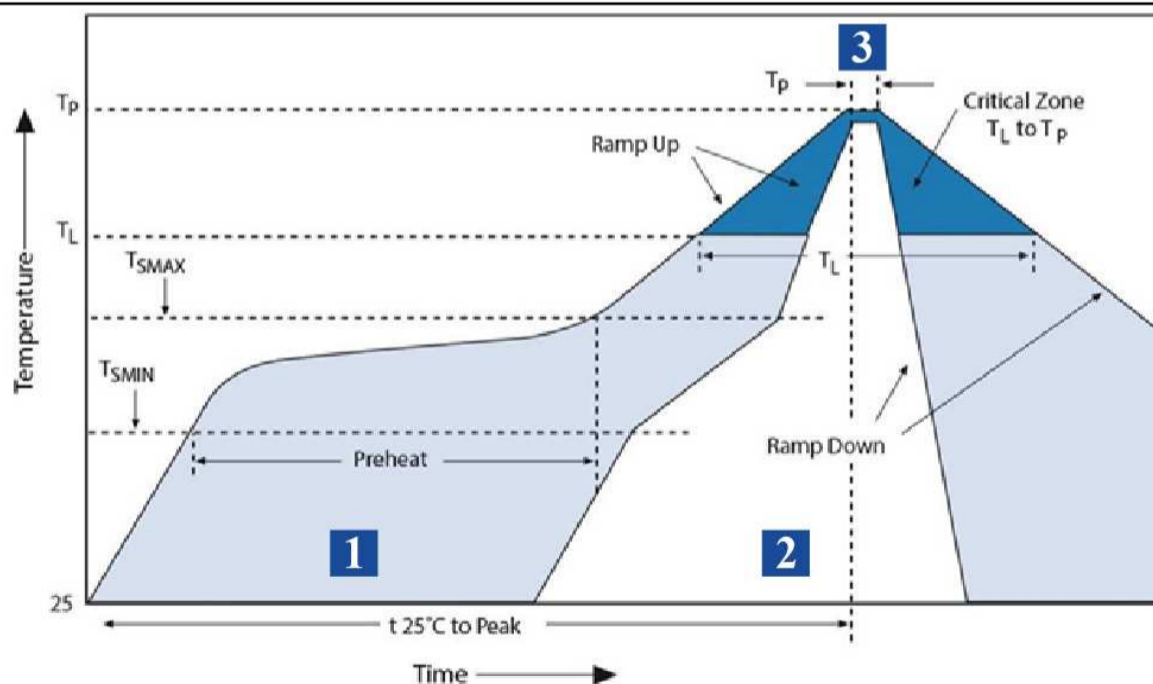

Zone	Description	Temperature	Time
1	Preheat	T _{SMIN} - T _{SMAX} 160°C~180°C	120 sec.
2	Reflow	T _L 60°C	60 sec.
3	Peak Heat	T _p 260°C	10 sec. MAX

REVISED: 08/08/2016

1-PORT 100BASE-T SMD RJ45 WITH INTEGRATED MAGNETICS

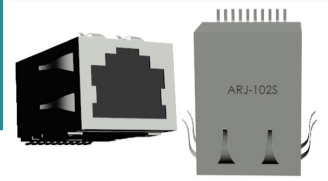

23.05 x 16.80 x 13.65mm
RoHS/RoHS II Compliant

ARJ-102S

PACKAGING

T: 54pcs/tray
Packaging material: PVC
Outer carton unit: 1512 pcs/28trays/box

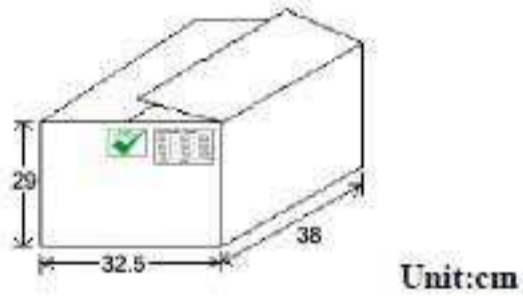
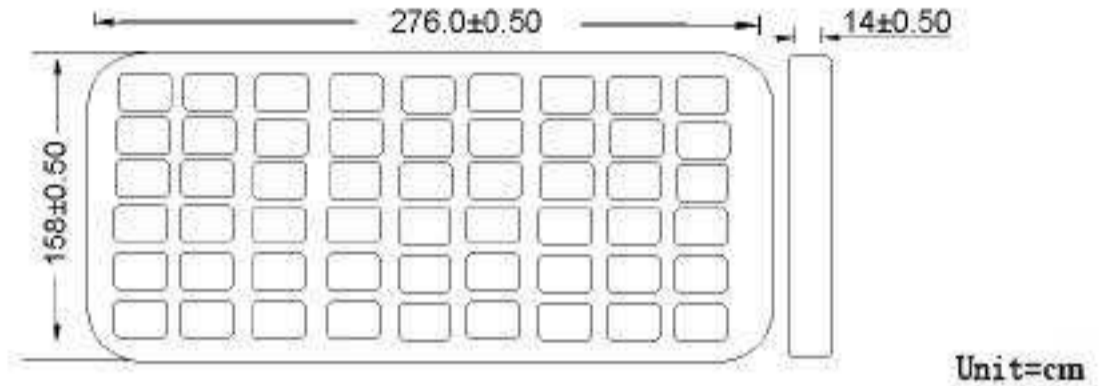

TAPE AND REEL

Weight: 6.9grams/pcs
T&R: 100pcs
Outer carton unit: 600pcs/box or 6T&R/box
Weight: 8.8kg per carton

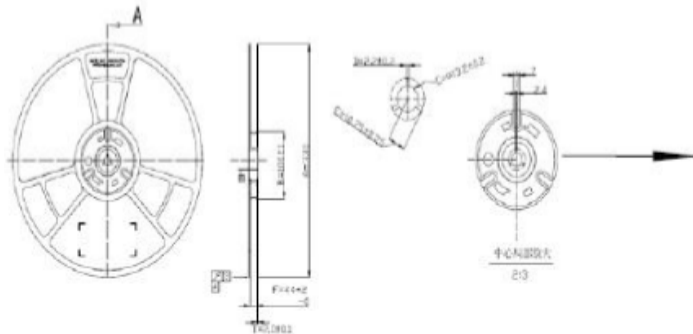
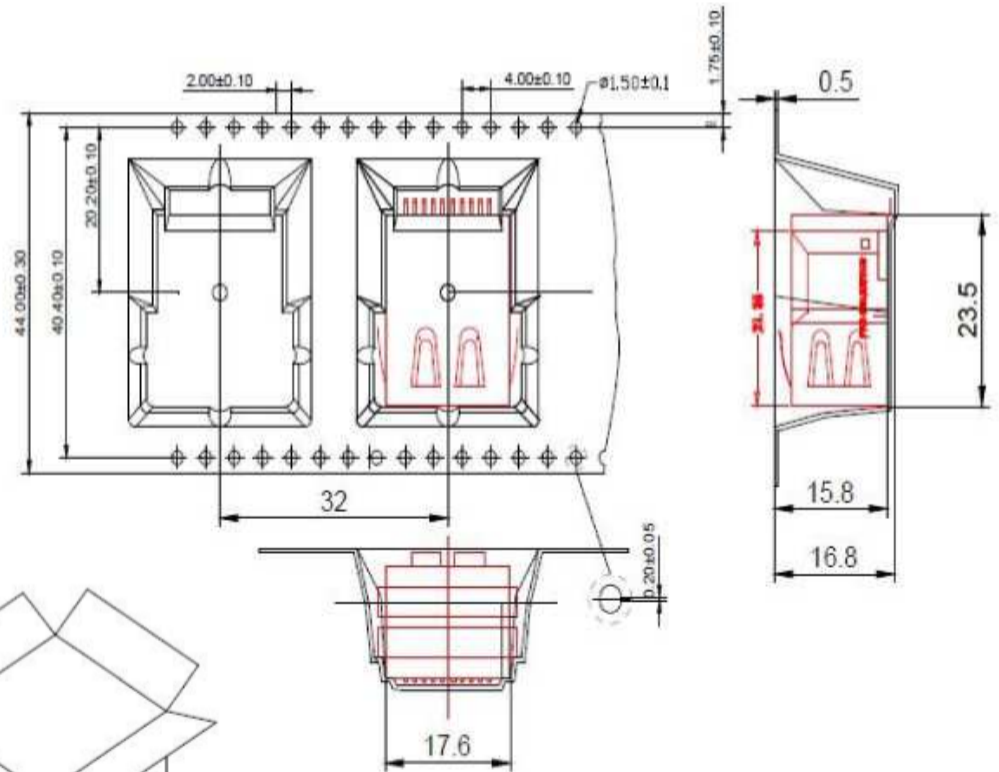

Outer carton: 365x365x350mm

REVISED: 08/08/2016



5101 Hidden Creek Lane Spicewood TX 78669
Phone: 512-371-6159 | Fax: 512-351-8858
For terms and conditions of sale please visit:
www.abracon.com

ABRACON IS
ISO9001-2008
CERTIFIED