



Chipsmall Limited consists of a professional team with an average of over 10 year of expertise in the distribution of electronic components. Based in Hongkong, we have already established firm and mutual-benefit business relationships with customers from,Europe,America and south Asia,supplying obsolete and hard-to-find components to meet their specific needs.

With the principle of “Quality Parts,Customers Priority,Honest Operation,and Considerate Service”,our business mainly focus on the distribution of electronic components. Line cards we deal with include Microchip,ALPS,ROHM,Xilinx,Pulse,ON,Everlight and Freescale. Main products comprise IC,Modules,Potentiometer,IC Socket,Relay,Connector.Our parts cover such applications as commercial,industrial, and automotives areas.

We are looking forward to setting up business relationship with you and hope to provide you with the best service and solution. Let us make a better world for our industry!



## Contact us

Tel: +86-755-8981 8866 Fax: +86-755-8427 6832

Email & Skype: info@chipsmall.com Web: www.chipsmall.com

Address: A1208, Overseas Decoration Building, #122 Zhenhua RD., Futian, Shenzhen, China



# 10/100 Base-Tx Tap Down RJ45 with LED

ARJC02-111009D

RoHS/RoHS II Compliant

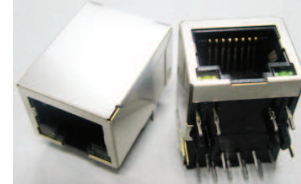

16.0 x 13.55 x 21.1mm

## FEATURES:

- Compliant with IEEE802.3 standard
- 350uH minimum OCL with 8mA bias current
- High performance for maximum EMI suppression
- High reliability – 750 mating/unmating cycles

## APPLICATIONS:

- Designed for most leading PHY IC manufacturers such as Broadcom, Marvell, Microsemi.
- Supports 10/100 Base-T applications
- Provides signal conditioning, EMI suppression and signal isolation.

## STANDARD SPECIFICATIONS

Operating temperature range: 0°C to +70°C Storage temperature range: -25°C to +85°C

Standard Electrical Specifications @25°C

Parameters	Minimum	Typical	Maximum	Units	Notes
Turn Ratio ( $\pm 3\%$ )	1CT:1CT				Tx and Rx
Inductance	350			uH	100kHz/0.1V@8mA
Insertion Loss			-1.0	dB	1-100MHz
Return Loss	-18			dB	1-10MHz
	-16				10-30MHz
	-14				30-60MHz
	-12				60-80MHz
	-10				80-100MHz
CMR	-35			dB	1-100MHz
Crosstalk	-35			dB	1-100MHz
Hipot	1500Vrms/1mA/1s				

## MECHANICAL DIMENSIONS

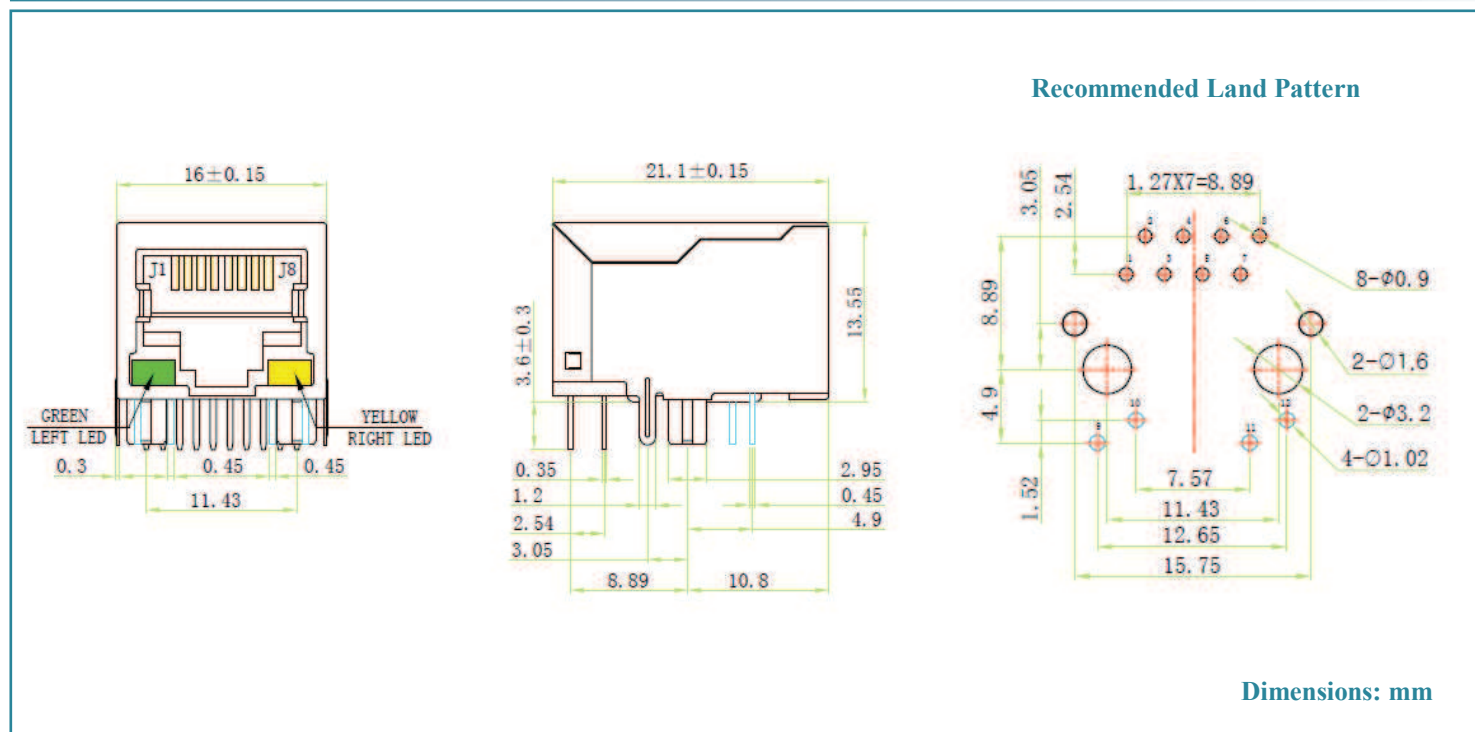



# 10/100 Base-Tx Tap Down RJ45 with LED

ARJC02-111009D

RoHS/RoHS II Compliant

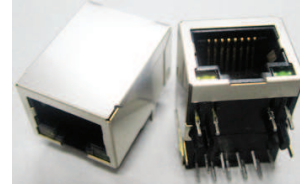

16.0 x 13.55 x 21.1mm

## SCHEMATICS

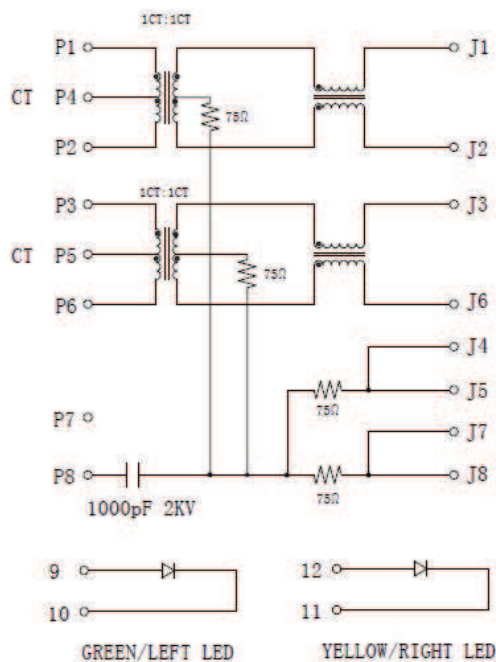

- ◆ CAPACITOR: 1000pF ± 25% 2KV.
- ◆ RESISTANCE: 75OHMS ± 20%.
- ◆ RESISTANCE OF COIL: 1.80HMS MAX, 0.250HMS MIN.

## PACKING:

Packing: (100pcs/tray)

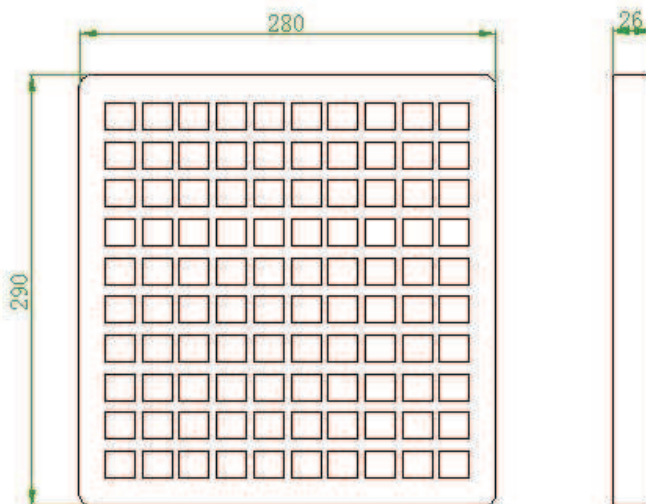

Dimensions: mm

**ATTENTION:** Abracon Corporation's products are COTS – Commercial-Off-The-Shelf products; suitable for Commercial, Industrial and, where designated, Automotive Applications. Abracon's products are not specifically designed for Military, Aviation, Aerospace, Life-dependant Medical applications or any application requiring high reliability where component failure could result in loss of life and/or property. For applications requiring high reliability and/or presenting an extreme operating environment, written consent and authorization from Abracon Corporation is required. Please contact Abracon Corporation for more information.

ABRACON IS  
ISO 9001:2008  
CERTIFIED

 **ABRACON**<sup>®</sup> LLC  
The Power of Linking Together

2 Faraday, Suite# B | Irvine | CA 92618 **Revised: 04.02.15**  
Ph. 949.546.8000 | Fax. 949.546.8001  
Visit [www.abracon.com](http://www.abracon.com) for Terms and Conditions of Sale