



Chipsmall Limited consists of a professional team with an average of over 10 year of expertise in the distribution of electronic components. Based in Hongkong, we have already established firm and mutual-benefit business relationships with customers from,Europe,America and south Asia,supplying obsolete and hard-to-find components to meet their specific needs.

With the principle of “Quality Parts,Customers Priority,Honest Operation,and Considerate Service”,our business mainly focus on the distribution of electronic components. Line cards we deal with include Microchip,ALPS,ROHM,Xilinx,Pulse,ON,Everlight and Freescale. Main products comprise IC,Modules,Potentiometer,IC Socket,Relay,Connector.Our parts cover such applications as commercial,industrial, and automotives areas.

We are looking forward to setting up business relationship with you and hope to provide you with the best service and solution. Let us make a better world for our industry!



## Contact us

Tel: +86-755-8981 8866 Fax: +86-755-8427 6832

Email & Skype: info@chipsmall.com Web: www.chipsmall.com

Address: A1208, Overseas Decoration Building, #122 Zhenhua RD., Futian, Shenzhen, China



# RFID Tag (Passive)

**ART923X855406TX02**

RoHS/RoHS II compliant

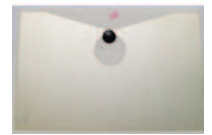

85.0 x 54.0 x 0.635mm

MSL level: Not Applicable

## FEATURES:

- RoHS Compliant
- SMD Type
- High Gain

## TYPICAL APPLICATIONS:

RFID systems for Logistic & Inventory Management of Retail, Pharmaceutical, Automotive Industries; Industrial automation, Contactless smart cards.

## STANDARD SPECIFICATIONS:

Parameters	Min.	Typ.	Max.	Units	Note
Range of Receiving Frequency		902-928		MHz	
Frequency of Lowest Return Loss		915±1.5		MHz	(On TEST Plane)
Tag center frequency		915±5		MHz	(On Metal surface )
GAIN	3.0			dBi	(On70x70 GND Plane)
Polarization Model		Linear			(Right Hand Circular Polarization)
Impedance		ISO18000-6C/EPC		Ω	
Working Temperature		-40~ +85		°C	
Storage Temperature		-40~ +110		°C	
Frequency Temperature Coefficient		0± 10		ppm/°C	
Antenna Reading Range	6.0			m	

## OUTLINE DIMENSION

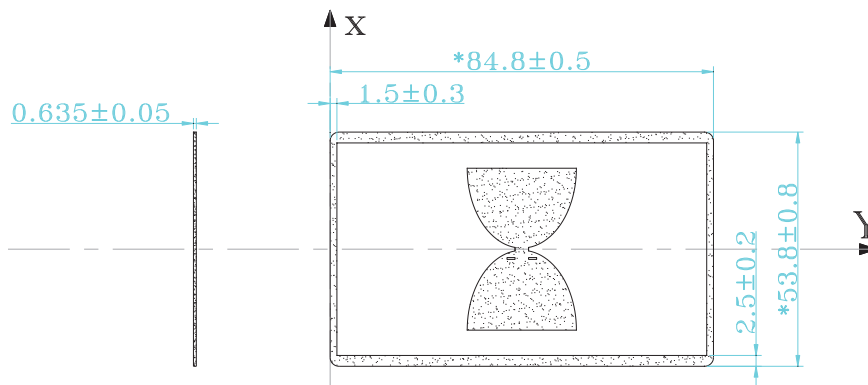

Other Tolerance: ±0.1mm

Unit: mm

# RFID Tag (Passive)

ART923X855406TX02

RoHS/RoHS II compliant



85.0 x 54.0 x 0.635mm

## PACKAGING

Each foam box contains 50pcs of Tag Antenna. There are 12 foam boxes per carton (outer box) with size 345\*210\*275mm

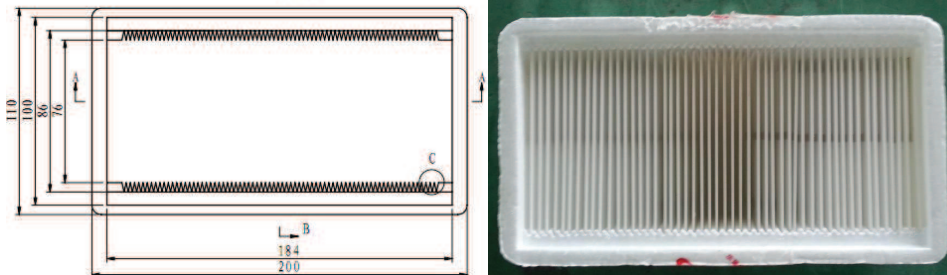

Tray

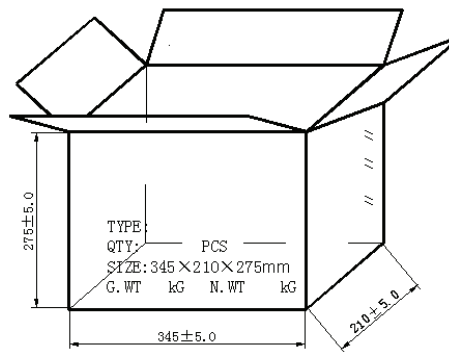

Outer Box

### CAUTION:

- (1) Do not apply excess mechanical stress to the component body or terminations. Do not attempt to re-form or bend the components as this will cause damage to the component.
- (2) Do not expose the component to open flame.
- (3) This specification applies to the functionality of the component as a single unit. Please insure the component is thoroughly evaluated in the application circuit.

### NOTE:

- 1) The parts are manufactured in accordance with this specification. If other conditions and specifications which are required for this specification, please contact ABRACON for more information.
- 2) ABRACON will supply the parts in accordance with this specification unless we receive a written request to modify prior to an order placement.
- 3) In no case shall ABRACON be liable for any product failure from in appropriate handling or operation of the item beyond the scope of this specification.
- 4) When changing your production process, please notify ABRACON immediately.
- 5) ABRACON Corporation's products are COTS – Commercial-Off-The-Shelf products; suitable for Commercial, Industrial and, where designated, Automotive Applications. ABRACON's products are not specifically designed for Military, Aviation, Aerospace, Life-dependant Medical applications or any application requiring high reliability where component failure could result in loss of life and/or property. For applications requiring high reliability and/or presenting an extreme operating environment, written consent and authorization from ABRACON Corporation is required. Please contact ABRACON Corporation for more information.
- 6) All specifications and Marking will be subject to change without notice.

**ATTENTION:** Abracon Corporation's products are COTS – Commercial-Off-The-Shelf products; suitable for Commercial, Industrial and, where designated, Automotive Applications. Abracon's products are not specifically designed for Military, Aviation, Aerospace, Life-dependant Medical applications or any application requiring high reliability where component failure could result in loss of life and/or property. For applications requiring high reliability and/or presenting an extreme operating environment, written consent and authorization from Abracon Corporation is required. Please contact Abracon Corporation for more information.

ABRACON IS  
ISO9001:2008  
CERTIFIED



2 Faraday, Suite# B | Irvine | CA 92618 **Revised: 11.25.14**  
Ph. 949.546.8000 | Fax. 949.546.8001  
Visit [www.abracon.com](http://www.abracon.com) for Terms and Conditions of Sale