



Chipsmall Limited consists of a professional team with an average of over 10 year of expertise in the distribution of electronic components. Based in Hongkong, we have already established firm and mutual-benefit business relationships with customers from,Europe,America and south Asia,supplying obsolete and hard-to-find components to meet their specific needs.

With the principle of “Quality Parts,Customers Priority,Honest Operation,and Considerate Service”,our business mainly focus on the distribution of electronic components. Line cards we deal with include Microchip,ALPS,ROHM,Xilinx,Pulse,ON,Everlight and Freescale. Main products comprise IC,Modules,Potentiometer,IC Socket,Relay,Connector.Our parts cover such applications as commercial,industrial, and automotives areas.

We are looking forward to setting up business relationship with you and hope to provide you with the best service and solution. Let us make a better world for our industry!



Contact us

Tel: +86-755-8981 8866 Fax: +86-755-8427 6832

Email & Skype: info@chipsmall.com Web: www.chipsmall.com

Address: A1208, Overseas Decoration Building, #122 Zhenhua RD., Futian, Shenzhen, China



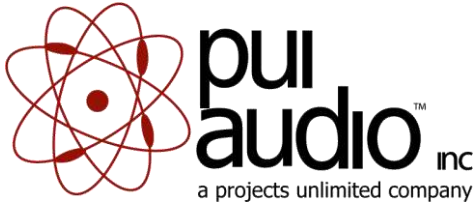

Data Sheet

AS02804PR-N50-R

Introducing the N50 Mini Speaker Series from PUI Audio. High-grade neodymium magnetic motors are employed in each N50 Series speaker to create the highest output possible, in the smallest form factor.

The 28mm diameter **AS02804PR-N50-R** features a paper cone and foam surround for classic HiFi sound quality. Four openings on the back plate create forced-air cooling to dissipate heat from the voice coil.

Features:

- Paper cone and foam surround
- High 76 dB output at 3W/1m
- N50 neodymium motor
- Only 7.5mm thick
- 2mm of excursion

Specifications

| Parameters | Values | Units |
|---|--------------|-------|
| Rated Input Power | 3 | Watts |
| Max Input Power | 4 | Watts |
| Impedance | 4 ± 15% | Ohms |
| Sensitivity (SPL @ 3W/1m) (800, 1000, 1200, and 1500 Hz) | 76.5 ± 3 | dBa |
| Distortion (Max @ 1W, 1 kHz) | <5% | |
| Resonant Frequency | 350 ± 20% | Hz |
| Frequency Range | 250 ~ 20,000 | Hz |
| Housing Material | ABS | |
| Magnet Material | NdFeB | |
| Weight | 10.8 | Grams |

Specifications (continued)

| | | |
|-----------------------|--|----|
| Buzz, Rattle, etc. | Should not be audible with 3.46Vpk sine wave from 280 Hz to 10 kHz | |
| Polarity | When positive voltage is applied to the positive terminal, the diaphragm will move outward | |
| Operating Temperature | -20 ~ +60 | °C |
| Storage Temperature | -30 ~ +70 | °C |

Measurement Method

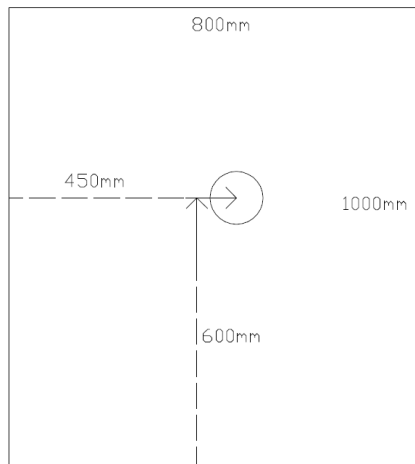

Test Baffle (speaker mounted in circle)

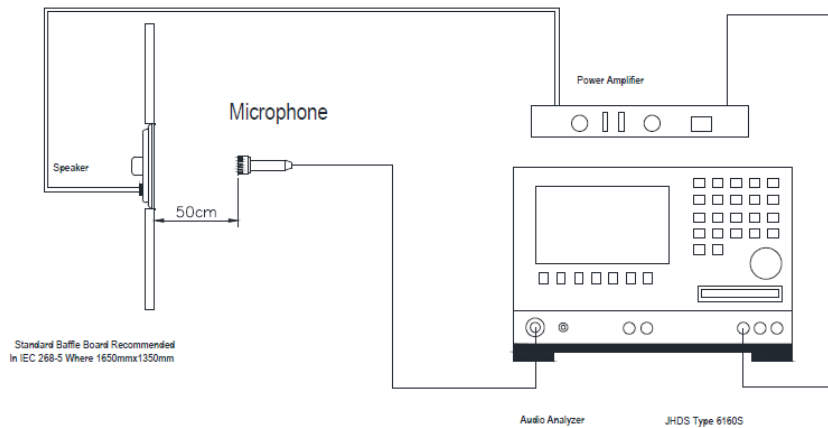

Frequency Response (measured at 1m with 3W of input power)

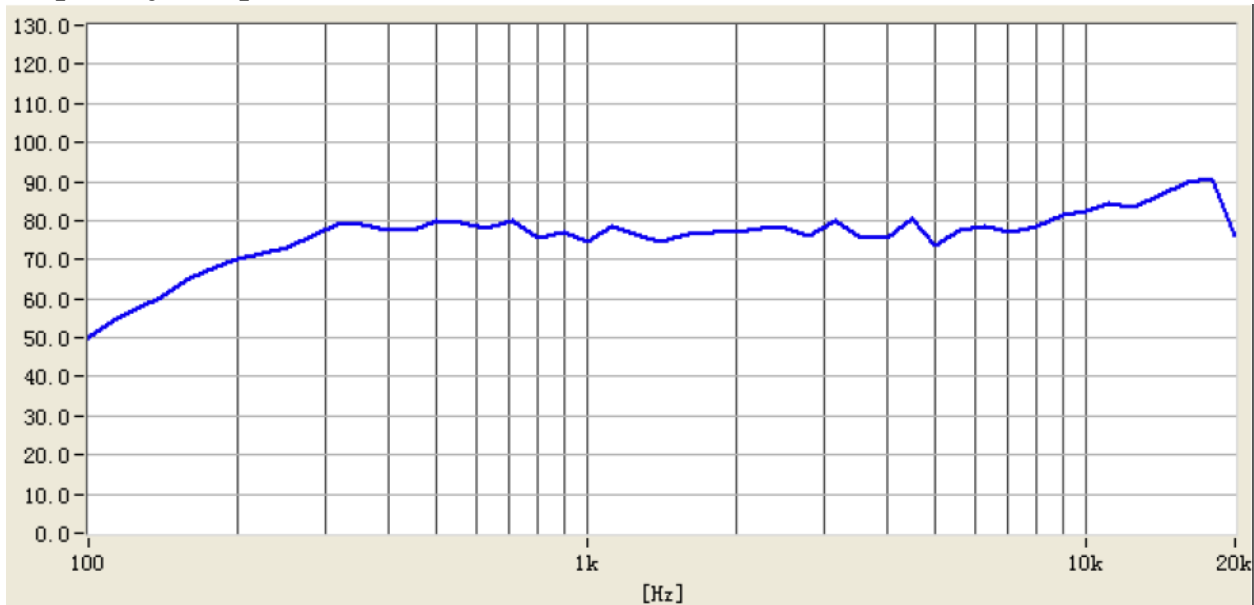

Reliability Testing

| Type of Test | Test Specifications |
|---------------------------|---|
| High Temperature Test | 96 hours at +85°C ± 3°C followed by six hours in normal room temperature |
| Low Temperature Test | 96 hours at -40°C ± 3°C followed by six hours in normal room temperature |
| Humidity Test | 96 hours at +40°C ± 3°C with relative humidity at 92% to 95% followed by 3 hours in normal room temperature |
| Temperature Cycle Testing | <p>The part shall be subjected to 20 cycles using the following procedure:</p> |
| Vibration Test | 10 to 55 to 10 Hz cycles, 15 minutes per cycle. 2 hours in each axis X, Y, and Z. |
| Drop Test | Drop the speakers onto a 40mm thick board 10 times from a height of 75cm. |
| Load Test | Pink noise is applied at the speakers rated power for 96 hours at room temperature |

After each test, the speaker's SPL shall be ±3 dB of the original SPL

Dimensions

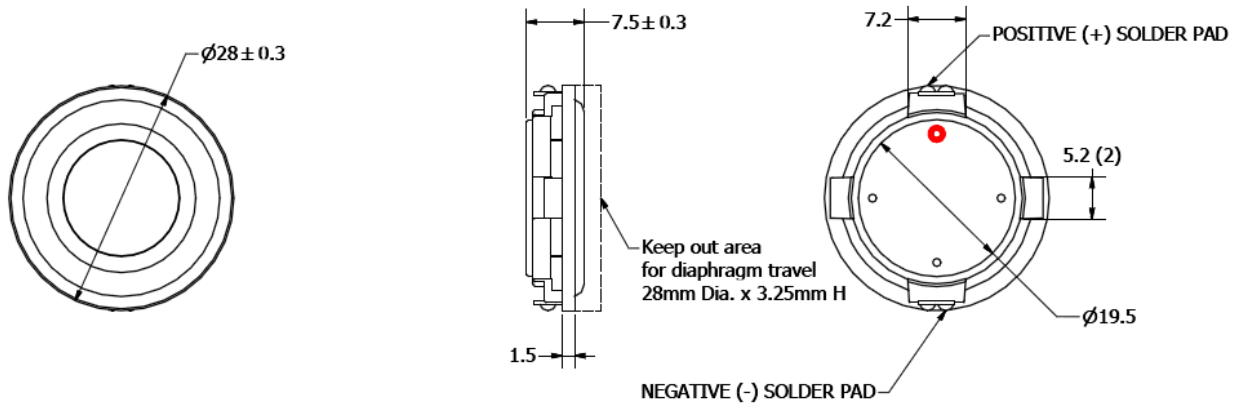

Packaging

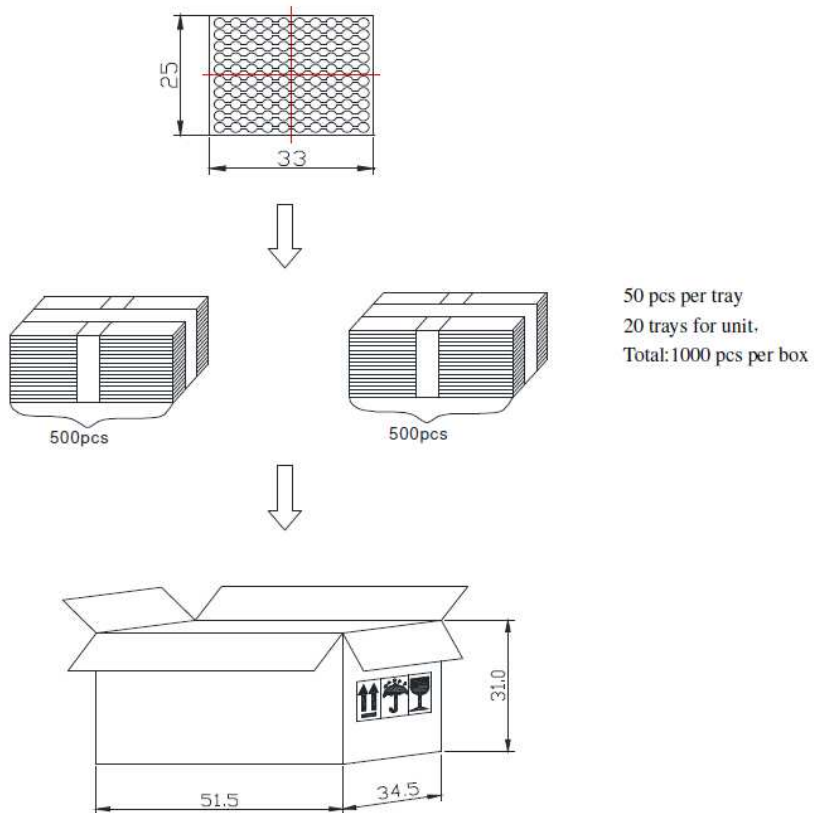

Specifications Revisions

| Revision | Description | Date |
|-----------------|--|-------------|
| | Released from Engineering | 5/11/2017 |
| A | Updated SPL, Weight, and added Packaging Information | 7/13/2017 |

Note:

1. Unless otherwise specified:
 - A. All dimensions are in millimeters.
 - B. Default tolerances are $\pm 0.5\text{mm}$ and angles are $\pm 3^\circ$.
2. Specifications subject to change or withdrawal without notice.
3. This part is RoHS 2011/65/EU Compliant.