



Chipsmall Limited consists of a professional team with an average of over 10 year of expertise in the distribution of electronic components. Based in Hongkong, we have already established firm and mutual-benefit business relationships with customers from,Europe,America and south Asia,supplying obsolete and hard-to-find components to meet their specific needs.

With the principle of “Quality Parts,Customers Priority,Honest Operation,and Considerate Service”,our business mainly focus on the distribution of electronic components. Line cards we deal with include Microchip,ALPS,ROHM,Xilinx,Pulse,ON,Everlight and Freescale. Main products comprise IC,Modules,Potentiometer,IC Socket,Relay,Connector.Our parts cover such applications as commercial,industrial, and automotives areas.

We are looking forward to setting up business relationship with you and hope to provide you with the best service and solution. Let us make a better world for our industry!



## Contact us

Tel: +86-755-8981 8866 Fax: +86-755-8427 6832

Email & Skype: info@chipsmall.com Web: www.chipsmall.com

Address: A1208, Overseas Decoration Building, #122 Zhenhua RD., Futian, Shenzhen, China



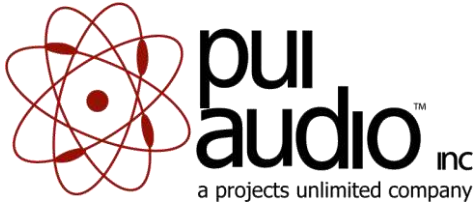

## Data Sheet

AS03104MR-N50-R

Introducing the N50 Mini Speaker Series from PUI Audio. High-grade neodymium magnetic motors are employed in each N50 Series speaker to create the highest output possible, in the smallest form factor.

The 31mm diameter **AS03104MR-N50-R** features a moisture resistant silver poly cone. The foam surround provides progressive damping for low distortion and flat frequency response from 200 Hz to 20 kHz. Twin frame supports makes mounting simple.

### Features:

- Silver poly cone and foam surround
- High 81 dB output at 1W/50cm
- N50 neodymium motor
- Only 15mm thick
- 2mm of excursion

### Specifications

Parameters	Values	Units
Rated Input Power	3	Watts
Max Input Power	5	Watts
Impedance	$4 \pm 15\%$	Ohms
Sensitivity (SPL @ 1W/50cm) (800, 1000, 1200, and 1500 Hz)	$81 \pm 3$	dB
Distortion (Max @ 1W, 1 kHz)	<5%	
Resonant Frequency	$300 \pm 20\%$	Hz
Frequency Range	200 ~ 20,000	Hz
Housing Material	ABS	
Magnet Material	NdFeB	
Weight	31	Grams

## Specifications (continued)

Buzz, Rattle, etc.	Should not be audible with 2.83Vpk sine wave from 300 Hz to 10 kHz	
Polarity	When positive voltage is applied to the positive terminal, the diaphragm will move outward	
Operating Temperature	-20 ~ +60	°C
Storage Temperature	-30 ~ +70	°C

## Measurement Method

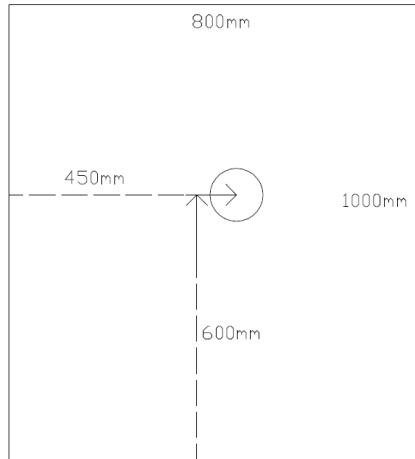

Test Baffle (speaker mounted in circle)

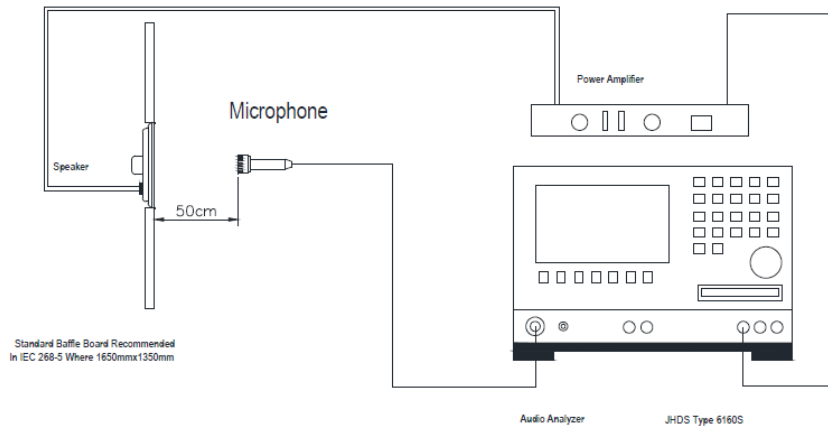

## Frequency Response (measured at 50cm with 1W input power)

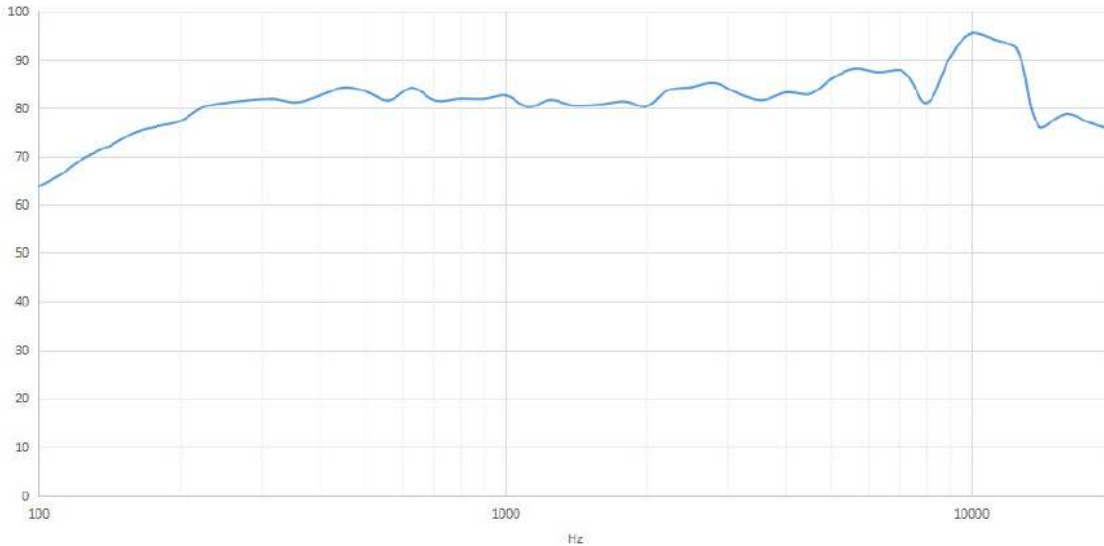

## Reliability Testing

Type of Test	Test Specifications
High Temperature Test	96 hours at +70°C ± 3°C followed by six hours in normal room temperature
Low Temperature Test	96 hours at -30°C ± 3°C followed by six hours in normal room temperature
Humidity Test	96 hours at +40°C ± 3°C with relative humidity at 92% to 95% followed by 3 hours in normal room temperature
Temperature Cycle Testing	<p>The part shall be subjected to 5 cycles using the following procedure:</p>
Vibration Test	10 to 55 to 10 Hz cycles, 15 minutes per cycle. 2 hours in each axis X, Y, and Z.
Drop Test	Drop the speakers onto a 40mm thick board 10 times from a height of 75cm.
Load Test	Pink noise is applied at the speakers rated power for 96 hours at room temperature

**After each test, the speaker's SPL shall be ±3 dB of the original SPL**

## Dimensions

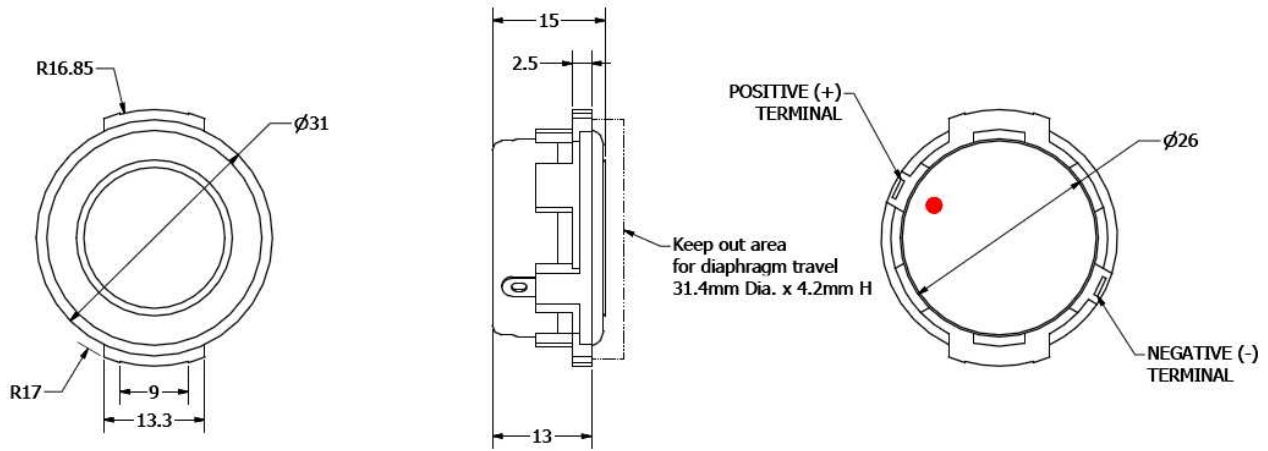

## Packaging

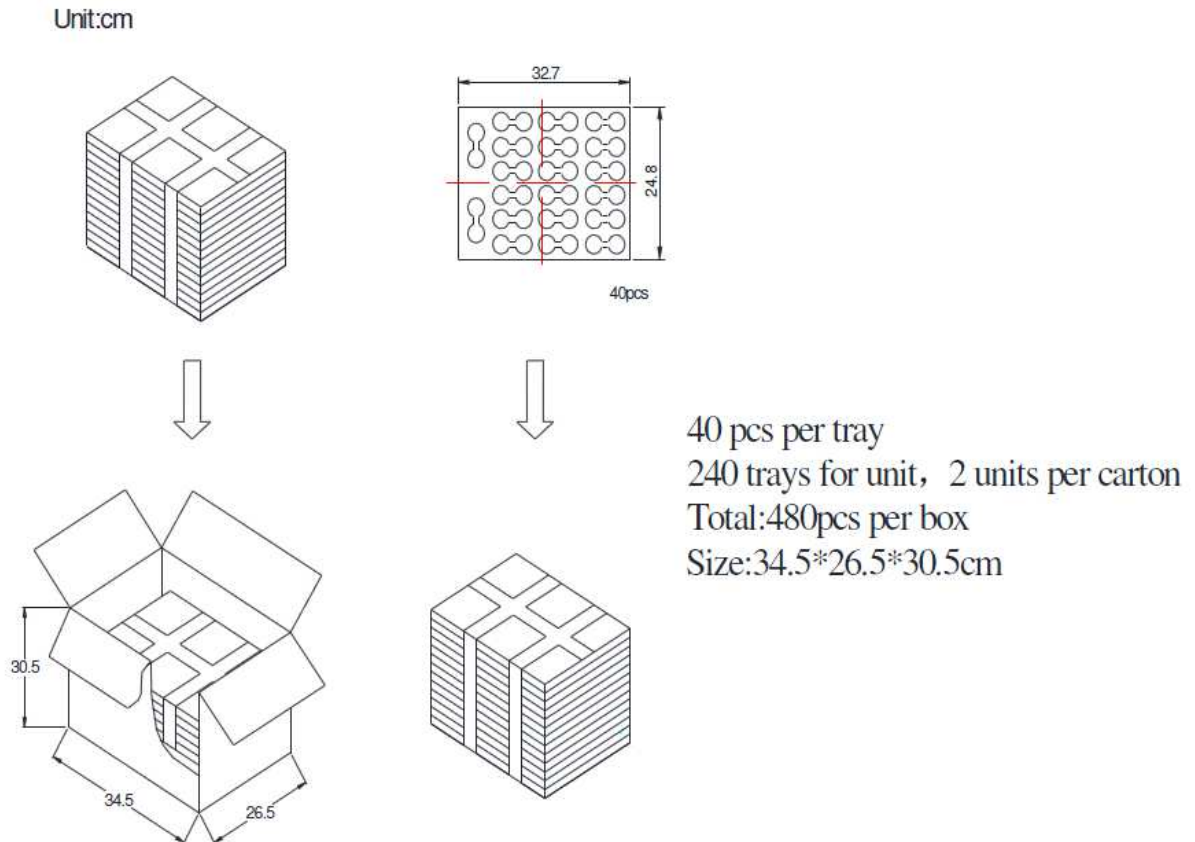

**Specifications Revisions**

<b>Revision</b>	<b>Description</b>	<b>Date</b>
	Released from Engineering	5/11/2017
A	Updated Weight and added Packaging Specifications	7/13/2017

**Note:**

1. Unless otherwise specified:
  - A. All dimensions are in millimeters.
  - B. Default tolerances are  $\pm 0.5\text{mm}$  and angles are  $\pm 3^\circ$ .
2. Specifications subject to change or withdrawal without notice.
3. This part is RoHS 2011/65/EU Compliant.