



Chipsmall Limited consists of a professional team with an average of over 10 year of expertise in the distribution of electronic components. Based in Hongkong, we have already established firm and mutual-benefit business relationships with customers from,Europe,America and south Asia,supplying obsolete and hard-to-find components to meet their specific needs.

With the principle of "Quality Parts,Customers Priority,Honest Operation,and Considerate Service",our business mainly focus on the distribution of electronic components. Line cards we deal with include Microchip,ALPS,ROHM,Xilinx,Pulse,ON,Everlight and Freescale. Main products comprise IC,Modules,Potentiometer,IC Socket,Relay,Connector.Our parts cover such applications as commercial,industrial, and automotives areas.

We are looking forward to setting up business relationship with you and hope to provide you with the best service and solution. Let us make a better world for our industry!



Contact us

Tel: +86-755-8981 8866 Fax: +86-755-8427 6832

Email & Skype: info@chipsmall.com Web: www.chipsmall.com

Address: A1208, Overseas Decoration Building, #122 Zhenhua RD., Futian, Shenzhen, China



AS1101, AS1102, AS1103, AS1104

Low-Dropout LED Drivers

Data Sheet

1 General Description

The AS1101/AS1102/AS1103/AS1104 are LED drivers designed to match current source bias for any color LED, including white and blue. The devices can drive up to 4 high-current LEDs, and the LED current is programmable using an external resistor (RSET).

The AS1101 LED currents are $460 \times I_{SET}$ (per LED, typ) at an LED cathode voltage (V_{SAT}) of 150mV and $650 \times I_{SET}$ (typ) at a V_{SAT} of 1V, where I_{SET} is the current through RSET connected to pin CTRL.

The AS1102, AS1103, and AS1104 LED currents are $230 \times I_{SET}$ (per LED, typ) at a V_{SAT} of 150mV and $325 \times I_{SET}$ (typ) at a V_{SAT} of 1V.

The AS1101, AS1102, and AS1104 incorporate a chip-enable feature via pin ON. When the devices are disabled, the supply current drops to less than $1\mu A$.

The AS1101, AS1102, and AS1103 are available in a 6-pin SC70 package; the AS1104 is available in a 8-pin MSOP package.

2 Key Features

- LED Drivers for Parallel-Connected LEDs
- Ultra-Low Voltage Drop: Less Than 150mV (for Li-ion Battery Support)
- Analog and PWM Brightness Control
- Up to 80mA per LED (AS1101)
- Up to 40mA per LED (AS1102, AS1103, AS1104)
- No Electromagnetic Interference, No Switching-Noise
- Current-Matching Requires No External Components
- Active-Low Shutdown Mode (AS1101, AS1102, and AS1103)
- Low Shutdown-Current: Less Than $1\mu A$
- SC70-6 Package (AS1101, AS1102, and AS1103)
- MSOP-8 Package (AS1104)

3 Applications

The AS110x devices are ideal for LED displays and keyboard backlights, as well as lighting management units for battery powered audio devices such as MP3 and CD players, mobile and cordless phones, PDAs, portable DVD players, and consumer electronics.

Figure 1. Typical Application Diagrams

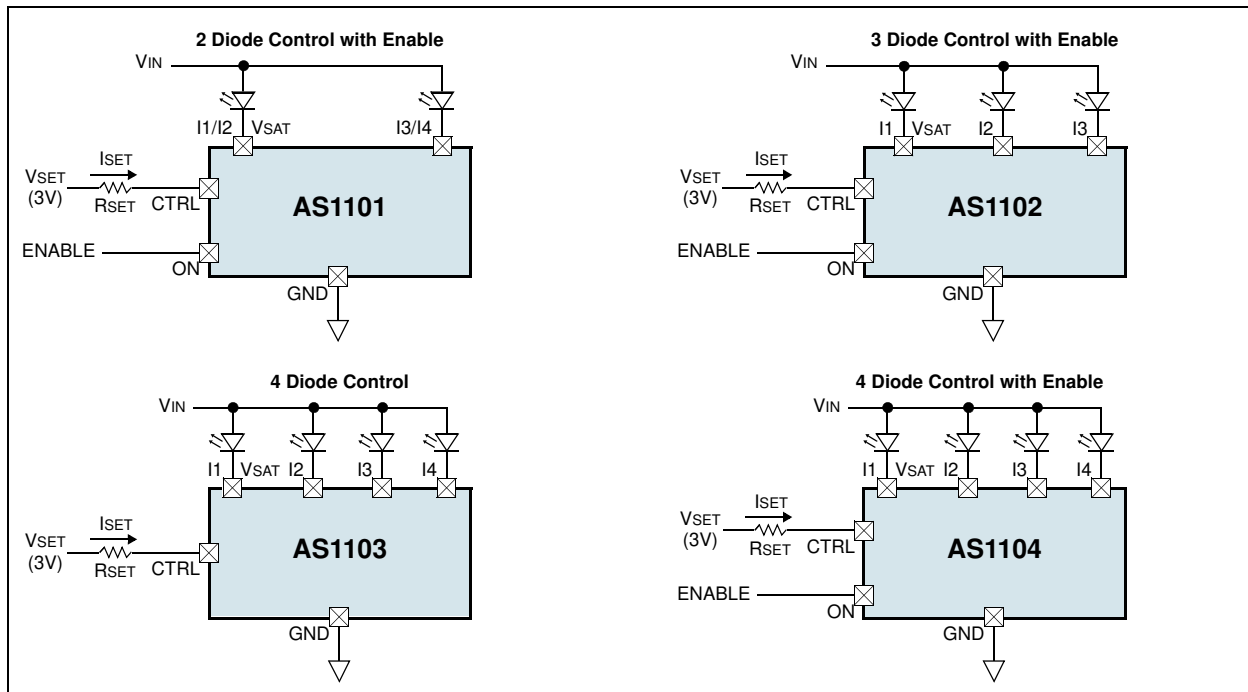

4 Pinout

Pin Assignments

Figure 2. Pin Assignments – (Top View)

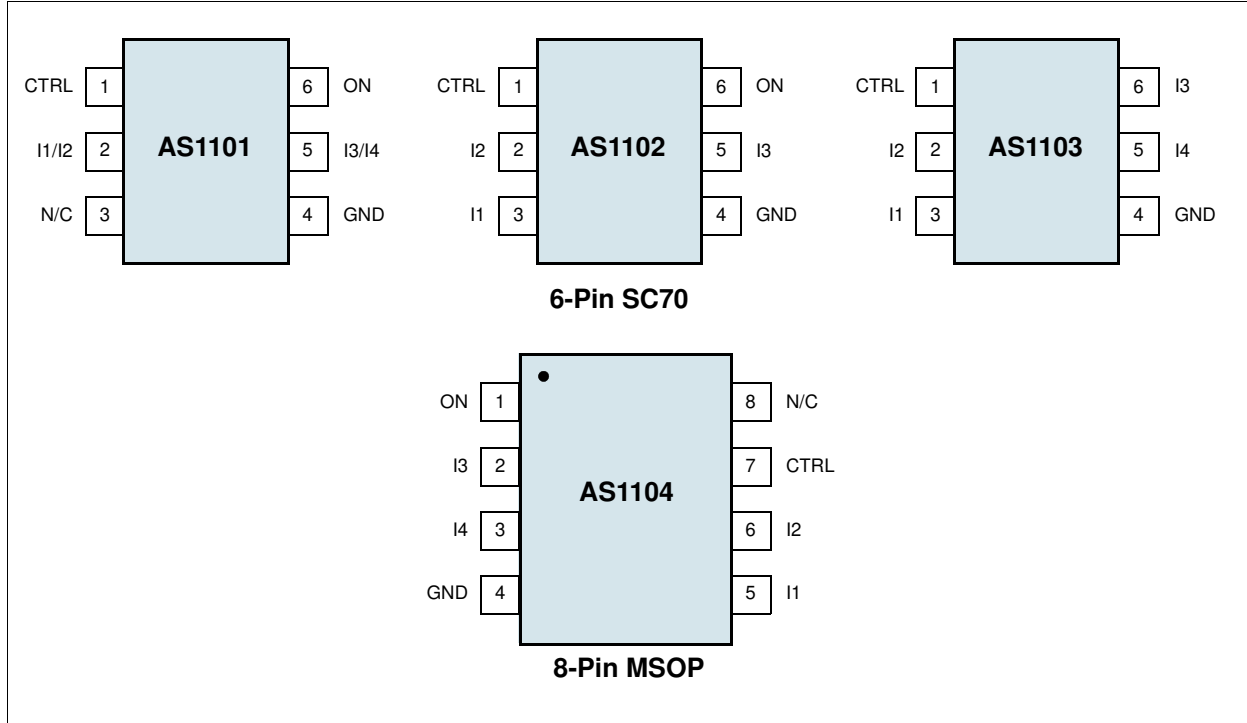

Pin Descriptions

Table 1. Pin Descriptions

Pin Number	Pin Name	Description
(see Figure 2)	CTRL	Sets LED current; connect to external resistor.
	I1	Connect to cathode of LED.
	I2	Connect to cathode of LED.
	I3	Connect to cathode of LED.
	I4	Connect to cathode of LED.
	GND	Ground
	ON	Device Enable Input.

5 Absolute Maximum Ratings

Stresses beyond those listed in [Table 2](#) may cause permanent damage to the device. These are stress ratings only, and functional operation of the device at these or any other conditions beyond those listed in [Electrical Characteristics on page 4](#) is not implied. Exposure to absolute maximum rating conditions for extended periods may affect device reliability.

Table 2. Absolute Maximum Ratings

Parameter	Min	Max	Unit	Comment
V _{I1} , V _{I2} , V _{I3} , V _{I4} , CTRL and ON Voltage to GND	-0.3	5	V	
Power Dissipated by Device at T _{AMB} = 85°C		200	mW	SC70-6
		250	mW	MSOP-8
I ₁ , I ₂ , I ₃ , I ₄ Steady State Current		100	mA	
Package Body Temperature †		260	°C	
Junction Temperature		150	°C	
Storage Temperature	-65	150	°C	
Electrostatic Discharge Protection (ESD) Level	2		kV	Human Body Model; Norm: MIL-STD883E 3015 methods.

† The reflow peak soldering temperature (body temperature) is specified according to IPC/JEDEC J-STD-020C "Moisture/Reflow Sensitivity Classification for Non-Hermetic Solid State Surface Mount Devices".

Operating Conditions

Table 3. Recommended Operating Conditions

Parameter	Min	Typ	Max	Unit	Comments
LED Cathode Voltage	0.15	0.6	3.6	V	
Enable Voltage ON Mode †	2.2	3.0	3.6	V	
Enable Voltage OFF Mode †	0	0.2	0.5	V	
Ambient Temperature	-40	25	85	°C	

† Not applicable to AS1103.

6 Electrical Characteristics

AS1101 Electrical Characteristics

$T_{AMB} = 25^{\circ}\text{C}$ (unless otherwise noted).

Table 4. Electrical Characteristics – AS1101

Parameter	Symbol	Conditions	Min	Typ	Max	Units
ISET Range	ISET	$V_{ON} = 3\text{V}$	25		150	μA
Output Current Multiplication Ratio	OCMR	$I_{SET} = 25\mu\text{A}$, $V_{SAT} = 150\text{mV}$, $V_{ON} = 3\text{V}$	350	500	650	
Output Current Multiplication Ratio	OCMR	$I_{SET} = 40\mu\text{A}$, $V_{SAT} = 150\text{mV}$, $V_{ON} = 3\text{V}$	335	480	625	
Output Current Multiplication Ratio	OCMR	$I_{SET} = 75\mu\text{A}$, $V_{SAT} = 150\text{mV}$, $V_{ON} = 3\text{V}$	295	420	545	
Output Current Multiplication Ratio	OCMR	$I_{SET} = 25\mu\text{A}$, $V_{SAT} = 600\text{mV}$, $V_{ON} = 3\text{V}$	435	620	805	
Output Current Multiplication Ratio	OCMR	$I_{SET} = 40\mu\text{A}$, $V_{SAT} = 600\text{mV}$, $V_{ON} = 3\text{V}$	425	610	795	
Output Current Multiplication Ratio	OCMR	$I_{SET} = 75\mu\text{A}$, $V_{SAT} = 600\text{mV}$, $V_{ON} = 3\text{V}$	415	590	765	
Output Current Multiplication Ratio	OCMR	$I_{SET} = 25\mu\text{A}$, $V_{SAT} = 1000\text{mV}$, $V_{ON} = 3\text{V}$	470	670	870	
Output Current Multiplication Ratio	OCMR	$I_{SET} = 40\mu\text{A}$, $V_{SAT} = 1000\text{mV}$, $V_{ON} = 3\text{V}$	460	660	860	
Output Current Multiplication Ratio	OCMR	$I_{SET} = 75\mu\text{A}$, $V_{SAT} = 1000\text{mV}$, $V_{ON} = 3\text{V}$	440	630	820	
LED-to-LED Current Matching	Match	$V_{ON} = 3\text{V}$	-3		3	%
ISET in OFF Mode	$I_{SET,OFF}$	$V_{CTRL} = 3\text{V}$, $V_{SAT} = 3\text{V}$, $V_{ON} = 0\text{V}$		0.1	1	μA
IIN in OFF Mode	$I_{IN,OFF}$	$V_{CTRL} = 3\text{V}$, $V_{SAT} = 3\text{V}$, $V_{ON} = 0\text{V}$, $T_{AMB} = 25^{\circ}\text{C}$		0.1	1	μA
		$V_{CTRL} = 3\text{V}$, $V_{SAT} = 3\text{V}$, $V_{ON} = 0\text{V}$			4	
Peak Efficiency [†]	η	$V_{IN} = 3\text{V}$, $V_{ON} = 3\text{V}$	95			%

[†] Efficiency = $(V_{IN} - V_{SAT})/V_{IN}$. Information parameter, guaranteed by design.

AS1102, AS1103, AS1104 Electrical Characteristics

$T_{AMB} = 25^{\circ}\text{C}$ (unless otherwise noted).

Table 5. Electrical Characteristics – AS1102, AS1103, AS1104

Parameter	Symbol	Conditions	Min	Typ	Max	Units
ISET Range	ISET	$V_{ON} = 3\text{V}$	25		150	μA
Output Current Multiplication Ratio	OCMR	$I_{SET} = 25\mu\text{A}$, $V_{SAT} = 150\text{mV}$, $V_{ON} = 3\text{V}$	175	250	325	
Output Current Multiplication Ratio	OCMR	$I_{SET} = 40\mu\text{A}$, $V_{SAT} = 150\text{mV}$, $V_{ON} = 3\text{V}$	170	240	310	
Output Current Multiplication Ratio	OCMR	$I_{SET} = 75\mu\text{A}$, $V_{SAT} = 150\text{mV}$, $V_{ON} = 3\text{V}$	145	210	275	
Output Current Multiplication Ratio	OCMR	$I_{SET} = 25\mu\text{A}$, $V_{SAT} = 600\text{mV}$, $V_{ON} = 3\text{V}$	215	310	405	
Output Current Multiplication Ratio	OCMR	$I_{SET} = 40\mu\text{A}$, $V_{SAT} = 600\text{mV}$, $V_{ON} = 3\text{V}$	215	305	395	
Output Current Multiplication Ratio	OCMR	$I_{SET} = 75\mu\text{A}$, $V_{SAT} = 600\text{mV}$, $V_{ON} = 3\text{V}$	205	295	385	
Output Current Multiplication Ratio	OCMR	$I_{SET} = 25\mu\text{A}$, $V_{SAT} = 1000\text{mV}$, $V_{ON} = 3\text{V}$	235	335	435	
Output Current Multiplication Ratio	OCMR	$I_{SET} = 40\mu\text{A}$, $V_{SAT} = 1000\text{mV}$, $V_{ON} = 3\text{V}$	230	330	430	
Output Current Multiplication Ratio	OCMR	$I_{SET} = 75\mu\text{A}$, $V_{SAT} = 1000\text{mV}$, $V_{ON} = 3\text{V}$	220	315	410	

Table 5. Electrical Characteristics – AS1102, AS1103, AS1104

Parameter	Symbol	Conditions	Min	Typ	Max	Units
LED-to-LED Current Matching	Match	$V_{ON} = 3V$	-3		3	%
ISET in OFF Mode ¹	ISET,OFF	$V_{CTRL} = 3V, V_{SAT} = 3V, V_{ON} = 0V$		0.1	1	μA
IIN in OFF Mode ¹	IIN,OFF	$V_{CTRL} = 3V, V_{SAT} = 3V, V_{ON} = 0V,$ $T_{AMB} = 25^{\circ}C$		0.1	1	μA
		$V_{CTRL} = 3V, V_{SAT} = 3V, V_{ON} = 0V$			2	
Peak Efficiency ²	η	$V_{IN} = 3V, V_{ON} = 3V$	95			%

1. Not applicable to AS1103.

2. Efficiency = $(V_{IN} - V_{SAT}) / V_{IN}$. Information parameter, guaranteed by design.

7 Typical Performance Characteristics

Figure 3. Set Current vs. V_{CTRL}

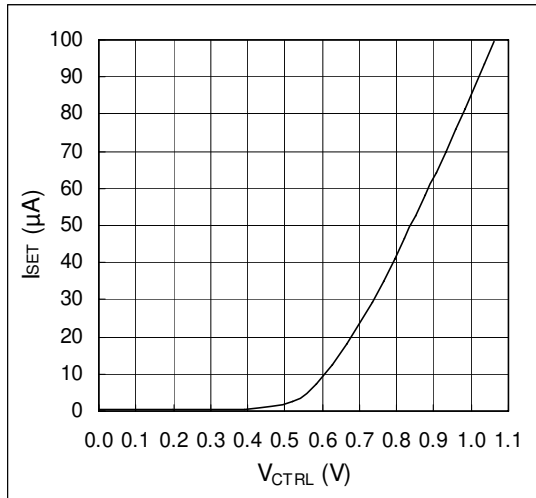

Figure 4. Set Current vs. V_{SET} ; $R_{SET} = 30k\Omega$

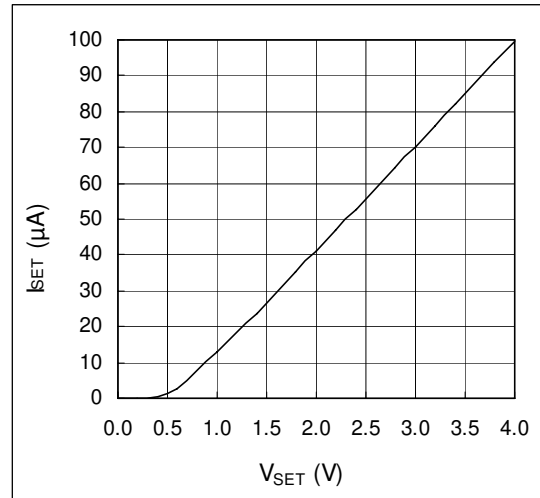

Figure 5. AS1101 I_{LED} vs. V_{SAT}

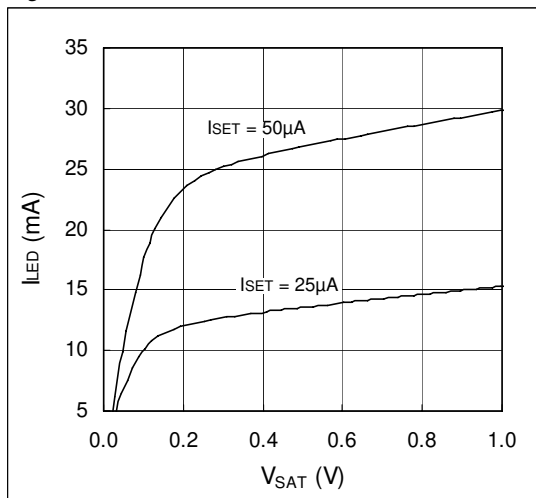

Figure 6. AS1102, AS1103, AS1104 I_{LED} vs. V_{SAT}

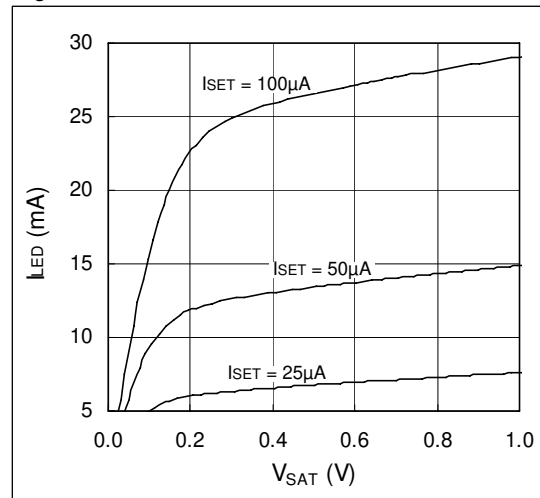

Figure 7. AS1101 OMCR vs. I_{SET}

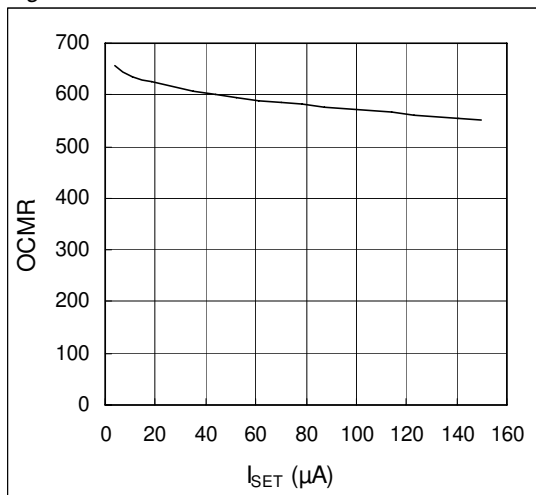

Figure 8. AS1102, AS1103, AS1104 OMCR vs. I_{SET}

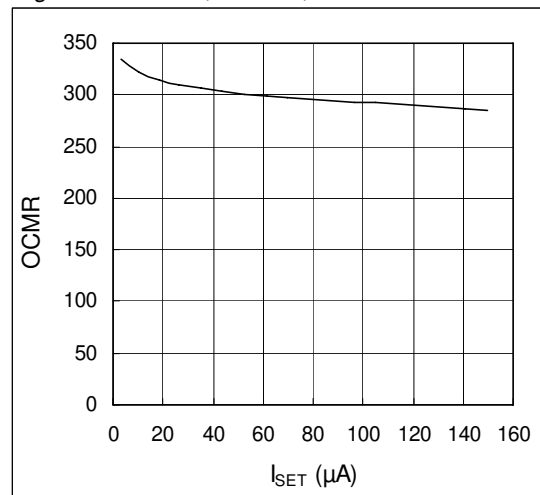

Figure 9. AS1102, AS1103, AS1104 ILED vs. RSET; VSET = 3V

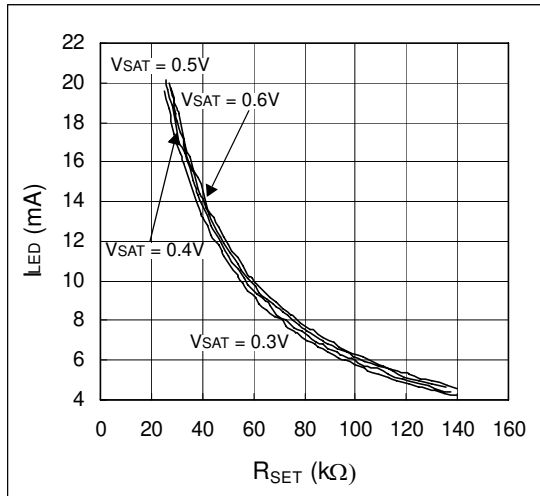

Figure 10. AS1102, AS1103, AS1104 ILED vs. RSET; VSET = 3V

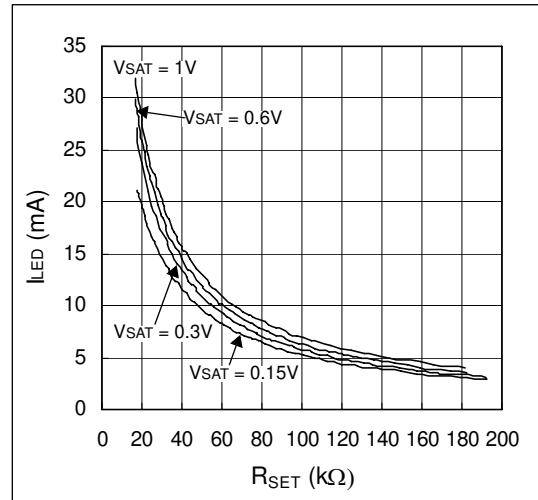

Figure 11. AS1101 ILED vs. RSET; VSET = 3V

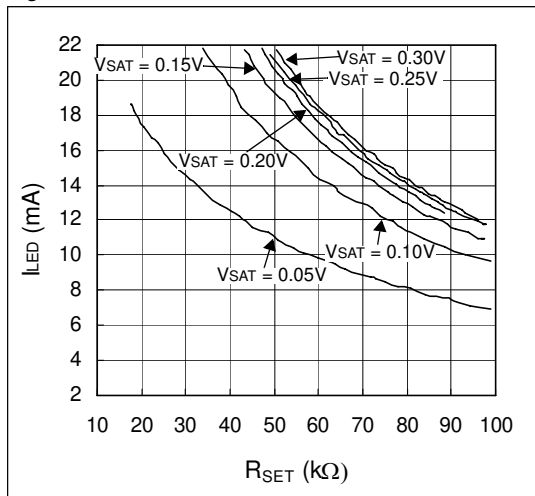

Figure 12. ILED vs. Temp; VLED = -0.25V, ISET = 50μA

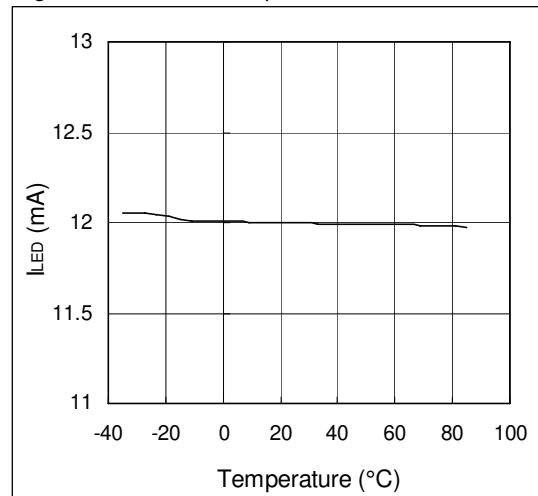

Figure 13. AS1101 ILED vs. ISET

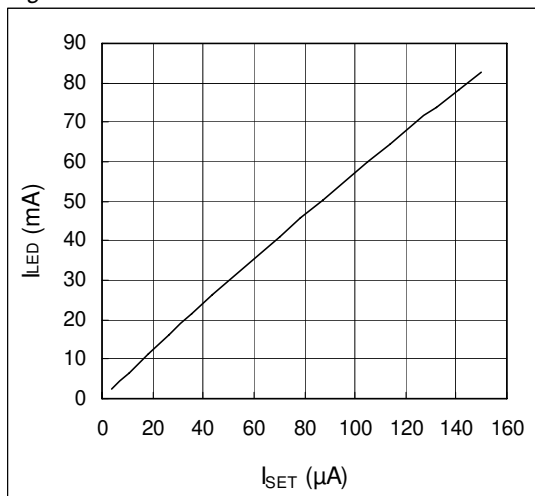

Figure 14. AS1102, AS1103, AS1104 ILED vs. ISET

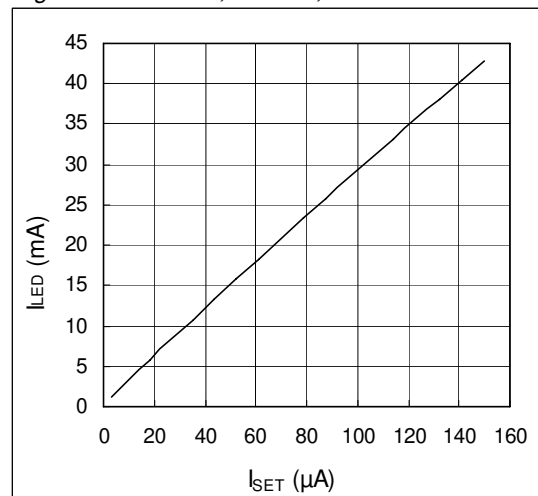

Figure 15. AS1101 vs. RSET

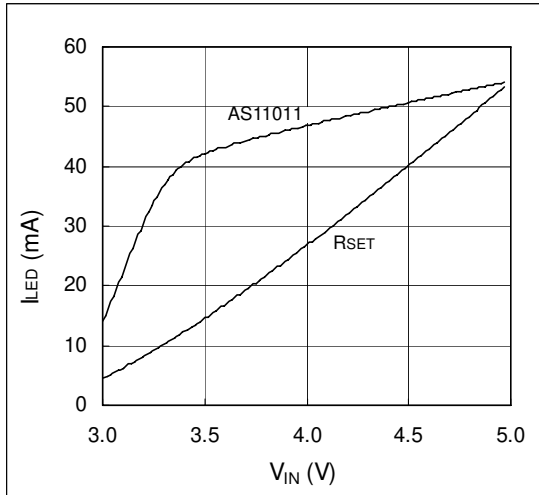

Figure 16. AS1102, AS1103, AS1104 I_{LED} vs. V_{IN}

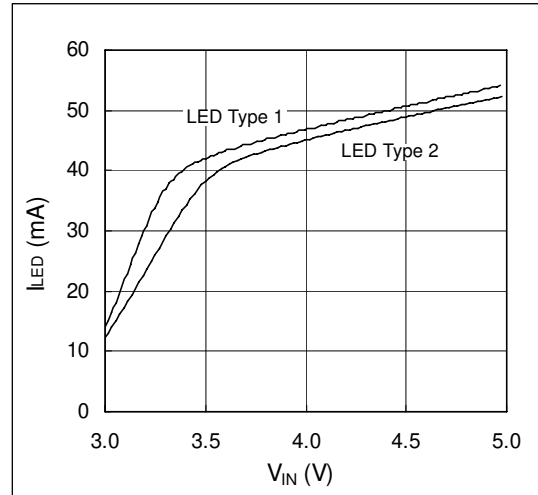

Figure 17. Control Voltage Transient Response

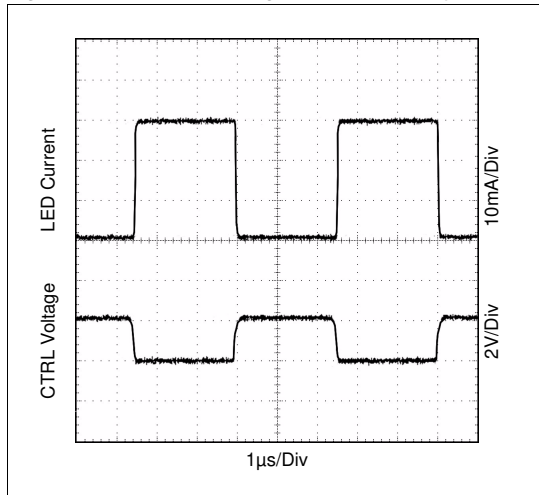
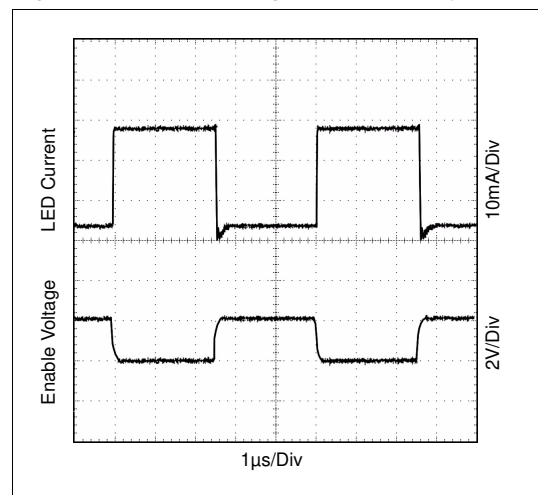
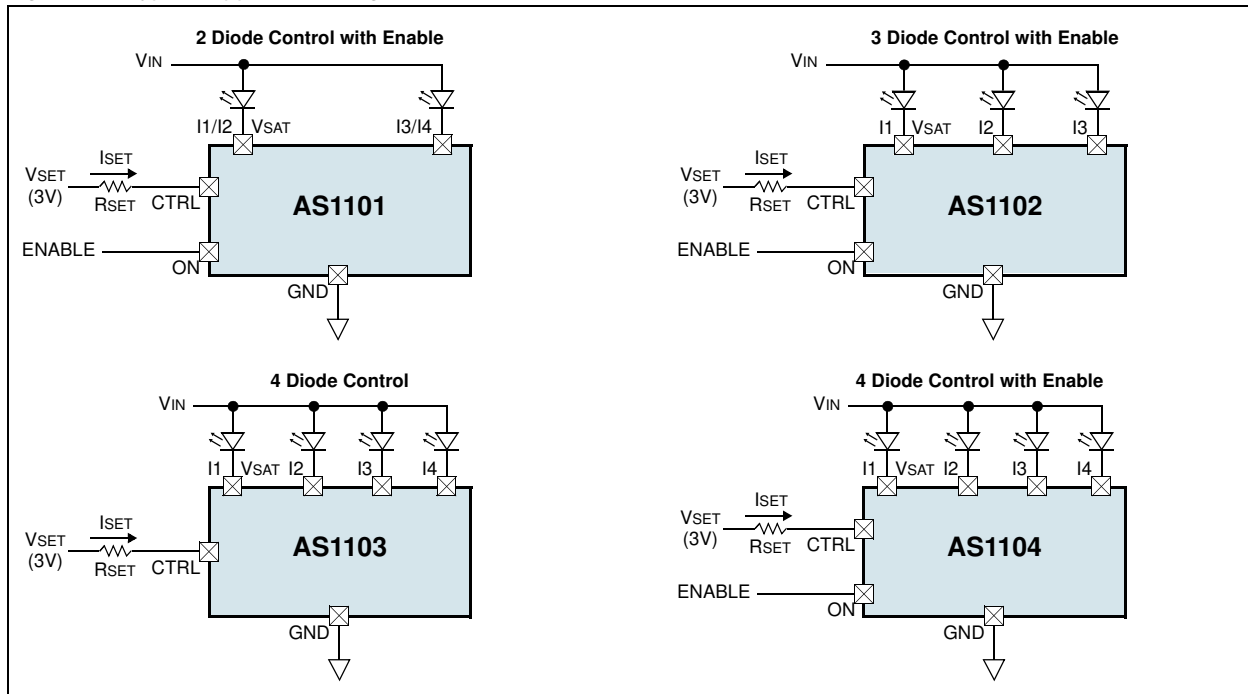

Figure 18. Enable Voltage Transient Response



8 Application Information

Figure 19. Typical Application Diagrams



Setting the LED Current

The current going into the LEDs is approximately OCMR times greater than the current ISET. LED current is controlled by VSET and RSET (see Figure 19) according to the formula:

$$I_{LED} = OCMR \times (V_{SET} - V_{CTRL}) / R_{SET} \quad (EQ 1)$$

For VSET = 3V and a specific LED current, the value of RSET can be determined using the graphs shown in Figure 9, Figure 10, and Figure 11 on page 7. For any other option, the value of ISET can be determined using the graph in Figure 3 on page 6.

Note: LED brightness can also be adjusted by driving pin ENABLE or pin CTRL with a PWM signal.

9 Package Drawings and Markings

Figure 20. SC70-6 Package

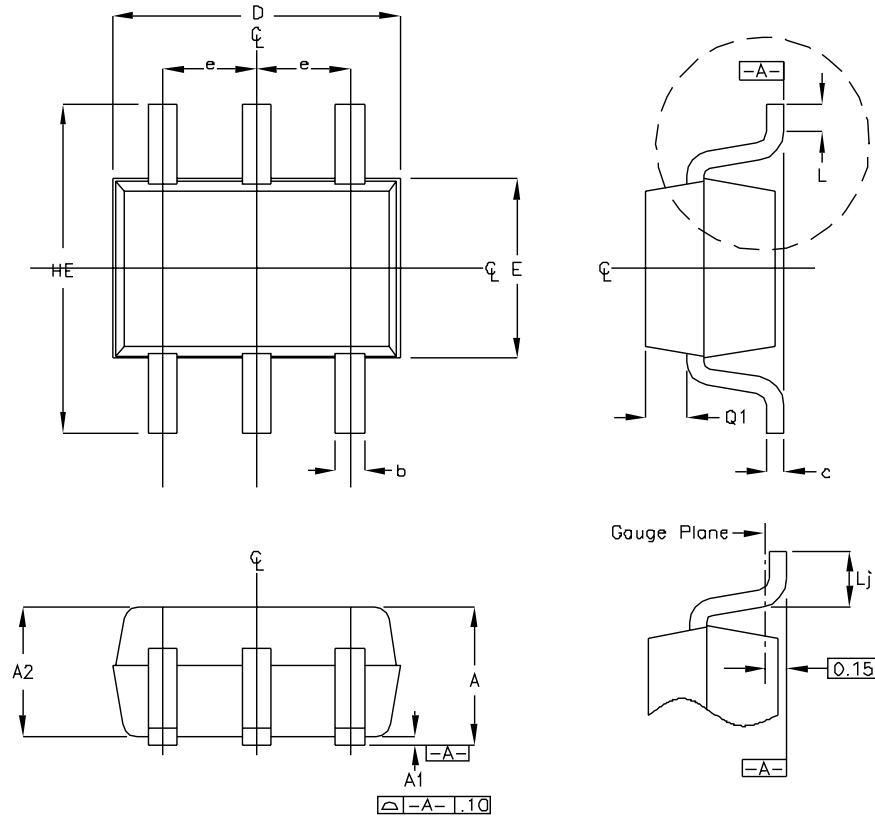

Notes:

1. All dimensions are in millimeters.
2. Dimensions are inclusive of plating.
3. Dimensions are exclusive of mold flash and metal burrs.
4. All specifications comply with JEITA SC88 and JEDEC-MO-203.

Symbol	Min	Max
e	0.65 BSC	
D	1.80	2.20
b	0.15	0.30
E	1.15	1.35
HE	1.80	2.40
Q1	0.10	0.40
A2	0.80	1.00
A1	0.00	0.10
A	0.80	1.10
c	0.10	0.18
L	0.10	0.30
Lj	0.26	0.46

Figure 21. MSOP-8 Package

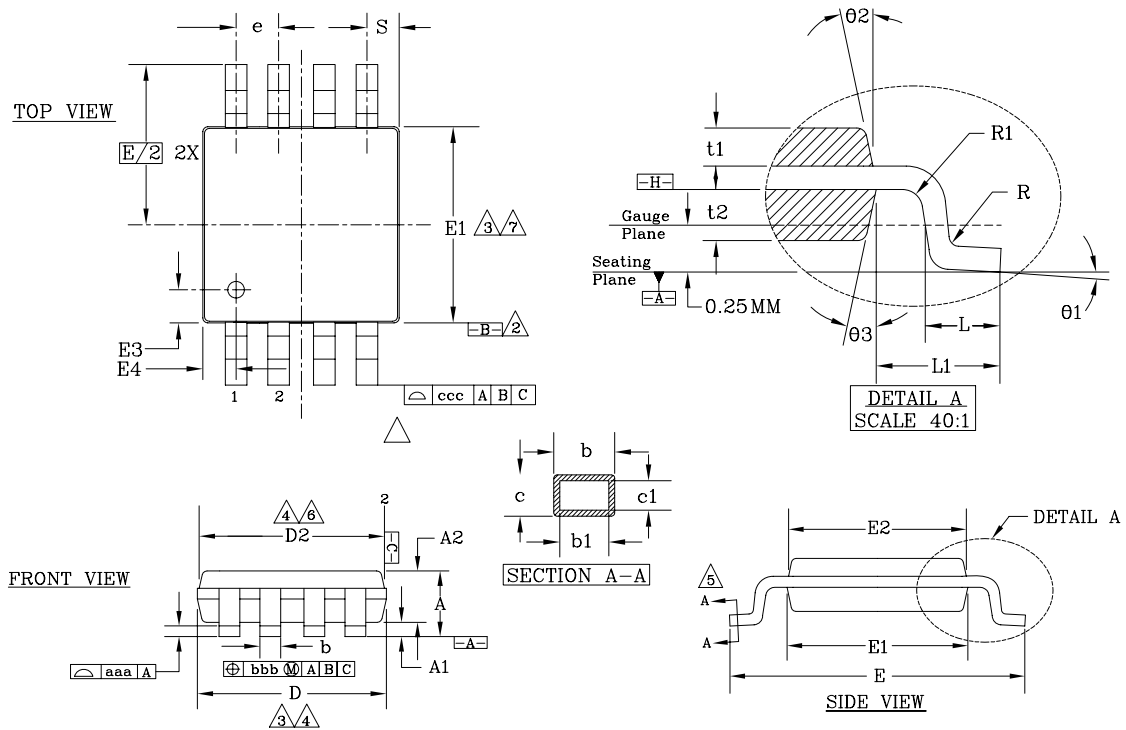

Symbol	Millimeters	± Tolerance	Symbol	Millimeters	± Tolerance
A	1.10	Max	b	0.33	+0.07 to -0.08
A1	0.10	±0.05	b1	0.30	±0.05
A2	0.86	±0.08	c	0.18	±0.05
D	3.00	±0.10	c1	0.15	+0.03 to -0.02
D2	2.95	±0.10	θ1	3.0°	±3.0°
E	4.90	±0.15	θ2	12.0°	±3.0°
E1	3.00	±0.10	θ3	12.0°	±3.0°
E2	2.95	±0.10	L	0.55	±0.15
E3	0.51	±0.13	L1	0.95 BSC	
E4	0.51	±0.13	aaa	0.10	
R	0.15	+0.15 to -0.08	bbb	0.08	
R1	0.15	+0.15 to -0.08	ccc	0.25	
t1	0.31	±0.08	e	.65 BSC	
t2	0.41	±0.08	S	.525 BSC	

Notes:

1. All dimensions are in millimeters (angle in degrees), unless otherwise specified.
2. Datums B and C to be determined at datum plane H.
3. Dimensions D and E1 are to be determined at datum plane H.
4. Dimensions D2 and E2 are for top package and D and E1 are for bottom package.
5. Cross section A-A to be determined at 0.13 to 0.25mm from the lead tip.
6. Dimensions D and D2 do not include mold flash, protrusion, or gate burrs.
7. Dimension E1 and E2 do not include interlead flash or protrusion.

10 Ordering Information

Part Number	Marking	Description	Package Type	Delivery Form
AS1101-T	JO1	Dual LED driver with enable.	SC70-6	Tape and Reel
AS1102-T	JO2	Triple LED driver with enable.		
AS1103-T	JO3	Quad LED driver.		
AS1104-T	JO4	Quad LED driver with enable.	MSOP-8	Tape and Reel
AS1104				Tubes

Copyrights

Copyright © 1997-2007, austriamicrosystems AG, Schloss Premstaetten, 8141 Unterpremstaetten, Austria-Europe. Trademarks Registered ®. All rights reserved. The material herein may not be reproduced, adapted, merged, translated, stored, or used without the prior written consent of the copyright owner.

All products and companies mentioned are trademarks or registered trademarks of their respective companies.

Disclaimer

Devices sold by austriamicrosystems AG are covered by the warranty and patent indemnification provisions appearing in its Term of Sale. austriamicrosystems AG makes no warranty, express, statutory, implied, or by description regarding the information set forth herein or regarding the freedom of the described devices from patent infringement. austriamicrosystems AG reserves the right to change specifications and prices at any time and without notice. Therefore, prior to designing this product into a system, it is necessary to check with austriamicrosystems AG for current information. This product is intended for use in normal commercial applications. Applications requiring extended temperature range, unusual environmental requirements, or high reliability applications, such as military, medical life-support or life-sustaining equipment are specifically not recommended without additional processing by austriamicrosystems AG for each application. For shipments of less than 100 parts the manufacturing flow might show deviations from the standard production flow, such as test flow or test location.

The information furnished here by austriamicrosystems AG is believed to be correct and accurate. However, austriamicrosystems AG shall not be liable to recipient or any third party for any damages, including but not limited to personal injury, property damage, loss of profits, loss of use, interruption of business or indirect, special, incidental or consequential damages, of any kind, in connection with or arising out of the furnishing, performance or use of the technical data herein. No obligation or liability to recipient or any third party shall arise or flow out of austriamicrosystems AG rendering of technical or other services.



Contact Information

Headquarters

austriamicrosystems AG
A-8141 Schloss Premstaetten, Austria

Tel: +43 (0) 3136 500 0
Fax: +43 (0) 3136 525 01

For Sales Offices, Distributors and Representatives, please visit:

<http://www.austriamicrosystems.com/contact>