



Chipsmall Limited consists of a professional team with an average of over 10 year of expertise in the distribution of electronic components. Based in Hongkong, we have already established firm and mutual-benefit business relationships with customers from,Europe,America and south Asia,supplying obsolete and hard-to-find components to meet their specific needs.

With the principle of “Quality Parts,Customers Priority,Honest Operation,and Considerate Service”,our business mainly focus on the distribution of electronic components. Line cards we deal with include Microchip,ALPS,ROHM,Xilinx,Pulse,ON,Everlight and Freescale. Main products comprise IC,Modules,Potentiometer,IC Socket,Relay,Connector.Our parts cover such applications as commercial,industrial, and automotives areas.

We are looking forward to setting up business relationship with you and hope to provide you with the best service and solution. Let us make a better world for our industry!



Contact us

Tel: +86-755-8981 8866 Fax: +86-755-8427 6832

Email & Skype: info@chipsmall.com Web: www.chipsmall.com

Address: A1208, Overseas Decoration Building, #122 Zhenhua RD., Futian, Shenzhen, China





Eval Kit Manual

AS1111A

Standard Board

AS1111A-WL_EK_ST

Content Guide

1	Introduction	3
2	Kit Content	3
3	Getting Started	3
4	Hardware Description.....	4
5	Schematics, Layers and BOM	6
5.1	Schematic of AS1111A Evaluation Board.....	6
5.2	Layers	7
5.3	Bill of Materials.....	8
6	Ordering & Contact Information	9
7	Copyrights & Disclaimer.....	10
8	Revision Information	10

1 Introduction

This document describes the AS1111A Evaluation Kit.

The AS1111A is a LED driver designed to match current source bias for any color LED, including white and blue. The devices can drive up to 2 high-current LEDs, and the LED current is programmable using an external resistor (RSET).

The AS1111A LED currents are $460 \times I_{SET}$ (per LED, type) at an LED cathode voltage (VSAT) of 150mV and $650 \times I_{SET}$ (type) at a VSAT of 1V, where ISET is the current through RSET connected to pin CTRL.

The AS1111A incorporate a chip-enable feature via pin EN. When the devices is disabled, the supply current drops down to less than 1µA. The AS1111A are available in a 6-pin WL-CSP package with 0.4mm pitch.

2 Kit Content

Figure 1: Kit Content

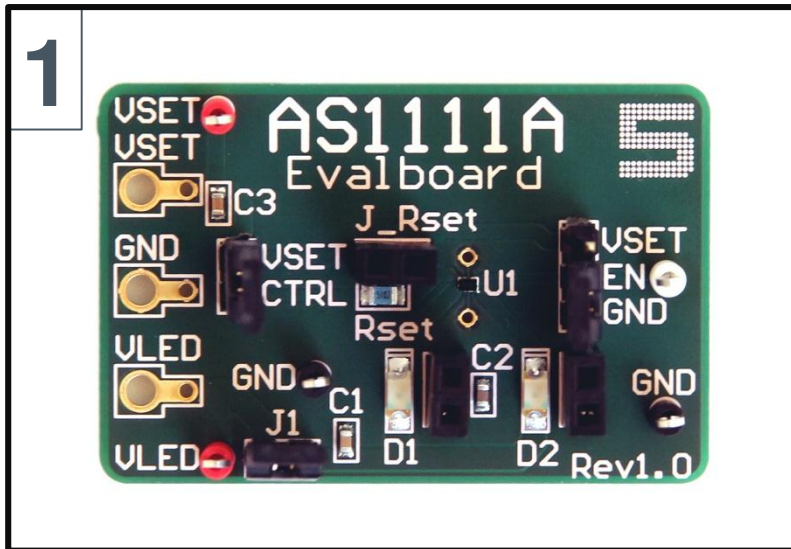

Label	Item	Comment
1	Evaluation Board	AS1111A (6-pin WL-CSP package with 0.4mm pitch)

3 Getting Started

Connect your supply to GND, VSET and VLED. Be shure that the jumpers are set like you can see in the Hardware Description below.

4 Hardware Description

Figure 2: Evaluation Board Overview

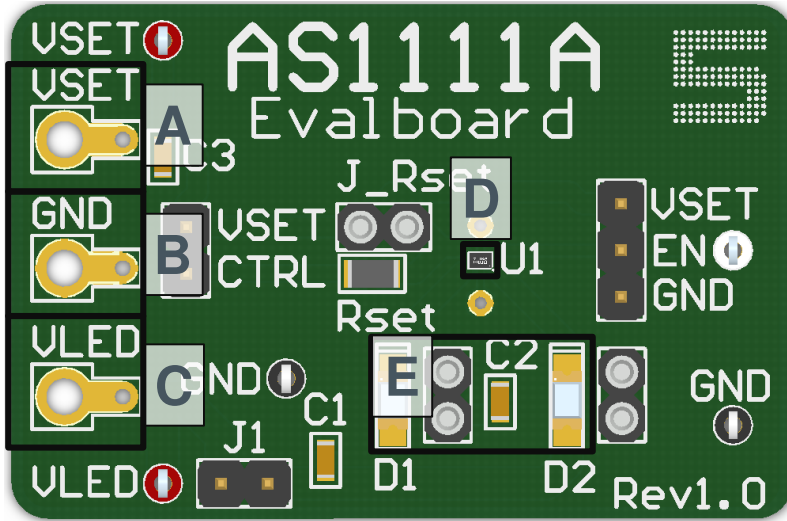

Label	Name	Designator	Description	Info
A	VSET	VSET	Voltage	Voltage to set the LED Current
B	GND	GND	Ground	
C	VLED	VLED	LED Supply	Supply Voltage for the LED's
D	AS1111A	U1	LED – driver	
E	LED's	D1, D2		

Figure 3: Jumper and device locations

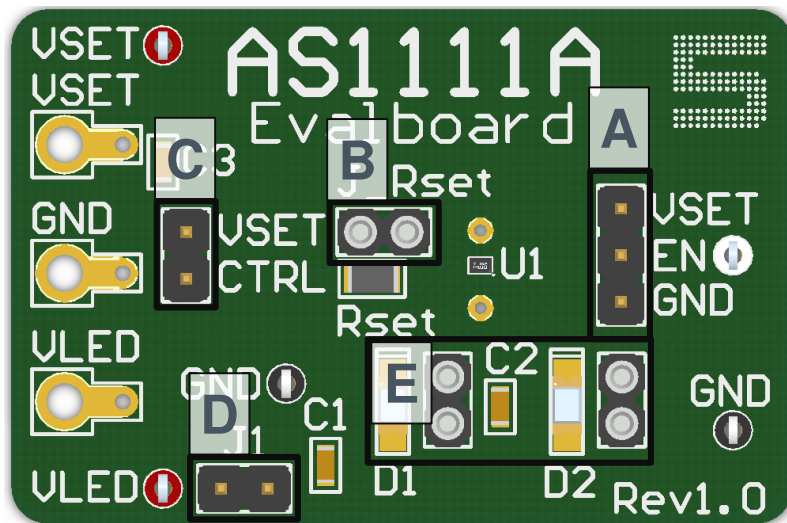



Label	Name	Designator	Description	Info
A	J_EN	J_EN	Enable or Disable the LED – driver	 GND - disabled  VSET - enabled
B	RSET	J_Rset		Connect different kind of RSET or you can make a parallel connection. Depending on Jumper J_CTRL.
C	J_CTRL	J_CTRL		Connect / Disconnect the soldered (51k) RSET resistor
D	J1	J1	Jumper	Connect / Disconnect LED's
E	LED's	J_D1, J_D2	Female Header	Connect different kind of LED's

Figure 4: Measurement Points



Label	Name	Designator	Description	Info
A	VSET	VSET	Voltage to set the LED current	Measurement Point
B	LED Voltage	VLED	Supply Voltage for the LED's	Measurement Point
C	GND	GND	Ground	Measurement Point
D	Enable	EN	$V_{EN} \geq 2.2V$: VOUT is enabled $V_{EN} \leq 0.5V$: VOUT is disabled	Measurement Point
E	GND	GND	Ground	Measurement Point

5 Schematics, Layers and BOM

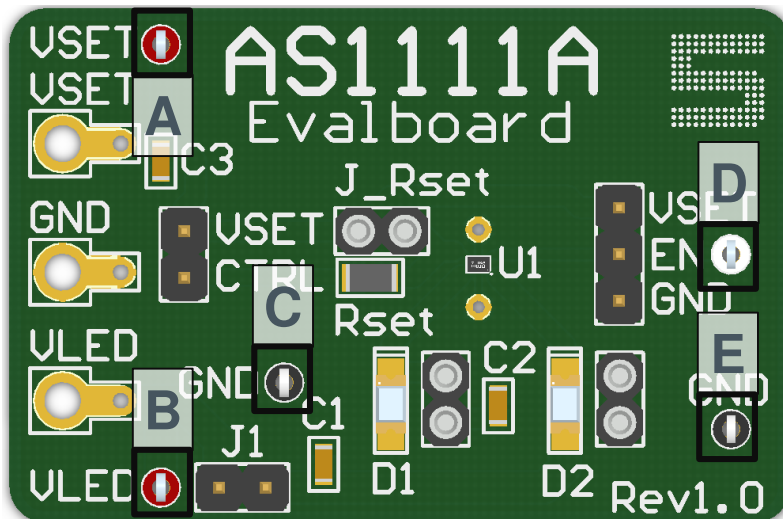
5.1 Schematic of AS1111A Evaluation Board

Figure 5: Schematic

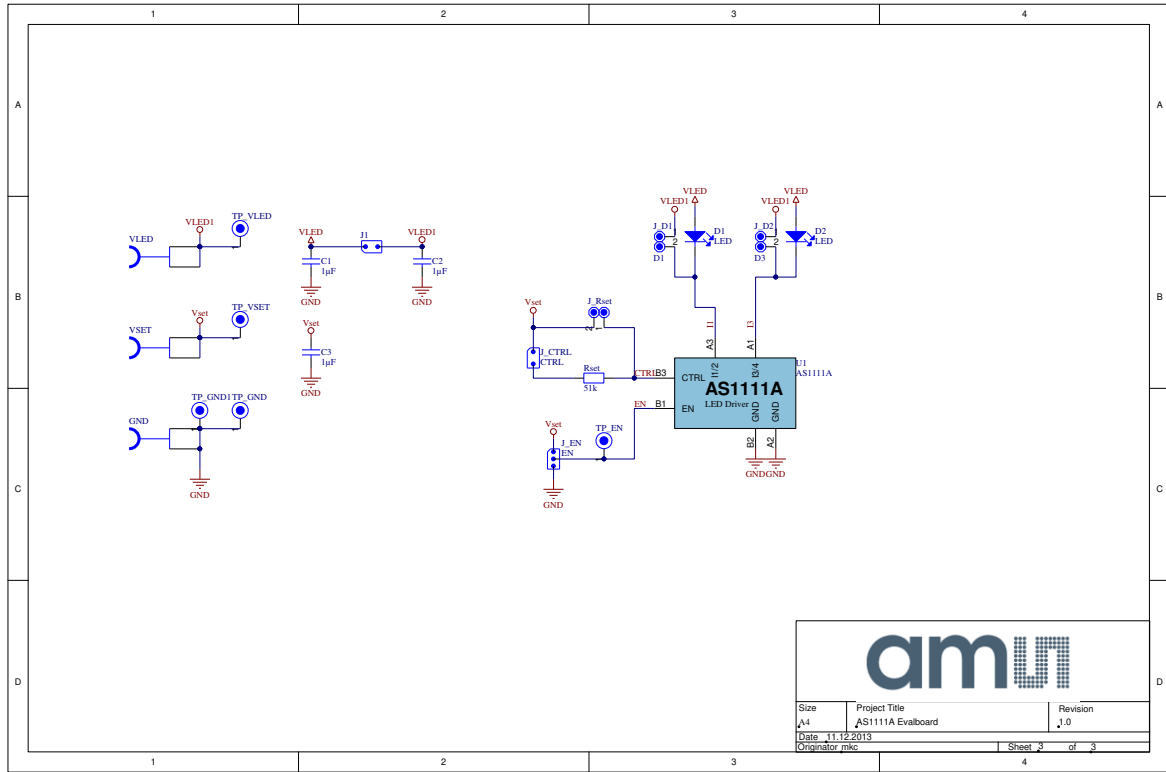

5.2 Layers

Figure 6: Top Layer

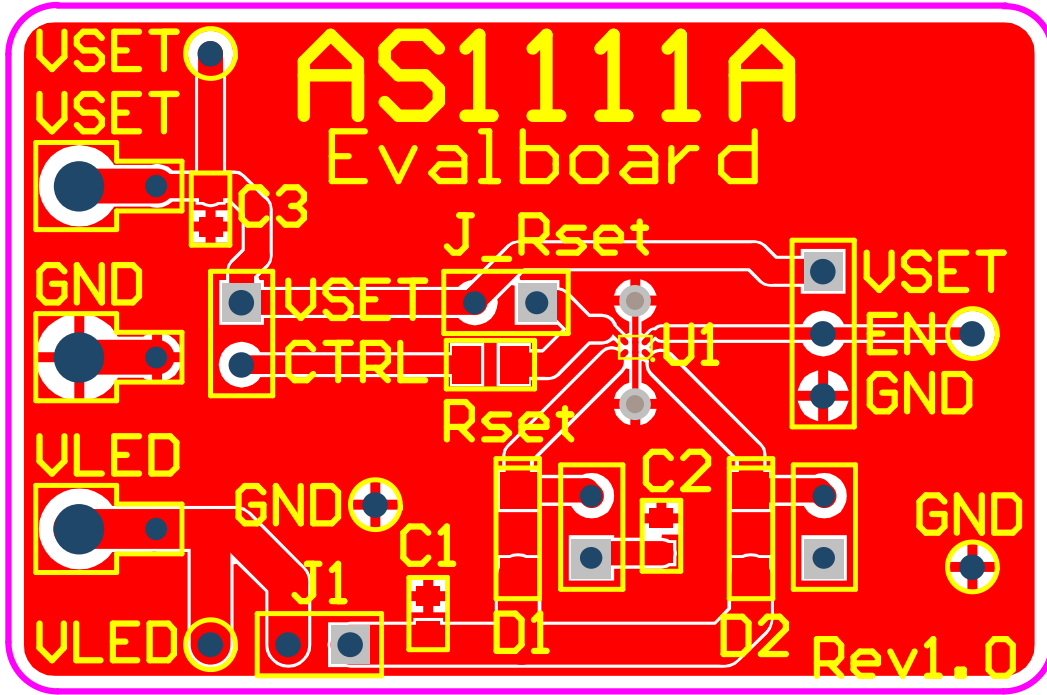
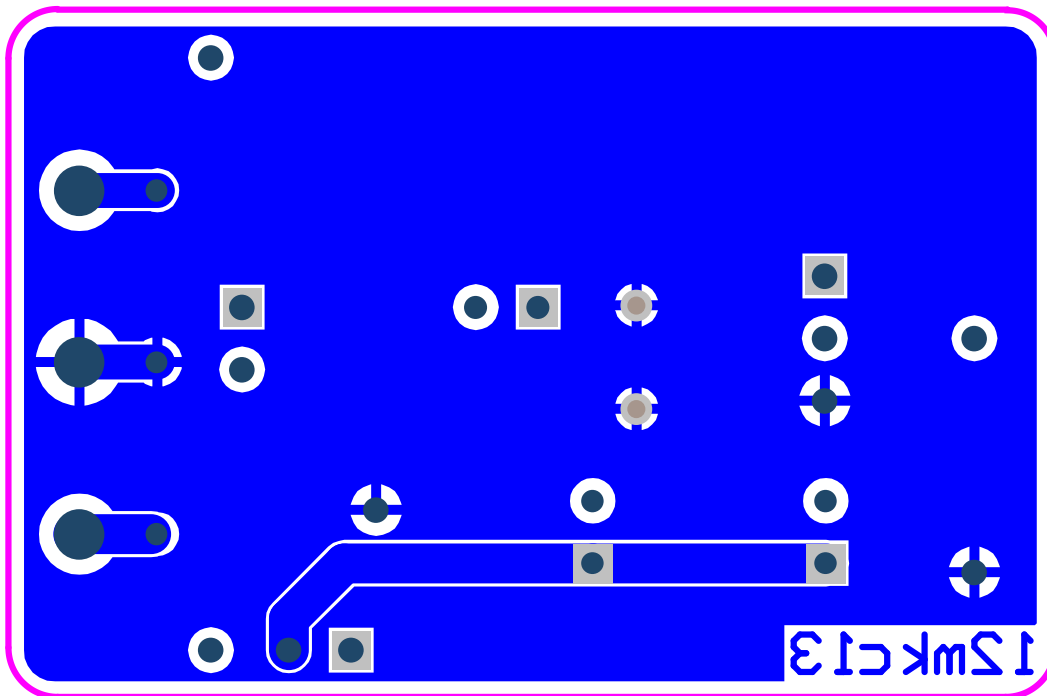

Figure 7: Bottom Layer



5.3 Bill of Materials

Figure 8: BOM

Bill of Materials			AS1111A Evalboard			
Company:		ams AG				
Originator:		mkc				
PCB Name:		AS1111A Evalboard				
PCB Version:		1.0				
Report Date:		11.12.2013				
#	Designator	Comment	Component_Description	Manufacturer	Manufacturer Part Number	Quantity
1	C1, C2, C3	1µF	CAP CER 1UF 16V 20% X5R 0603	Murata Electronics North America	GRM188R61C105MA12D	3
2	D1, D2	LED	LED 3.2X1.6MM 630NM RED CLR SMD	Kingbright	APT3216SURCK	2
3	J1, J_CTRL	2 PIN, CTRL	3M - 961102-6404-AR - CONNECTOR, HEADER, 2POS, 1ROW, 2.54MM	3M	961102-6404-AR	2
4	J_D1, J_D2, J_Rset	D1, D3	SAMTEC - SSA-102-S-G - BUCHSE, 2.54MM, LPT, 2KONT	SAMTEC	SSA-102-S-G	3
5	J_EN	EN	3M - 961103-6404-AR - BOARD TO BOARD, HEADER, 3POS, 1ROW	3M	961103-6404-AR	1
6	Rset	51k	MULTICOMP - MCO1W0805151K - WIDERSTAND, 51K, 0.1W, 1%, 0805	MULTICOMP	MCO1W0805151K	1
7	TP_EN	Testpoint	VERO - 20-313139 - PRÜFPUNKT, PCB, WEISS, PK100	VERO	20-313139	1
8	TP_GND, TP_GND1	Testpoint	VERO - 20-2137 - PRÜFPUNKT, PCB, SCHWARZ, PK100	VERO	20-2137	2
9	TP_VLED, TP_VSET	Testpoint	VERO - 20-313137 - PRÜFPUNKT, PCB, ROT, PK100	VERO	20-313137	2
10	UI	AS1111A			AS1111A-WL_BK_ST	1
Approved			Notes			16

6 Ordering & Contact Information

Ordering Code	Description
AS1111A-WL_EK_ST	AS1111A Eval Kit Standard Board

Buy our products or get free samples online at:

www.ams.com/ICdirect

Technical Support is available at:

www.ams.com/Technical-Support

Provide feedback about this document at:

www.ams.com/Document-Feedback

For further information and requests, e-mail us at:

ams_sales@ams.com

For sales offices, distributors and representatives, please visit:

www.ams.com/contact

Headquarters

ams AG

Tobelbaderstrasse 30

8141 Unterpremstaetten

Austria, Europe

Tel: +43 (0) 3136 500 0

Website: www.ams.com

7 Copyrights & Disclaimer

Copyright ams AG, Tobelbader Strasse 30, 8141 Unterpremstaetten, Austria-Europe. Trademarks Registered. All rights reserved. The material herein may not be reproduced, adapted, merged, translated, stored, or used without the prior written consent of the copyright owner.

Demo Kits, Evaluation Kits and Reference Designs are provided to recipient on an “as is” basis for demonstration and evaluation purposes only and are not considered to be finished end-products intended and fit for general consumer use, commercial applications and applications with special requirements such as but not limited to medical equipment or automotive applications. Demo Kits, Evaluation Kits and Reference Designs have not been tested for compliance with electromagnetic compatibility (EMC) standards and directives, unless otherwise specified. Demo Kits, Evaluation Kits and Reference Designs shall be used by qualified personnel only.

ams AG reserves the right to change functionality and price of Demo Kits, Evaluation Kits and Reference Designs at any time and without notice.

Any express or implied warranties, including, but not limited to the implied warranties of merchantability and fitness for a particular purpose are disclaimed. Any claims and demands and any direct, indirect, incidental, special, exemplary or consequential damages arising from the inadequacy of the provided Demo Kits, Evaluation Kits and Reference Designs or incurred losses of any kind (e.g. loss of use, data or profits or business interruption however caused) as a consequence of their use are excluded.

ams AG shall not be liable to recipient or any third party for any damages, including but not limited to personal injury, property damage, loss of profits, loss of use, interruption of business or indirect, special, incidental or consequential damages, of any kind, in connection with or arising out of the furnishing, performance or use of the technical data herein. No obligation or liability to recipient or any third party shall arise or flow out of ams AG rendering of technical or other services.

8 Revision Information

Initial version 1-00