



Chipsmall Limited consists of a professional team with an average of over 10 year of expertise in the distribution of electronic components. Based in Hongkong, we have already established firm and mutual-benefit business relationships with customers from,Europe,America and south Asia,supplying obsolete and hard-to-find components to meet their specific needs.

With the principle of “Quality Parts,Customers Priority,Honest Operation,and Considerate Service”,our business mainly focus on the distribution of electronic components. Line cards we deal with include Microchip,ALPS,ROHM,Xilinx,Pulse,ON,Everlight and Freescale. Main products comprise IC,Modules,Potentiometer,IC Socket,Relay,Connector.Our parts cover such applications as commercial,industrial, and automotives areas.

We are looking forward to setting up business relationship with you and hope to provide you with the best service and solution. Let us make a better world for our industry!



Contact us

Tel: +86-755-8981 8866 Fax: +86-755-8427 6832

Email & Skype: info@chipsmall.com Web: www.chipsmall.com

Address: A1208, Overseas Decoration Building, #122 Zhenhua RD., Futian, Shenzhen, China



AS1310

Ultra Low Quiescent Current, Hysteretic DC-DC Step-Up Converter

General Description

The AS1310 is an ultra low quiescent current hysteretic step-up DC-DC converter optimized for light loads (60mA), where it achieves efficiencies of up to 92%.

AS1310 operates from a 0.7V to 3.6V supply and supports output voltages between 1.8V and 3.3V. Besides the available AS1310 standard variants any variant with output voltages in 50mV steps are available.

If the input voltage exceeds the output voltage the device is in a feed-through mode and the input is directly connected to the output voltage.

In light load operation, the device enters a sleep mode when most of the internal operating blocks are turned OFF in order to save power. This mode is active approximately 50 μ s after a current pulse provided that the output is in regulation.

In order to save power the AS1310 features a shutdown mode, where it draws less than 100nA. During shutdown mode the battery is disconnected from the output.

The AS1310 also offers adjustable low battery detection. If the battery voltage decreases below the threshold defined by two external resistors on pin LBI, the LBO output is pulled to logic low.

The AS1310 is available in a TDFN (2x2) 8-pin package.

[Ordering Information](#) and [Content Guide](#) appear at end of datasheet.

Key Benefits & Features

The benefits and features of AS1310, Ultra Low Quiescent Current, Hysteretic DC-DC Step-Up Converter are listed below:

Figure 1:
Added Value of Using AS1310

Benefits	Features
Ideal for single Li-Ion battery powered applications	<ul style="list-style-type: none"> Wide Input Voltage Range (0.7V to 3.6V) Feed through mode when $V_{IN} > V_{OUT}$
Extended battery life	<ul style="list-style-type: none"> High Efficiency up to 92% Low Quiescent Current of typ. 1μA Low Shutdown Current of less than 100nA
Supports a variety of end applications	<ul style="list-style-type: none"> Fixed output voltage range (1.8V to 3.3V) Output Disconnect in shutdown Output current: 60mA @ $V_{IN}=0.9V, V_{OUT}=1.8V$

Benefits	Features
Over – temperature protection and shutdown	Integrated temperature monitoring
Early power-fail warning	Adjustable low battery detection
Cost effective, small package	<ul style="list-style-type: none"> No external diode or transistor required 8-pin TDFN (2mm x 2mm)

Applications

The AS1310 is an ideal solution for single and dual cell powered devices as blood glucose meters, remote controls, hearing aids, wireless mouse or any light-load application.

Figure 2:
Typical Application Diagram

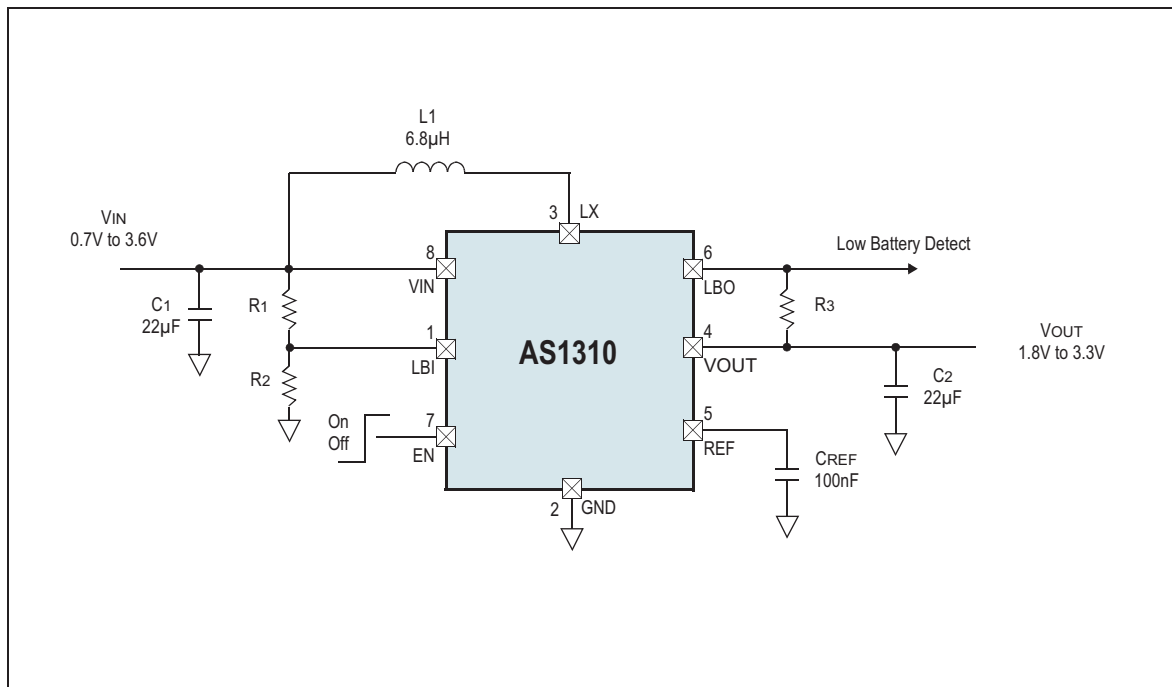

Pin Assignment

Figure 3:
Pin Diagram (Top View)

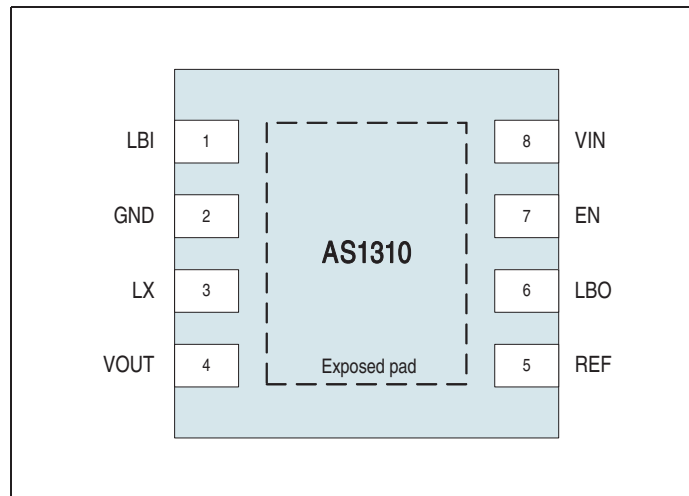

Figure 4:
Pin Description

Pin Number	Pin Name	Description
1	LBI	Low Battery Comparator Input. 0.6V Threshold. May not be left floating. If connected to GND, LBO is working as Power Output OK.
2	GND	Ground
3	LX	External Inductor Connector
4	V_{OUT}	Output Voltage. Decouple V_{OUT} with a ceramic capacitor as close as possible to V_{OUT} and GND .
5	REF	Reference Pin. Connect a 100nF ceramic capacitor to this pin.
6	LBO	Low Battery Comparator Output. Open-drain output.
7	EN	Enable Pin. Logic controlled shutdown input. 1 = Normal operation; 0 = Shutdown; shutdown current <100nA.
8	V_{IN}	Battery Voltage Input. Decouple V_{IN} with a 22 μ F ceramic capacitor as close as possible to V_{IN} and GND .
9	NC	Exposed Pad. This pad is not connected internally. Can be left floating or connect to GND to achieve an optimal thermal performance.

Absolute Maximum Ratings

Stresses beyond those listed in Absolute Maximum Ratings may cause permanent damage to the device. These are stress ratings only, and functional operation of the device at these or any other conditions beyond those indicated in Electrical Characteristics is not implied. Exposure to absolute maximum rating conditions for extended periods may affect device reliability.

Figure 5:
Absolute Maximum Ratings

Parameter	Min	Max	Units	Comments
Electrical Parameters				
V_{IN} , V_{OUT} , EN, LBI, LBO to GND	-0.3	+5	V	
LX, REF to GND	-0.3	$V_{OUT} + 0.3$	V	
Input Current (latch-up immunity)	-100	100	mA	Norm: JEDEC 78
Electrostatic Discharge				
Electrostatic Discharge HBM	± 2		kV	Norm: MIL 883 E method 3015
Temperature Ranges and Storage Conditions				
Thermal Resistance θ_{JA}	58		$^{\circ}\text{C}/\text{W}$	
Junction Temperature		+125	$^{\circ}\text{C}$	
Storage Temperature Range	-55	+125	$^{\circ}\text{C}$	
Package Body Temperature		+260	$^{\circ}\text{C}$	The reflow peak soldering temperature (body temperature) specified is in accordance with <i>IPC/JEDEC J-STD-020 "Moisture/Reflow Sensitivity Classification for Non-Hermetic Solid State Surface Mount Devices"</i> . The lead finish for Pb-free leaded packages is matte tin (100% Sn).
Humidity non-condensing	5	85	%	
Moisture Sensitive Level	1			Represents a maximum floor life time of unlimited

Electrical Characteristics

All limits are guaranteed. The parameters with Min and Max values are guaranteed by production tests or SQC (Statistical Quality Control) methods.

$V_{IN} = 1.5V$, $C1 = C2 = 22\mu F$, $C_{REF} = 100nF$, Typical values are at $T_{AMB} = +25^{\circ}C$ (unless otherwise specified). All limits are guaranteed. The parameters with min and max values are guaranteed with production tests or SQC (Statistical Quality Control) methods.

Figure 6:
Electrical Characteristics

Symbol	Parameter	Conditions	Min	Typ	Max	Units
T_{AMB}	Operating Temperature Range		-40		+85	$^{\circ}C$
Input						
V_{IN}	Input Voltage Range		0.7		3.6	V
	Minimum Startup Voltage	$I_{LOAD} = 1mA$, $T_{AMB} = +25^{\circ}C$		0.7	0.8	V
Regulation						
V_{OUT}	Output Voltage Range		1.8		3.3	V
	Output Voltage Tolerance	$I_{LOAD} = 10mA$, $T_{AMB} = +25^{\circ}C$	-2		+2	%
		$I_{LOAD} = 10mA$	-3		+3	%
	V_{OUT} Lockout Threshold ⁽¹⁾	Rising Edge	1.55	1.65	1.75	V
Operating Current						
I_Q	Quiescent Current V_{IN}	$V_{OUT} = 1.02 \times V_{OUTNOM}$, REF = $0.99 \times V_{OUTNOM}$, $T_{AMB} = +25^{\circ}C$			100	nA
	Quiescent Current V_{OUT}	$V_{OUT} = 1.02 \times V_{ON}$, REF = $0.99 \times V_{ON}$, No load, $T_{AMB} = +25^{\circ}C$	0.8	1	1.2	μA
I_{SHDN}	Shutdown Current	$T_{AMB} = +25^{\circ}C$			100	nA

Symbol	Parameter	Conditions	Min	Typ	Max	Units
Switches						
R_{ON}	NMOS	$V_{OUT} = 3V$		0.35		Ω
	PMOS			0.5		Ω
	NMOS maximum On-time		3.6	4.2	4.8	μs
I_{PEAK}	Peak Current Limit		320	400	480	mA
	Zero Crossing Current		5	20	35	mA
Enable, Reference						
V_{ENH}	EN Input Voltage High		0.7			V
V_{ENL}	EN Input Voltage Low				0.1	V
I_{EN}	EN Input Bias Current	$EN = 3.6V, T_{AMB} = +25^{\circ}C$			100	nA
I_{REF}	REF Input Bias Current	$REF = 0.99 \times V_{OUTNOM}, T_{AMB} = +25^{\circ}C$			100	nA
Low Battery & Power-OK						
V_{LBI}	LBI Threshold	Falling Edge	0.57	0.6	0.63	V
	LBI Hysteresis			25		mV
I_{LBI}	LBI Leakage Current	$LBI = 3.6V, T_{AMB} = +25^{\circ}C$			100	nA
V_{LBO}	LBO Voltage Low ⁽²⁾	$ILBO = 1mA$		20	100	mV
I_{LBO}	LBO Leakage Current	$LBO = 3.6V, T_{AMB} = +25^{\circ}C$			100	nA
	Power-OK Threshold	$LBI = 0V, \text{Falling Edge}$	90	92.5	95	%
Thermal Protection						
	Thermal Shutdown	$10^{\circ}C$ Hysteresis		150		$^{\circ}C$

Note(s) and/or Footnote(s):

- The regulator is in startup mode until this voltage is reached. Caution: Do not apply full load current until the device output > 1.75V.
- LBO goes low in startup mode as well as during normal operation if:
 - The voltage at the LBI pin is below LBI threshold.
 - The voltage at the LBI pin is below 0.1V and V_{OUT} is below 92.5% of its nominal value.

Typical Operating Characteristics

$T_{AMB} = +25^{\circ}\text{C}$, unless otherwise specified.

Figure 7:
Efficiency vs. Output Current; $V_{OUT} = 1.8\text{V}$

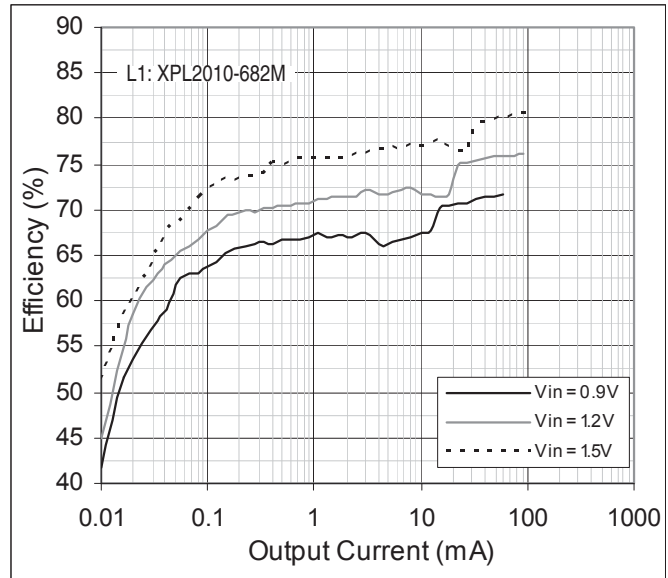

Figure 8:
Efficiency vs. Output Current; $V_{OUT} = 1.8\text{V}$

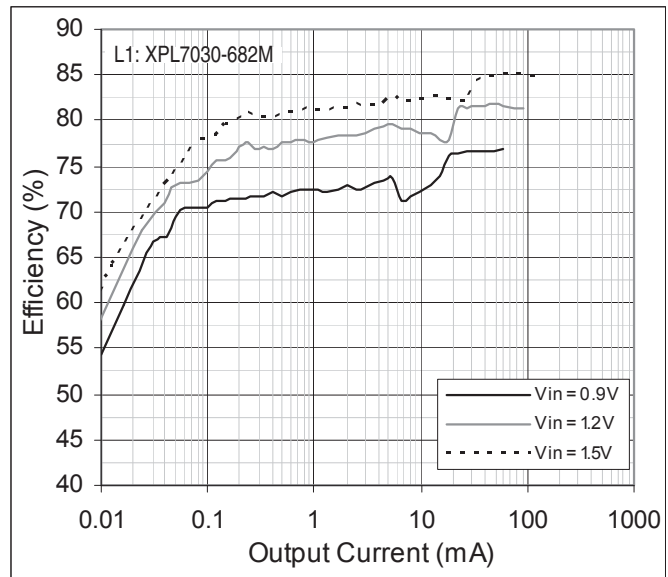

Figure 9:
Efficiency vs. Output Current; $V_{OUT} = 3.0V$

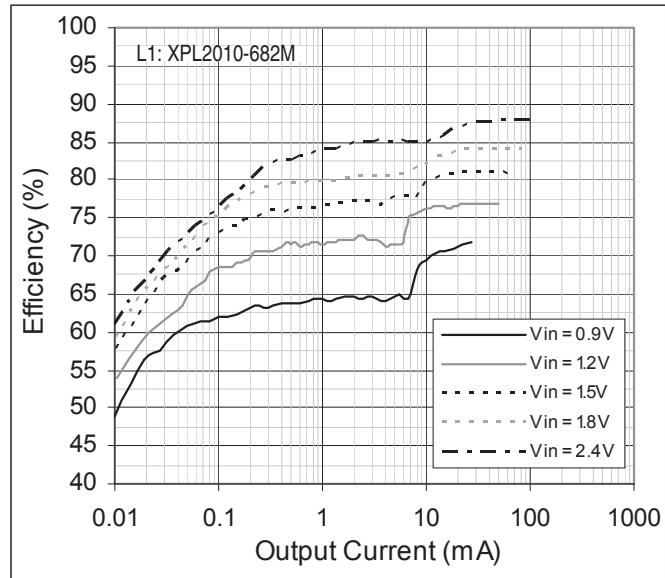

Figure 10:
Efficiency vs. Output Current; $V_{OUT} = 3.0V$

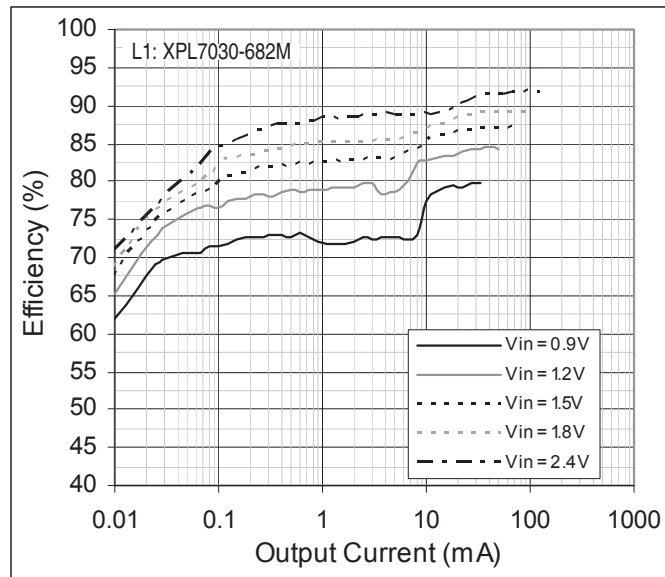

Figure 11:
Efficiency vs. Input Voltage; $V_{OUT} = 1.8V$

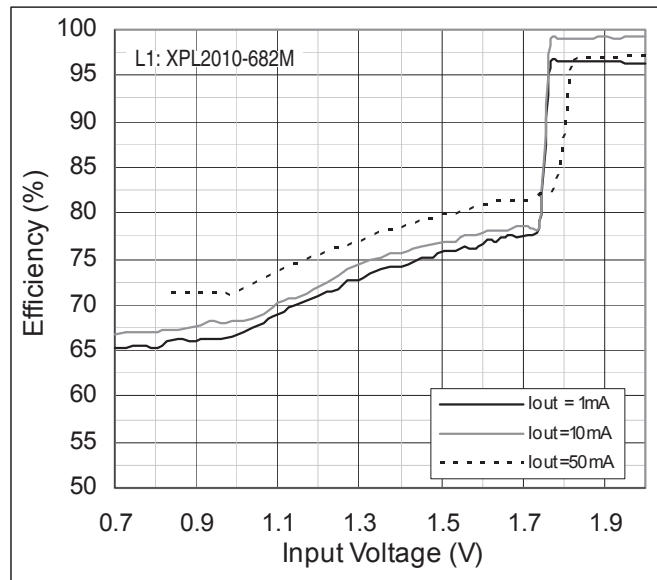

Figure 12:
Maximum Output Current vs. Input Voltage

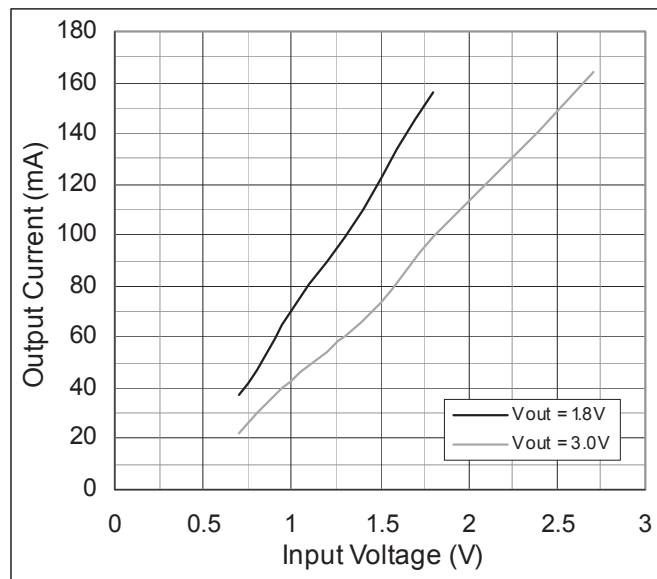

Figure 13:
Start-up Voltage vs. Output Current

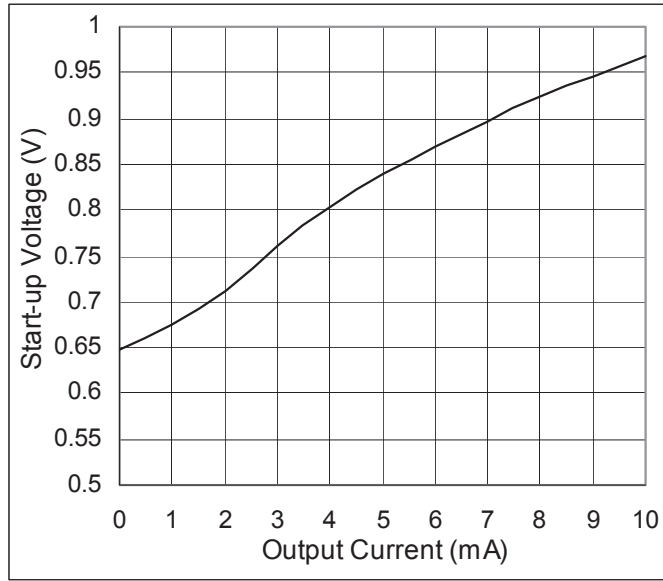

Figure 14:
RON vs. Temperature

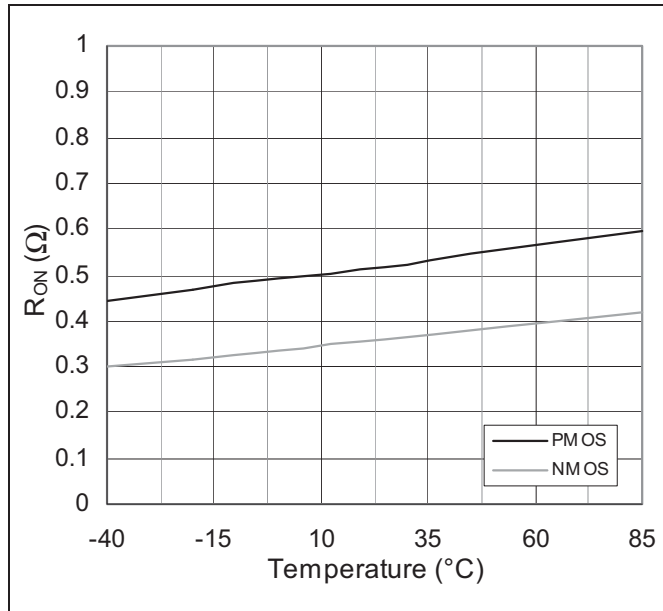
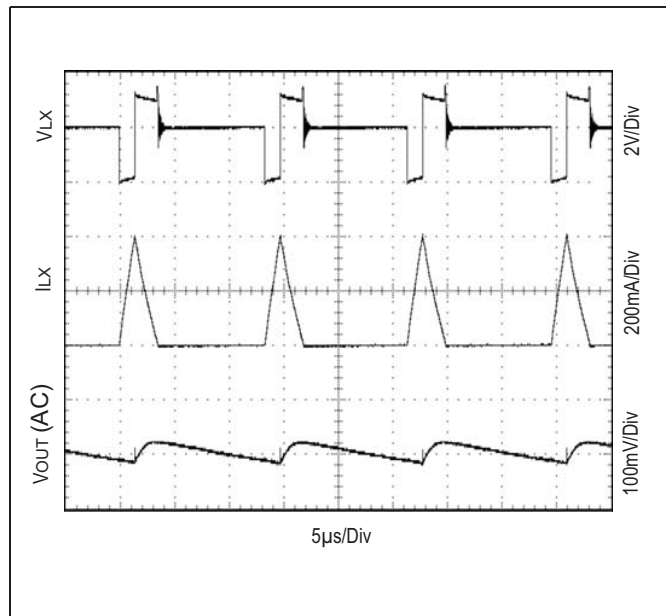

Figure 15:
Output Voltage Ripple; $V_{IN} = 2V$, $V_{OUT} = 3V$, $R_{load} = 100\Omega$



Detailed Description

Hysteretic Boost Converter

Hysteretic boost converters are so called because comparators are the active elements used to determine ON-OFF timing via current and voltage measurements. There is no continuously operating fixed oscillator, providing an independent timing reference. As a result, a hysteretic or comparator based converter has a very low quiescent current. In addition, because there is no fixed timing reference, the operating frequency is determined by external component (inductor and capacitors) and also the loading on the output.

Ripple at the output is an essential operating component. A power cycle is initiated when the output regulated voltage drops below the nominal value of V_{OUT} ($0.99 \times V_{OUT}$).

Inductor current is monitored by the control loop, ensuring that operation is always dis-continuous.

The application circuit shown in [Figure 2](#) will support many requirements. However, further optimization may be useful, and the following is offered as a guide to changing the passive components to more closely match the end requirement.

Input Loop Timing

The input loop consists of the source DC supply, the input capacitor, the main inductor, and the N-channel power switch. The ON timing of the N-channel switch is determined by a peak current measurement or a maximum ON time. In the AS1310, peak current is 400mA (typ) and maximum ON time is 4.2 μ s (typ). Peak current measurement ensures that the ON time varies as the input voltage varies. This imparts line regulation to the converter.

The fixed ON-time measurement is something of a safety feature to ensure that the power switch is never permanently ON. The fixed on-time is independent of input voltage changes. As a result, no line regulation exists.

Figure 16:
Simplified Boost DCDC Architecture

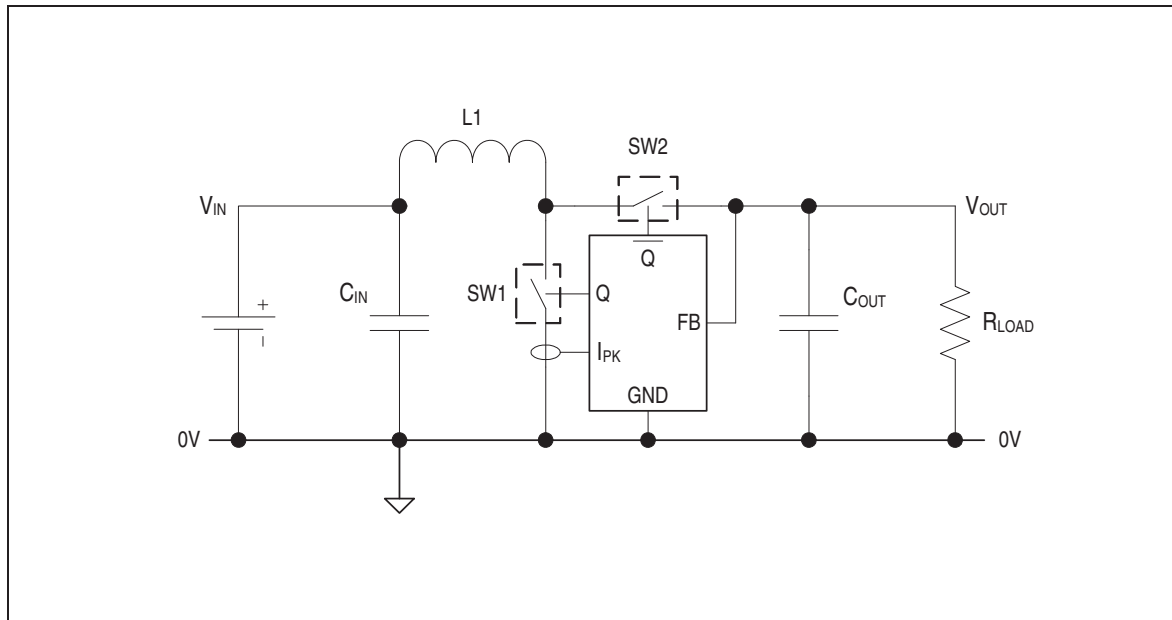

ON time of the power switch (Faraday's Law) is given by:

$$(EQ1) \quad T_{ON} = \frac{L I_{PK}}{V_{IN} - (I_{PK} R_{SW1} + I_{PK} R_{L1})} \text{ sec [volts, amps, ohms, Henry]}$$

Applying Min and Max values and neglecting the resistive voltage drop across L1 and SW1;

$$(EQ2) \quad T_{ON_MIN} = \frac{L_{MIN} I_{PK_MIN}}{V_{IN_MAX}}$$

$$(EQ3) \quad T_{ON_MAX} = \frac{L_{MAX} I_{PK_MAX}}{V_{IN_MIN}}$$

Figure 17:
Simplified Voltage and Current Waveforms

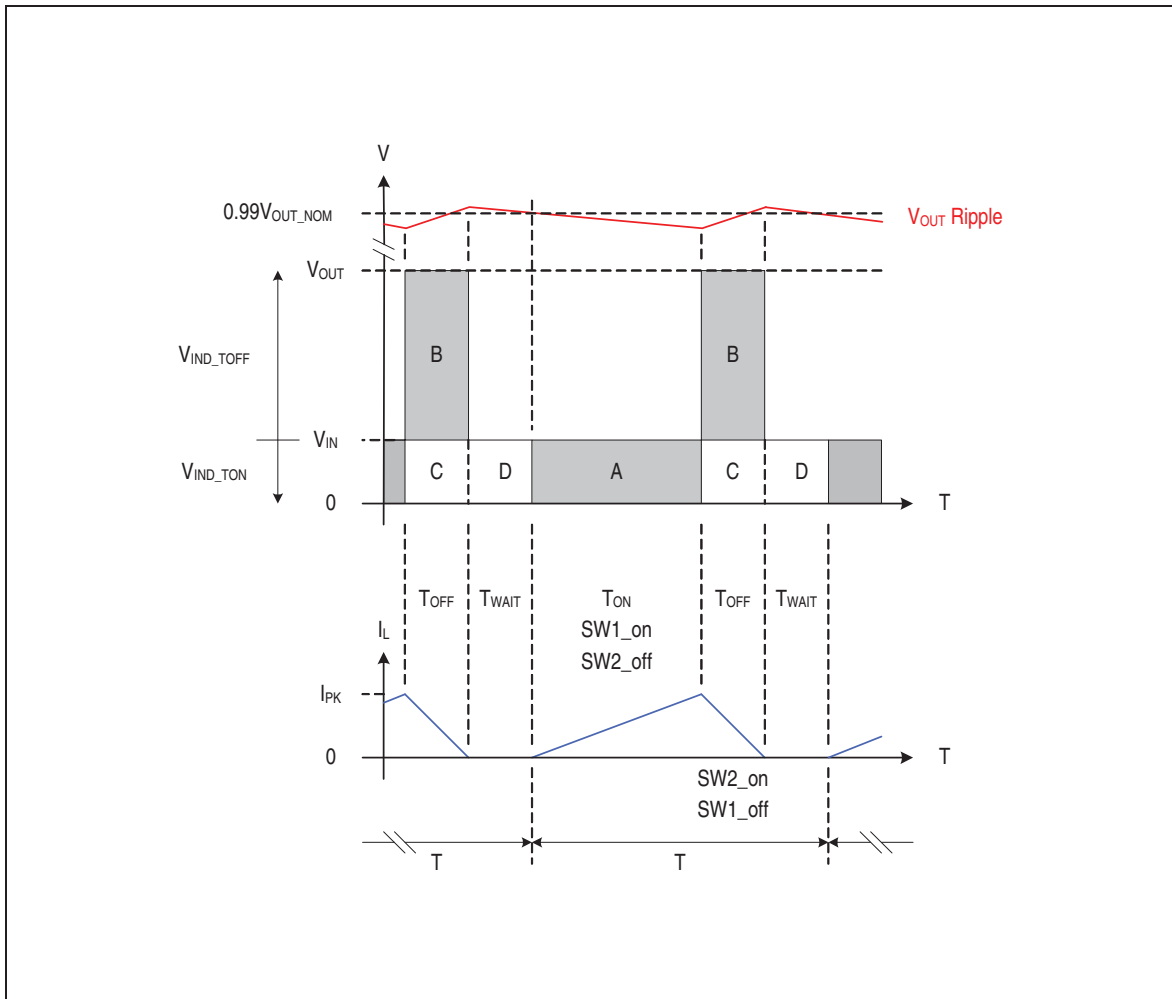

Another important relationship is the “volt-seconds” law. Expressed as following:

$$(EQ4) \quad V_{ON} T_{ON} = V_{OFF} T_{OFF}$$

Voltages are those measured across the inductor during each time segment. Figure 17 shows this graphically with the shaded segments marked “A & B”. Re-arranging EQ 4:

$$(EQ5) \quad \frac{T_{ON}}{T_{OFF}} = \frac{V_{OUT} - V_{IN}}{V_{IN}}$$

The time segment called T_{WAIT} in Figure 17 is a measure of the “hold-up” time of the output capacitor. While the output voltage is above the threshold ($0.99 \times V_{OUT}$), the output is assumed to be in regulation and no further switching occurs.

Inductor Choice Example

For the AS1310 $V_{IN_MIN} = 0.9V$, $V_{OUT_MAX} = 3.3V$, EQ 5 gives $T_{ON} = 2.66T_{OFF}$

Let the maximum operating on-time = $1\mu s$.

Note that this is shorter than the minimum limit ON-time of $3.6\mu s$. Therefore from EQ 5, $T_{OFF} = 0.376\mu s$. Using EQ 3, L_{MAX} is obtained:

$L_{MAX} = 1.875\mu H$. The nearest preferred value is $2.2\mu H$.

This value provides the maximum energy storage for the chosen fixed ON-time limit at the minimum V_{IN} .

Energy stored during the ON time is given by:

$$(EQ6) \quad E = 0.5L(I_{PK})^2 \text{ Joules (Region A in Figure 17)}$$

If the overall time period ($T_{ON} + T_{OFF}$) is T , the power taken from the input is:

$$(EQ7) \quad P_{IN} = \frac{0.5L(I_{PK})^2}{T} \text{ Watts}$$

Assume output power is $0.8 P_{IN}$ to establish an initial value of operating period T .

T_{WAIT} is determined by the time taken for the output voltage to fall to $0.99 \times V_{OUT}$. The longer the wait time, the lower will be the supply current of the converter. Longer wait times require increased output capacitance. Choose $T_{WAIT} = 10\% T$ as a minimum starting point for maximum energy transfer. For very low power load applications, choose $T_{WAIT} \geq 50\% T$.

Output Loop Timing

The output loop consists of the main inductor, P-channel synchronous switch (or diode if fitted), output capacitor and load. When the input loop is interrupted, the voltage on the LX pin rises (Lenz's Law). At the same time a comparator enables the synchronous switch, and energy stored in the inductor is transferred to the output capacitor and load. Inductor peak current supports the load and replenishes the charge lost from the output capacitor. The magnitude of the current from the inductor is monitored, and as it approaches zero, the synchronous switch is turned ON. No switching action continues until the output voltage falls below the output reference point ($0.99 \times V_{OUT}$).

Output power is composed of the DC component (Region C in Figure 17):

$$(EQ8) \quad P_{REGION_C} = V_{IN} \frac{I_{PK} T_{OFF}}{2 T}$$

Output power is also composed of the inductor component (Region B in Figure 17), neglecting efficiency loss:

$$(EQ9) \quad P_{REGION_B} = \frac{0.5L(I_{PK})^2}{T}$$

Total power delivered to the load is the sum of [EQ 8](#) and [EQ 9](#):

$$(EQ10) \quad P_{TOTAL} = V_{IN} \frac{I_{PK} T_{OFF}}{2T} + \frac{0.5L(I_{PK})^2}{T}$$

From [EQ 3](#) (using nominal values) peak current is given by:

$$(EQ11) \quad I_{PK} = \frac{T_{ON} V_{IN}}{L}$$

Substituting [EQ 11](#) into [EQ 10](#) and re-arranging:

$$(EQ12) \quad P_{TOTAL} = \frac{V_{IN}^2 T_{ON}}{2TL} (0.9T)$$

0.9T incorporates a wait time $T_{WAIT} = 10\% T$

Output power in terms of regulated output voltage and load resistance is:

$$(EQ13) \quad P_{OUT} = \frac{V_{OUT}^2}{R_{LOAD}}$$

Combining [EQ 12](#) and [EQ 13](#):

$$(EQ14) \quad \frac{V_{OUT}^2}{R_{LOAD}} = \frac{V_{IN}^2 T_{ON}}{2TL} (0.9T) \eta$$

Symbol η reflects total energy loss between input and output and is approximately 0.8 for these calculations. Use [EQ 14](#) to plot duty cycle (T_{ON}/T) changes for various output loadings and changes to V_{IN} .

Input Capacitor Selection

The input capacitor supports the triangular current during the ON-time of the power switch, and maintains a broadly constant input voltage during this time. The capacitance value is obtained from choosing a ripple voltage during the ON-time of the power switch. Additionally, ripple voltage is generated by the equivalent series resistance (ESR) of the capacitor. For worst case, use maximum peak current values from the datasheet.

$$(EQ15) \quad C_{IN} = \frac{I_{PEAK} T_{ON}}{V_{RIPPLE}}$$

Using $T_{ON} = 1\mu s$, and $I_{PEAK} = 480mA$, and $V_{RIPPLE} = 50mV$, [EQ 15](#) yields:

$$C_{IN} = 9.6\mu F$$

Nearest preferred would be 10 μF .

$$(EQ16) \quad V_{PK_RIPPLE_ESR} = I_{PK} R_{ESR}$$

Typically, the ripple due to ESR is not dominant. ESR for the recommended capacitors (Murata GMR), ESR = 5mΩ to 10mΩ. For the AS1310, maximum peak current is 480mA. Ripple due to ESR is 2.4mV to 4.8mV.

Ripple at the input propagates through the common supply connections, and if too high in value can cause problems elsewhere in the system. The input capacitance is an important component to get right.

Output Capacitor Selection

The output capacitor supports the triangular current during the OFF-time of the power switch (inductor discharge period), and also the load current during the wait time (Region D in [Figure 17](#)) and ON-time (Region A in [Figure 17](#)) of the power switch.

$$(EQ17) \quad C_{OUT} = \frac{I_{LOAD}(T_{ON} + T_{WAIT})}{(1 - 0.99)V_{OUT_NOM}}$$

Note(s): There is also a ripple component due to the equivalent series resistance (ESR) of the capacitor.

Summary

User Application Defines:

V_{INmin} , V_{INmax} , V_{OUTmin} , V_{OUTmax} , $I_{LOADmin}$, $I_{LOADmax}$

Inductor Selection:

Select Max on-time = 0.5μs to 3μs for AS1310. Use [EQ 3](#) to calculate inductor value.

Use [EQ 5](#) to determine OFF-time.

Use [EQ 6](#) to check that power delivery matches load requirements assume 70% conversion efficiency.

Use [EQ 13](#) to find overall timing period value of T at min V_{IN} and max V_{OUT} for maximum load conditions.

Input Capacitor Selection:

Choose a ripple value and use [EQ 14](#) to find the value.

Output Capacitor Selection:

Determine T_{WAIT} via [EQ 6](#) or [EQ 13](#), and use [EQ 16](#) to find the value.

Application Information

The AS1310 is available with fixed output voltages from 1.8V to 3.3V in 50mV steps.

Figure 18:
AS1310 Block Diagram

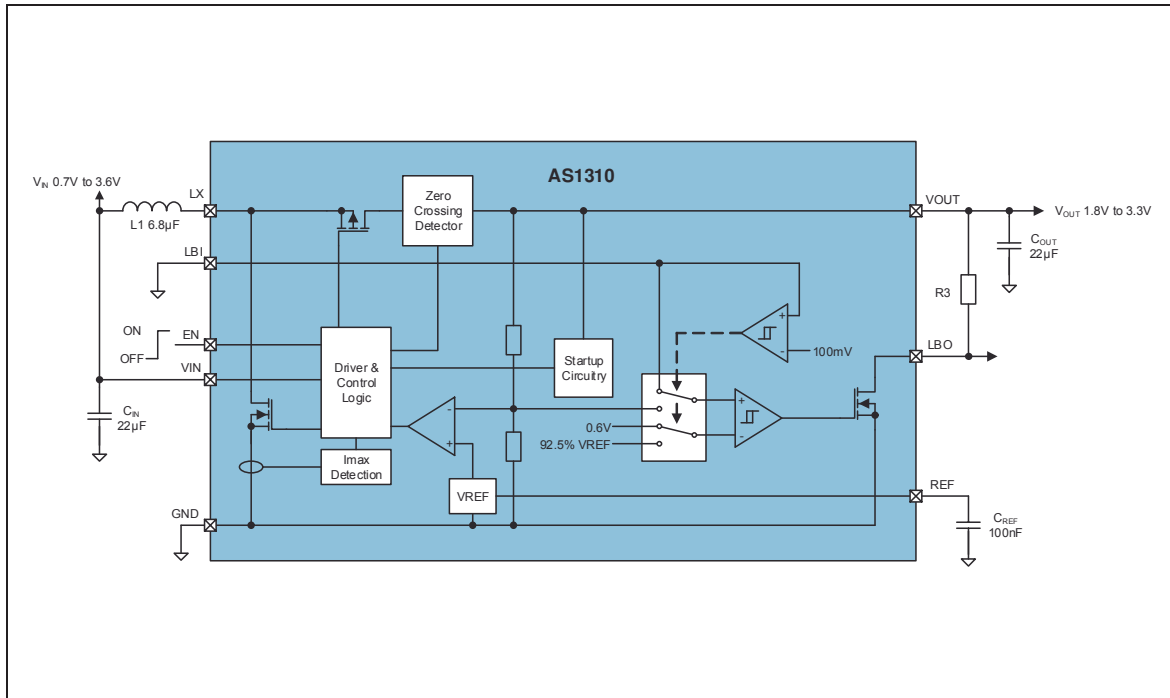

AS1310 Features

Shutdown. The part is in shutdown mode while the voltage at pin EN is below 0.1V and is active when the voltage is higher than 0.7V.

Note(s): EN can be driven above V_{IN} or V_{OUT} , as long as it is limited to less than 3.6V.

Output Disconnect and Inrush Limiting. During shutdown V_{OUT} is going to 0V and no current from the input source is running through the device. This is true as long as the input voltage is higher than the output voltage.

Feedthrough Mode. If the input voltage is higher than the output voltage the supply voltage is connected to the load through the device. To guarantee a proper function of the AS1310 it is not allowed that the supply exceeds the maximum allowed input voltage (3.6V).

In this feedthrough mode the quiescent current is 35μA (typ.). The device goes back into step-up mode when the output voltage is 4% (typ.) below V_{OUTNOM} .

Power-OK and Low-Battery-Detect Functionality

LBO goes low in startup mode as well as during normal operation if:

- The voltage at the LBI pin is below LBI threshold (0.6V). This can be used to monitor the battery voltage.
- LBI pin is connected to GND and V_{OUT} is below 92.5% of its nominal value. LBO works as a power-OK signal in this case.

The LBI pin can be connected to a resistive-divider to monitor a particular definable voltage and compare it with a 0.6V internal reference. If LBI is connected to GND an internal resistive-divider is activated and connected to the output. Therefore, the Power-OK functionality can be realized with no additional external components.

The Power-OK feature is not active during shutdown and provides a power-ON-reset function that can operate down to $V_{IN} = 0.7V$. A capacitor to GND may be added to generate a power-ON-reset delay. To obtain a logic-level output, connect a pull-up resistor R_3 from pin LBO to pin V_{OUT} . Larger values for this resistor will help to minimize current consumption; a 100k Ω resistor is perfect for most applications (see Figure 20).

For the circuit shown in the left of Figure 19, the input bias current into LBI is very low, permitting large-value resistor-divider networks while maintaining accuracy. Place the resistor-divider network as close to the device as possible. Use a defined resistor for R_2 and then calculate R_1 as:

$$(EQ18) \quad R_1 = R_2 \cdot \left(\frac{V_{IN}}{V_{LBI}} - 1 \right)$$

Where: V_{LBI} is 0.6V \pm 30mV

Figure 19:
Typical Application with Adjustable Battery Monitoring

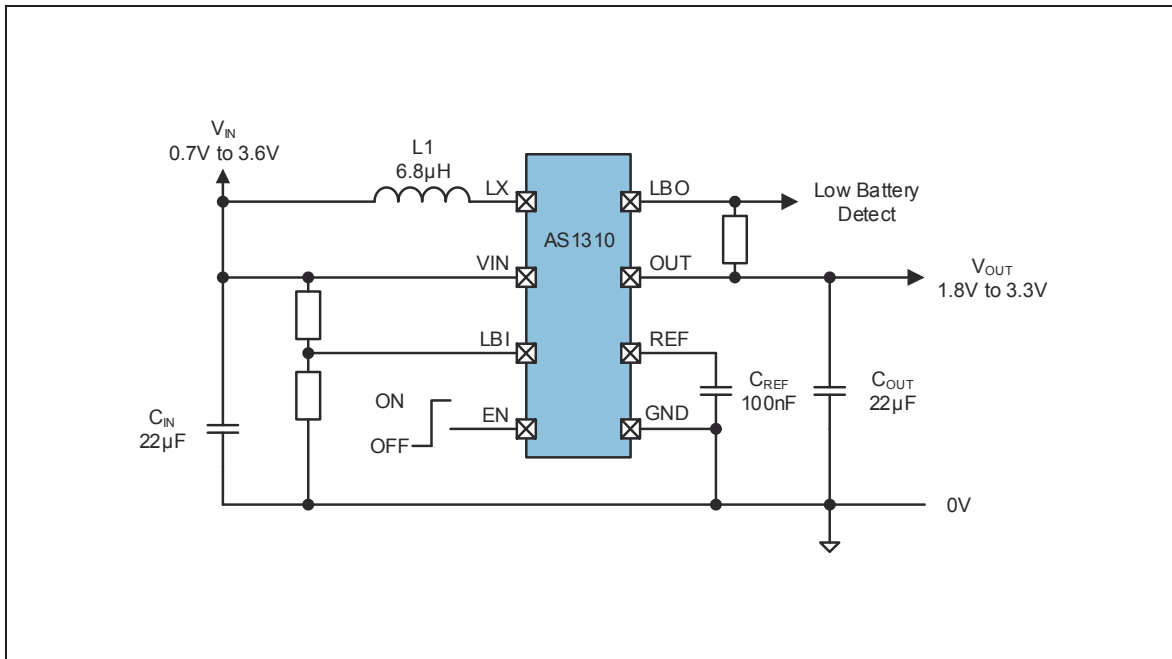
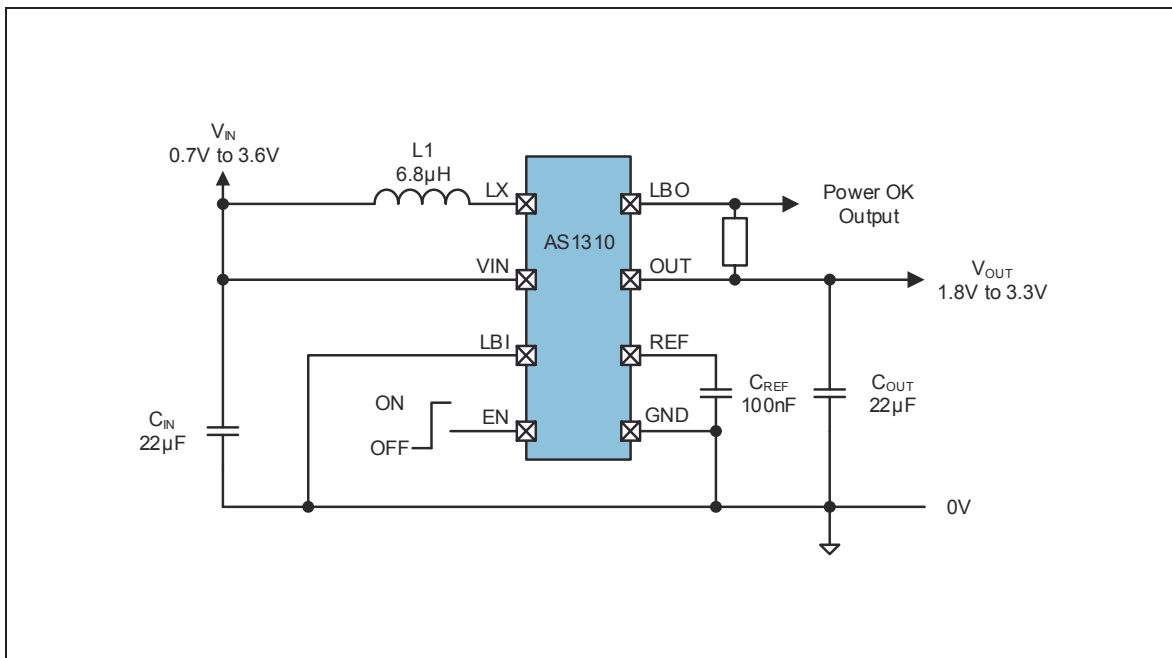

Figure 20:
Typical Application with LBO working as Power-OK



Thermal Shutdown

To prevent the AS1310 from short-term misuse and overload conditions the chip includes a thermal overload protection. To block the normal operation mode all switches will be turned OFF. The device is in thermal shutdown when the junction temperature exceeds 150°C. To resume the normal operation the temperature has to drop below 140°C.

A good thermal path has to be provided to dissipate the heat generated within the package. Otherwise it's not possible to operate the AS1310 at its usable maximal power. To dissipate as much heat as possible from the package into a copper plane with as much area as possible, it's recommended to use multiple vias in the printed circuit board. It's also recommended to solder the Exposed Pad (pin 9) to the GND plane.

Note(s): Continuing operation in thermal overload conditions may damage the device and is considered bad practice.

Always ON Operation

In battery powered applications with long standby times as blood glucose meters, remote controls, soap dispensers, etc., a careful battery management is required. Normally a complex power management control makes sure that the DCDC is only switched ON, when it is really needed. With AS1310 this complex control can be saved completely, since the AS1310 is perfectly suited to support always-ON operations of the application. The efficiency at standby currents of e.g. 2µAs is around 45% (see Figure 21).

Figure 21:
Efficiency vs. Output Current for Always ON Operation;
 $V_{OUT}=3.3V$

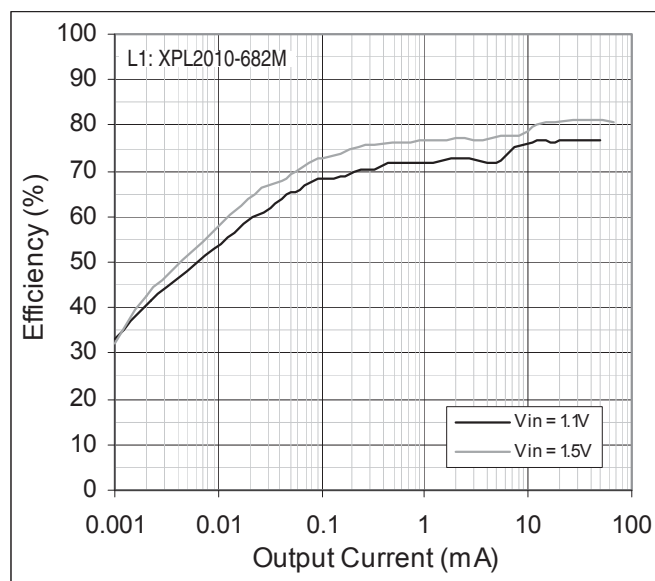

Component Selection

Only four components are required to complete the design of the step-up converter. The low peak currents of the AS1310 allow the use of low value, low profile inductors and tiny external ceramic capacitors.

Inductor Selection

For best efficiency, choose an inductor with high frequency core material, such as ferrite, to reduce core losses. The inductor should have low DCR (DC resistance) to reduce the I^2R losses, and must be able to handle the peak inductor current without saturating. A 6.8 μ H inductor with a >500mA current rating and <500m Ω DCR is recommended.

Figure 22:
Recommended Inductors

Part Number	L	DCR	Current Rating	Dimensions (L/W/T)	Manufacturer
XPL2010-682M	6.8 μ H	421m Ω	0.62A	2.0x1.9x1.0 mm	Coilcraft www.coilcraft.com
EPL2014-682M	6.8 μ H	287m Ω	0.59A	2.0x2.0x1.4 mm	
LPS3015-682M	6.8 μ H	300m Ω	0.86A	3.0x3.0x1.5 mm	
LPS3314-682M	6.8 μ H	240m Ω	0.9A	3.3x3.3x1.3 mm	
LPS4018-682M	6.8 μ H	150m Ω	1.3A	3.9x3.9x1.7 mm	
XPL7030-682M	6.8 μ H	59m Ω	9.4A	7.0x7.0x3.0 mm	
LQH32CN6R8M53L	6.8 μ H	250m Ω	0.54A	3.2x2.5x1.55 mm	Murata www.murata.com
LQH3NPN6R8NJ0L	6.8 μ H	210m Ω	0.7A	3.0x3.0x1.1 mm	
LQH44PN6R8MJ0L	6.8 μ H	143m Ω	0.72A	4.0x4.0x1.1 mm	

Capacitor Selection

The convertor requires three capacitors. Ceramic X5R or X7R types will minimize ESL and ESR while maintaining capacitance at rated voltage over temperature. The V_{IN} capacitor should be $22\mu\text{F}$. The V_{OUT} capacitor should be between $22\mu\text{F}$ and $47\mu\text{F}$. A larger output capacitor should be used if lower peak to peak output voltage ripple is desired. A larger output capacitor will also improve load regulation on V_{OUT} . See Figure 23 for a list of capacitors for input and output capacitor selection.

Figure 23:
Recommended Input and Output Capacitors

Part Number	C	TC Code	Rated Voltage	Dimensions (L/W/T)	Manufacturer
GRM21BR60J226ME99	$22\mu\text{F}$	X5R	6.3V	0805, T=1.25mm	Murata www.murata.com
GRM31CR61C226KE15	$22\mu\text{F}$	X5R	16V	1206, T=1.6mm	
GRM31CR60J475KA01	$47\mu\text{F}$	X5R	6.3V	1206, T=1.6mm	

On the pin REF a 10nF capacitor with an Insulation resistance $>1\text{G}\Omega$ is recommended.

Figure 24:
Recommended Capacitors for REF

Part Number	C	TC Code	Insulation Resistance	Rated Voltage	Dimensions (L/W/T)	Manufacturer
GRM188R71C104KA01	100nF	X7R	$>5\text{G}\Omega$	16V	0603, T=0.8mm	Murata www.murata.com
GRM31CR61C226KE15	100nF	X7R	$>5\text{G}\Omega$	50V	0805, T=1.25mm	

Layout Considerations

Relatively high peak currents of 480mA (max) circulate during normal operation of the AS1310. Long printed circuit tracks can generate additional ripple and noise that mask correct operation and prove difficult to “de-bug” during production testing. Referring to Figure 2, the input loop formed by C1, V_{IN} and GND pins should be minimized. Similarly, the output loop formed by C2, V_{OUT} and GND should also be minimized. Ideally both loops should connect to GND in a “star” fashion. Finally, it is important to return C_{REF} to the GND pin directly.

Package Drawings & Markings The device is available in a TDFN (2x2) 8-pin package.

Figure 25:
Drawings and Dimensions

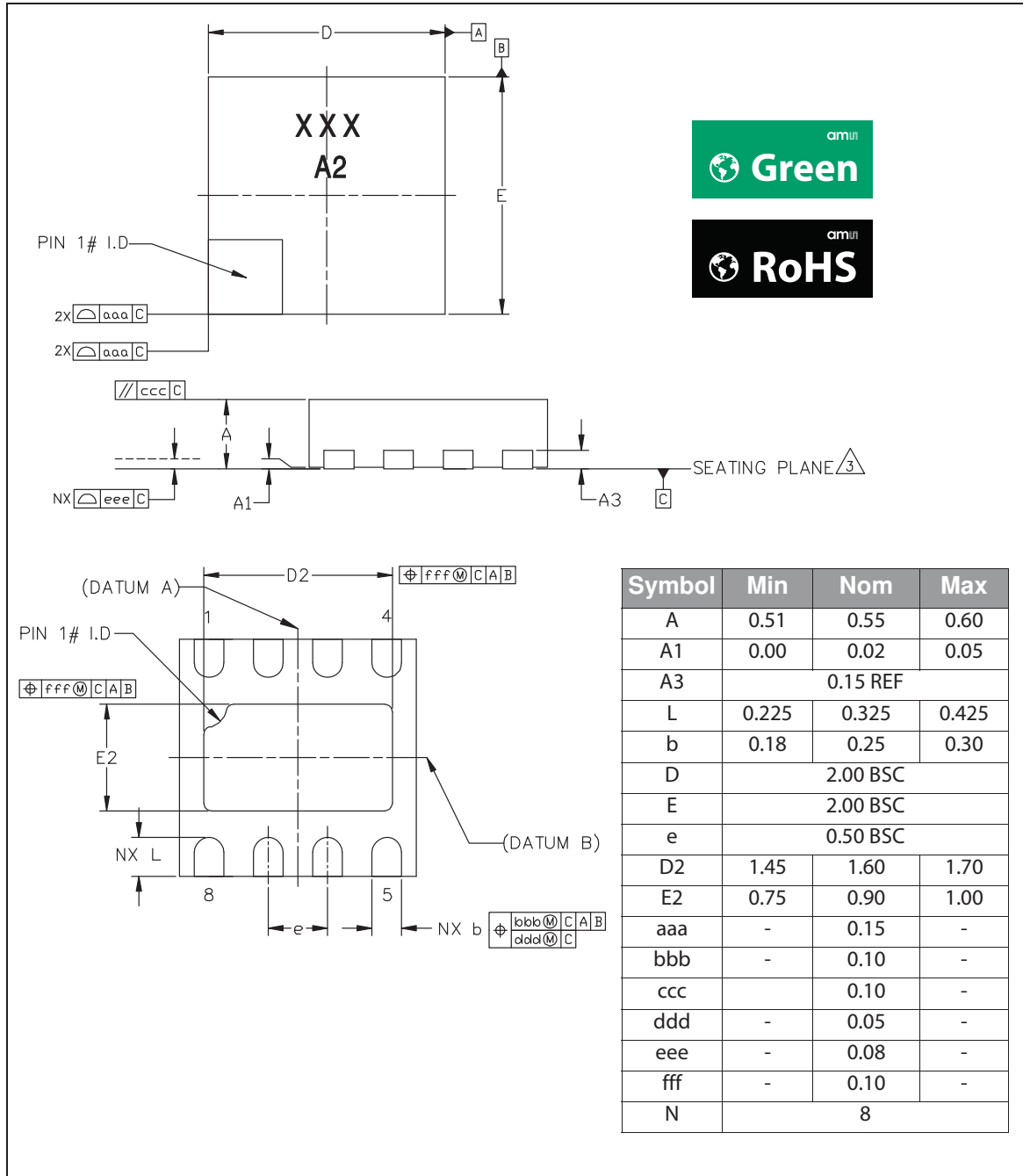

Note(s) and/or Footnote(s):

1. Dimensioning & tolerancing conform to ASME Y14.5M-1994.
2. All dimensions are in millimeters. Angles are in degrees.
3. Coplanarity applies to the exposed heat slug as well as the terminal.
4. Radius on terminal is optional.
5. N is the total number of terminals.

Ordering & Contact Information

The device is available as the standard products shown in [Figure 26](#).

Figure 26:
Ordering Information

Ordering Code	Marking	Output	Description	Delivery Form	Package
AS1310-BTDT-18	A2	1.8V	Ultra Low Quiescent Current, Hysteretic DC-DC Step-Up Converter	Tape and Reel	TDFN (2x2) 8-pin
AS1310-BTDT-20	A8	2.0V		Tape and Reel	TDFN (2x2) 8-pin
AS1310-BTDT-25	A9	2.5V		Tape and Reel	TDFN (2x2) 8-pin
AS1310-BTDT-27	A7	2.7V		Tape and Reel	TDFN (2x2) 8-pin
AS1310-BTDT-30	A6	3.0V		Tape and Reel	TDFN (2x2) 8-pin
AS1310-BTDT-33 ⁽¹⁾	tbd	3.3V		Tape and Reel	TDFN (2x2) 8-pin
AS1310-BTDT-xx ⁽²⁾	tbd	tbd		Tape and Reel	TDFN (2x2) 8-pin

Note(s) and/or Footnote(s):

1. On request
2. Non-standard devices are available between 1.8V and 3.3V in 50mV steps.

Buy our products or get free samples online at:

www.ams.com/ICdirect

Technical Support is available at:

www.ams.com/Technical-Support

Provide feedback about this document at:

www.ams.com/Document-Feedback

For further information and requests, e-mail us at:

ams_sales@ams.com

For sales offices, distributors and representatives, please visit:

www.ams.com/contact

Headquarters

ams AG
Tobelbaderstrasse 30
8141 Unterpremstaetten
Austria, Europe

Tel: +43 (0) 3136 500 0

Website: www.ams.com