



Chipsmall Limited consists of a professional team with an average of over 10 year of expertise in the distribution of electronic components. Based in Hongkong, we have already established firm and mutual-benefit business relationships with customers from,Europe,America and south Asia,supplying obsolete and hard-to-find components to meet their specific needs.

With the principle of “Quality Parts,Customers Priority,Honest Operation,and Considerate Service”,our business mainly focus on the distribution of electronic components. Line cards we deal with include Microchip,ALPS,ROHM,Xilinx,Pulse,ON,Everlight and Freescale. Main products comprise IC,Modules,Potentiometer,IC Socket,Relay,Connector.Our parts cover such applications as commercial,industrial, and automotives areas.

We are looking forward to setting up business relationship with you and hope to provide you with the best service and solution. Let us make a better world for our industry!



Contact us

Tel: +86-755-8981 8866 Fax: +86-755-8427 6832

Email & Skype: info@chipsmall.com Web: www.chipsmall.com

Address: A1208, Overseas Decoration Building, #122 Zhenhua RD., Futian, Shenzhen, China



AS1746

0.5/0.6Ω, Low-Voltage, Dual SPDT Analog Switch

1 General Description

The AS1746 is a low on-resistance (R_{ON}), low-voltage, dual-single-pole/double-throw (SPDT) analog switch designed to operate from a single +1.8 to +5.5V supply.

The device features a 0.5Ω (max) R_{ON} for normally closed (NC) switches and a 0.6Ω (max) R_{ON} for normally open (NO) switches using a +2.7V supply.

The AS1746 features break-before-make switching (2ns) with $t_{ON} = 50ns$ and $t_{OFF} = 30ns$ (using a +2.7V supply).

The digital logic inputs are 1.8V logic-compatible with +2.7 to +3.3V supplies.

The AS1746 is available in a TDFN-10 (3x3mm) package and a WL-CSP-10 package.

2 Key Features

- Single Supply Operation: +1.8V to +5.5V
- Normally Closed Switch R_{ON} : 0.45Ω (+2.7V Supply)
- Normally Open Switch R_{ON} : 0.55Ω (+2.7V Supply)
- R_{ON} Matching Between Channels: 0.06Ω
- R_{ON} Flatness Over Signal Range: 0.15Ω
- Supply Current: 50nA
- Rail-to-Rail Signal Handling
- 1.8V Logic Compatibility
- Low Crosstalk: -60dB (100kHz)
- High Off-Isolation: -64dB (100kHz)
- Total Harmonic Distortion: 0.025%
- Ultra-Low Leakage Currents: 1nA (@ $T_{AMB} = +25^{\circ}C$)
- Package Types:
 - TDFN-10 (3x3mm)
 - WL-CSP-10

3 Applications

The device is ideal for audio headsets, MP3 players, power routing switches, relay replacements, audio and video signal routing, communications circuits, PCMCIA cards, mobile phones, MODEMs, and any battery-operated equipment.

Figure 1. AS1746 - Block Diagram

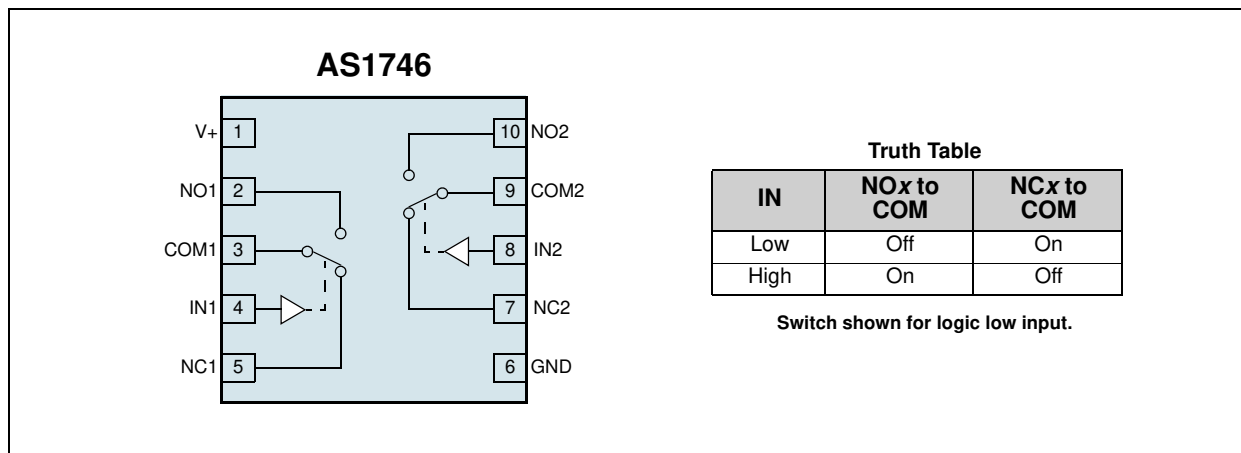

4 Pinout

Pin Assignments

Figure 2. Pin Assignments (Top View)

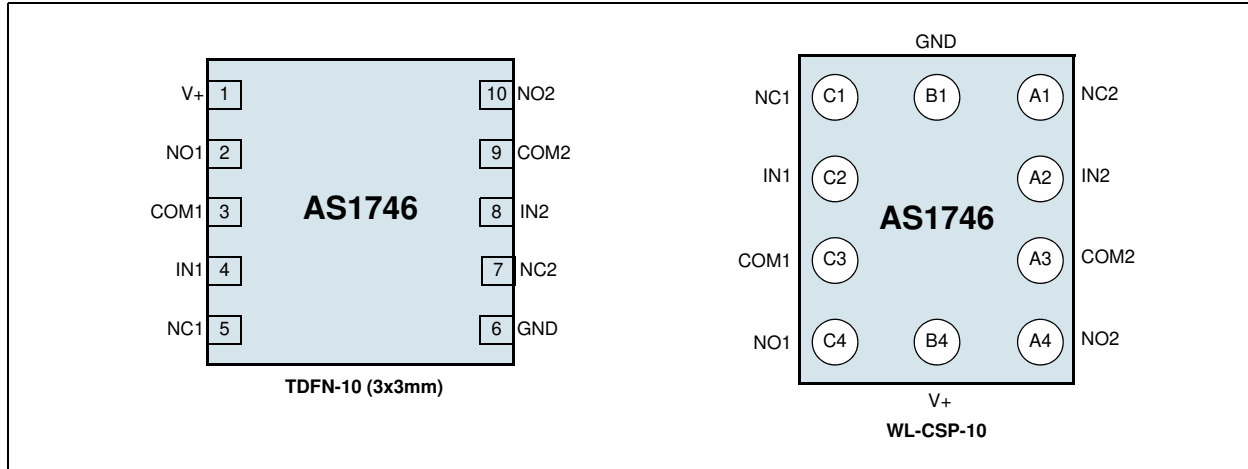

Pin Descriptions

Table 1. Pin Descriptions

Pin Number	Pin Name	Description
See Figure 2	V+	Positive Input Supply Voltage
	NO1	Normally Open Analog Switch 1
	COM1	Analog Switch 1 Common
	IN1	Switch 1 Digital Input
	NC1	Normally Closed Analog Switch 1
	GND	Ground
	NC2	Normally Closed Analog Switch 2
	IN2	Switch 2 Digital Input
	COM2	Analog Switch 2 Common
	NO2	Normally Open Analog Switch 2

5 Absolute Maximum Ratings

Stresses beyond those listed in [Table 2](#) may cause permanent damage to the device. These are stress ratings only, and functional operation of the device at these or any other conditions beyond those indicated in [Electrical Characteristics on page 4](#) is not implied. Exposure to absolute maximum rating conditions for extended periods may affect device reliability.

Table 2. Absolute Maximum Ratings

Parameter	Min	Max	Units	Comments
V+, INx to GND	-0.3	+7	V	
COMx, NOx, NCx, to GND	-0.3	V+ + 0.3	V	COMx, NOx, NCx signals exceeding V+ or GND are internally clamped by diodes and forward-diode current must be limited to the maximum current rating.
COMx, NOx, NCx Continuous Current	-300	+300	mA	
COMx, NOx, NCx Peak Current	-400	+400	mA	Pulsed at 50% duty cycle
COMx, NOx, NCx Peak Current	-500	+500	mA	Pulsed at 10% duty cycle
Continuous Power Dissipation		444	mW	T _{AMB} = +70°C
Electro-Static Discharge		2.5	kV	HBM Mil-Std883E 3015.7 methods
Latchup Immunity		250	mA	Class II, Level A
Operating Ambient Temperature Range	-40	+85	°C	
Storage Temperature Range	-65	+150	°C	
Package Body Temperature		+260	°C	The reflow peak soldering temperature (body temperature) specified is in accordance with IPC/JEDEC J-STD-020D "Moisture/Reflow Sensitivity Classification for Non-Hermetic Solid State Surface Mount Devices". The lead finish for Pb-free leaded packages is matte tin (100% Sn).

6 Electrical Characteristics

($V_+ = +2.7V$ to $+3.3V$, $V_{IH} = +1.4V$, $V_{IL} = +0.5V$, $T_{AMB} = -40^\circ C$ to $+85^\circ C$ (unless otherwise specified). Typical values are at $+3V$ and $+25^\circ C$.)

Table 3. Electrical Characteristics

Symbol	Parameter ¹	Condition	Min	Typ	Max	Unit
Analog Switch						
$V_{NOx}, V_{NCx}, V_{COMx}$	Analog Signal Range		0		V_+	V
$R_{ON(NC)}$	NCx On-Resistance	$V_+ = 2.7V, I_{COMx} = 100mA, V_{NCx} = 0$ to $V_+, T_{AMB} = 25^\circ C$		0.3	0.45	Ω
		$V_+ = 2.7V, I_{COMx} = 100mA, V_{NCx} = 0$ to V_+			0.5	
$R_{ON(NO)}$	NOx On-Resistance	$V_+ = 2.7V, I_{COMx} = 100mA, V_{NOx} = 0$ to $V_+, T_{AMB} = 25^\circ C$		0.35	0.55	Ω
		$V_+ = 2.7V, I_{COMx} = 100mA, V_{NOx} = 0$ to V_+			0.6	
ΔR_{ON}	On-Resistance Match Between Channels ²	$V_+ = 2.7V, I_{COMx} = 100mA, V_{NCx}/V_{NOx} = 1.5V$		0.02	0.06	Ω
$R_{FLAT(NC)}$	NCx On-Resistance Flatness ³	$V_+ = 2.7V, I_{COMx} = 100mA, V_{NCx} = 0$ to V_+		0.06	0.15	Ω
$R_{FLAT(NO)}$	NOx On-Resistance Flatness ³	$V_+ = 2.7V, I_{COMx} = 100mA, V_{NOx} = 0$ to V_+		0.1	0.35	Ω
I_{NOxOFF}/I_{NCxOFF}	NCx or NOx Off-Leakage Current ⁴	$V_+ = 3.3V, V_{NOx}/V_{NCx} = 3V, 0.3V, V_{COMx} = 0.3V, 3V, T_{AMB} = 25^\circ C$	-1		1	nA
		$V_+ = 3.3V, V_{NOx}/V_{NCx} = 3V, 0.3V, V_{COMx} = 0.3V, 3V$	-10		10	nA
I_{COMxON}	COMx On-Leakage Current ⁴	$V_+ = 3.3V, V_{NOx}/V_{NCx} = 3V, 0.3V$ or float, $V_{COMx} = 3V, 0.3V$, or float, $T_{AMB} = 25^\circ C$	-2		2	nA
		$V_+ = 3.3V, V_{NOx}/V_{NCx} = 3V, 0.3V$ or float, $V_{COMx} = 3V, 0.3V$, or float	-30		30	nA
Dynamic Characteristics						
t_{ON}	Turn On Time ⁵	$V_+ = 2.7V, V_{NOx}/V_{NCx} = 1.5V, R_{LOAD} = 50\Omega, C_{LOAD} = 35pF, T_{AMB} = 25^\circ C$		30	50	ns
		$V_+ = 2.7V, V_{NOx}/V_{NCx} = 1.5V, R_{LOAD} = 50\Omega, C_{LOAD} = 35pF$ (see Figure 17 on page 10)			60	
t_{OFF}	Turn Off Time ⁵	$V_+ = 2.7V, V_{NOx}/V_{NCx} = 1.5V, R_{LOAD} = 50\Omega, C_{LOAD} = 35pF, T_{AMB} = 25^\circ C$		20	30	ns
		$V_+ = 2.7V, V_{NOx}/V_{NCx} = 1.5V, R_{LOAD} = 50\Omega, C_{LOAD} = 35pF$ (see Figure 17 on page 10)			35	
t_{BBM}	Break-Before-Make Delay ⁵	$V_+ = 2.7V, V_{NOx}/V_{NCx} = 1.5V, R_{LOAD} = 50\Omega, C_{LOAD} = 35pF$ (see Figure 18 on page 10)	2	15		ns
Q	Charge Injection	COMx = 0, $R_S = 0, C_{LOAD} = 1nF$ (see Figure 19 on page 10)		200		pC

Table 3. Electrical Characteristics (Continued)

Symbol	Parameter ¹	Condition	Min	Typ	Max	Unit
V _{ISO}	Off-Isolation ⁶	V _{COMx} = 1V _{RMS} , R _{LOAD} = 50Ω, C _{LOAD} = 5pF, f = 100kHz (see Figure 20 on page 11)		-64		dB
V _{XT}	Crosstalk	V _{COMx} = 1V _{RMS} , R _{LOAD} = 50Ω, C _{LOAD} = 5pF, f = 100kHz (see Figure 20 on page 11)		-60		dB
THD	Total Harmonic Distortion	R _{LOAD} = 600Ω, I _{Nx} = 2VP-P, f = 20Hz to 20kHz		0.025		%
CNCXOFF	NCx Off-Capacitance	f = 1MHz (see Figure 21 on page 11)		84		pF
CNOXOFF	NOx Off-Capacitance	f = 1MHz (see Figure 21 on page 11)		37		pF
CNCXON	NCx On-Capacitance	f = 1MHz (see Figure 21 on page 11)		190		pF
CNOXON	NOx On-Capacitance	f = 1MHz (see Figure 21 on page 11)		150		pF
Digital I/O						
V _{IH}	Input Logic High		1.4			V
V _{IL}	Input Logic Low				0.5	V
I _{INx}	I _{Nx} Input Leakage Current	V _{INx} = 0 or V+	-1		1	μA
Power Supply						
V+	Power Supply Range		1.8		5.5	V
I+	Supply Current	V+ = 5.5V; V _{INx} = 0 or V+, T _{AMB} = 25°C	-50		50	nA
		V+ = 5.5V; V _{INx} = 0 or V+	-350		350	

1. The algebraic convention used in this data sheet is such that the most negative value is the minimum and the most positive value is the maximum.
2. $\Delta R_{ON} = R_{ON(MAX)} - R_{ON(MIN)}$ between pins NC1 and NC2 or between pins NO1 and NO2.
3. Flatness is defined as the difference between the maximum and minimum value of R_{ON} as measured over the specified analog signal ranges.
4. 100% tested.
5. Guaranteed by design.
6. Off-isolation = 20LOG₁₀ (V_{COM}/V_{NO}), V_{COM} = output, V_{NO} = input to off switch.

7 Typical Operating Characteristics

$T_{AMB} = +25^{\circ}\text{C}$. Values measured in TDFN-10 (3x3mm) package.

Figure 3. NC ON-Resistance vs. V_{COM}

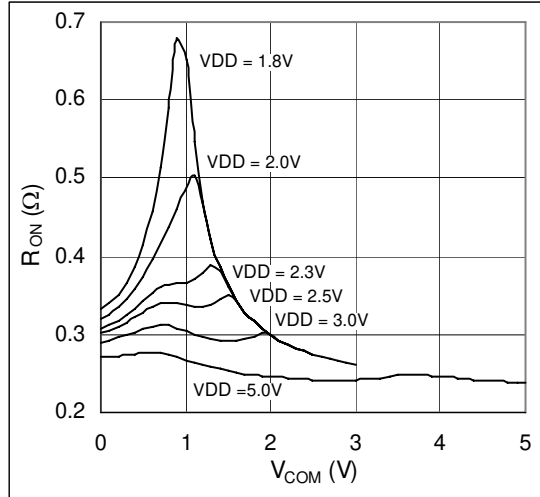

Figure 4. NO ON-Resistance vs. V_{COM}

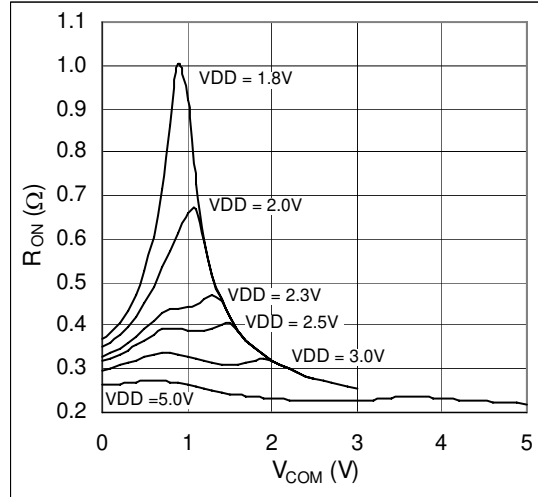

Figure 5. NC ON-Resistance vs. V_{COM} , 5V

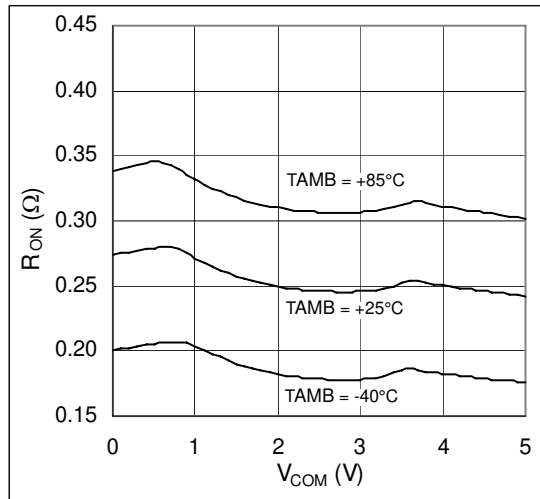

Figure 6. NO ON-Resistance vs. V_{COM} , 5V

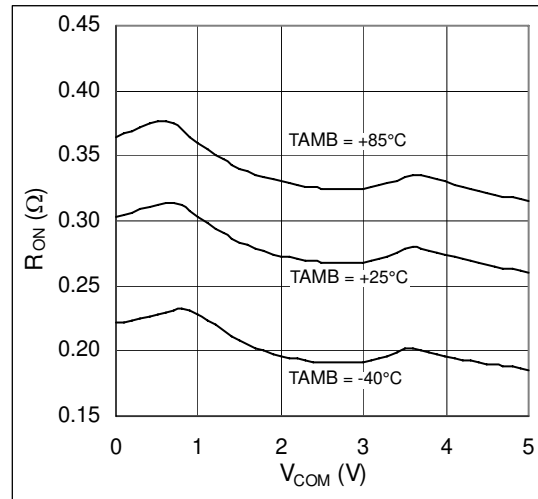

Figure 7. NC ON-Resistance vs. V_{COM} , 3V

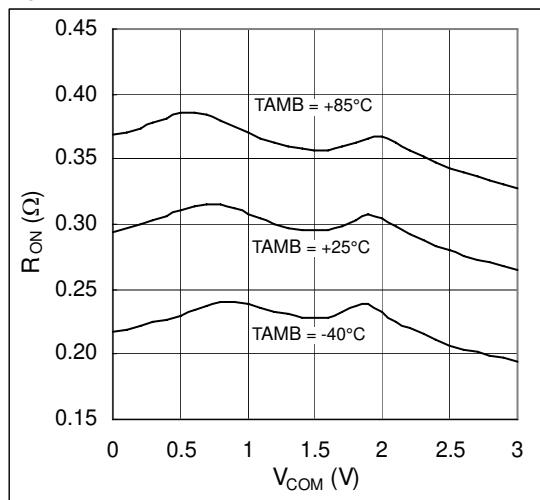

Figure 8. NO ON-Resistance vs. V_{COM} , 3V

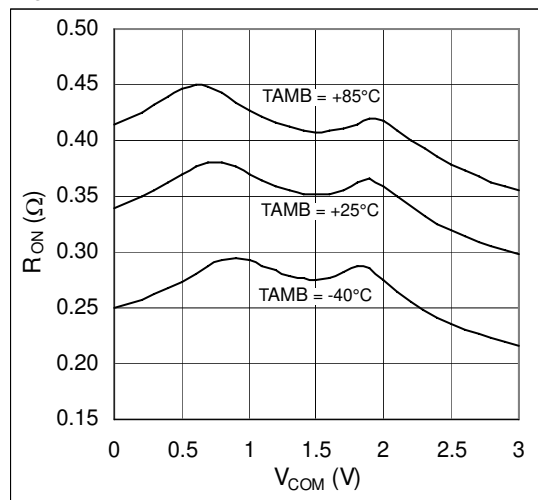

Figure 9. Turn-ON/OFF vs. Temperature, $V_{DD} = 3V$

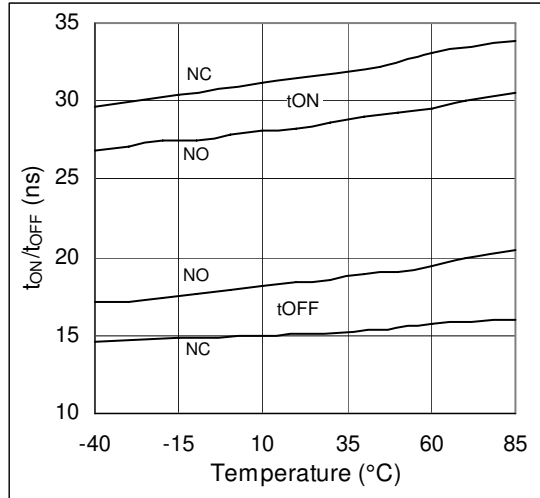

Figure 10. Turn-ON/OFF Times vs. V_{Supply}

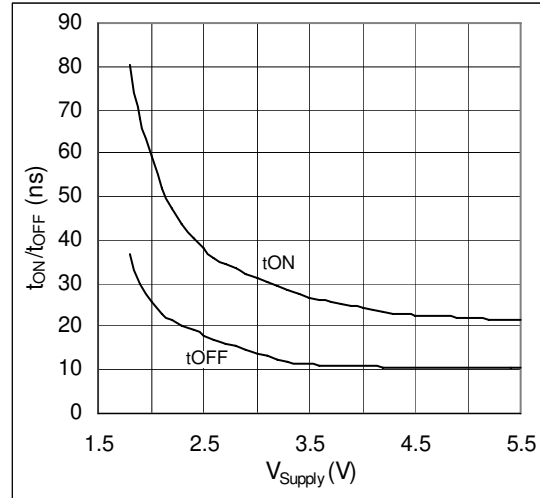

Figure 11. Logic Threshold Voltage vs. Supply Voltage

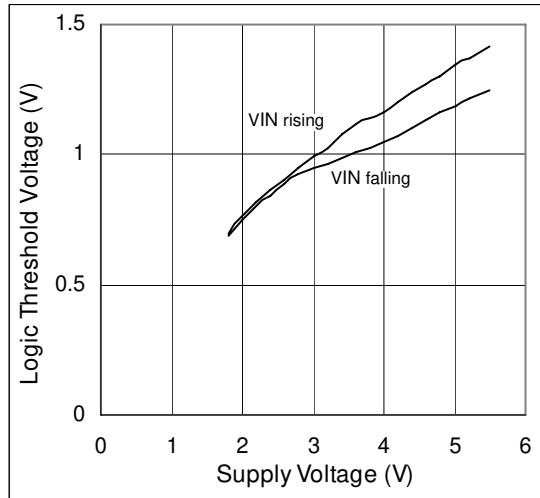

Figure 12. Charge Injection vs. COM Voltage

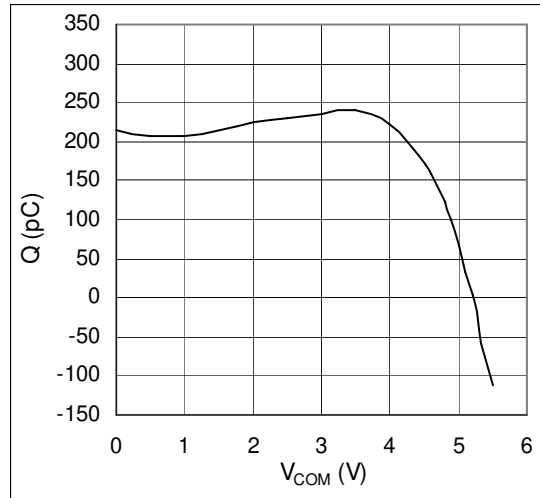

Figure 13. Frequency Response

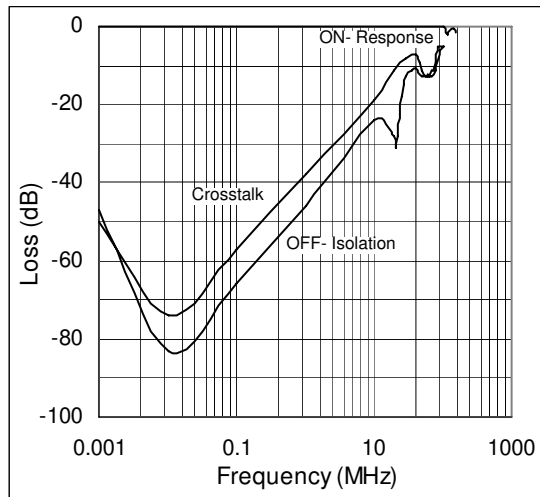
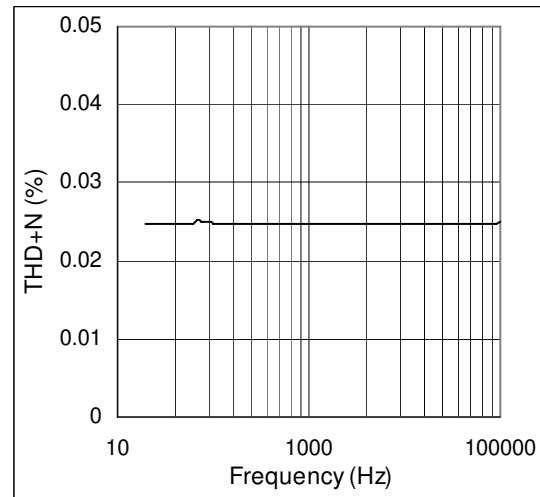

Figure 14. THD+N vs. Frequency



8 Detailed Description

The AS1746 is a low on-resistance, low-voltage, asymmetrical dual-SPDT analog switch designed to operate from a single +1.8 to +5.5V supply. The device is fully specified for nominal 3V applications and features break-before-make switching and fast switching speeds ($t_{ON} = 60\text{ns}$ max, $t_{OFF} = 35\text{ns}$ max).

The device provides 0.5Ω (max) R_{ON} for its NC switch, and 0.6Ω (max) R_{ON} for its NO switch for applications that require asymmetrical loads.

Figure 15. AS1746 - Block Diagram – WL-CSP-10

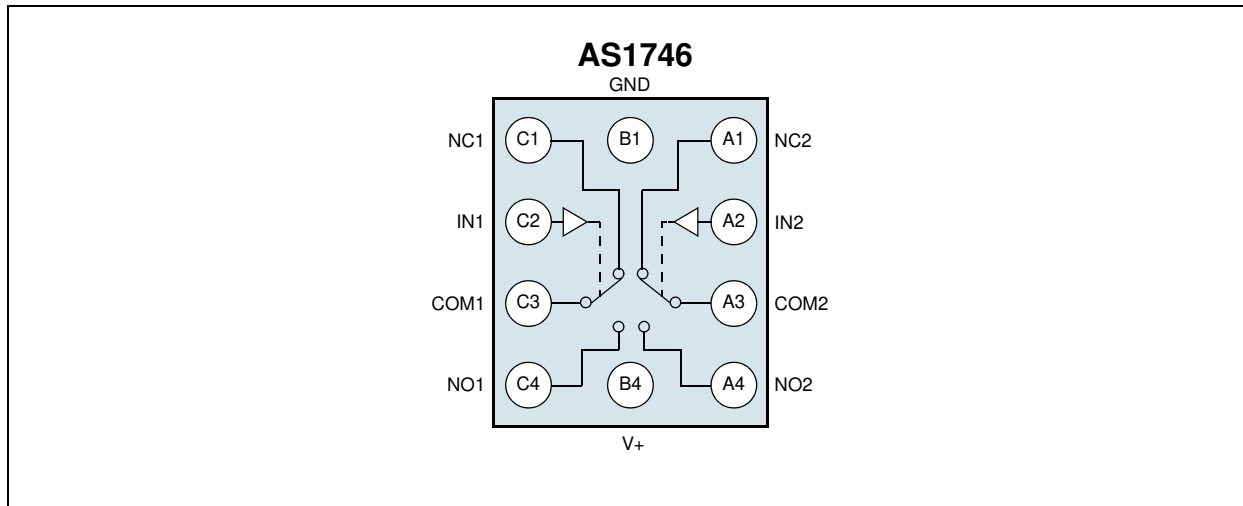

9 Application Information

Digital Control Inputs

The AS1746 logic inputs can handle up to +5.5V regardless of the supply voltage. For example, with a +3.3V supply, IN_x may be driven low to GND and high to 5.5V. Driving IN_x rail-to-rail minimizes power consumption.

Analog Signal Levels

Analog signals that range over the entire supply voltage (V₊ to GND) are passed with very little change in R_{ON} (see [Typical Operating Characteristics on page 6](#)). The switches are bi-directional, so the NO_x, NC_x, and COM_x pins can be used as inputs or outputs.

Power Supply Sequencing

Proper power supply sequencing is recommended for all CMOS devices. The recommended sequence is as follows:

1. V₊
2. NO_x, NC_x, COM_x

Always apply V₊ before applying analog signals, especially if the analog signal is not current limited. If this sequencing is not possible, and if the analog inputs are not current limited to <20mA, add a small signal protection diode (D1) as shown in [Figure 16](#).

Overvoltage Protection

Using a protection diode will reduce the analog range to a diode voltage drop (approximately 0.7V) below V₊ (for D1). R_{ON} will increase slightly at low supply voltages.

Caution: The maximum supply voltage (V₊) must not exceed +7V. Do not exceed the absolute maximum ratings because stresses beyond the ratings listed in [Absolute Maximum Ratings on page 3](#) may cause permanent damage to the device.

Note: Protection diode D1 can also protect the device from some overvoltage conditions.

Figure 16. Overvoltage Protections using 2 External Blocking Diodes

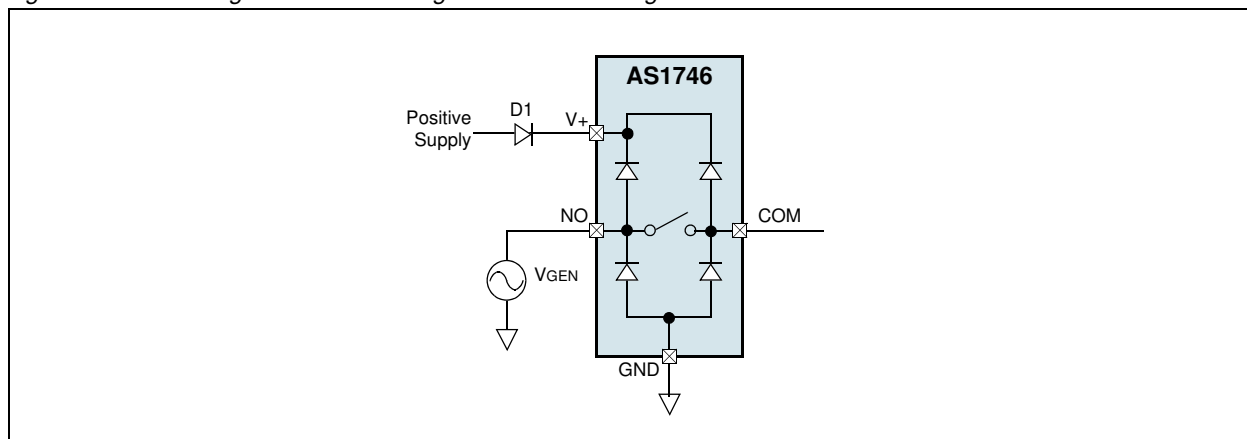

Note: No damage will result to the circuit shown in [Figure 16](#) if the supply voltage is below the absolute maximum rating applied to an analog signal pin (NO_x, NC_x, or COM_x).

Test Circuits and Timing Diagrams

Figure 17. Switching Time

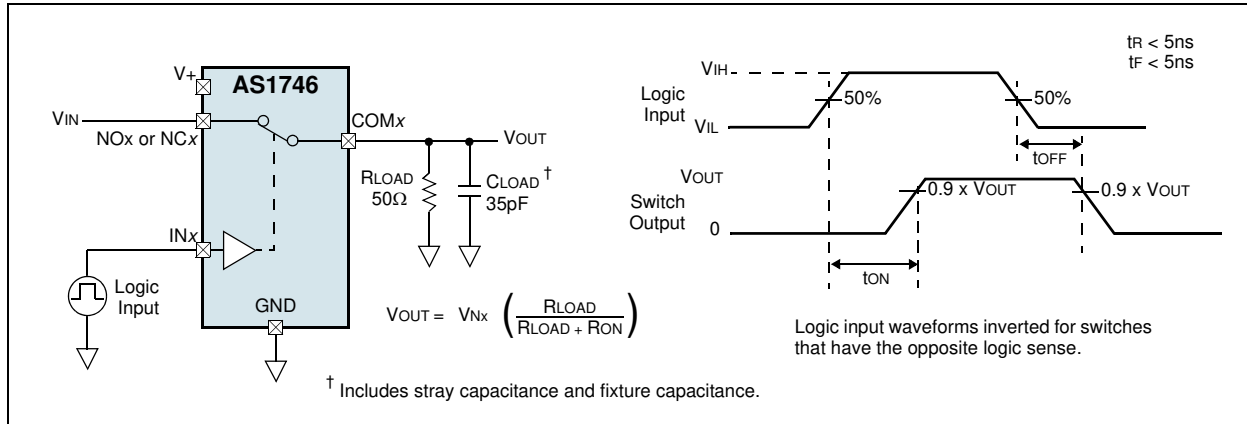

Figure 18. Break-Before-Make Interval

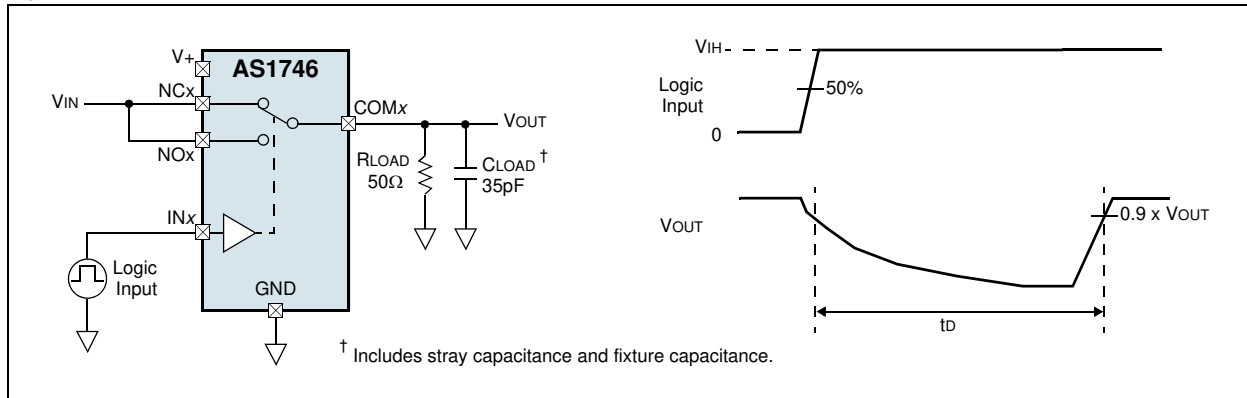

Figure 19. Charge Injection

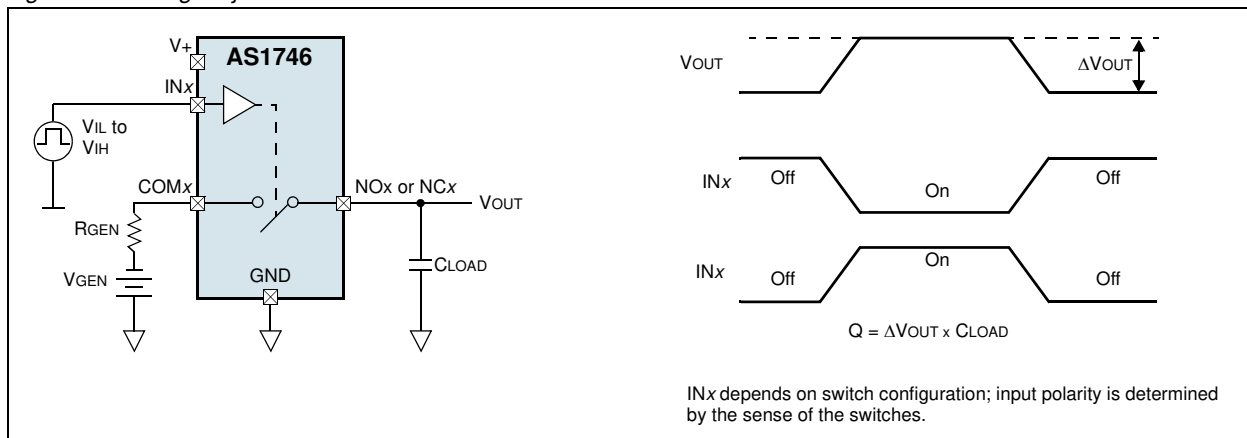
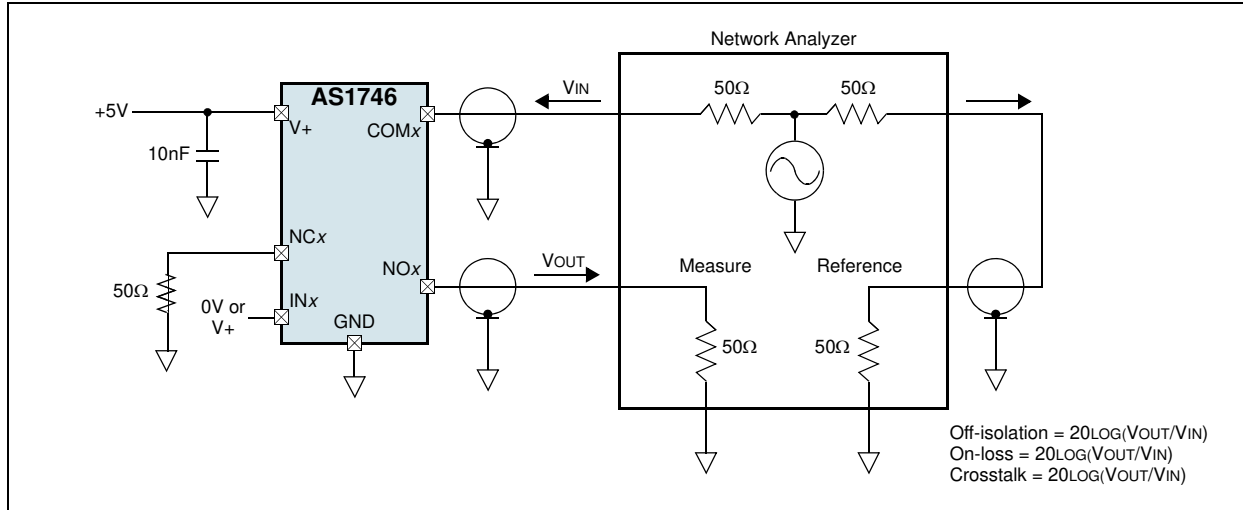

Figure 20. On-Loss, Off-Isolation, Crosstalk



Notes:

1. Measurements are standardized against short-circuit at all terminals.
2. Off-isolation is measured between COMx and the off NCx/NOx terminal of each switch.
3. Crosstalk is measured from one channel to all other channels.
4. Signal direction through the switch is reversed; worst values are recorded.

Figure 21. Channel On- Off-Capacitance

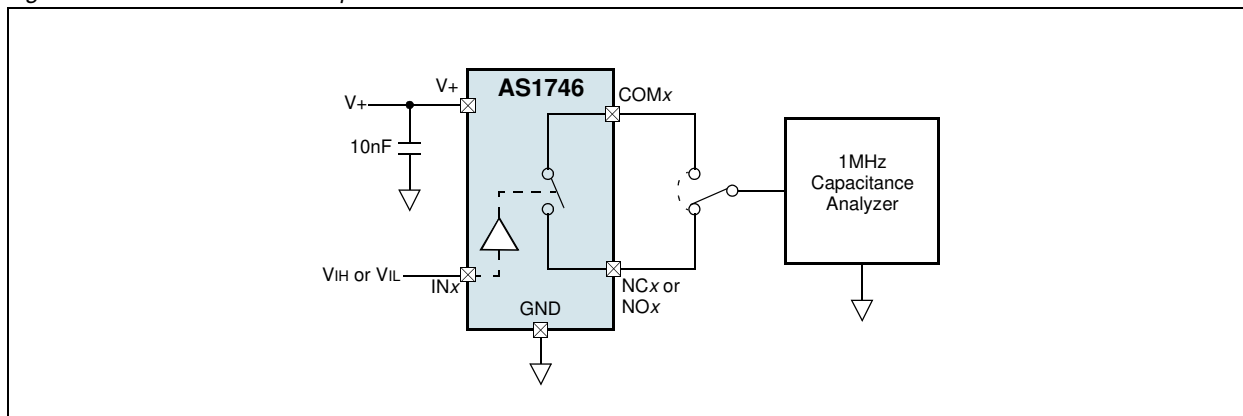

10 Package Drawings and Markings

The device is available in a TDFN-10 (3x3mm) package and a WL-CSP-10 package.

Figure 22. TDFN-10 (3x3mm) Package

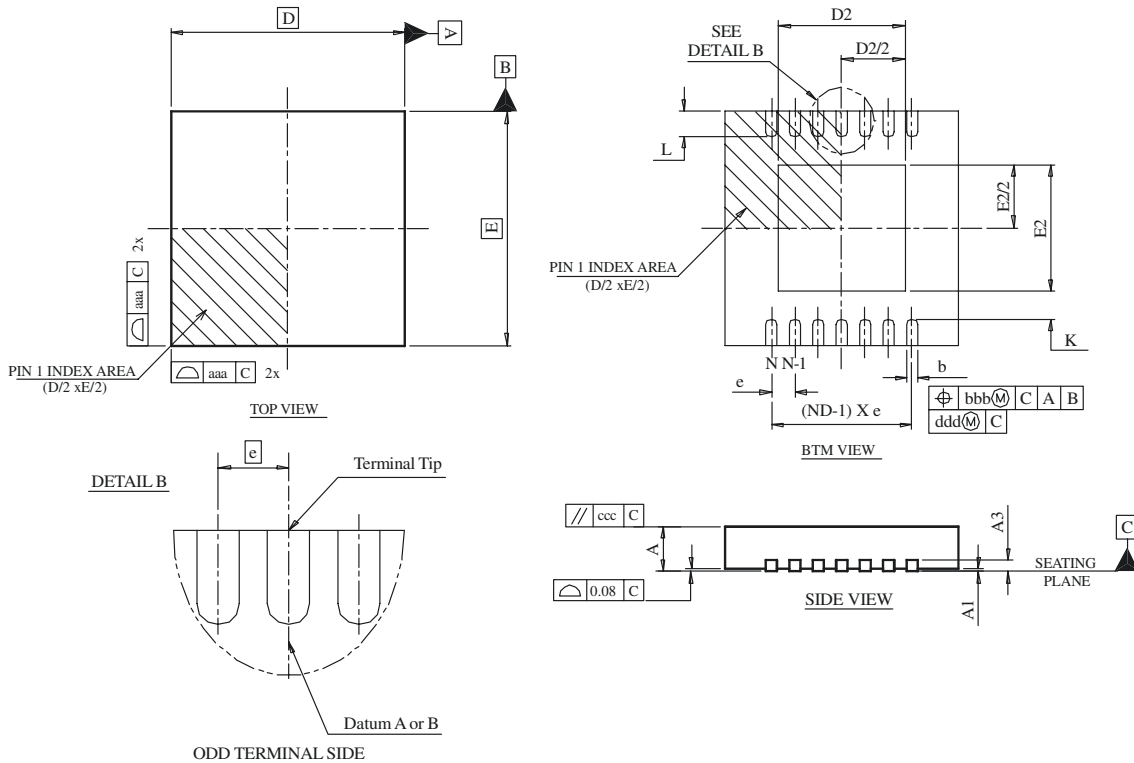

Symbol	Min	Typ	Max	Notes
A	0.70	0.75	0.80	1, 2
A1	0.00	0.02	0.05	1, 2
A3		0.20 REF		1, 2
L	0.30	0.40	0.50	1, 2
aaa		0.15		1, 2
bbb		0.10		1, 2
ccc		0.10		1, 2
ddd		0.05		1, 2
eee		0.08		1, 2
ggg		0.10		1, 2

Symbol	Min	Typ	Max	Notes
D BSC		3.00		1, 2
E BSC		3.00		1, 2
D2	2.20		2.70	1, 2
E2	1.40		1.75	1, 2
θ	0°		14°	1, 2
K	0.20			1, 2
b	0.18	0.25	0.30	1, 2, 5
e		0.50		
N		10		1, 2
ND		5		1, 2, 5

Notes:

- Figure 22 is shown for illustration only.
- All dimensions are in millimeters; angles in degrees.
- Dimensioning and tolerancing conform to *ASME Y14.5 M-1994*.
- N is the total number of terminals.
- The terminal #1 identifier and terminal numbering convention shall conform to *JEDEC 95-1, SPP-012*. Details of terminal #1 identifier are optional, but must be located within the zone indicated. The terminal #1 identifier may be either a mold or marked feature.
- Dimension b applies to metallized terminal and is measured between 0.15mm and 0.30mm from the terminal tip.
- ND refers to the maximum number of terminals on side D.
- Unilateral coplanarity zone applies to the exposed heat sink slug as well as the terminals

Figure 23. WL-CSP-10 Package

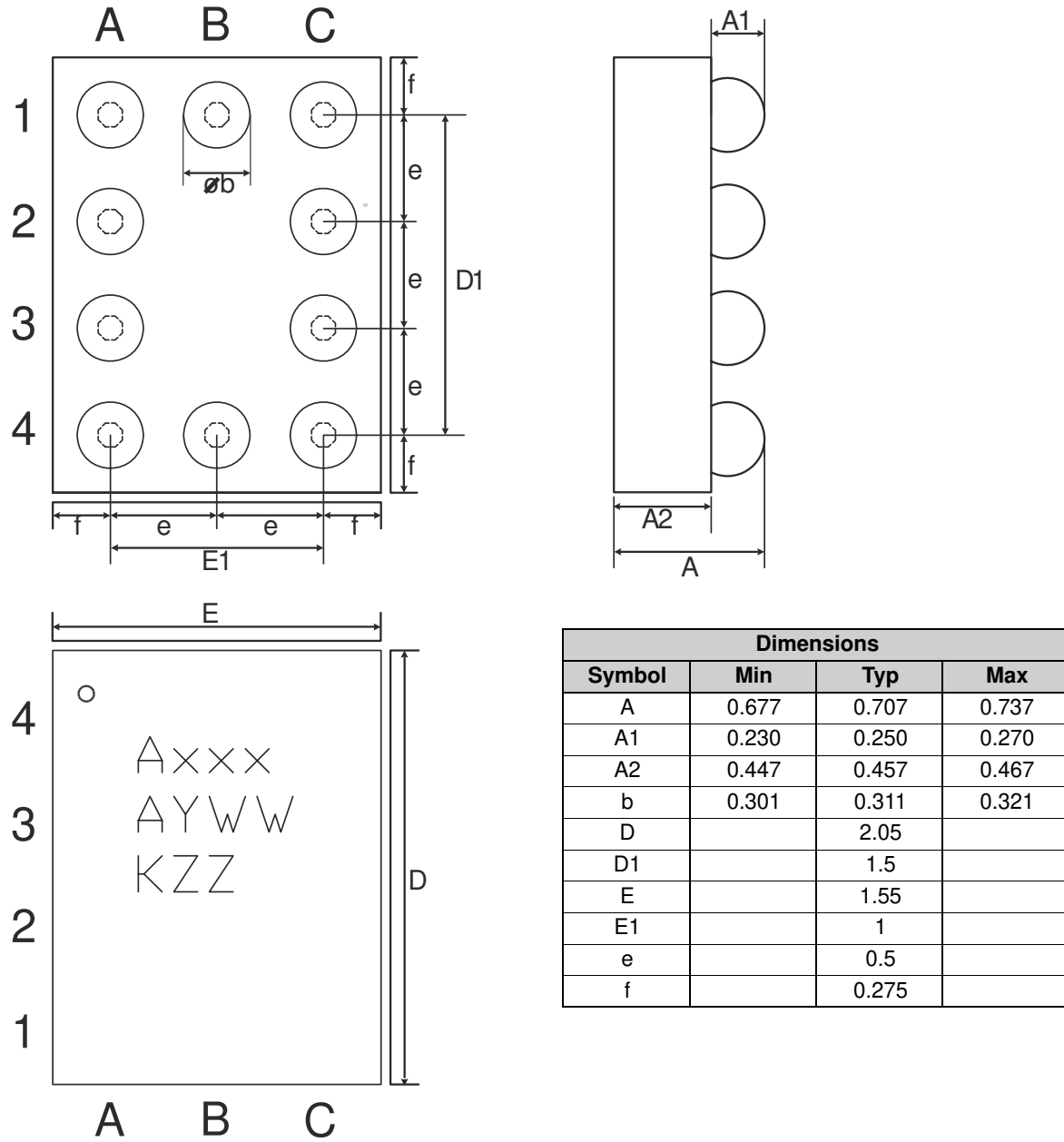

11 Ordering Information

The device is available as the standard products shown in [Table 4](#).

Table 4. Ordering Information

Ordering Code	Marking	Description	Delivery Form	Package
AS1746-BTDR	ASK8	0.5/0.6Ω, Low-Voltage, Dual SPDT Analog Switch	Tray	TDFN-10 (3x3mm)
AS1746-BTDT	ASK8	0.5/0.6Ω, Low-Voltage, Dual SPDT Analog Switch	Tape and Reel	TDFN-10 (3x3mm)
AS1746-BWLT*	ASK7	0.5/0.6Ω, Low-Voltage, Dual SPDT Analog Switch	Tape and Reel	WL-CSP-10

* Available on request.

Note: All products are RoHS compliant and Pb-free.

Buy our products or get free samples online at ICdirect: <http://www.austriamicrosystems.com/ICdirect>

For further information and requests, please contact us <mailto:sales@austriamicrosystems.com>
or find your local distributor at <http://www.austriamicrosystems.com/distributor>

Copyrights

Copyright © 1997-2009, austriamicrosystems AG, Tobelbaderstrasse 30, 8141 Unterpremstaetten, Austria-Europe. Trademarks Registered ®. All rights reserved. The material herein may not be reproduced, adapted, merged, translated, stored, or used without the prior written consent of the copyright owner.

All products and companies mentioned are trademarks or registered trademarks of their respective companies.

Disclaimer

Devices sold by austriamicrosystems AG are covered by the warranty and patent indemnification provisions appearing in its Term of Sale. austriamicrosystems AG makes no warranty, express, statutory, implied, or by description regarding the information set forth herein or regarding the freedom of the described devices from patent infringement. austriamicrosystems AG reserves the right to change specifications and prices at any time and without notice. Therefore, prior to designing this product into a system, it is necessary to check with austriamicrosystems AG for current information. This product is intended for use in normal commercial applications. Applications requiring extended temperature range, unusual environmental requirements, or high reliability applications, such as military, medical life-support or life-sustaining equipment are specifically not recommended without additional processing by austriamicrosystems AG for each application. For shipments of less than 100 parts the manufacturing flow might show deviations from the standard production flow, such as test flow or test location.

The information furnished here by austriamicrosystems AG is believed to be correct and accurate. However, austriamicrosystems AG shall not be liable to recipient or any third party for any damages, including but not limited to personal injury, property damage, loss of profits, loss of use, interruption of business or indirect, special, incidental or consequential damages, of any kind, in connection with or arising out of the furnishing, performance or use of the technical data herein. No obligation or liability to recipient or any third party shall arise or flow out of austriamicrosystems AG rendering of technical or other services.



Contact Information

Headquarters

austriamicrosystems AG
Tobelbaderstrasse 30
A-8141 Unterpremstaetten, Austria

Tel: +43 (0) 3136 500 0
Fax: +43 (0) 3136 525 01

For Sales Offices, Distributors and Representatives, please visit:

<http://www.austriamicrosystems.com/contact>