



Chipsmall Limited consists of a professional team with an average of over 10 year of expertise in the distribution of electronic components. Based in Hongkong, we have already established firm and mutual-benefit business relationships with customers from,Europe,America and south Asia,supplying obsolete and hard-to-find components to meet their specific needs.

With the principle of “Quality Parts,Customers Priority,Honest Operation,and Considerate Service”,our business mainly focus on the distribution of electronic components. Line cards we deal with include Microchip,ALPS,ROHM,Xilinx,Pulse,ON,Everlight and Freescale. Main products comprise IC,Modules,Potentiometer,IC Socket,Relay,Connector.Our parts cover such applications as commercial,industrial, and automotives areas.

We are looking forward to setting up business relationship with you and hope to provide you with the best service and solution. Let us make a better world for our industry!



Contact us

Tel: +86-755-8981 8866 Fax: +86-755-8427 6832

Email & Skype: info@chipsmall.com Web: www.chipsmall.com

Address: A1208, Overseas Decoration Building, #122 Zhenhua RD., Futian, Shenzhen, China



DATA SHEET

AS218-321, AS218-321LF: PHEMT GaAs IC High-Power Transfer Switch 0.1–6 GHz

Applications

- WLAN 802.11a, b, g diversity

Features

- Operating frequency 0.1–6 GHz
- Positive low voltage control (0/3 V operation)
- Low insertion loss
- Available lead (Pb)-free and RoHS-compliant MSL-1 @ 250 °C per JEDEC J-STD-020

Description

The AS218-321 is a broadband transfer switch designed to combine T/R and antenna diversity switching functions on a single IC. The device is designed to handle high power and maintain high linearity at low control voltages. This low-cost switch is ideal for Wi-Fi systems and is capable of covering both the 2.4 and 5 GHz bands.

Pin Out (Top View)

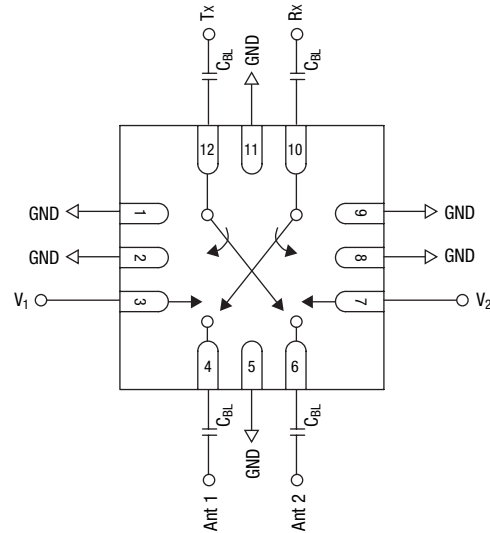

DC blocking capacitors (C_{BL}) required on RF ports.
 $C_{BL} = 15 \text{ pF}$.

NEW Skyworks offers lead (Pb)-free, RoHS (Restriction of Hazardous Substances)-compliant packaging.



Electrical Specifications at 25 °C (0, 3 V)

Parameter ^(1, 4)	Condition	Frequency	Min.	Typ.	Max.	Unit
Insertion loss ⁽²⁾	Ant 1, Ant 2 to Tx, Rx	0.10–6.00 GHz		1.6	1.8	dB
		2.40–2.50 GHz		1.2	1.4	dB
		5.15–5.85 GHz		1.4	1.6	dB
Isolation	Ant 1, Ant 2 to Tx, Rx	0.10–6.00 GHz	17	19		dB
		2.40–2.50 GHz	26	28		dB
		5.15–5.85 GHz	17	19		dB
Return loss ⁽³⁾	Ant 1, Ant 2 to Tx, Rx	0.10–6.00 GHz		10		dB
		2.40–2.50 GHz		15		dB
		5.15–5.85 GHz		20		dB

1. All measurements made in a 50 Ω system.
 2. Insertion loss changes by 0.003 dB/C.

3. Return loss for insertion loss state.
 4. Tx and Rx paths can be used interchangeably.

Operating Characteristics at 25 °C (0, 3 V)

Parameter	Condition	Frequency	Min.	Typ.	Max.	Unit
2nd and 3rd harmonic	23 dBm input @ 0,3 V	2–6 GHz		63		dBc
P_1 dB		2–6 GHz		33		dBm
IIP3	20 dBm per tone 22 dBm per tone	2–3 GHz 5–6 GHz		54 47		dBm
Thermal resistance				25		°C/W
Control voltages	$V_{LOW} = 0-0.2 V @ 20 \mu A \text{ max.}$ $V_{HIGH} = 3-5 V @ 200 \mu A \text{ max.}$					

Typical Performance Data (0, +3 V)

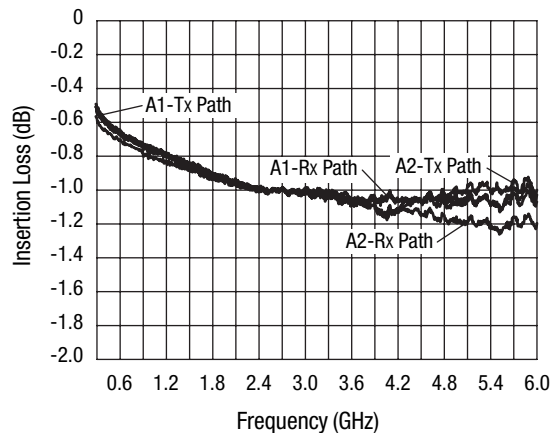

Insertion Loss vs. Frequency

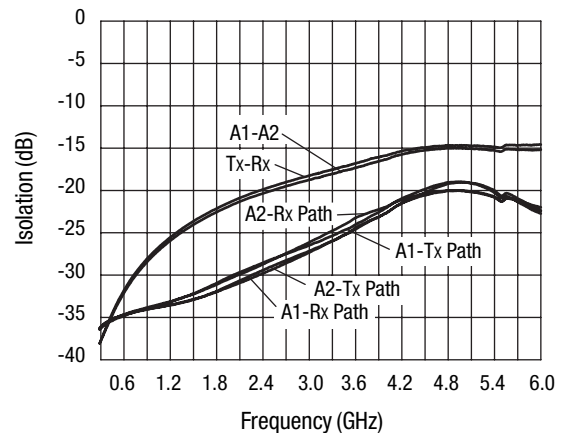

Isolation vs. Frequency

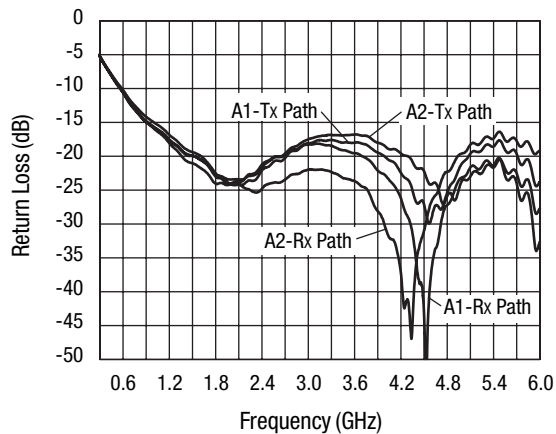

Return Loss vs. Frequency

Absolute Maximum Ratings

Characteristic	Value
RF input power	35 dBm > 500 MHz 0/7 V control
Control voltage	-0.2 V, +8 V
Operating temperature	-40 °C to +85 °C
Storage temperature	-65 °C to +150 °C

Performance is guaranteed only under the conditions listed in the specifications table and is not guaranteed under the full range(s) described by the Absolute Maximum specifications. Exceeding any of the absolute maximum/minimum specifications may result in permanent damage to the device and will void the warranty.

CAUTION: Although this device is designed to be as robust as possible, ESD (Electrostatic Discharge) can damage this device. This device must be protected at all times from ESD. Static charges may easily produce potentials of several kilovolts on the human body or equipment, which can discharge without detection. Industry-standard ESD precautions must be employed at all times.

Truth Table

V ₁	V ₂	Insertion Loss Path
0	1	Ant 1 to Tx, Ant 2 to Rx
1	0	Ant 2 to Tx, Ant 1 to Rx
0	0	Allowed but not recommended
1	1	Allowed but not recommended

"1" = 3 to 5 V.
 "0" = 0 to 0.2 V.

Recommended Solder Reflow Profiles

Refer to the ["Recommended Solder Reflow Profile"](#)

Application Note.

Tape and Reel Information

Refer to the ["Discrete Devices and IC Switch/Attenuators Tape and Reel Package Orientation"](#) Application Note.

QFN-12

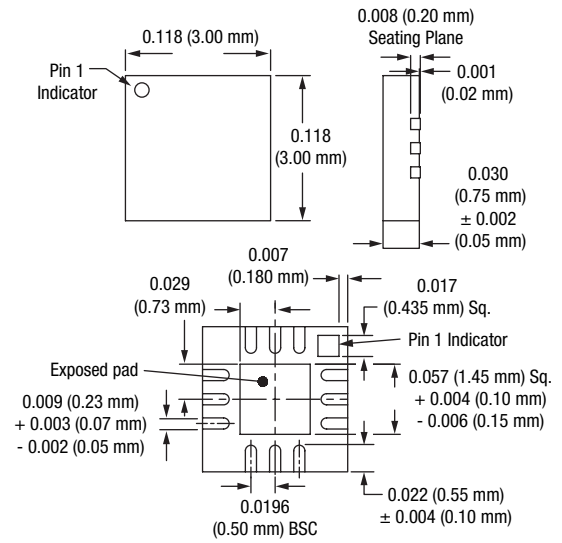

Copyright © 2002, 2003, 2004, 2005, 2006, Skyworks Solutions, Inc. All Rights Reserved.

Information in this document is provided in connection with Skyworks Solutions, Inc. ("Skyworks") products or services. These materials, including the information contained herein, are provided by Skyworks as a service to its customers and may be used for informational purposes only by the customer. Skyworks assumes no responsibility for errors or omissions in these materials or the information contained herein. Skyworks may change its documentation, products, services, specifications or product descriptions at any time, without notice. Skyworks makes no commitment to update the materials or information and shall have no responsibility whatsoever for conflicts, incompatibilities, or other difficulties arising from any future changes.

No license, whether express, implied, by estoppel or otherwise, is granted to any intellectual property rights by this document. Skyworks assumes no liability for any materials, products or information provided hereunder, including the sale, distribution, reproduction or use of Skyworks products, information or materials, except as may be provided in Skyworks Terms and Conditions of Sale.

THE MATERIALS, PRODUCTS AND INFORMATION ARE PROVIDED "AS IS" WITHOUT WARRANTY OF ANY KIND, WHETHER EXPRESS, IMPLIED, STATUTORY, OR OTHERWISE, INCLUDING FITNESS FOR A PARTICULAR PURPOSE OR USE, MERCHANTABILITY, PERFORMANCE, QUALITY OR NON-INFRINGEMENT OF ANY INTELLECTUAL PROPERTY RIGHT; ALL SUCH WARRANTIES ARE HEREBY EXPRESSLY DISCLAIMED. SKYWORKS DOES NOT WARRANT THE ACCURACY OR COMPLETENESS OF THE INFORMATION, TEXT, GRAPHICS OR OTHER ITEMS CONTAINED WITHIN THESE MATERIALS. SKYWORKS SHALL NOT BE LIABLE FOR ANY DAMAGES, INCLUDING BUT NOT LIMITED TO ANY SPECIAL, INDIRECT, INCIDENTAL, STATUTORY, OR CONSEQUENTIAL DAMAGES, INCLUDING WITHOUT LIMITATION, LOST REVENUES OR LOST PROFITS THAT MAY RESULT FROM THE USE OF THE MATERIALS OR INFORMATION, WHETHER OR NOT THE RECIPIENT OF MATERIALS HAS BEEN ADVISED OF THE POSSIBILITY OF SUCH DAMAGE.

Skyworks products are not intended for use in medical, lifesaving or life-sustaining applications, or other equipment in which the failure of the Skyworks products could lead to personal injury, death, physical or environmental damage. Skyworks customers using or selling Skyworks products for use in such applications do so at their own risk and agree to fully indemnify Skyworks for any damages resulting from such improper use or sale.

Customers are responsible for their products and applications using Skyworks products, which may deviate from published specifications as a result of design defects, errors, or operation of products outside of published parameters or design specifications. Customers should include design and operating safeguards to minimize these and other risks. Skyworks assumes no liability for applications assistance, customer product design, or damage to any equipment resulting from the use of Skyworks products outside of stated published specifications or parameters.

Skyworks, the Skyworks symbol, and "Breakthrough Simplicity" are trademarks or registered trademarks of Skyworks Solutions, Inc., in the United States and other countries. Third-party brands and names are for identification purposes only, and are the property of their respective owners. Additional information, including relevant terms and conditions, posted at www.skyworksinc.com, are incorporated by reference.