



Chipsmall Limited consists of a professional team with an average of over 10 year of expertise in the distribution of electronic components. Based in Hongkong, we have already established firm and mutual-benefit business relationships with customers from,Europe,America and south Asia,supplying obsolete and hard-to-find components to meet their specific needs.

With the principle of “Quality Parts,Customers Priority,Honest Operation,and Considerate Service”,our business mainly focus on the distribution of electronic components. Line cards we deal with include Microchip,ALPS,ROHM,Xilinx,Pulse,ON,Everlight and Freescale. Main products comprise IC,Modules,Potentiometer,IC Socket,Relay,Connector.Our parts cover such applications as commercial,industrial, and automotives areas.

We are looking forward to setting up business relationship with you and hope to provide you with the best service and solution. Let us make a better world for our industry!



Contact us

Tel: +86-755-8981 8866 Fax: +86-755-8427 6832

Email & Skype: info@chipsmall.com Web: www.chipsmall.com

Address: A1208, Overseas Decoration Building, #122 Zhenhua RD., Futian, Shenzhen, China



LOW POWER LOW OFFSET VOLTAGE SINGLE COMPARATOR**AS331****General Description**

The AS331 consists of a single precision voltage comparator with a typical input offset voltage of 1.0mV and high voltage gain. It is specifically designed to operate from a single power supply over wide range of voltages. Operation from split power supply is also possible and the low power supply current drain is independent of the magnitude of the power supply voltage.

The AS331 is available in standard SOT-23-5 package.

Features

- Wide Supply Voltage Range
 - Single Supply: 2V to 36V
 - Dual Supplies: $\pm 1V$ to $\pm 18V$
- Low Supply Current at $V_{CC}=5V$: 0.4mA
- Low Input Bias Current: 25nA (Typical)
- Low Input Offset Current: 5nA (Typical)
- Low Input Offset Voltage: 1mV (Typical)
- Input Common Mode Voltage Range Includes Ground
- Differential Input Voltage Range Equals to the Power Supply Voltage
- Low Output Saturation Voltage at 4mA: 200mV (Typical)
- Open Collector Output

Applications

- Battery Charger
- Cordless Telephone
- Switching Power Supply
- DC-DC Module
- PC Motherboard
- Communication Equipment

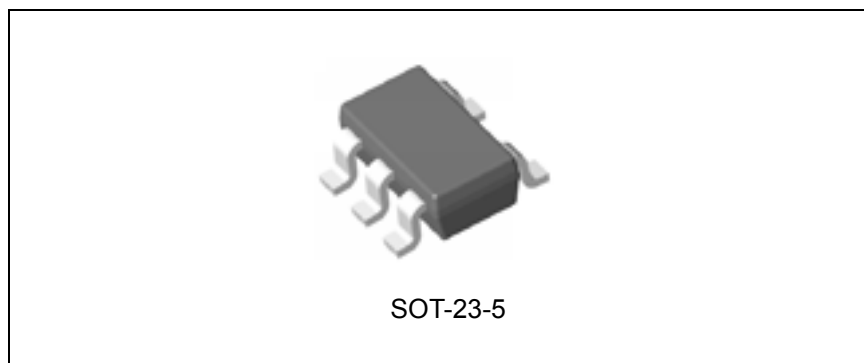


Figure 1. Package Type of AS331

LOW POWER LOW OFFSET VOLTAGE SINGLE COMPARATOR AS331

Pin Configuration

K Package
(SOT-23-5)

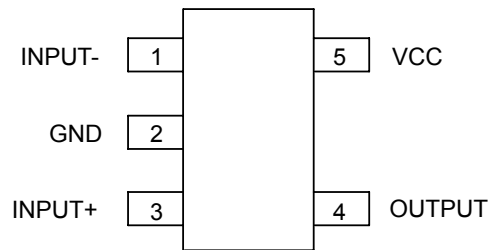


Figure 2. Pin Configuration of AS331 (Top View)

Functional Block Diagram

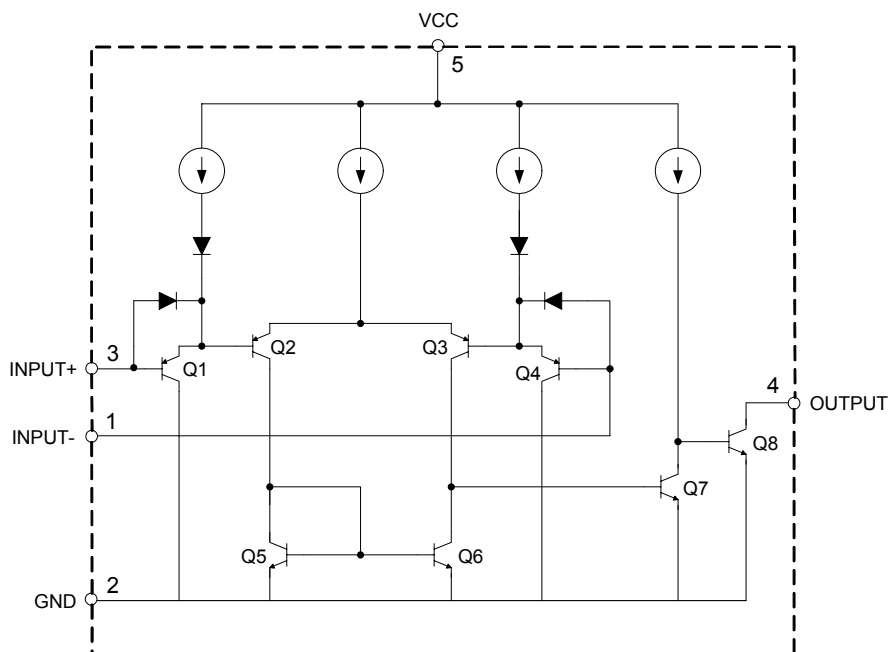
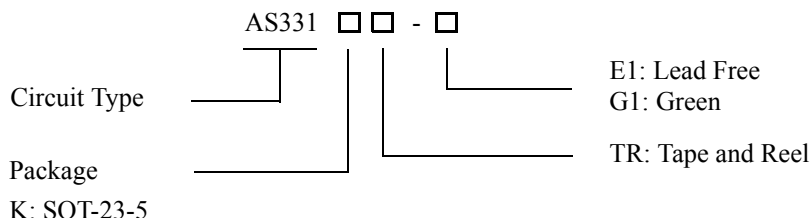


Figure 3. Functional Block Diagram of AS331



LOW POWER LOW OFFSET VOLTAGE SINGLE COMPARATOR AS331

Ordering Information



Package	Temperature Range	Part Number		Marking ID		Packing Type
		Lead Free	Green	Lead Free	Green	
SOT-23-5	-40 to 85°C	AS331KTR-E1	AS331KTR-G1	EEA	GEA	Tape & Reel

BCD Semiconductor's Pb-free products, as designated with "E1" suffix in the part number, are RoHS compliant. Products with "G1" suffix are available in green package.

Absolute Maximum Ratings (Note 1)

Parameter	Symbol	Value	Unit
Supply Voltage	V _{CC}	40	V
Differential Input Voltage	V _{ID}	40	V
Input Voltage	V _{IN}	-0.3 to 40	V
Input Current (V _{IN} <-0.3V) (Note 2)	I _{IN}	50	mA
Output Short-circuit Current to Ground		Continuous	
Power Dissipation (T _A =25°C)	P _D	620	mW
Operating Junction Temperature	T _J	150	°C
Storage Temperature	T _{STG}	-65 to 150	°C
Lead Temperature (Soldering, 10sec)	T _{LEAD}	260	°C

Note 1: Stresses greater than those listed under "Absolute Maximum Ratings" may cause permanent damage to the device. These are stress ratings only, and functional operation of the device at these or any other conditions beyond those indicated under "Recommended Operating Conditions" is not implied. Exposure to "Absolute Maximum Ratings" for extended periods may affect device reliability.

Note 2: This input current will only exist when the voltage at any of the input leads is driven negative. It is due to the collector-base junction of the input PNP transistors becoming forward biased and thereby acting as input diode clamps. In addition to this diode action, there is also lateral NPN parasitic transistor action on the IC chip. This transistor action can cause the output voltages of the comparators to go to the V+ voltage level (or to ground for a large overdrive) for the time duration that an input is driven negative. This is not destructive and normal output states will re-establish when the input voltage, which was negative, again returns to a value greater than -0.3V (at 25°C).



LOW POWER LOW OFFSET VOLTAGE SINGLE COMPARATOR AS331

Recommended Operating Conditions

Parameter	Symbol	Min	Max	Unit
Supply Voltage	V_{CC}	2	36	V
Operating Ambient Temperature Range	T_A	-40	85	°C

Electrical Characteristics

$V_{CC}=5V$, $GND=0V$, $T_A=25^{\circ}C$, unless otherwise specified. **Bold** typeface applies over $T_A=-40$ to $85^{\circ}C$ (Note 3)

Parameter	Symbol	Conditions	Min	Typ	Max	Unit	
Input Offset Voltage	V_{OS}	$V_{OUT}=1.4V$, $V_{CC}=5$ to $30V$		1	5	mV	
					7.0		
Input Bias Current	I_B	I_{IN+} or I_{IN-} with output in linear range, $V_{CM}=0V$		25	250	nA	
					400		
Input Offset Current	I_{IO}	$I_{IN+}-I_{IN-}$, $V_{CM}=0V$		5	50	nA	
					200		
Input Common Mode Voltage Range (Note 4)		$V_{CC}=30V$	0		$V_{CC}-1.5$	V	
Supply Current	I_{CC}	$R_L=\infty$	$V_{CC}=5V$		0.4	1.0	mA
						2.0	
				$V_{CC}=30V$		0.5	
						3.0	
Voltage Gain	G_V	$V_{CC}=15V$, $R_L \geq 15k\Omega$, $V_{OUT}=1$ to $11V$	50	200		V/mV	
Large Signal Response Time		$V_{IN}=\text{TTL Logic Swing}$, $R_L=5.1k\Omega$		200		ns	
Response Time		$R_L=5.1k\Omega$		1.3		μs	
Output Sink Current	I_{SINK}	$V_{IN-}=1V$, $V_{IN+}=0V$, $V_{OUT}=1.5V$	6.0	16		mA	
Output Leakage Current	I_{LEAK}	$V_{IN-}=0V$, $V_{IN+}=1V$, $V_{OUT}=5V$		0.1		nA	
		$V_{IN-}=0V$, $V_{IN+}=1V$, $V_{OUT}=30V$			1	μA	
Saturation Voltage	V_{SAT}	$V_{IN-}=1V$, $V_{IN+}=0V$, $I_{SINK} \leq 4mA$		200	400	mV	
					500		

Note 3: These specifications are limited to $-40^{\circ}C \leq T_A \leq 85^{\circ}C$. Limits over temperature are guaranteed by design, but not tested in production.

Note 4: The input common mode voltage of either input signal voltage should not be allowed to go negatively by more than 0.3V (at 25°C). The upper end of the common mode voltage range is $V_{CC}-1.5V$ (at 25°C), but either or both inputs can go to +36V without damages, independent of the magnitude of the V_{CC} .



LOW POWER LOW OFFSET VOLTAGE SINGLE COMPARATOR

AS331

Typical Performance Characteristics

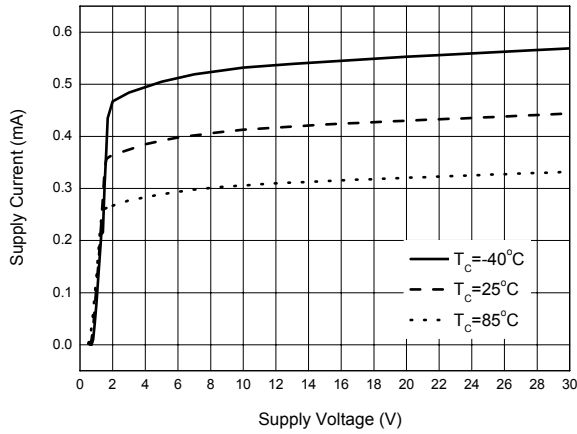


Figure 4. Supply Current vs. Supply Voltage

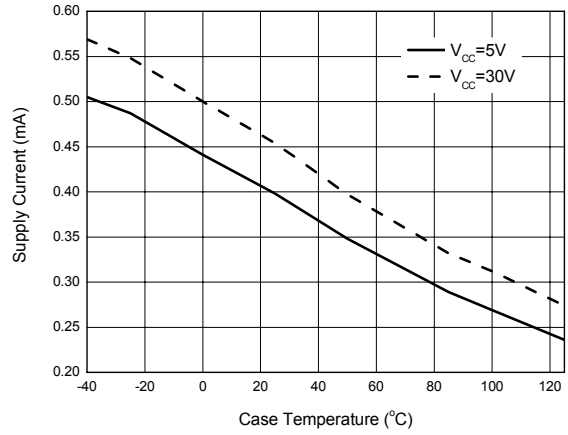


Figure 5. Supply Current vs. Case Temperature

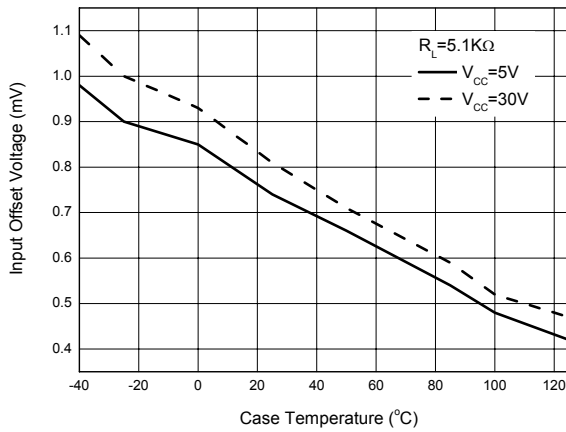


Figure 6. Input Offset Voltage vs. Case Temperature

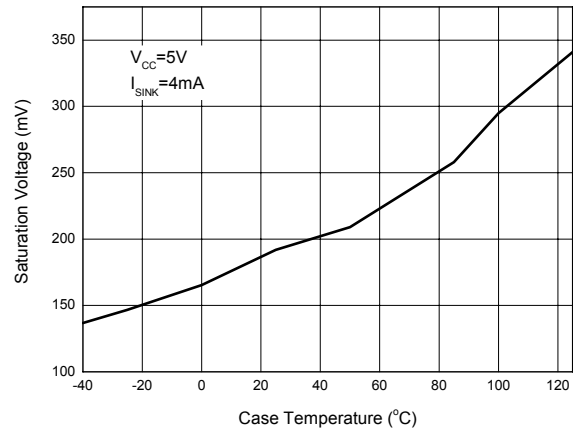


Figure 7. Saturation Voltage vs. Case Temperature



LOW POWER LOW OFFSET VOLTAGE SINGLE COMPARATOR

AS331

Typical Performance Characteristics (Continued)

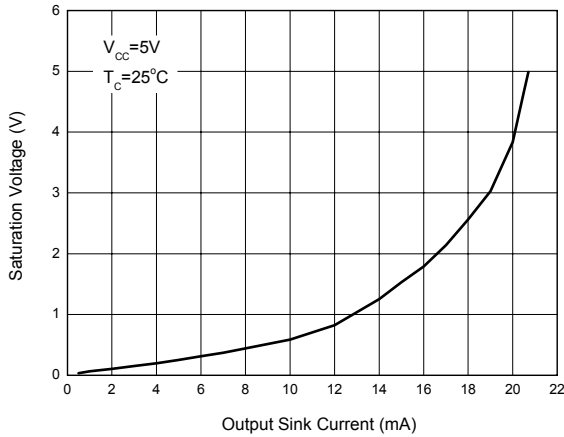


Figure 8. Saturation Voltage vs. Output Sink Current

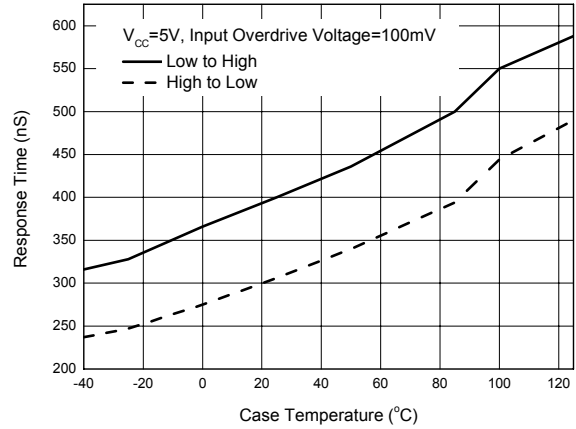


Figure 9. Response Time vs. Case Temperature

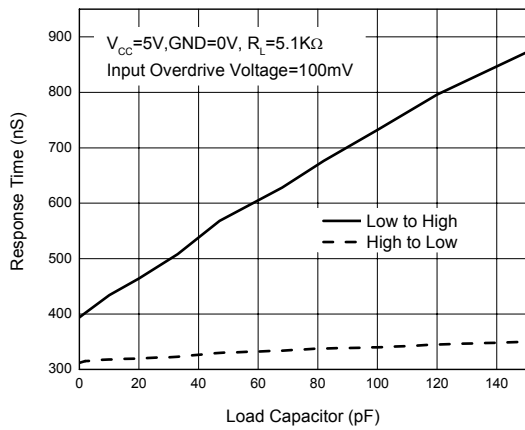


Figure 10. Response Time vs. Load Capacitor

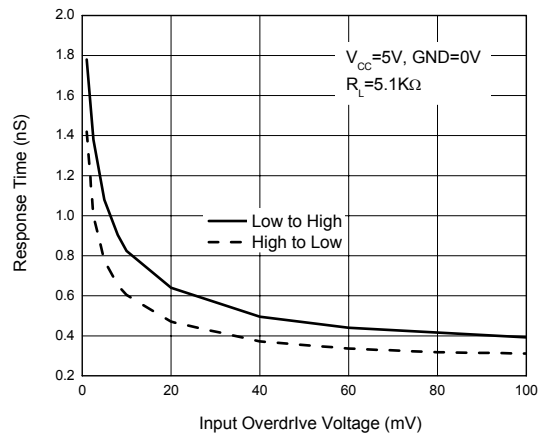


Figure 11. Response Time vs. Input Overdrive Voltage



LOW POWER LOW OFFSET VOLTAGE SINGLE COMPARATOR

AS331

Typical Performance Characteristics (Continued)

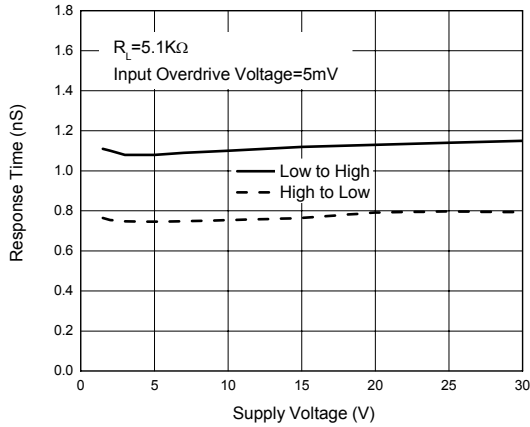


Figure 12. Response Time vs. Supply Voltage

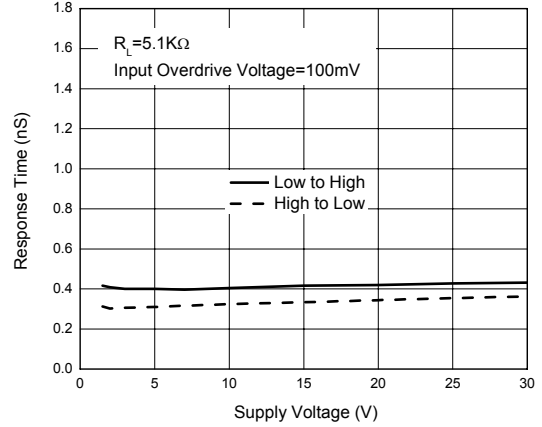


Figure 13. Response Time vs. Supply Voltage

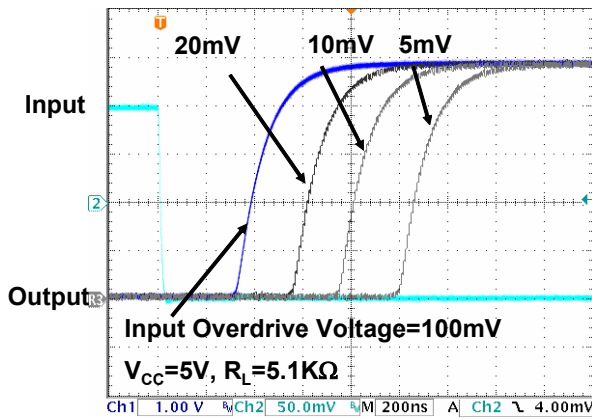


Figure 14. Response Time for Positive Transition

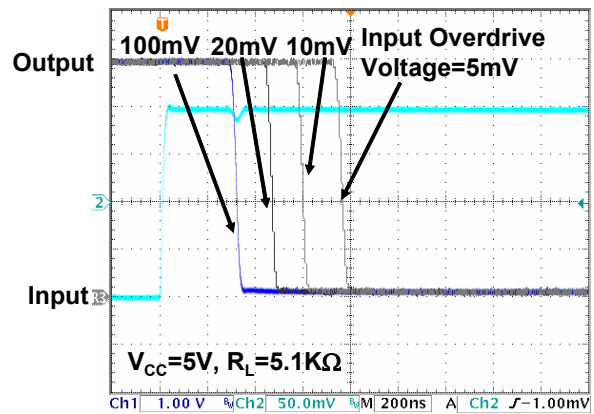


Figure 15. Response Time for Negative Transition

Typical Performance Characteristics (Continued)

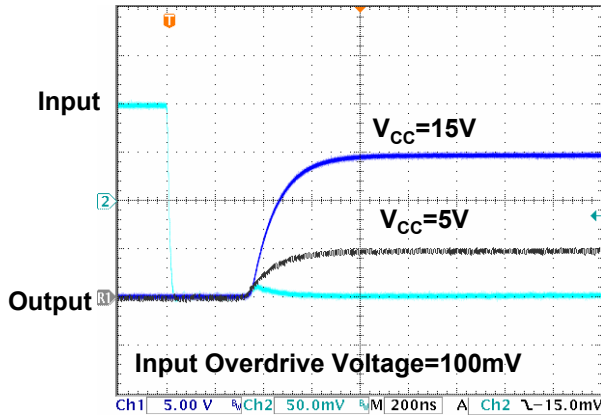


Figure 16. Response Time for Positive Transition

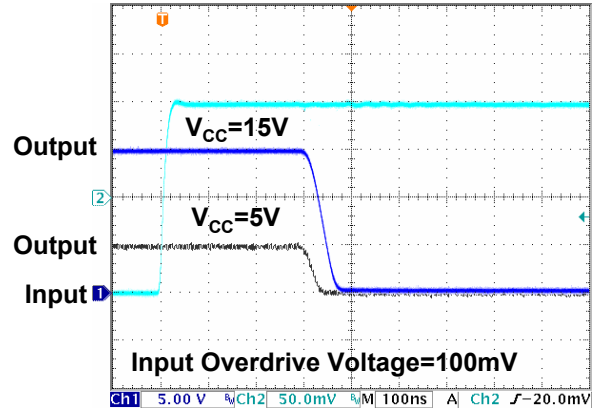


Figure 17. Response Time for Negative Transition

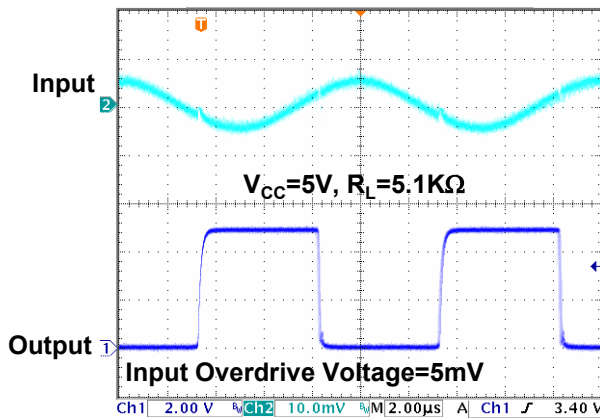


Figure 18. 100kHz Response

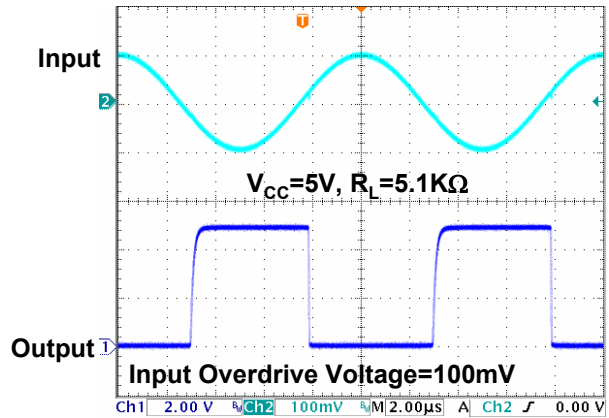


Figure 19. 100kHz Response

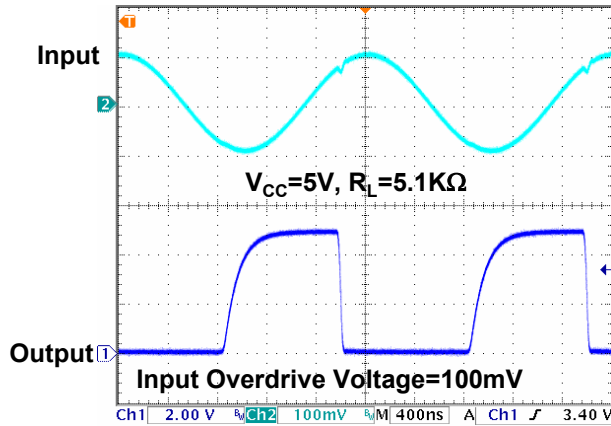
Typical Performance Characteristics (Continued)

Figure 20. 500kHz Response

Typical Application

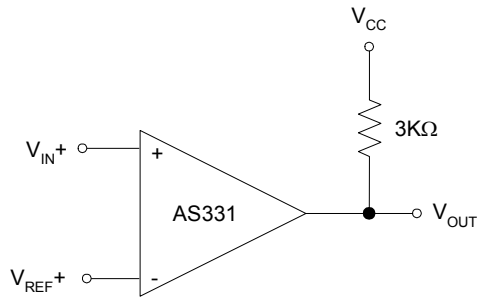


Figure 21. Basic Comparator

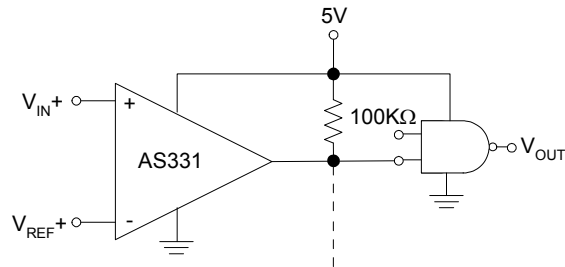


Figure 22. Driving CMOS

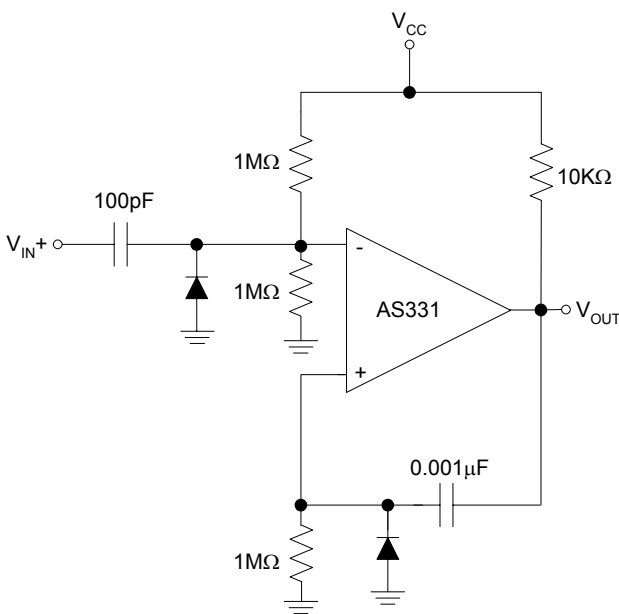


Figure 23. One Shot Multivibrator

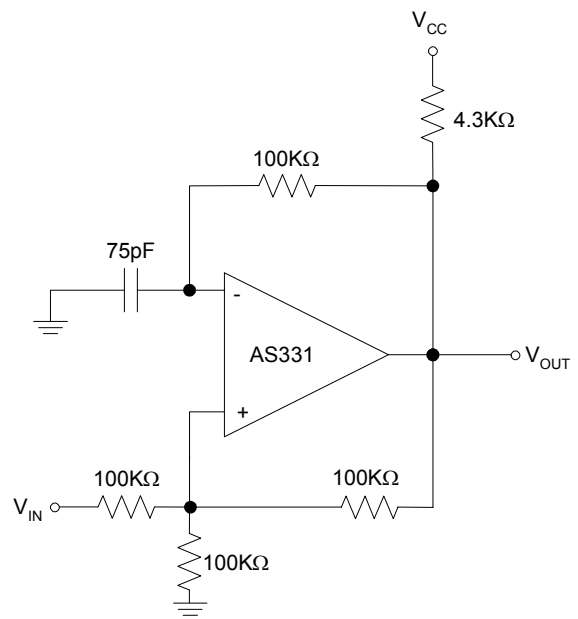


Figure 24. Squarewave Oscillator

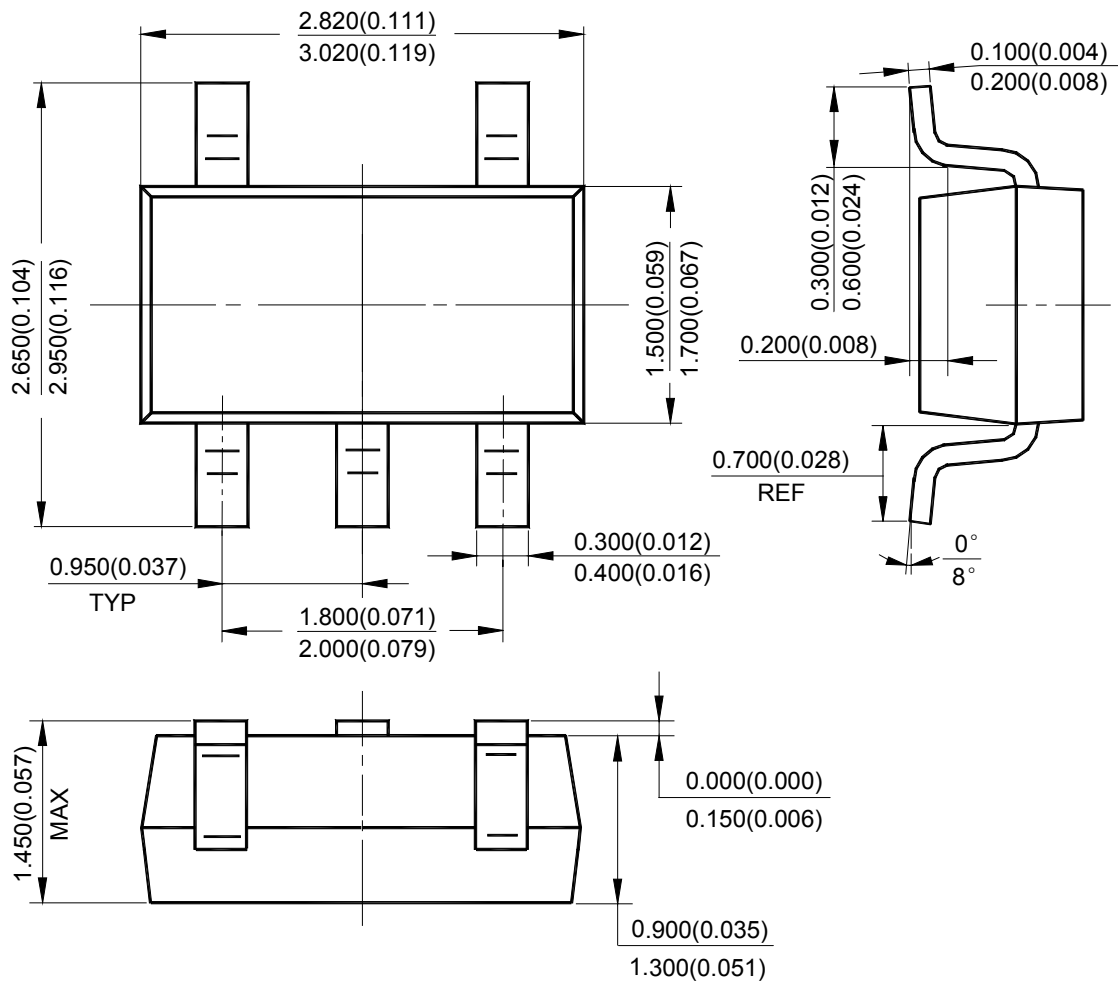


LOW POWER LOW OFFSET VOLTAGE SINGLE COMPARATOR **AS331**

Mechanical Dimensions

SOT-23-5

Unit: mm(inch)





BCD Semiconductor Manufacturing Limited

<http://www.bcdsemi.com>

IMPORTANT NOTICE

BCD Semiconductor Manufacturing Limited reserves the right to make changes without further notice to any products or specifications herein. BCD Semiconductor Manufacturing Limited does not assume any responsibility for use of any its products for any particular purpose, nor does BCD Semiconductor Manufacturing Limited assume any liability arising out of the application or use of any its products or circuits. BCD Semiconductor Manufacturing Limited does not convey any license under its patent rights or other rights nor the rights of others.

MAIN SITE

- Headquarters

BCD Semiconductor Manufacturing Limited

No. 1600, Zi Xing Road, Shanghai Zizhu Science-based Industrial Park, 200241, China
Tel: +86-21-24162266, Fax: +86-21-24162277

- Wafer Fab

Shanghai SIM-BCD Semiconductor Manufacturing Co., Ltd.

800 Yi Shan Road, Shanghai 200233, China
Tel: +86-21-6485 1491, Fax: +86-21-5450 0008

REGIONAL SALES OFFICE

Shenzhen Office

Shanghai SIM-BCD Semiconductor Manufacturing Co., Ltd., Shenzhen Office

Unit A Room 1203, Skyworth Bldg., Gaoxin Ave. 1.S., Nanshan District, Shenzhen, China
Tel: +86-755-8826 7951
Fax: +86-755-8826 7865

Taiwan Office

BCD Semiconductor (Taiwan) Company Limited

4F, 298-1, Rui Guang Road, Nei-Hu District, Taipei, Taiwan
Tel: +886-2-2656 2808
Fax: +886-2-2656 2806

USA Office

BCD Semiconductor Corp.

30920 Huntwood Ave. Hayward, CA 94544, USA
Tel : +1-510-324-2988
Fax: +1-510-324-2788