



Chipsmall Limited consists of a professional team with an average of over 10 year of expertise in the distribution of electronic components. Based in Hongkong, we have already established firm and mutual-benefit business relationships with customers from,Europe,America and south Asia,supplying obsolete and hard-to-find components to meet their specific needs.

With the principle of “Quality Parts,Customers Priority,Honest Operation,and Considerate Service”,our business mainly focus on the distribution of electronic components. Line cards we deal with include Microchip,ALPS,ROHM,Xilinx,Pulse,ON,Everlight and Freescale. Main products comprise IC,Modules,Potentiometer,IC Socket,Relay,Connector.Our parts cover such applications as commercial,industrial, and automotives areas.

We are looking forward to setting up business relationship with you and hope to provide you with the best service and solution. Let us make a better world for our industry!



Contact us

Tel: +86-755-8981 8866 Fax: +86-755-8427 6832

Email & Skype: info@chipsmall.com Web: www.chipsmall.com

Address: A1208, Overseas Decoration Building, #122 Zhenhua RD., Futian, Shenzhen, China



AS3500 AS3501 AS3502

Low Power Ambient Noise-Cancelling Speaker Driver

Data Sheet

1 General Description

The AS3500/01/02 are speaker driver with Ambient Noise Cancelling function for handsets, headphones or ear pieces. It is intended to improve quality of e.g. music listening, a phone conversation etc. by reducing background ambient noise.

The fully analog implementation allows the lowest power consumption, lowest system BOM cost and most natural received voice enhancement otherwise difficult to achieve with DSP implementations. The device is designed to be easily applied to existing architectures.

An internal OTP-ROM can be optionally used to store the microphones gain calibration settings.

The AS3500/01/02 can be used in different configurations for best trade-off of noise cancellation, required filtering functions and mechanical designs.

The simpler feed-forward topology is used to effectively reduce low frequency background noise. The feed-back topology with either 1 or 2 filtering stages can be used to reduce noise for a larger frequency range, and to even implement transfer functions like speaker equalization, Baxandall equalization, high/low shelving filter and to set a predefined loop bandwidth.

The filter loop is optimized by the user for specific handset electrical and mechanical designs by dimensioning simple R, C components.

Most handset implementations will make use of a single noise detecting microphone. Two microphones could be used to allow for increased flexibility of their location in the handset mechanical design. Using the bridged mode allows to even drive high impedance headsets.

2 Key Features

Microphone Input

- 128 gain steps @0.375dB and MUTE with AGC
- differential, low noise microphone amplifier
- single ended or differential mode
- supply for electret microphone
- MIC gain OTP programmable

High Efficiency Headphone Amplifier

- 2x34mW, 0.1% THD @ 16Ω, 1.5V supply, 100dB SNR
- bridged mode for e.g. 300Ω loads
- click and pop less start-up and mode switching

Line Input

- volume control via serial interface or volume pin
- 64 steps @ 0.75dB and MUTE, pop-free gain setting
- single ended stereo or mono differential mode

ANC processing

- feed-forward cancellation
- feed-back cancellation with filter loop transfer function definable via simple RC components
- simple in production SW calibration
- 12-30dB noise reduction (headset dependent)
- 10-2000Hz wide frequency active noise attenuation (headset dependent)

Monitor Function

- for assisted hearing, i.e. to monitor announcements
- fixed (OTP prog.) ambient sound amplification to compensate headphone passive attenuation
- volume controlled ambient sound amplification mixed with fixed (OTP prog.) attenuation of LineIn

Incremental Functions

- ANC with or without music on the receiving path
- improved dynamic range playback
- simple and low cost single noise detection microphone implementation
- OTP ROM for automatic trimming during production

Performance Parameter

- 5/3.8mA @ 1.5V stereo/mono ANC; <1uA quiescent
- extended PSRR for 217Hz

Interfaces

- 2 wire serial control mode & volume inputs
- calibration via Line-In or 2-wire serial interface
- single cell or fixed 1.0-1.8V supply with internal CP

Package

- AS3500, AS3501 QFN24 [4x4mm] 0.5mm pitch
- AS3502 QFN32 [5.x5mm] 0.5mm pitch

3 Applications

Ear pieces, Headsets, Hands-Free Kits, Mobile Phones, Voice Communicating Devices

Figure 1. AS3501 Feed Forward ANC Block Diagram

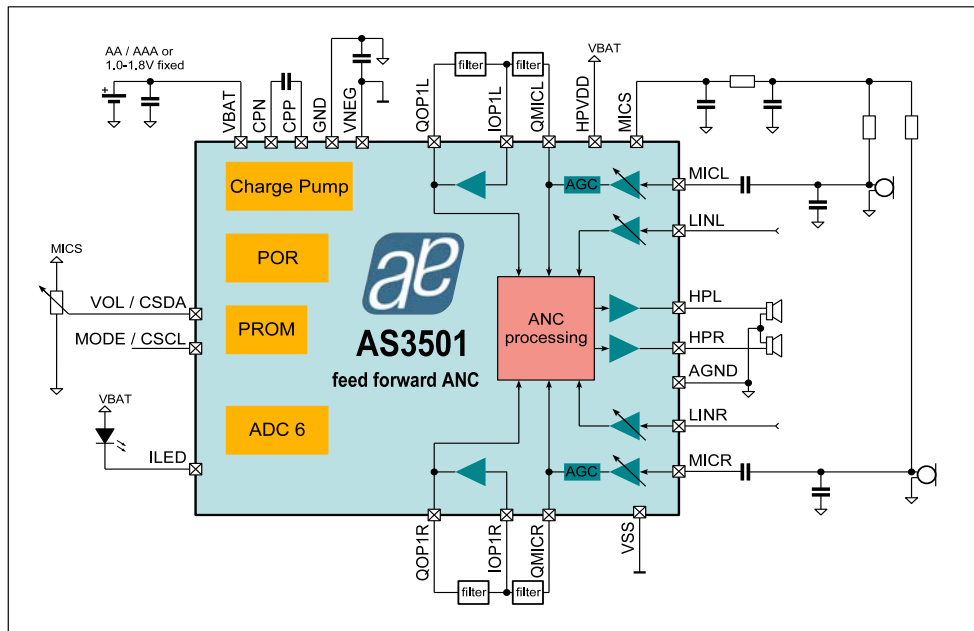

Figure 2. AS3502 Feed-Back Block Diagram

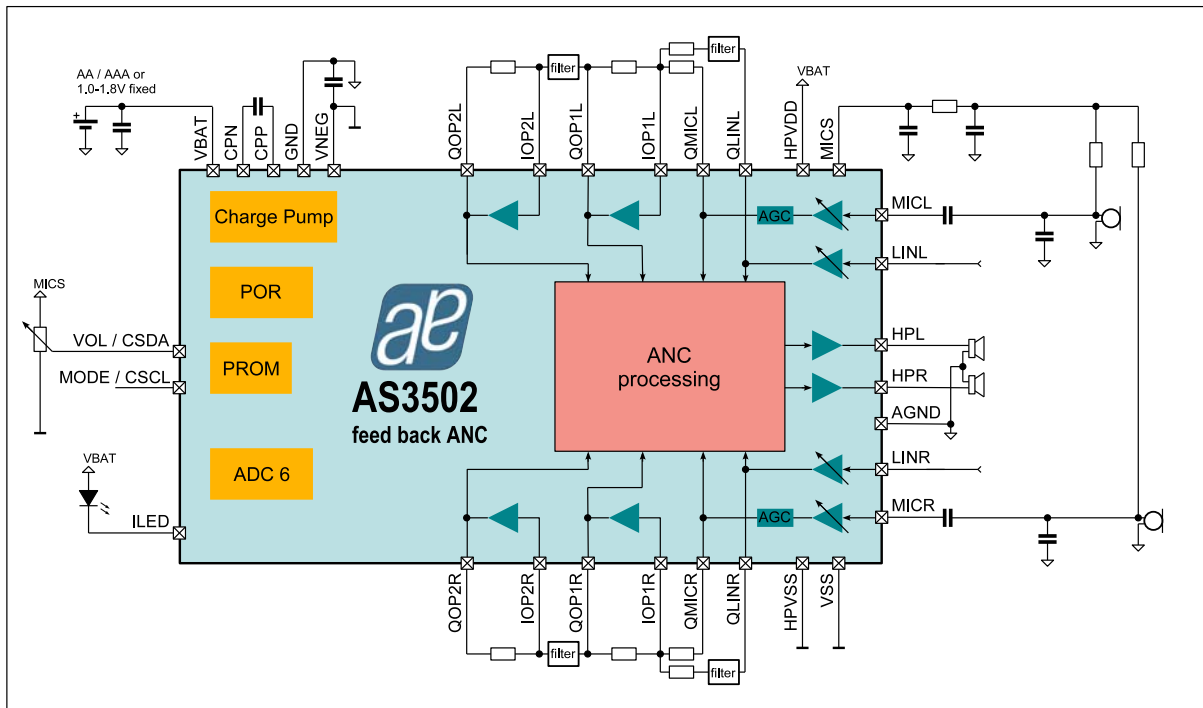
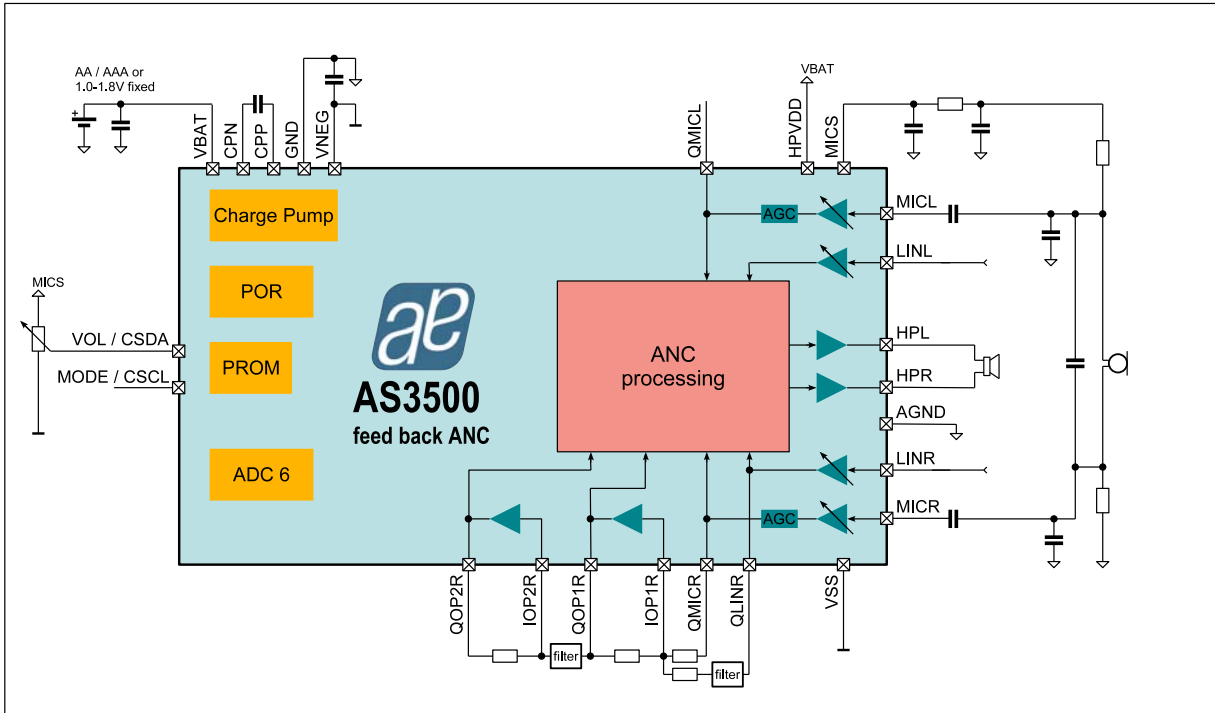

Figure 3. AS3500 Feed-Forward Block Diagram



Contents

1 General Description	1
2 Key Features	1
3 Applications	1
4 Pinout	5
4.1 Pin Assignment	5
4.2 Pin Description	6
5 Absolute Maximum Ratings	7
6 Electrical Characteristics	8
7 Typical Operating Characteristics	9
8 Detailed Description	12
8.1 Audio Line Input	12
8.2 Microphone Input	13
8.3 Headphone Output	15
8.4 Operational Amplifier	16
8.5 SYSTEM	17
8.6 VNEG Charge Pump	19
8.7 OTP Memory & Internal Registers	19
8.8 2-Wire-Serial Control Interface	22
9 Register Description	25
10 Application Information	35
11 Package Drawings and Markings	39
12 Ordering Information	43

Revision History

Table 1. Revision History

Revision	Date	Owner	Description
1.0	18.5.2009	pkm	official release
1.01	5.6.2009	pkm	updated application schematics
1.02	15.7.2009	pkm	typo correction
1.1	19.1.2009	pkm	updated pin and pinout description
1.11	03.8.2010	hgt	updated solder profile, power up sequences and block diagrams

4 Pinout

4.1 Pin Assignment

Please observe that pin assignment may change in preliminary data sheets.

Figure 4. Pin Assignments (Top View)

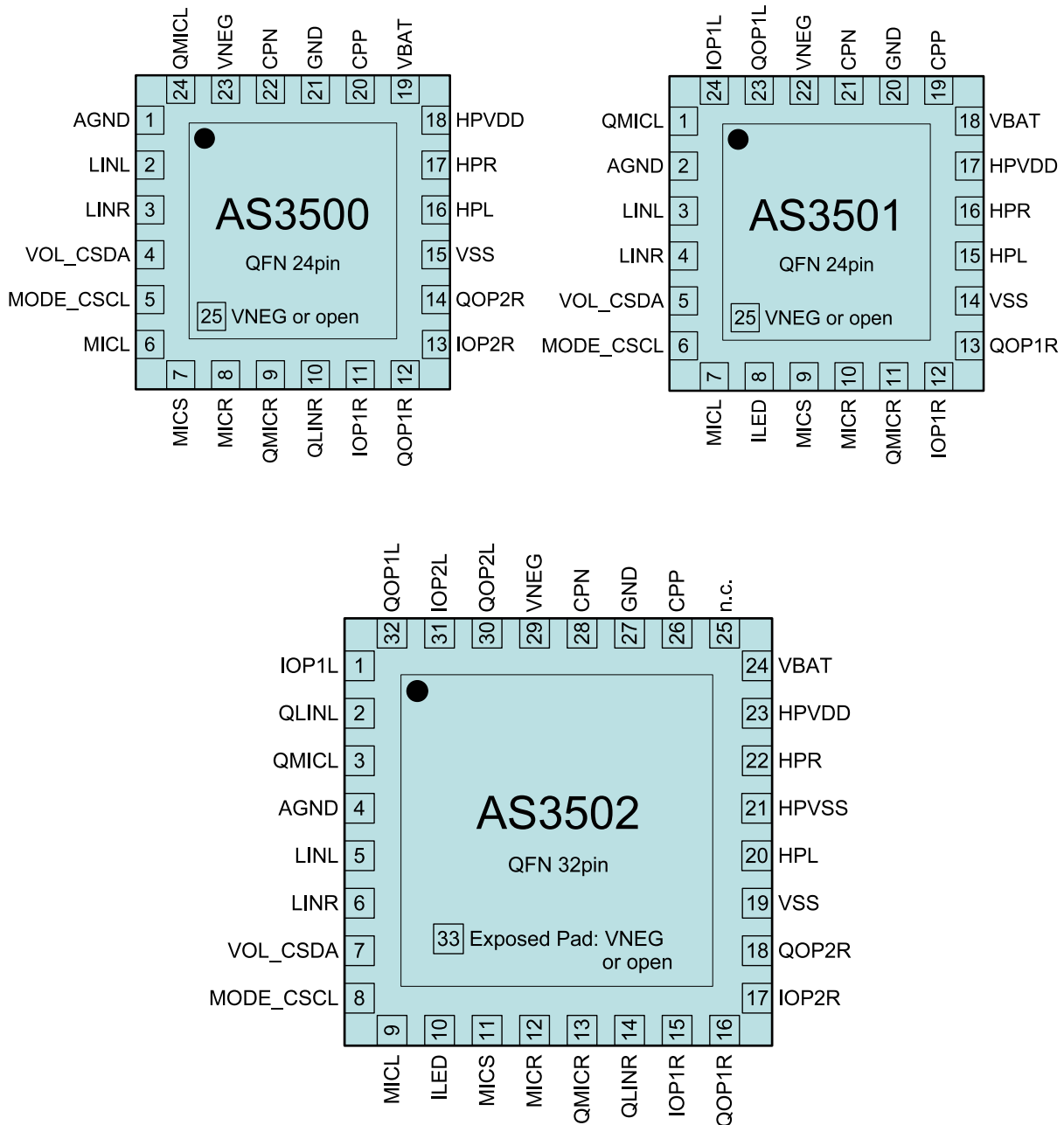

4.2 Pin Description

Please observe that pin description may change in preliminary data sheets.

Table 2. Pin Description for AS3500 AS3501 AS3502

AS3500	AS3501	AS3502	Pin Name	Type	Description
-	24	1	IOP1L	ANA IN	Filter OpAmp1 Input Left Channel
-	-	2	QLINL	ANA OUT	Line In GainStage Output Left Channel
24	1	3	QMICL	ANA OUT	MIC GainStage Output Right Channel
1	2	4	AGND	ANA IN	Analog Reference
2	3	5	LINL	ANA IN DIG IN	Line In Left Channel During Appl Trim Mode Write – CSDA During Appl Trim Mode Burn - VNEG
3	4	6	LINR	ANA IN DIG IO	LineIn Right Channel During Appl Trim Mode Write – CSCL During Appl Trim Mode Burn - Clock
4	5	7	VOL_CSDA	MIXED IO	Serial Interface Data ADC Input for volume regulation
5	6	8	MODE_CSCL	DIG IN	Mode Pin (PowerUp/Dn, Monitor) Serial Interface Clock
6	7	9	MICL	ANA IN	Microphone In Left Channel
-	8	10	ILED	ANA OUT	Current Output for on-indication LED
7	9	11	MICS	ANA OUT	Microphone Supply
8	10	12	MICR	ANA IN	Microphone Input Right Channel
9	11	13	QMICR	ANA OUT	MIC GainStage Output Right Channel
10	-	14	QLINR	ANA OUT	Line In GainStage Output Right Channel
11	12	15	IOP1R	ANA IN	FilterOpAmp1 Input Right Channel
12	13	16	QOP1R	ANA IN	Filter OpAmp1 Output Right Channel
13	-	17	IOP2R	ANA IN	Filter OpAmp2 Input Right Channel
14	-	18	QOP2R	ANA OUT	Filter OpAmp2 Output Right Channel
15	14	19	VSS	SUP IN	Core and Periphery Circuit VSS Supply
16	15	20	HPL	ANA OUT	Headphone Output Left Channel
-	-	21	HPVSS	SUP IN	Headphone VSS Supply
17	16	22	HPR	ANA OUT	Headphone Output Right Channel
18	17	23	HPVDD	SUP IN	Headphone VDD Supply
19	18	24	VBAT	SUP IN	VNEG ChargePump Positive Supply
-	-	25	n.c.	-	
20	19	26	CPP	ANA OUT	VNEG ChargePump Flying Capacitor Positive Terminal
21	20	27	GND	GND	VNEG ChargePump Negative Supply
22	21	28	CPN	ANA OUT	VNEG ChargePump Flying Capacitor Negative Terminal
23	22	29	VNEG	SUP IO	VNEG ChargePump Output
-	-	30	QOP2L	ANA OUT	Filter OpAmp2 Output Left Channel
-	-	31	IOP2L	ANA IN	Filter OpAmp2 Input Left Channel
-	23	32	QOP1L	ANA OUT	Filter OpAmp1 Output Right Channel
25	25	33			Exposed Pad: connect to VNEG or leave it unconnected

5 Absolute Maximum Ratings

Stresses beyond those listed in [Table 3](#) may cause permanent damage to the device. These are stress ratings only, and functional operation of the device at these or any other conditions beyond those indicated in [Electrical Characteristics on page 9](#) is not implied. Exposure to absolute maximum rating conditions for extended periods may affect device reliability. The device should be operated under recommended operating conditions.

Table 3. Absolute Maximum Ratings

Parameter	Min	Max	Units	Comments
Reference Ground				Defined as in GND
Supply terminals	-0.5	2.0	V	Applicable for pin VBAT, HPVDD
Ground terminals	-0.5	0.5	V	Applicable for pins AGND
Negative terminals	-2.0	0.5	V	Applicable for pins VNEG, VSS, HPVSS
Voltage difference at VSS terminals	-0.5	0.5	V	Applicable for pins VSS, HPVSS
Pins with protection to VBAT	VNEG -0.5	5.0 VBAT+0.5	V	Applicable for pins CPP, CPN
Pins with protection to HPVDD	VSS -0.5	5.0 HPVDD+0.5	V	Applicable for pins LINL/R, MICL/R, ILED, HPR, HPL, QMICL/R, QLINL/R, IOPx, QOPx
other pins	VSS -0.5	5		applicable for pins MICS, VOL_CSDA, MODE_CSCL
Input Current (latch-up immunity)	-100	100	mA	Norm: JEDEC 17
Continuous Power Dissipation (T_A = +70°C)				
Continuous Power Dissipation	-	200	mW	P _T ¹ for QFN16/24/32 package
Electrostatic Discharge				
Electrostatic Discharge HBM		+/-2	kV	Norm: JEDEC JESD22-A114C
Temperature Ranges and Storage Conditions				
Operating Temperature Range	-20	+85	°C	
Junction Temperature		+110	°C	
Storage Temperature Range	-55	+125	°C	
Humidity non-condensing	5	85	%	
Bump Temperature (soldering)				
Package Body Temperature		260	°C	Norm IPC/JEDEC J-STD-020C

1. Depending on actual PCB layout and PCB used

6 Electrical Characteristics

VBAT = 1.0V to 1.8V, T_A = -20°C to +85°C. Typical values are at VBAT = 1.5V, T_A = +25°C, unless otherwise specified.

Table 4. Electrical Characteristics

Symbol	Parameter	Condition	Min	Max	Unit
Supply Voltages					
GND	Reference Ground		0	0	V
VBAT, HPVDD	Battery Supply Voltage	normal operation MODE pin high	1.0	1.8	V
		two wire interface operation	1.4	1.8	V
VNEG	ChargePump Voltage		-1.8	-0.7	V
VSS	Analog neg. Supply Voltages HPVSS, VSS, VNEG		-1.8	-0.7	V
V _{DELTA-}	Difference of Ground Supplies GND, AGND	To achieve good performance, the negative supply terminals should be connected to low impedance ground plane.	-0.1	0.1	V
V _{DELTA--}	Difference of Negative Supplies VSS, VNEG, HPVSS	Charge pump output or external supply	-0.1	0.1	V
V _{DELTA+}	Difference of Positive Supplies	VBAT-HPVDD	-0.25	0.25	V
other pins					
V _{MICS}	Microphone Supply Voltage	MICS	0	3.6	V
V _{HPVDD}	pins with diode to HPVDD	MICL/R, ILED, HPR, HPL, QMICL/R, QLINL/R, IOPx, QOPx	VSS	3.6	V
V _{VBAT}	pins with diode to VBAT	CPP, CPN	VNEG	VBAT	V
V _{CONTROL}	Control Pins	MODE_CSCL, VOL_CSDA	VSS	3.7	V
V _{TRIM}	Line Input & Application Trim Pins	LINL, LINR	VNEG -0.5 or -1.8	HPVDD +0.5 or 1.8	V

Symbol	Parameter	Condition	Min	Typ	Max	Unit
Block Power Requirements @ 1.5V VBAT						
I _{SYS}	Reference supply current	bias generation, oscillator, ILED current sink, ADC6		0.25		mA
I _{LIN}	LineIn gain stage current	no signal, stereo		0.64		mA
I _{MIC}	Mic gain stage current	no signal, stereo		2.10		mA
I _{HP}	Headphone stage current	no signal		1.70		mA
I _{VNEG}	VNEG charge pump current	no load		0.25		mA
I _{MICS}	MICS charge pump current	no load		0.06		mA
I _{MIN}	minimal supply current	sum of all above blocks		5.00		mA
I _{OP1}	OP1 supply current	no load		0.64		mA
I _{OP2}	OP2 supply current	no load		0.64		mA
I _{ILED}	ILED current sink current	100% duty cycle		2.50		mA
I _{MICB}	Microphone bias current	200uA per microphone via charge pump		1.30		mA

7 Typical Operating Characteristics

V_{BAT} = +1.5V, T_A = +25°C, unless otherwise specified.

Figure 5. LIN to HPH: THD+N versus Output Power

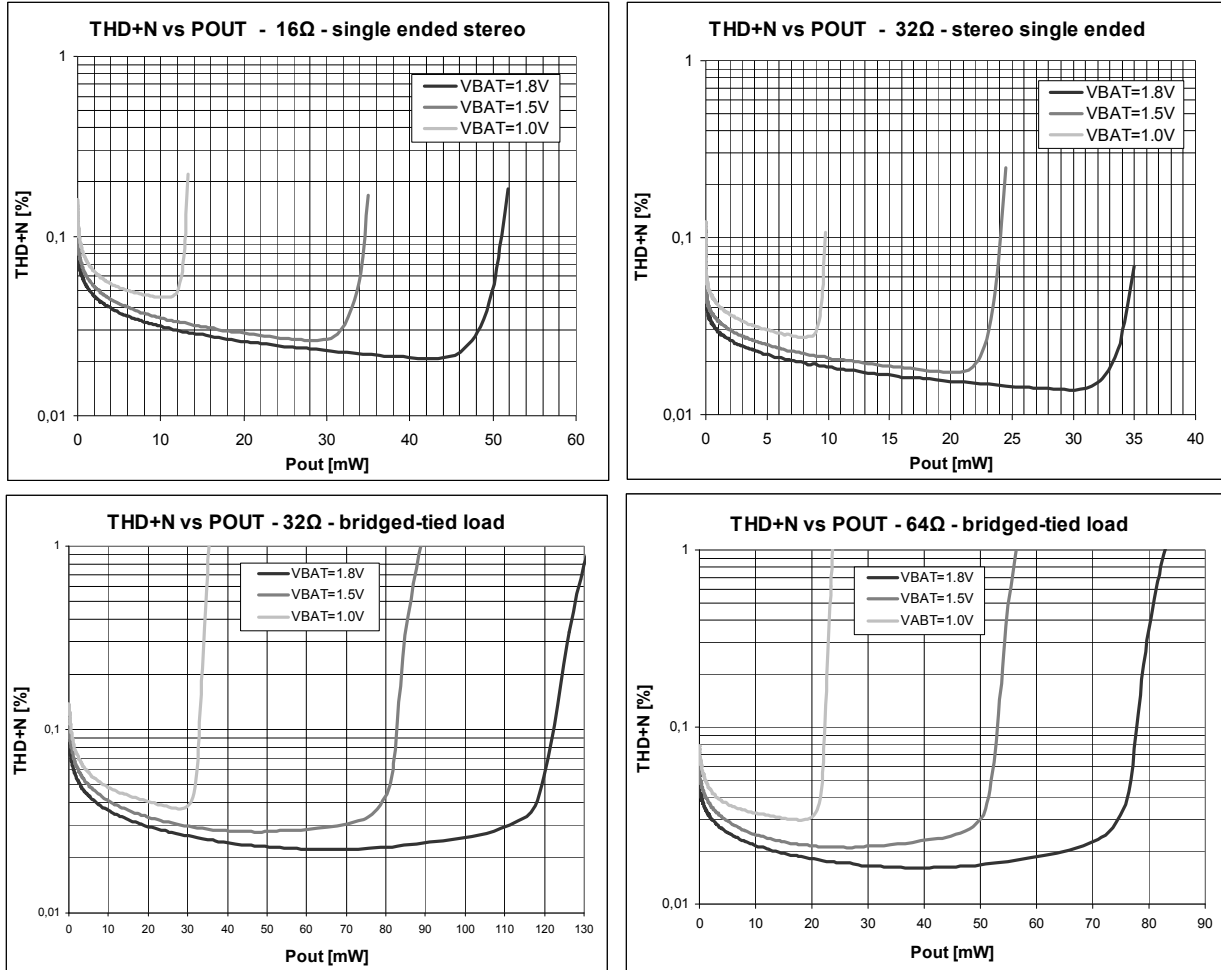

Figure 6. VNEG Charge Pump

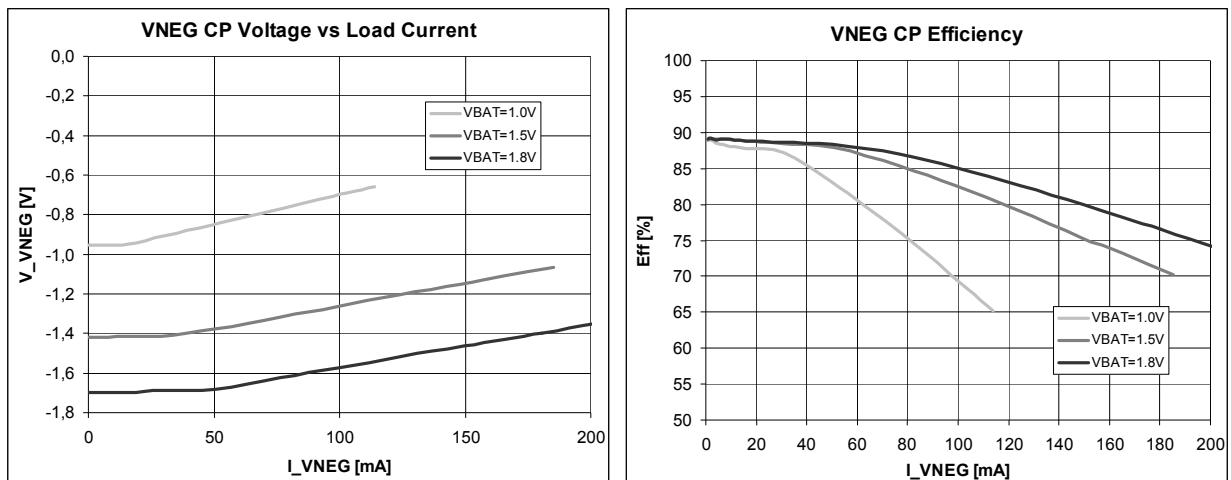

Figure 7. Microphone Supply Generation

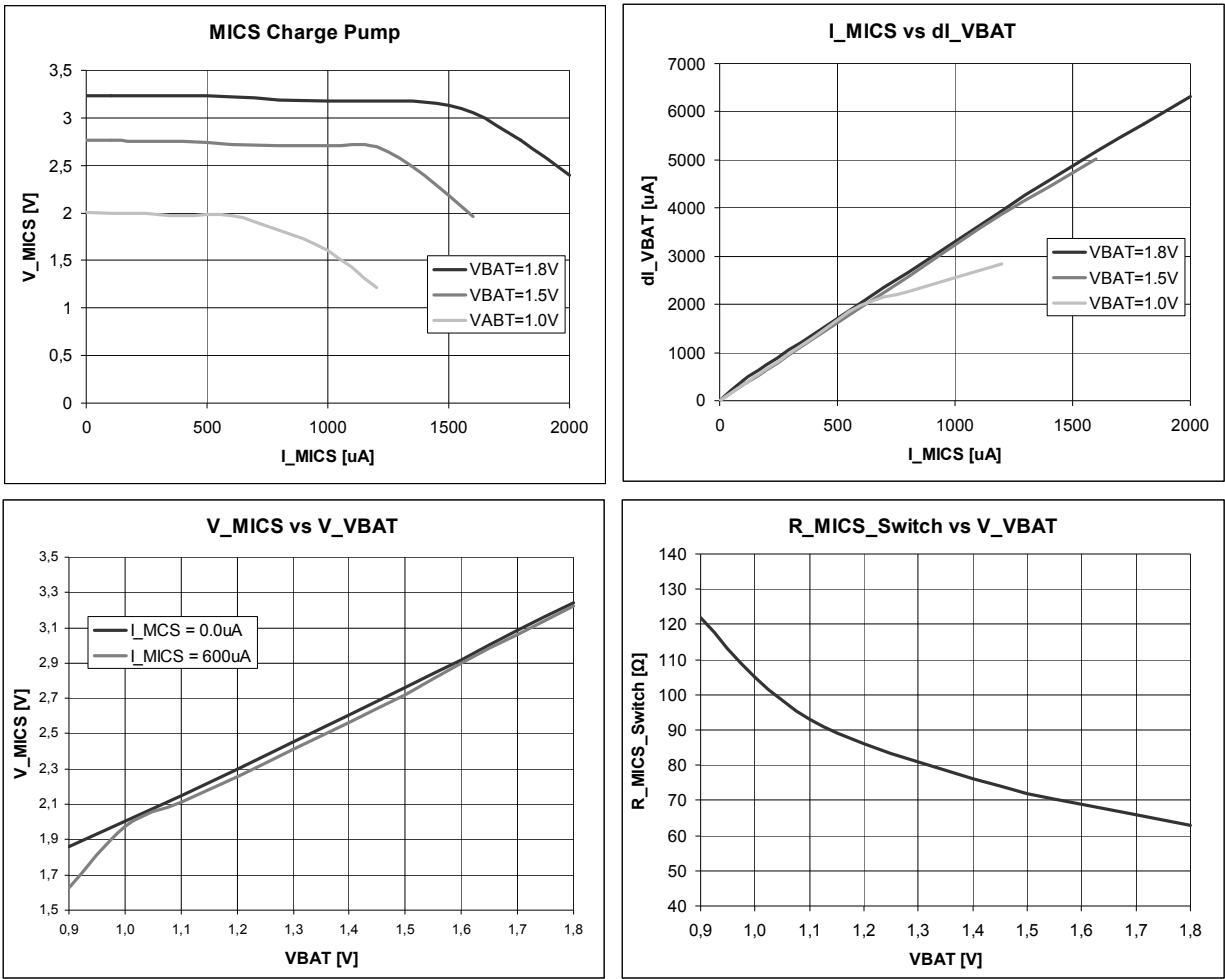

Figure 8. ILED Current Sink (100% PWM setting)

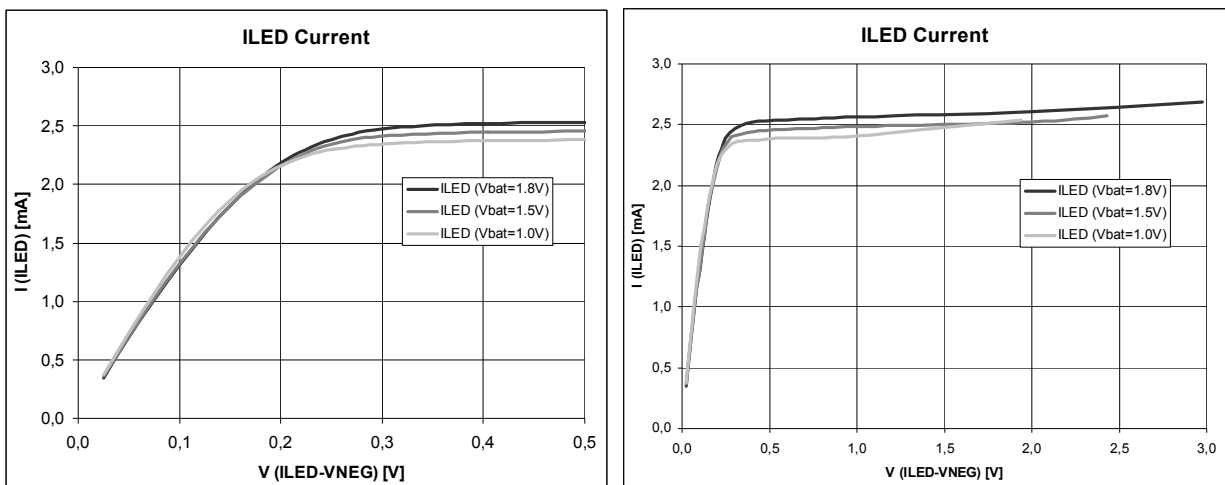

Figure 9. THD vs. frequency @ 1.5V, 16Ω, 25mW

Audio Precision

03/12/09 22:48:36

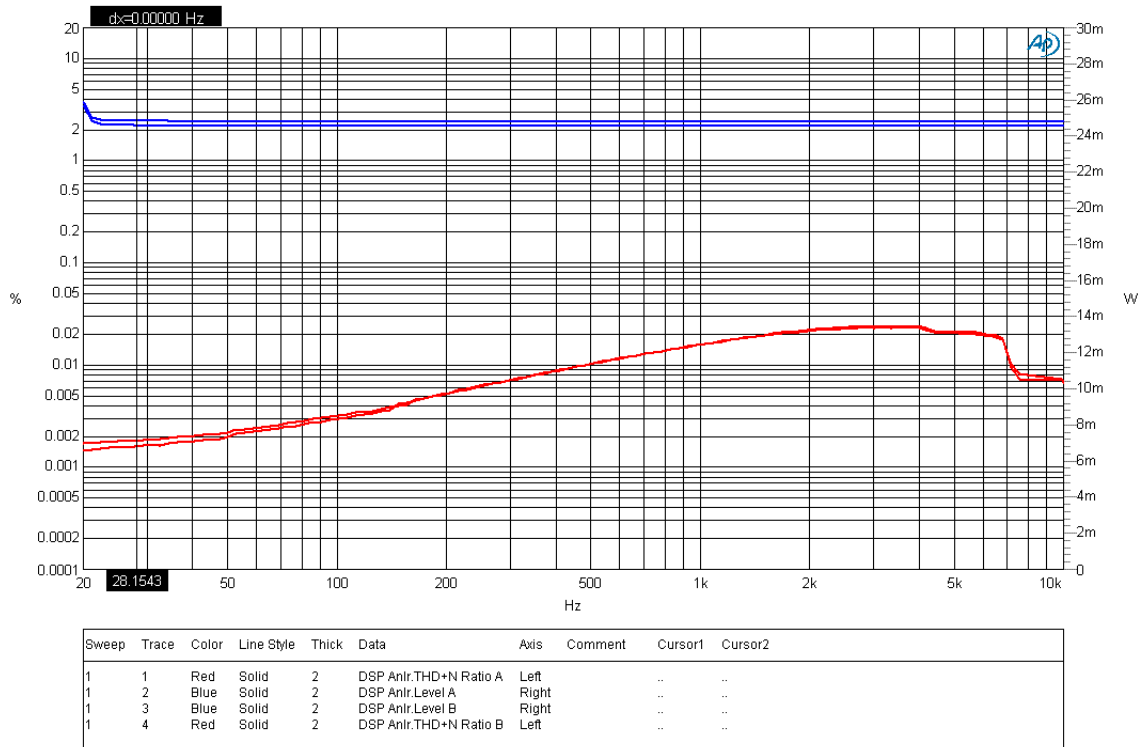
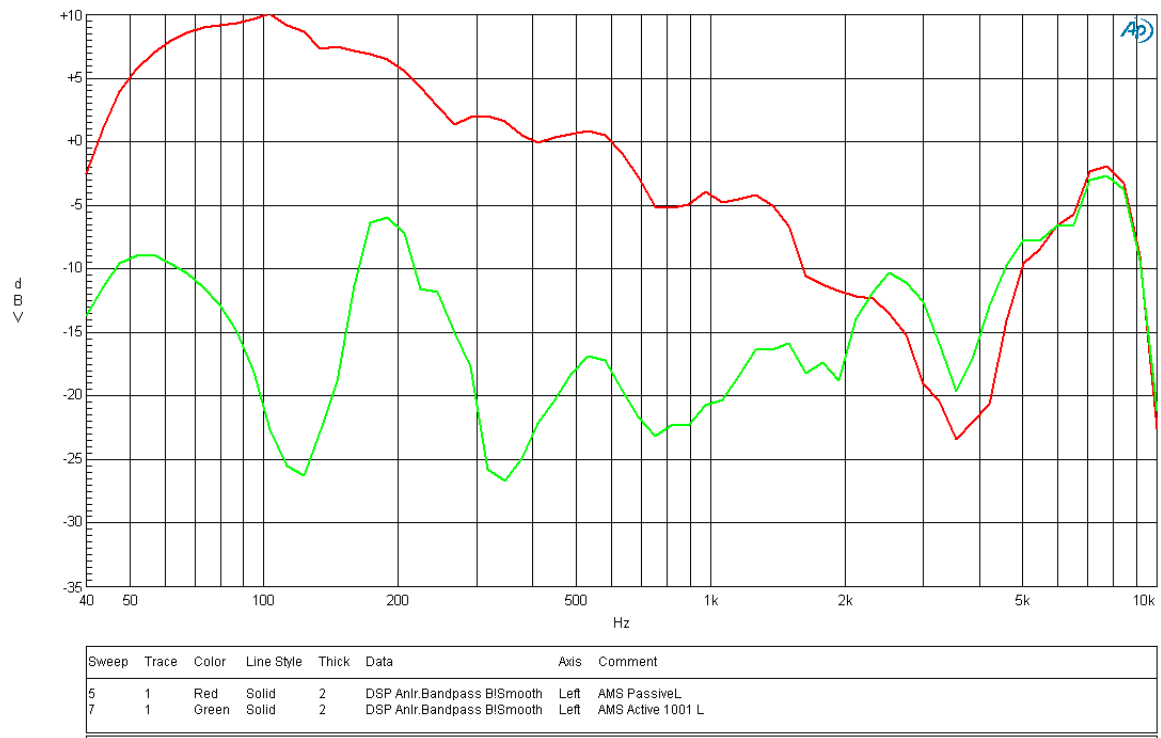

Figure 10. Typical Performance Data, FF configuration

Audio Precision

02/24/09 18:14:27



8 Detailed Description

8.1 Audio Line Input

8.1.1 General

The chip features one line input. The blocks can work in mono differential or in stereo single ended mode.

In addition to the 12.5-25k Ω input impedance, LinIn has a termination resistor of 10k Ω which is also effective during MUTE to charge eventually given input capacitors.

8.1.2 Gain Stage

The Line In gain stage is designed to have 63 gain steps of 0.75dB with a max gain of 0dB plus MUTE.

In default, the gain will be ramped up from MUTE to 0dB during startup. There is a possibility to make the playback volume user controlled by the VOL pin with an ADC converted VOL voltage or UP/DN buttons.

In monitor mode the gain stage can be set to an fixed default attenuation level for reducing the loudness of the music.

Figure 11. Line Inputs

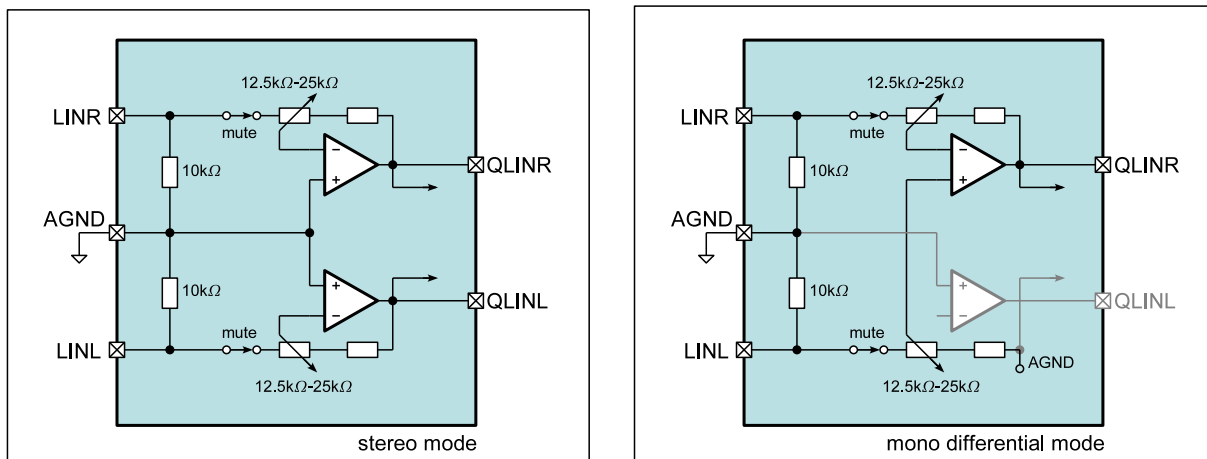

8.1.3 Parameter

V_{BAT}=1.5V, T_A= 25^oC, unless otherwise mentioned

Table 5. Line Input Parameter

Symbol	Parameter	Condition	Min	Typ	Max	Unit	
V _{LIN}	Input Signal Level			0.6* V _{BAT}	V _{BAT}	V _{PEAK}	
R _{LIN}	Input Impedance	0dB gain (12.5k // 10k)		5.6		k Ω	
		-46.5dB gain (25k // 10k)		7.2		k Ω	
		MUTE		10		k Ω	
Δ R _{LIN}	Input Impedance Tolerance			\pm 30		%	
C _{LIN}	Input Capacitance			5		pF	
A _{LIN}	Programmable Gain		-46.5		+0	dB	
		Gain Steps	discrete logarithmic gain steps		0.75		dB
		Gain Step Accuracy			0.5		dB
A _{LINMUTE}	Mute Attenuation			100		dB	

Table 5. Line Input Parameter (Continued)

Symbol	Parameter	Condition	Min	Typ	Max	Unit
Δ_{ALIN}	Gain Ramp Rate	PotiMode, Tinit=100ms		20		ms/step
		ButtonMode, Tinit=400ms		80		
		MonitorMode		8		
V_{ATTACK}	Limiter Activation Level	HPL/R start of neg. clipping				V_{PEAK}
V_{DECAY}	Limiter Release Level	HPL/R		$V_{NEG} + 0.3$		V_{PEAK}
t_{ATTACK}	Limiter Attack Time			4		μs
t_{DECAY}	Limiter Decay Time			8		ms

8.2 Microphone Input

8.2.1 General

The AFE offers two microphone inputs and one low noise microphone voltage supply (microphone bias). The inputs can be switched to single ended or differential mode.

Figure 12. Microphone Input

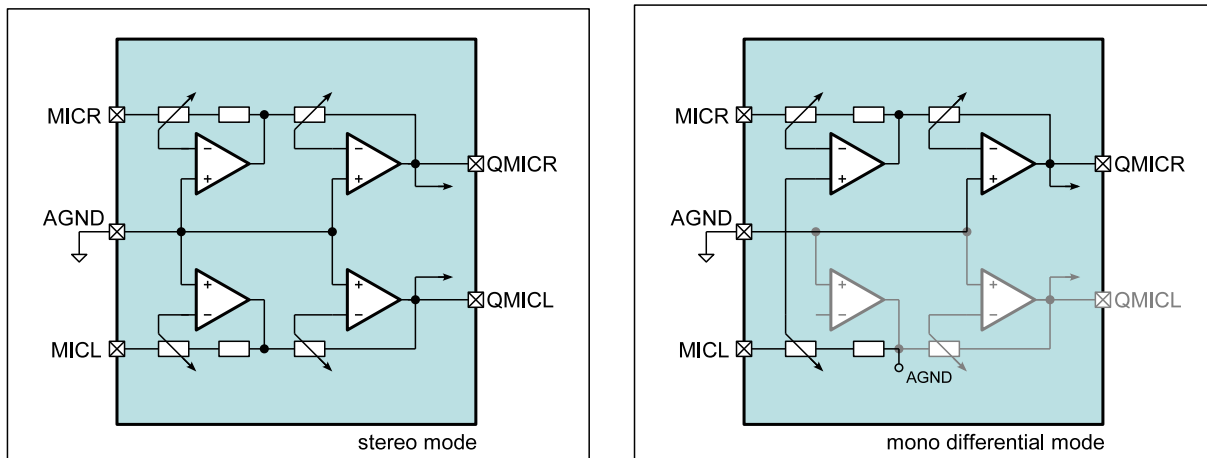

8.2.2 Gain Stage & Limiter

The Mic GainStage has programmable Gain within -6dB...+41.625dB in 128 steps of 0.375dB.

As soft-start function is implemented for an automatic gain ramping implemented with steps of 4ms to fade in the audio at the end of the start-up sequence.

A limiter automatically attenuates high input signals. The AGC has 127 steps with 0.375dB with a dynamic range of the full gain stage.

In monitor mode the gain stage can be set to an fixed (normally higher) gain level or be controlled by the VOL pin.

8.2.3 Supply

The MICS charge pump is providing a proper microphone supply voltage for the AAA supply. Since AAA batteries are operating down to 1.0V, the direct battery voltage cannot be used for mic-supply. There are 2 modes.

The first mode SWITCH-MODE for 1.8V supply is to have just a switch from VBAT to MICS. With this switch, the microphone current is switched off in idle mode.

The second mode CHAREGPUMP_MODE for AAA batteries is the real charge pump mode, in this mode a positive voltage is generated of about 2* VBAT.

It is also possible to switch off the microphone supply if not needed (e.g. playback without ANC)

8.2.4 Parameter

V_{BAT}=1.5V, T_A= 25°C unless otherwise mentioned

Table 6. Microphone Input Parameter

Symbol	Parameter	Condition	Min	Typ	Max	Unit
V _{MICIN0}	Input Signal Level	A _{MIC} = 30dB		20		mV _P
V _{MICIN1}		A _{MIC} = 36dB		10		mV _P
V _{MICIN2}		A _{MIC} = 42dB		5		mV _P
R _{MICIN}	Input Impedance	MICP to AGND		7.5		kΩ
Δ _{MICIN}	Input Impedance Tolerance			-7 +33		%
C _{MICIN}	Input Capacitance			5		pF
A _{MIC}	Programmable Gain		-6		+41.6	dB
	Gain Steps	discrete logarithmic gain steps		0.375		dB
	Gain Step Precision			0.15		dB
Δ _{AMIC}	Gain Ramp Rate	T _{init} =64ms		4		ms/ step
V _{ATTACK}	Limiter Activation Level	V _{PEAK} related to V _{BAT} or V _{NEG}		0.67		1
V _{DECAY}	Limiter Release Level			0.4		1
A _{MICLIMIT}	Limiter Gain Overdrive	127 @ 0.375dB		41.625		dB
t _{ATTACK}	Limiter Attack Time			5		μs/ step
t _{DECAY-DEB}	Limiter Decay Debouncing Time			64		ms
t _{DECAY}	Limiter Decay Time			4		ms/ step
V _{MICS}	Microphone Supply Voltage			V _{BAT} *2- 240mV		V
I _{MICSMIN}	Min. Microphone Supply Current	V _{BAT} =+1.0V V _{NEG} =-0.7V MICS=+1.75V		650		μA
R _{OUT_CP}	CP Output Resistance			1300		Ω

8.3 Headphone Output

8.3.1 General

The headphone output is a true ground output using VNEG as negative supply, designed to provide the audio signal with $2 \times 12 \text{mW}$ @ 16Ω – 64Ω , which are typical values for headphones. It is also capable to operate in bridged mode for higher impedance (e.g. 300Ω) headphone. In this mode the left output is carrying the inverted signal of the right output.

Figure 13. Headphone Output

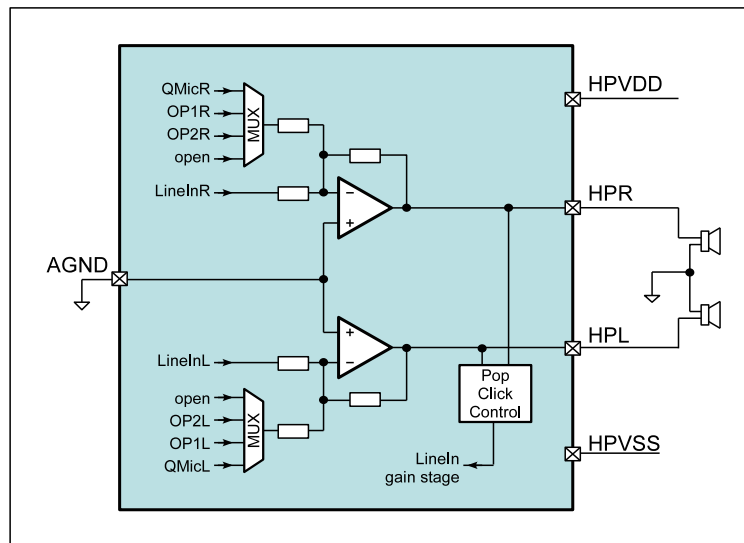

8.3.2 Input Multiplexer

The signal from the line-input gain stage gets summed at the input of the headphone stage with the microphone gain stage output, the first filter opamp output or the second filter opamp output. The microphone gain stage output is used per default. It is also possible to playback without ANC by only using the line-input gain stage with no other signal on the multiplexer.

For the monitor mode the setting of this input multiplexer can be changed to an other source, normally to the microphone.

8.3.3 No-Pop Function

The No-Pop startup of the headphone stage takes 60ms to 120ms dependent on the supply voltage.

8.3.4 No-Clip Function

The headphone output stage gets monitored by comparator stages which detect if the output signal starts to clip.

This signal is used to reduce the LineIn gain to avoid distortion of the output signal. A hysteresis avoids jumping between 2 gain steps for a signal with constant amplitude.

8.3.5 Over-current protection

The over-current protection has a threshold of 150-200mA and a debouncing time of 8 μ s. The stage is forced to OFF mode in an over-current situation. After this the headphone stage tries to power up again every 8ms as long as the over-current situation still exists or the stage is turned off manually.

8.3.6 Parameter

V_{BAT}=1.5V, T_A= 25°C, unless otherwise mentioned

Table 7. Headphone Output Parameter

Symbol	Parameter	Condition	Min	Typ	Max	Unit
R _{L_HP}	Load Impedance	stereo mode	16			Ω
C _{L_HP}	Load Capacitance	stereo mode			100	pF
P _{HP}	Nominal Output Power	R _L =16Ω-64Ω	12			mW
P _{SSRRHP}	Power Supply Rejection Ratio	200Hz-20kHz, 720mVpp, R _L =16Ω		90		dB

8.4 Operational Amplifier

8.4.1 General

While AS3501 offers only one operational amplifiers for feed-forward ANC, AS3500 and AS3502 feature an additional second operational amplifier stage to perform feed-back ANC or any other additional needed filtering.

Both operational amplifiers stages can be activated and used individually. While OP1 stage is always configured as inverting amplifier OP2 stage can be also switched to a non-inverting mode with an adjustable gain of 0..+10.5dB.

Figure 14. Operational Amplifiers

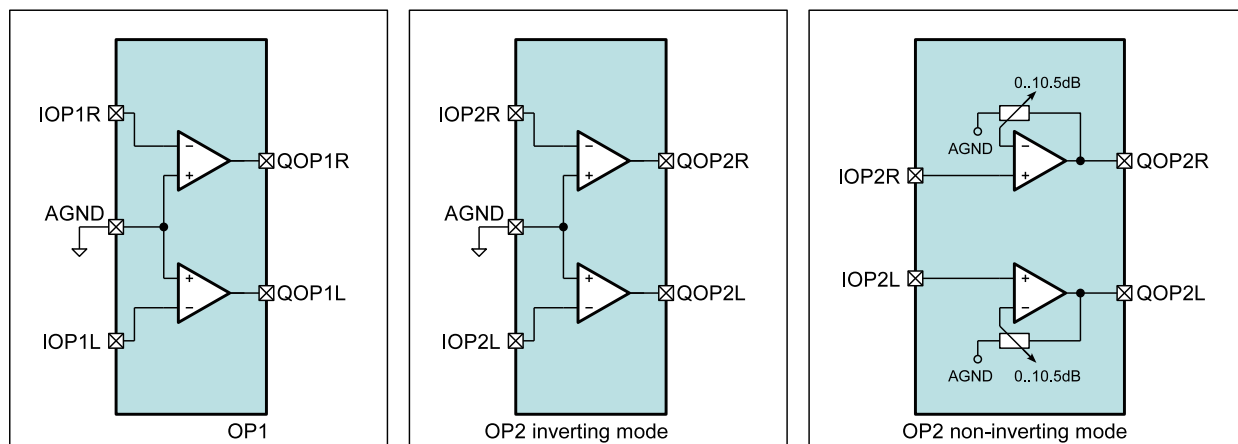

8.4.2 Parameter

V_{BAT}=1.5V, T_A= 25°C, unless otherwise mentioned

Table 8. Headphone Output Parameter

Symbol	Parameter	Condition	Min	Typ	Max	Unit
R _{L_OP}	Load Impedance	single ended	1			kΩ
C _{L_OP}	Load Capacitance	single ended			100	pF
GBW _{OP}	Gain Band Width			4.3		MHz
V _{OS_OP}	Offset Voltage				6	mV
V _{EIN_HP}	Equivalent Input Noise	200Hz-20kHz		2.6		uV

8.5 SYSTEM

8.5.1 General

The system block handles the power up and power down sequencing. As well as the mode switching.

8.5.2 Power Up/Down Conditions

The chip powers up when one of the following condition is true:

Table 9. Power UP Conditions

#	Source	Description
1	MODE pin	In stand-alone mode, MODE pin has to be driven high to turn on the device
2	I2C start	In I2C mode, a I2C start condition turns on the device

The chip automatically shuts off if one of the following conditions arises:

Table 10. Power DOWN Conditions

#	Source	Description
1	MODE pin	Power down by driving MODE pin to low
2	SERIF	Power down by SERIF writing 0h to register 20h bit <0>
3	Low Battery	Power down if VBAT is lower than the supervisor off-threshold
4	VNEG CP OVC	Power down if VNEG is higher than the VNEG off-threshold

8.5.3 Start-up Sequence

The start-up sequence depends on the used mode.

In stand-alone mode the sequence runs automatically, in I2C mode the sequence runs till a defined state and waits then for an I2C command. Either the automatic sequence is started by setting the `CONT_PWRUP` bit in addition to the `PWR_HOLD` bit. If only the `PWR_HOLD` is set all enable bits for headphone, microphone, etc have to be set manually.

Figure 15. Stand-Alone Mode Start-Up Sequence

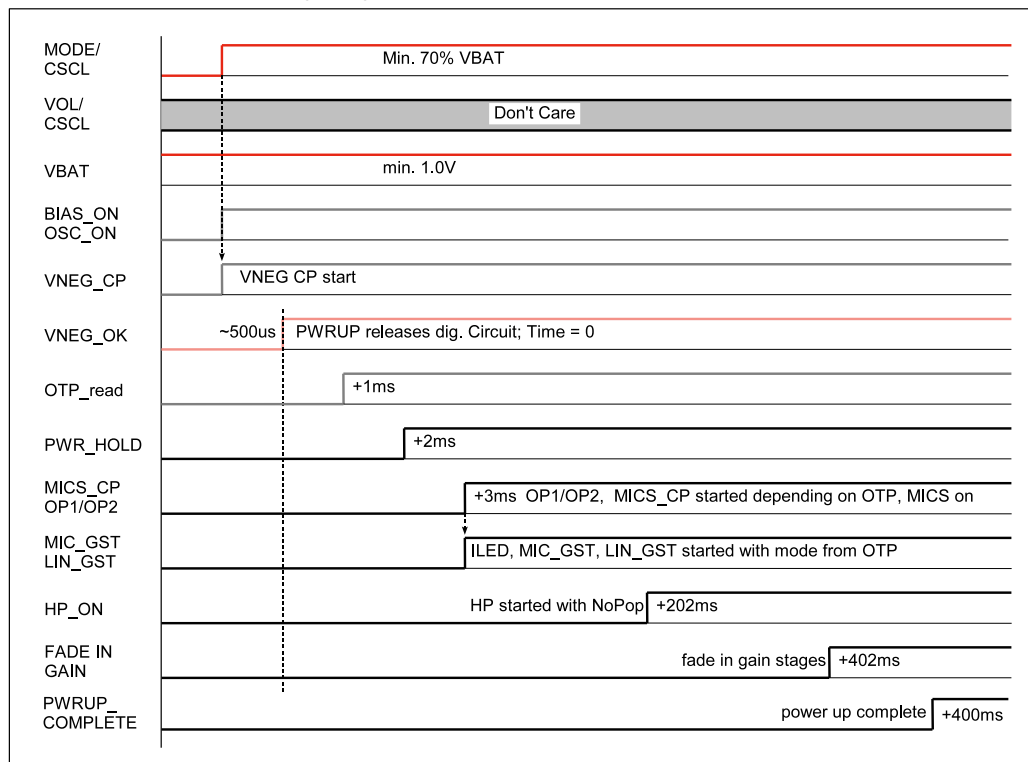
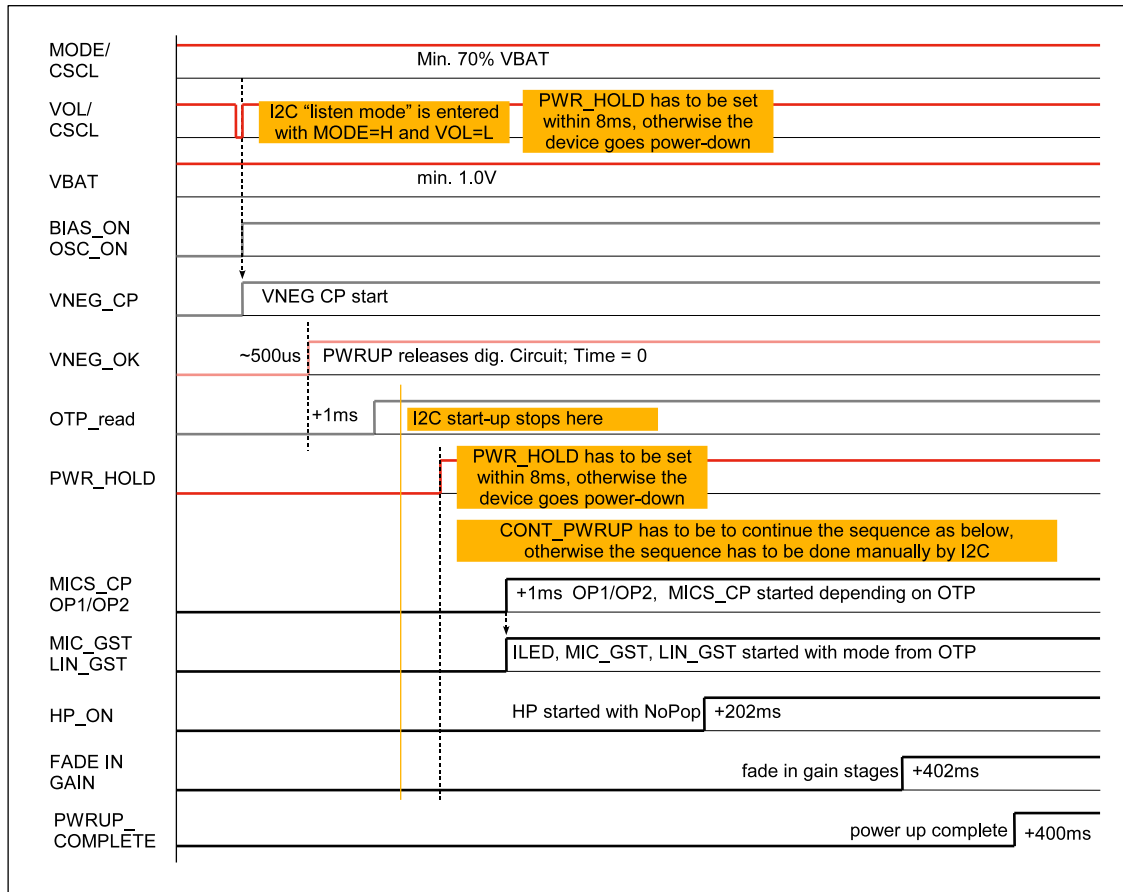

Figure 16. I2C Mode Start-Up Sequence



8.5.4 Mode Switching

When the chip in stand-alone mode (no I2C control) the mode can be switched with different levels on the MODE pin.

Table 11. Operation Modes

MODE	MODE pin	Description
OFF	LOW (VNEG)	Chip is turned off
ANC	HIGH (VBAT)	Chip is turned on and active noise cancellation is active
MONITOR	TRI-STATE (VBAT/2)	Chip is turned on and monitor mode is active In Monitor mode a different (normally higher) microphone preamplifier gain can be chosen to get an amplification of the surrounding noise. This volume can be either fixed or be controlled by the VOL input. To get rid of the low pass filtering needed for the noise cancellation, the headphone input multiplexer can be set to a different (normally to MIC) source. In addition the LineIn gain can be lowered to reduce the loudness of the music currently played back.

In I2C mode the monitor mode can be activated by setting the corresponding bit in the system register.

8.5.5 Status Indication

AS3501 and AS3502 features a on-status information via the current output pin ILED. The current can be controlled in 3 steps and be switched off, by setting the PWM accordingly (0%, 25%, 50% and 100% duty cycle of a 50kHz PWM signal).

If LOW_BAT is active, ILED switches to blinking with 1Hz, 50% duty cycle and 50% current setting.

8.6 VNEG Charge Pump

8.6.1 General

The VNEG charge pump uses one external 1uF capacitor to generate a negative supply voltage out of the battery input voltage to supply all audio related blocks. This allows a true-ground headphone output with no more need of external dc-decoupling capacitors.

8.6.2 Parameter

V_{BAT}=1.5V, T_A= 25°C, unless otherwise mentioned

Table 12. Headphone Output Parameter

Symbol	Parameter	Condition	Min	Typ	Max	Unit
V _{IN}	input voltage	V _{BAT}	1.0	1.5	1.8	V
V _{OUT}	output voltage	V _{NEG}	-0.7	-1.5	-1.8	V
C _{EXT}	external flying capacitor			1		uF

8.7 OTP Memory & Internal Registers

8.7.1 General

The OTP memory consists of OTP register and the OTP fuses. The OTP register can be written as often as wanted but will lose the content on power off. The OTP fuses are intended to store basic chip configurations as well as the microphone gain settings to optimize the ANC performance and get rid of sensitivity variations of different microphones. Burning the fuses can only be once and is a permanent change, which means the fuses keep the content even if the chip is powered down.

When the chip is controlled by a microcontroller via I2C, the OTP memory don't has to be used.

8.7.2 Register & OTP Memory configuration

The following graphics is showing the principal register interaction.

Figure 17. Register Access

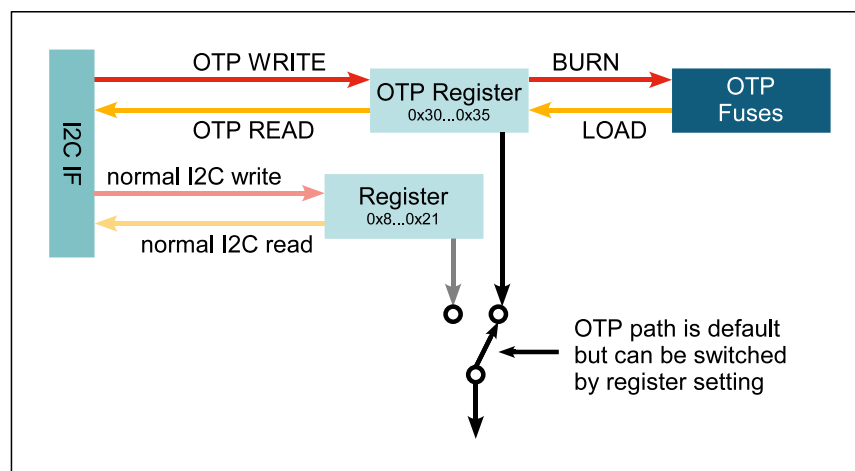

Registers 0x8, 0x9, 0xA, 0xB, 0xC and 0x21 have only effect when the corresponding “REG_ON” bit is set, otherwise the chip operates with the OTP Register settings which are loaded from the OTP fuses at every start-up.

All registers settings can be changed several times, but will lose the content on power off. When using the I2C mode the chip configuration has to be loaded from the microcontroller after every start-up. In stand alone mode the OTP fuses have to be programmed for a permanent change of the chip configuration.

A single OTP cell can be programmed only once. Per default, the cell is "0"; a programmed cell will contain a "1". While it is not possible to reset a programmed bit from "1" to "0", multiple OTP writes are possible, but only additional unprogrammed "0"-bits can be programmed to "1".

Independent of the OTP programming, it is possible to overwrite the OTP register temporarily with an OTP write command at any time. This setting will be cleared and overwritten with the hard programmed OTP settings at each power-up sequence or by a LOAD operation.

The OTP memory can be accessed in the following ways:

LOAD Operation:

The LOAD operation reads the OTP fuses and loads the contents into the OTP register. A LOAD operation is automatically executed after each power-on-reset.

WRITE Operation:

The WRITE operation allows a temporary modification of the OTP register. It does not program the OTP. This operation can be invoked multiple times and will remain set while the chip is supplied with power and while the OTP register is not modified with another WRITE or LOAD operation.

READ Operation:

The READ operation reads the contents of the OTP register, for example to verify a WRITE command or to read the OTP memory after a LOAD command.

BURN Operation:

The BURN operation programs the contents of the OTP register permanently into the OTP fuses. Don't use old or nearly empty batteries for burning the fuses.

Attention: If you once burn the OTP_LOCK bit no further programming, e.g. setting additional "0" to "1", of the OTP can be done.

For production the OTP_LOCK bit must be set to avoid an unwanted change of the OTP content during the lifetime of the product.

8.7.3 OTP fuse burning

In most stand alone applications the I2C pins are not accessible. Burning the fuses can be done by switching the line inputs into a special mode to access the chip by I2C over the line input connections. This allows trimming of the microphone gain with no openings in the final housing and so no influence to the acoustic of the headset.

This mode is called "Application Trimm" mode, or short "APT". (Patent Pending)

During the application trimm mode LINR has to provide the clock, while LINL has to provide the data for the I2C communication.

Please note that the OTP register cannot be accessed directly but have to be enabled before a read or write access. This is independent whether you access the OTP register via the normal I2C pins or in application trimm mode via LINL and LINR. Please refer to the detailed register description to get more information on how the registers can be accessed.

To achieve a proper burning of the fuses, the negative supply has to be buffered by applying an external negative supply during burning. This voltage can also be applied to the LINL terminal. An internal switch is connecting LINL and VNEG during the fuse burning. LINR has to provide the clock for burning the fuses.

The below flow chart shows the principle steps of the OTP burning process. The application trimm mode can only be entered once. There is no possibility to stop the sequence, exit and re-enter the application trimm mode to make e.g. the verification in a second step. The OTP bring sequence has to be done as shown in the flow chart.

A more detailed description of the individual steps is available in an application note.

Figure 18. OTP Burning Process

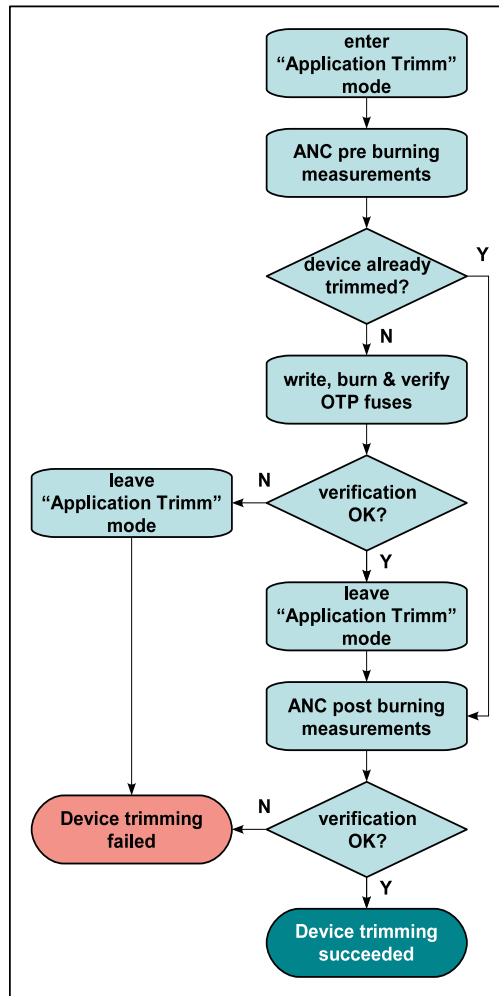

8.8 2-Wire-Serial Control Interface

8.8.1 General

There is an I2C slave block implemented to have access to 64 byte of setting information.

The I2C address is: Adr_Group8 - audio processors

- 8Eh_write
- 8Fh_read

8.8.2 Protocol

Table 13. 2-Wire Serial Symbol Definition

Symbol	Definition	RW	Note
S	Start condition after stop	R	1 bit
Sr	Repeated start	R	1 bit
DW	Device address for write	R	1000 1110b (8Eh)
DR	Device address for read	R	1000 1111b (8Fh)
WA	Word address	R	8 bit
A	Acknowledge	W	1 bit
N	No Acknowledge	R	1 bit
reg_data	Register data/write	R	8 bit
data (n)	Register data/read	W	8 bit
P	Stop condition	R	1 bit
WA++	Increment word address internally	R	during acknowledge
	AS3500 AS3501 AS3502 (=slave) receives data		
	AS3500 AS3501 AS3502 (=slave) transmits data		

Figure 19. Byte Write

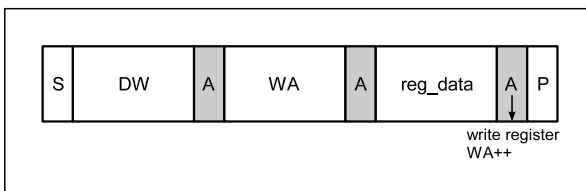
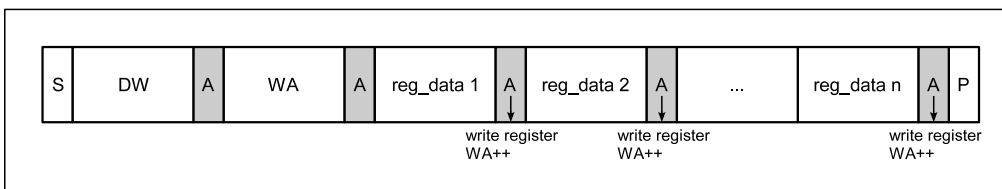

Figure 20. Page Write



Byte Write and Page Write formats are used to write data to the slave.

The transmission begins with the START condition, which is generated by the master when the bus is in IDLE state (the bus is free). The device-write address is followed by the word address. After the word address any number of data bytes can be sent to the slave. The word address is incremented internally, in order to write subsequent data bytes on subsequent address locations.

For reading data from the slave device, the master has to change the transfer direction. This can be done either with a repeated START condition followed by the device-read address, or simply with a new transmission START followed by the device-read address, when the bus is in IDLE state. The device-read address is always followed by the 1st register byte transmitted from the slave. In Read Mode any number of subsequent register bytes can be read from the slave. The word address is incremented internally.

Figure 21. Random Read

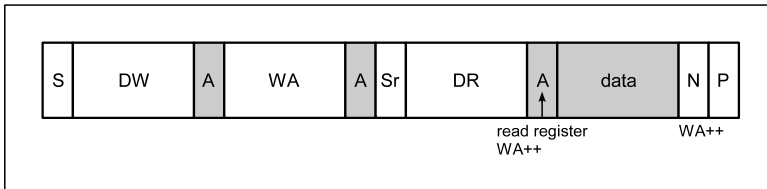

Random Read and Sequential Read are combined formats. The repeated START condition is used to change the direction after the data transfer from the master.

The word address transfer is initiated with a START condition issued by the master while the bus is idle. The START condition is followed by the device-write address and the word address.

In order to change the data direction a repeated START condition is issued on the 1st SCL pulse after the acknowledge bit of the word address transfer. After the reception of the device-read address, the slave becomes the transmitter. In this state the slave transmits register data located by the previous received word address vector. The master responds to the data byte with a not-acknowledge, and issues a STOP condition on the bus.

Figure 22. Sequential Read

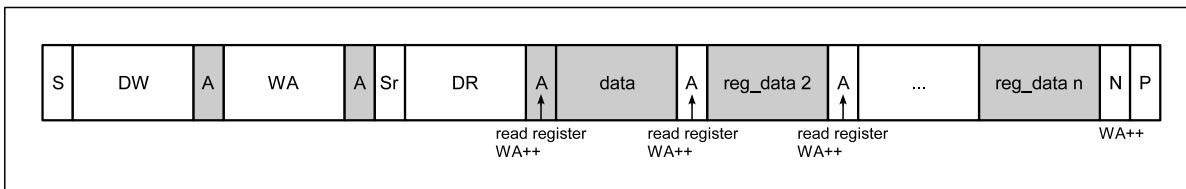

Sequential Read is the extended form of Random Read, as more than one register-data bytes are transferred subsequently. In difference to the Random Read, for a sequential read the transferred register-data bytes are responded by an acknowledge from the master. The number of data bytes transferred in one sequence is unlimited (consider the behavior of the word-address counter). To terminate the transmission the master has to send a not-acknowledge following the last data byte and generate the STOP condition subsequently.

Figure 23. Current Address Read

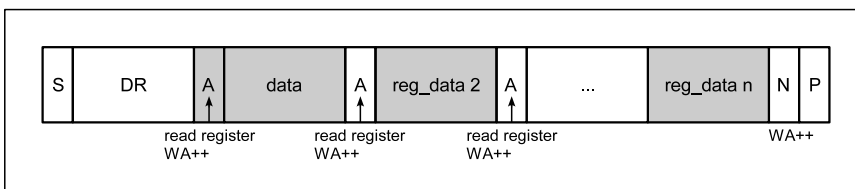

To keep the access time as small as possible, this format allows a read access without the word address transfer in advance to the data transfer. The bus is idle and the master issues a START condition followed by the Device-Read address. Analogous to Random Read, a single byte transfer is terminated with a not-acknowledge after the 1st register byte. Analogous to Sequential Read an unlimited number of data bytes can be transferred, where the data bytes has to be responded with an acknowledge from the master. For termination of the transmission the master sends a not-acknowledge following the last data byte and a subsequent STOP condition.

8.8.3 Parameter

Figure 24. 2-Wire Serial Timing

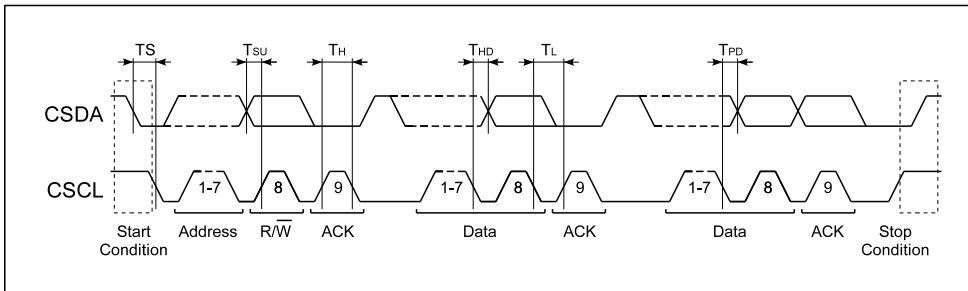

DVDD =2.9V, T_{amb}=25°C; unless otherwise specified

Table 14. 2-Wire Serial Parameter

Symbol	Parameter	Condition	Min	Typ	Max	Unit
V _{CSL}	CSCL, CSDA Low Input Level	(max 30%DVDD)	0	-	0.87	V
V _{CSH}	CSCL, CSDA High Input Level	CSCL, CSDA (min 70%DVDD)	2.03	-	5.5	V
HYST	CSCL, CSDA Input Hysteresis		200	450	800	mV
V _{OL}	CSDA Low Output Level	at 3mA	-	-	0.4	V
T _{sp}	Spike insensitivity		50	100	-	ns
T _H	Clock high time	max. 400kHz clock speed	500			ns
T _L	Clock low time	max. 400kHz clock speed	500			ns
T _{SU}		CSDA has to change Tsetup before rising edge of CSCL	250	-	-	ns
T _{HD}		No hold time needed for CSDA relative to rising edge of CSCL	0	-	-	ns
TS		CSDA H hold time relative to CSDA edge for start/stop/rep_start	200	-	-	ns
T _{PD}		CSDA prop delay relative to lowgoing edge of CSCL		50		ns