



Chipsmall Limited consists of a professional team with an average of over 10 year of expertise in the distribution of electronic components. Based in Hongkong, we have already established firm and mutual-benefit business relationships with customers from,Europe,America and south Asia,supplying obsolete and hard-to-find components to meet their specific needs.

With the principle of “Quality Parts,Customers Priority,Honest Operation,and Considerate Service”,our business mainly focus on the distribution of electronic components. Line cards we deal with include Microchip,ALPS,ROHM,Xilinx,Pulse,ON,Everlight and Freescale. Main products comprise IC,Modules,Potentiometer,IC Socket,Relay,Connector.Our parts cover such applications as commercial,industrial, and automotives areas.

We are looking forward to setting up business relationship with you and hope to provide you with the best service and solution. Let us make a better world for our industry!



Contact us

Tel: +86-755-8981 8866 Fax: +86-755-8427 6832

Email & Skype: info@chipsmall.com Web: www.chipsmall.com

Address: A1208, Overseas Decoration Building, #122 Zhenhua RD., Futian, Shenzhen, China





AS3823 LED Driver

6-channel white LED controller for LCD backlight

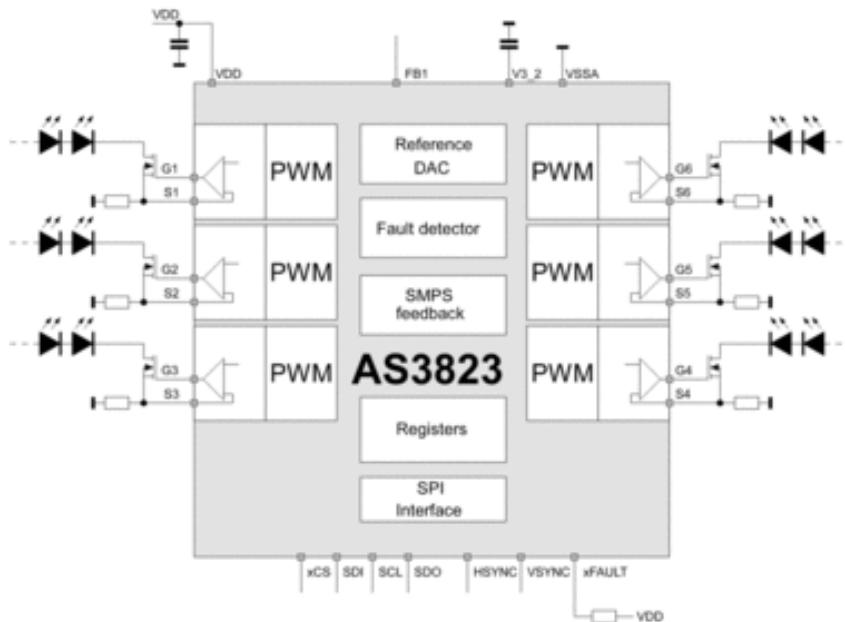

The AS3823 is a 6 channels precision LED controller for use in LCD backlight panels. Dynamic power feedback controls the external power supply to guarantee best efficiency. Build in safety features include thermal shutdown as well as open and short LED detection. The device is programmable via serial interface.

Key Features

- 6 Channel LED driver
- Output voltage only limited by external transistor
- Output current only limited by external transistor
- Linear current setting using 10-bit DAC
- Current accuracy $\pm 0.5\%$ @ VDAC=250mV

Product Facts

Compare All

| | |
|------------------------------------|---------------------------------------|
| Outputs [#] | 6 |
| LED current per output [mA] | depends on external FET |
| Features | enhanced digital feedback, 3D, DPLL |
| Error detection | √ |
| Read-back | |
| LED-to-LED matching [%] | 0.2 |
| Supply voltage [V] | 4.0 to 5.5 |
| Package | QFN32 (5x5)-0.5p TQFP32 (7x7)-0.8p |

Applications

The AS3823 is suitable for LED backlighting for LCD such as TV sets and monitors.