



Chipsmall Limited consists of a professional team with an average of over 10 year of expertise in the distribution of electronic components. Based in Hongkong, we have already established firm and mutual-benefit business relationships with customers from,Europe,America and south Asia,supplying obsolete and hard-to-find components to meet their specific needs.

With the principle of “Quality Parts,Customers Priority,Honest Operation,and Considerate Service”,our business mainly focus on the distribution of electronic components. Line cards we deal with include Microchip,ALPS,ROHM,Xilinx,Pulse,ON,Everlight and Freescale. Main products comprise IC,Modules,Potentiometer,IC Socket,Relay,Connector.Our parts cover such applications as commercial,industrial, and automotives areas.

We are looking forward to setting up business relationship with you and hope to provide you with the best service and solution. Let us make a better world for our industry!



Contact us

Tel: +86-755-8981 8866 Fax: +86-755-8427 6832

Email & Skype: info@chipsmall.com Web: www.chipsmall.com

Address: A1208, Overseas Decoration Building, #122 Zhenhua RD., Futian, Shenzhen, China





austriamicrosystems AG

is now

ams AG

The technical content of this austriamicrosystems document is still valid.

Contact information:

Headquarters:

ams AG

Tobelbaderstrasse 30

8141 Unterpremstaetten, Austria

Tel: +43 (0) 3136 500 0

e-Mail: ams_sales@ams.com

Please visit our website at www.ams.com

1 General Overview

The AS5X40 is a contactless magnetic rotary encoder for accurate angular measurement over a full turn of 360°. It is a system-on-chip, combining integrated Hall elements, analog front end and digital signal processing in a single device.

To measure the angle, only a simple two-pole magnet, rotating over the center of the chip, is required. The magnet may be placed above or below the IC.

The absolute angle measurement provides instant indication of the magnet's angular position with a resolution of $0.35^\circ = 1024$ positions per revolution (AS5X40). This digital data is available as a serial bit stream and as a PWM signal.

Furthermore, a user-programmable incremental output is available, making the chip suitable for replacement of various optical encoders.

An internal voltage regulator allows the AS5X40 to operate at either 3.3 V or 5 V supplies.

2 The AS5X40 Demoboard

The AS5X40 demoboard is a complete rotary encoder system with built-in microcontroller, USB interface, graphical LCD display, incremental indicators, commutation indicators and PWM output LED.

The board is USB powered or externally supplied with a 9V battery for standalone operation.

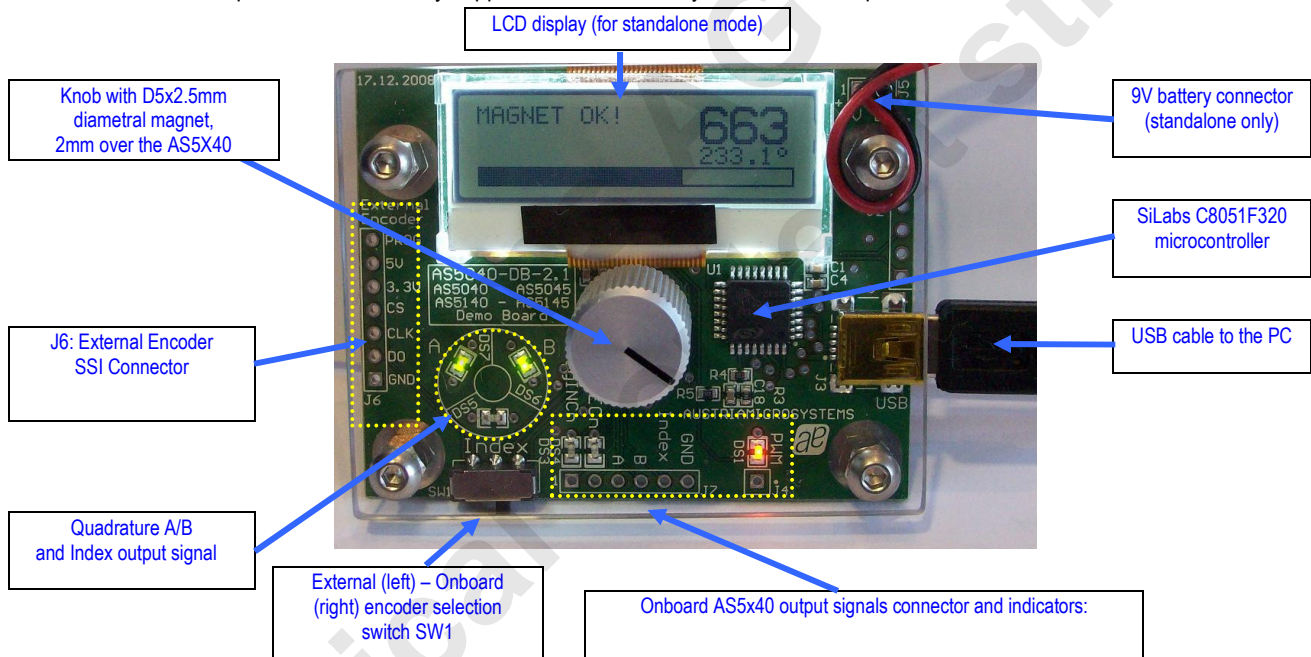

Figure 1: AS5X40 Demoboard hardware with mounted magnet knob

3 Operating the AS5X40 Demoboard

The AS5X40 demoboard can be used in several ways:

- **As standalone unit supplied by a 9V battery**

Connect a 9V battery to the battery connector on the top right side of the board. No other connections are required.

- **As standalone unit supplied by an USB port**

Connect the demoboard to a PC using a USB/USB cable (included in demoboard shipment). The board is supplied by the 5V supply of the USB port. No other connections are required.

- **As input device for the AS5000 Programmer GUI software**

This configuration uses the same USB hardware connection as above, but additionally the AS5000 Programmer GUI software is running. The LCD display will be turned off and the Angle/Multiturn/AGC will be displayed on the PC screen. Some extra features as pole pair, zero position or AGC programming can be achieved. The parameters will not be permanently programmed. All the parameters will be lost when the demoboard is shut down. For a permanent device programming, the "AS5000 Programmer" hardware should be used.

3.1 Hardware Indicators and Connectors

3.1.1 Graphic LCD display

The LCD display shows the realtime absolute angle position of the magnet with a resolution of $0.35^\circ = 1024$ positions per revolution (AS5X40) and the absolute value of the angle.

Turning the knob clockwise will increase the angle value until 359,6 then 0.

The magnet status indicator is related to the magnet position. If the magnet is too close to the encoder, "Magnet too close" will be displayed. If the magnet is too far away from the encoder, "Magnet out of range" will be displayed.

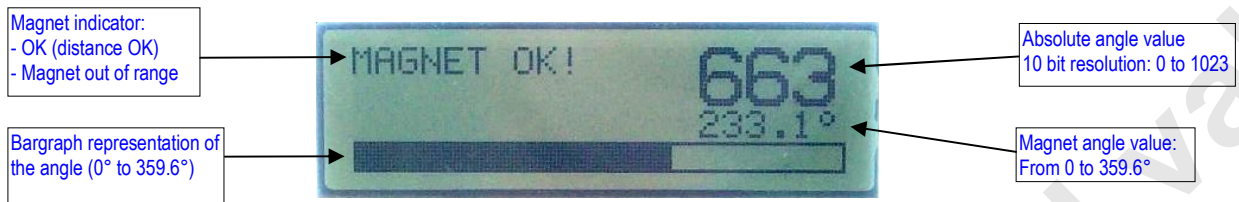

Figure 2: LCD display in standalone mode (9V battery or USB powered without GUI)

3.1.2 PWM LED

This LED is connected to the PWM output of the AS5X40. The PWM output is a pulse width that is proportional to the angle of the magnet.

The pulse width varies from $1\mu\text{s}$ to $1024\mu\text{s}$ with a repetition rate of 1.0 kHz. Viewing the PWM signal on the LED results in brightness, that is proportional to the angle of the magnet. When the angle of the magnet is at 0° , the LED is almost dark, as it is $1\mu\text{s}$ on and $1023\mu\text{s}$ off. Turning the knob clockwise towards higher angles increases the brightness of the PWM LED, since the ON-pulse becomes longer and the OFF-pulse becomes shorter.

Likewise, the PWM output can be used as an analog output proportional to the angle, when the PWM signal is filtered by a RC (or active) lowpass filter.

The PWM signal (0 ~ 3V3) can be directly taken from the connector J4.

3.1.3 Incremental quadrature AB-Index LED

The phase shift between channel A and B indicates the direction of the magnet movement. Channel A leads channel B at a clockwise rotation of the magnet (top view) by 90 electrical degrees. Channel B leads channel A at a counter clockwise rotation.

One Index pulse (3V3) is generated at the angle 0 (see AS5X40 datasheet Figure 9)

The AB-Index LEDs are directly connected to the A B Index outputs of the AS5X40. These quadrature signals (0 – 3V3) are available on connector J7.

3.1.4 MagINCn and MagDECn

MagINCn and MagDECn are the magnetic field change indicators (magnetic field strength increase or decrease through variation of the distance between the magnet and the device).

These outputs can be used to detect the valid magnetic field range. If both indicators lit simultaneously (MagINCn = 0 and MagDECn = 0), the magnet is out of range, the airgap between the encoder and the magnet is too high or too low. In that case, "Magnet out of range" will be displayed on the LCD display.

3.1.5 Encoder selection switch

The switch SW1 selects the encoder which communicates with the microcontroller through the SSI bus:

1. Right position (default): Onboard AS5040/AS5140
2. Left Position: External AS5040/AS5140 connected on J6
The signals of the synchronous serial interface (DO, CLK, CSn, PROG) and the power supply (3.3V, GND) of an external device can be connected directly to J6. In this configuration, the data of the serial interface are displayed on the GUI or the LCD.

- In standalone mode, regardless to the demoboard type (AS5040 or AS5140), AS5040 and AS5140 can be attached to J6 and evaluated. See figure 3.
- If the GUI is used for operation, additional devices AS5043, AS5143, AS5045 and AS5145 can be connected to J6 and evaluated. In that case, the correct encoder must be selected instead of "Autoselect" in the Device list of the PC software, see chapter **Error! Reference source not found.** figure 4.

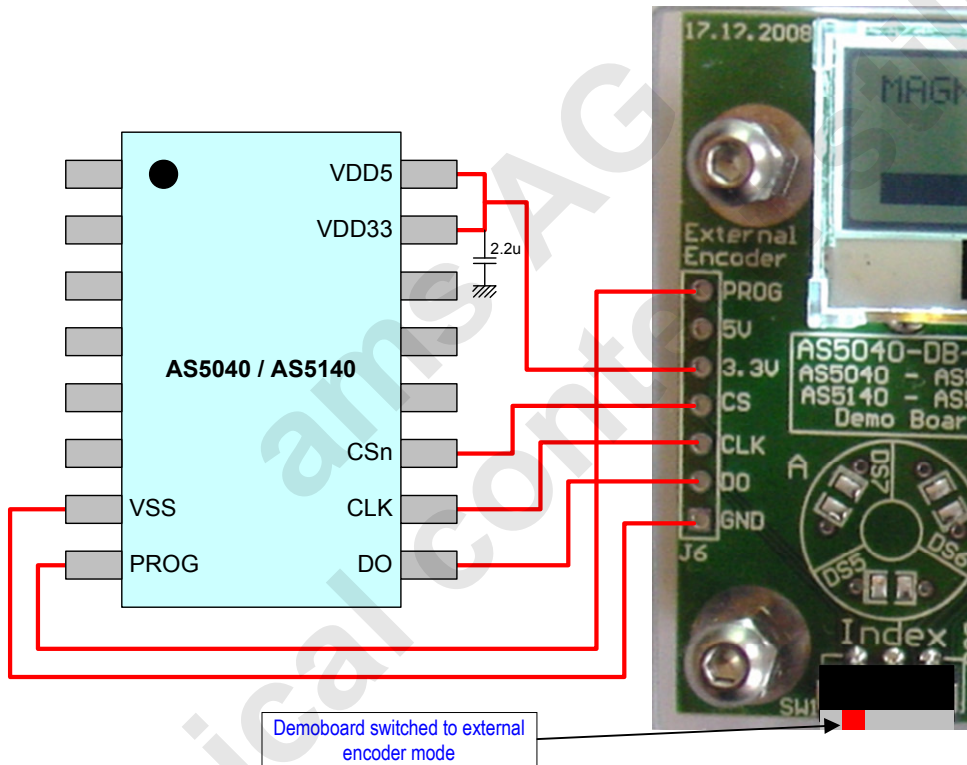

Figure 3: external AS5040/AS5140 connection to the demoboard

4 AS5000 Programmer GUI software

4.1 Installing the GUI on the PC

The preliminary software is developed for a Microsoft Windows XP operating system with Service Pack 2. In addition the dotnet (.NET) framework version 2.0 or more must be installed on the PC. This package can be downloaded free of charge from the Microsoft webpage:

<http://www.microsoft.com/downloads/details.aspx?FamilyID=0856eacb-4362-4b0d-8edd-aab15c5e04f5&displaylang=en>

Following Procedure is recommended before starting the GUI:

1. check on your PC if Service Pack 2 is installed
2. install the mentioned .NET package to your computer
3. execute setup.exe
4. Finally start the GUI using the shortcut in the start menu or desktop.

4.2 The Home tab

Figure 4 shows the main window of the GUI. On the top left corner, board information's as firmware (FW) version and demoboard name declaration can be found.

By default the GUI is in the auto detection mode. Any connected austriamicrosystems demoboard and programming tool will be automatically detected and displayed in the right top corner. The GUI is divided into three main sections HOME, SSI and OTP.

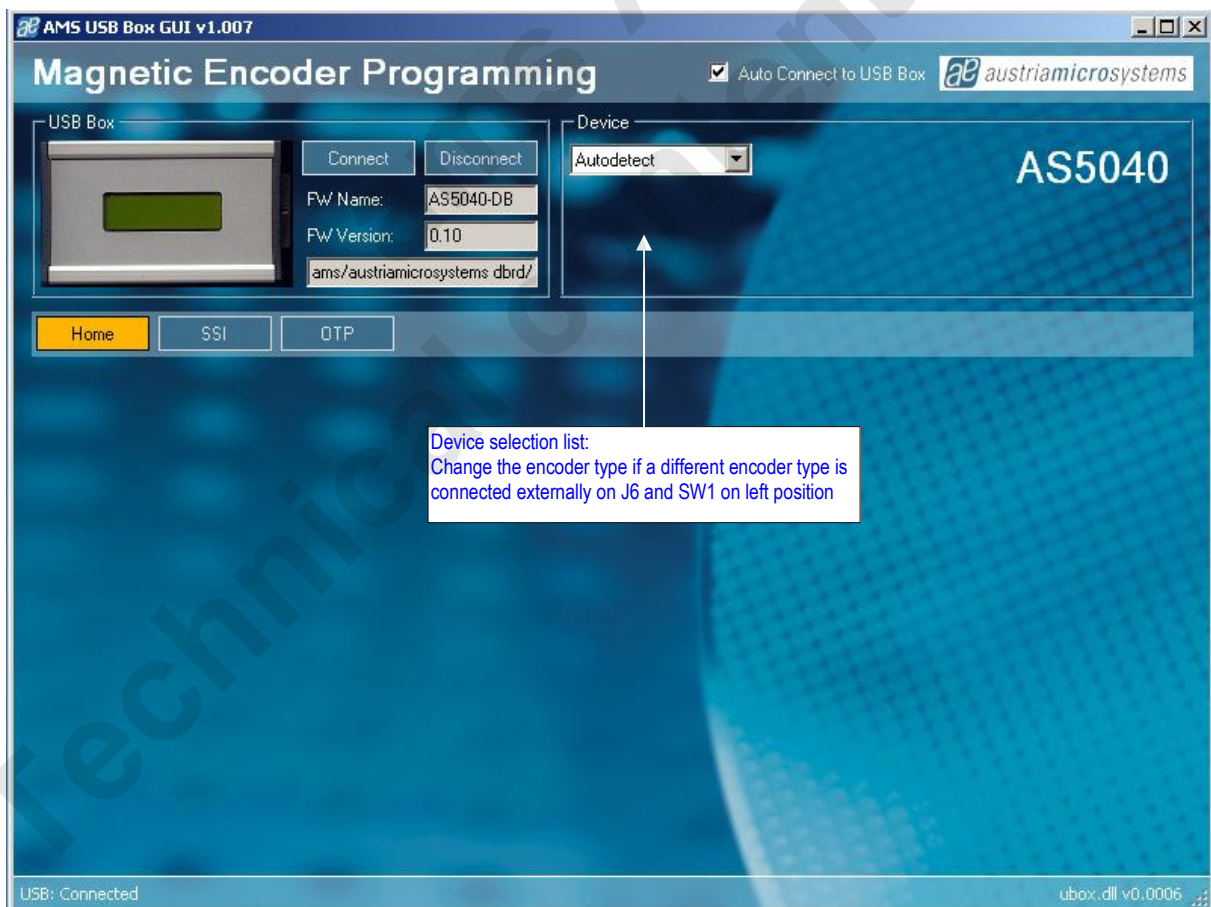

Figure 4: AS5000 GUI detected the AS5040 Demoboard

4.3 The SSI tab

This mode displays in realtime the angle & absolute value, status bits and magnet range status.

By selecting the SSI (serial protocol for AS5040, AS5140, AS5043, AS5143, AS5045, AS5145) tab, the information of the angular position and the status bits appears. See figure 5.



Figure 5: SSI tab, allows access to the AS5X40 registers from the serial bus

Value is the Angle data [D9:D0] from the RD_ANGLE (Read Angle) serial command. This value is continuously updated.

The **Zero Pos.** value represents the Zero Position register. By clicking on the **Set** button, the actual angle "Value" is written into the Zero Position register. Clicking on **Reset** writes the value 0 to the Zero Position register.

The **Magnetic Range Warning** is continuously read from the RD_ANGLE serial command.

- Green lamp: Magnet in range
- Orange lamp: Magnet too far or too close. MagINC and MagDEC are set.

The **Status bits information** are taken from the serial stream.

The **Read Interval** can be modified from 10 ms (fastest) to 1 s (slowest).

4.4 The OTP tab

The OTP tab is normally used for the AS5000 programmer, but the OTP bits can be changed on the AS5X40 demoboard as well.

Options like Zero Position, Pulses per revolution and Incremental Mode Selection can be changed by selecting the function in "Fields", then changing the parameter in "Options for the selected field" or directly the decimal value of this parameter in "Value".

Each time a field's value has been changed, the corresponding OTP bits will be automatically checked in the right window. The button **Write** should be clicked to write the parameter into the AS5X40.

The **Read** button reads back the OTP register, and updates the "Field" parameter as well as the OTP bits window.

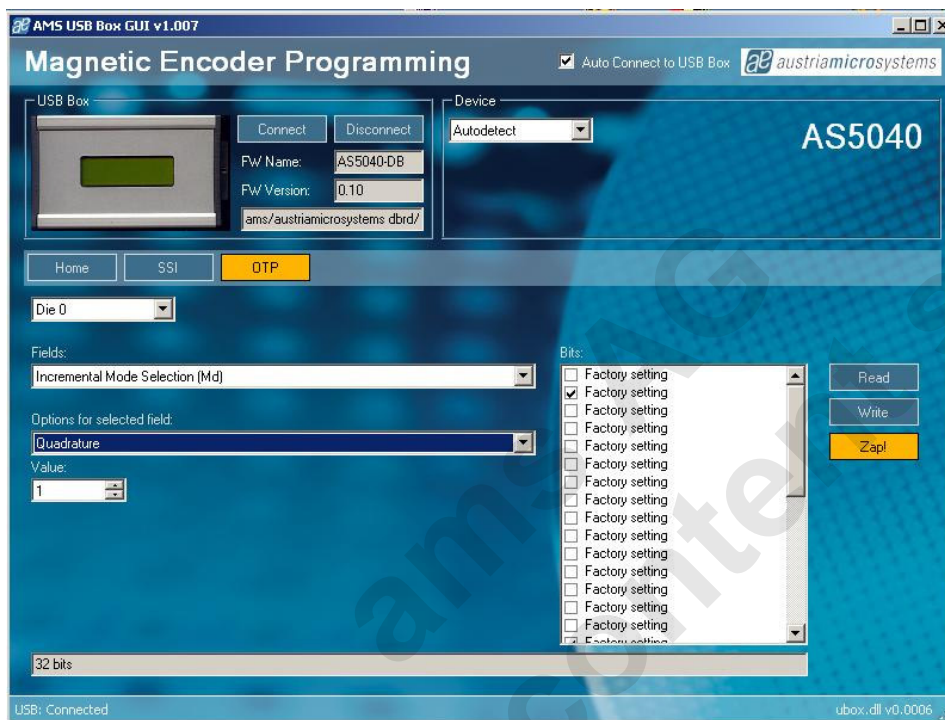

Figure 6: OTP tab

Field Zero Position: To zero position value, like on the SSI tab. The zero position value can be changed by checking the Z[0:9] bits, or changing the Value field with a decimal number.

Field Pulses per Revolution: (The resolution can be reduced from 10bit down to 9, 8, 7 bit, by using the divider setting bits Div1 and Div0)

- 0: 256 ppr (10 bit)
- 1: 128 ppr (9 bit)
- 2: 64 ppr (8 bit)
- 3: 32 ppr (7 bit)

Field Incremental Mode Selection: To change the Incremental AB-Index output to:

- 0: Default
- 1: Quadrature
- 2: Step Dir
- 3: Commutation

Note that the **Zapl** button is used for the AS5000 Programmer only and has no effect on the AS5X40 Demoboard.

5 AS5X40 Demoboard, Schematics, Blockdiagramm

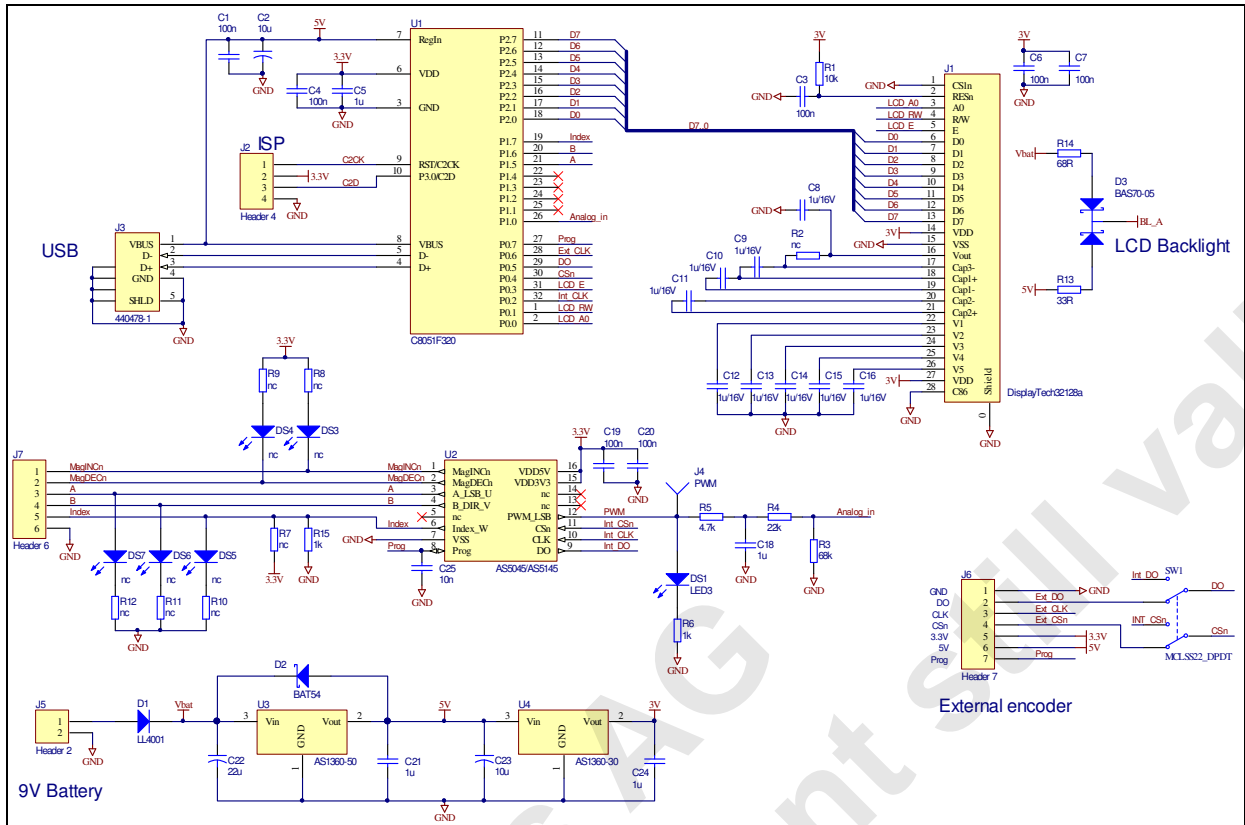

Figure 7: AS5x40 Demoboard schematics

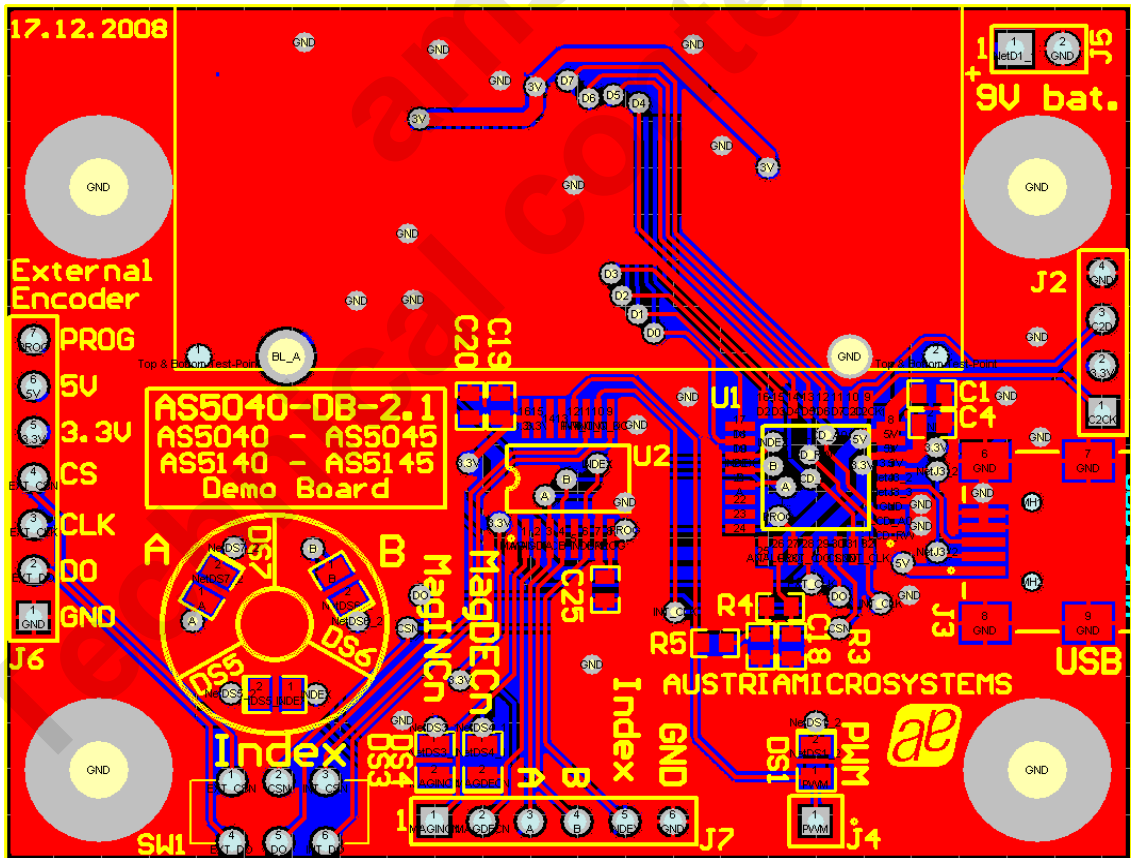

Figure 4: AS5x40 Demoboard PCB Layout

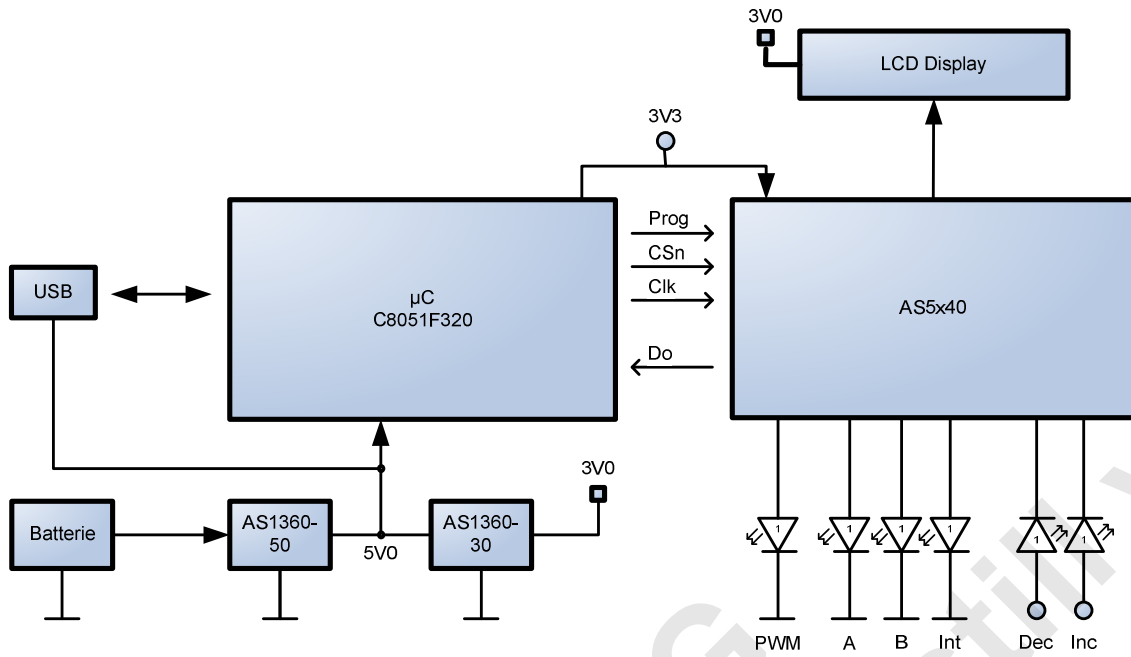

Figure 9: AS5x40 Blockdiagramm

Index

| | | |
|-------|---|----|
| 1 | General Overview | 1 |
| 2 | The AS5X40 Demoboard | 1 |
| 3 | Operating the AS5X40 Demoboard..... | 1 |
| 3.1 | Hardware Indicators and Connectors | 2 |
| 3.1.1 | Graphic LCD display | 2 |
| 3.1.2 | PWM LED | 2 |
| 3.1.3 | Incremental quadrature AB-Index LED | 2 |
| 3.1.4 | MagINCn and MagDECn | 2 |
| 3.1.5 | Encoder selection switch..... | 3 |
| 4 | AS5000 Programmer GUI software..... | 4 |
| 4.1 | Installing the GUI on the PC | 4 |
| 4.2 | The Home tab | 4 |
| 4.3 | The SSI tab..... | 5 |
| 4.4 | The OTP tab | 6 |
| 5 | AS5X40 Demoboard, Schematics, Blockdiagramm | 7 |
| | Index..... | 9 |
| | Revision History | 10 |
| | Contact..... | 11 |
| | Copyright..... | 12 |

Revision History

| Revision | Date | Description | |
|----------|----------------|---------------|--|
| R1.0 | March.16, 2009 | First version | |
| | | | |
| | | | |
| | | | |
| | | | |
| | | | |
| | | | |

Contact

Headquarters

austriamicrosystems AG
 A 8141 Schloss Premstätten, **Austria**
 Phone: +43 3136 500 0
 Fax: +43 3136 525 01
industry.medical@austriamicrosystems.com
www.austriamicrosystems.com

Sales Offices

austriamicrosystems Germany GmbH
 Tegernseer Landstrasse 85
 D-81539 München, **Germany**
 Phone: +49 89 69 36 43 0
 Fax: +49 89 69 36 43 66

austriamicrosystems Italy S.r.l.
 Via A. Volta, 18
 I-20094 Corsico (MI), **Italy**
 Phone: +39 02 4586 4364
 Fax: +39 02 4585 773

austriamicrosystems France S.A.R.L.
 124, Avenue de Paris
 F-94300 Vincennes, **France**
 Phone: +33 1 43 74 00 90
 Fax: +33 1 43 74 20 98

austriamicrosystems Switzerland AG
 Rietstrasse 4
 CH 8640 Rapperswil, **Switzerland**
 Phone: +41 55 220 9008
 Fax: +41 55 220 9001

austriamicrosystems UK, Ltd.
 88, Barkham Ride,
 Finchampstead, Wokingham
 Berkshire RG40 4ET, **United Kingdom**
 Phone: +44 118 973 1797
 Fax: +44 118 973 5117

austriamicrosystems AG
 Klaavuntie 9 G 55
 FI 00910 Helsinki, **Finland**
 Phone: +358 9 72688 170
 Fax: +358 9 72688 171

austriamicrosystems AG
 Bivägen 3B
 S 19163 Sollentuna, **Sweden**
 Phone: +46 8 6231 710

austriamicrosystems USA, Inc.
 8601 Six Forks Road
 Suite 400
 Raleigh, NC 27615, **USA**
 Phone: +1 919 676 5292
 Fax: +1 509 696 2713

austriamicrosystems USA, Inc.
 4030 Moorpark Ave
 Suite 116
 San Jose, CA 95117, **USA**
 Phone: +1 408 345 1790
 Fax: +1 509 696 2713

austriamicrosystems AG
 Suite 811, Tsimshatsui Centre
 East Wing, 66 Mody Road
 Tsim Sha Tsui East, Kowloon, **Hong Kong**
 Phone: +852 2268 6899
 Fax: +852 2268 6799

austriamicrosystems AG
 AIOS Gotanda Annex 5th Fl., 1-7-11,
 Higashi-Gotanda, Shinagawa-ku
 Tokyo 141-0022, **Japan**
 Phone: +81 3 5792 4975
 Fax: +81 3 5792 4976

austriamicrosystems AG
 #805, Dong Kyung Bldg.,
 824-19, Yeok Sam Dong,
 Kang Nam Gu, Seoul
Korea 135-080
 Phone: +82 2 557 8776
 Fax: +82 2 569 9823

austriamicrosystems AG
 Singapore Representative Office
 83 Clemenceau Avenue, #02-01 UE Square
 239920, **Singapore**
 Phone: +65 68 30 83 05
 Fax: +65 62 34 31 20

Copyright

Devices sold by austriamicrosystems are covered by the warranty and patent indemnification provisions appearing in its Term of Sale. austriamicrosystems makes no warranty, express, statutory, implied, or by description regarding the information set forth herein or regarding the freedom of the described devices from patent infringement. austriamicrosystems reserves the right to change specifications and prices at any time and without notice. Therefore, prior to designing this product into a system, it is necessary to check with austriamicrosystems for current information. This product is intended for use in normal commercial applications.

Copyright © 2009 austriamicrosystems. Trademarks registered ®. All rights reserved. The material herein may not be reproduced, adapted, merged, translated, stored, or used without the prior written consent of the copyright owner. To the best of its knowledge, austriamicrosystems asserts that the information contained in this publication is accurate and correct. However, austriamicrosystems shall not be liable to recipient or any third party for any damages, including but not limited to personal injury, property damage, loss of profits, loss of use, interruption of business or indirect, special, incidental or consequential damages, of any kind, in connection with or arising out of the furnishing, performance or use of the technical data herein. No obligation or liability to recipient or any third party shall arise or flow out of austriamicrosystems rendering of technical or other services.