



Chipsmall Limited consists of a professional team with an average of over 10 year of expertise in the distribution of electronic components. Based in Hongkong, we have already established firm and mutual-benefit business relationships with customers from,Europe,America and south Asia,supplying obsolete and hard-to-find components to meet their specific needs.

With the principle of “Quality Parts,Customers Priority,Honest Operation,and Considerate Service”,our business mainly focus on the distribution of electronic components. Line cards we deal with include Microchip,ALPS,ROHM,Xilinx,Pulse,ON,Everlight and Freescale. Main products comprise IC,Modules,Potentiometer,IC Socket,Relay,Connector.Our parts cover such applications as commercial,industrial, and automotives areas.

We are looking forward to setting up business relationship with you and hope to provide you with the best service and solution. Let us make a better world for our industry!



## Contact us

Tel: +86-755-8981 8866 Fax: +86-755-8427 6832

Email & Skype: info@chipsmall.com Web: www.chipsmall.com

Address: A1208, Overseas Decoration Building, #122 Zhenhua RD., Futian, Shenzhen, China





## Datasheet

DS000563

# AS6200C

## Digital Temperature Sensor

v2-01 • 2018-Apr-13

---

# Content Guide

<b>1</b>	<b>General Description..... 3</b>	6.2	Detailed Register Description ..... 12
1.1	Key Benefits & Features ..... 3	6.3	Serial Interface ..... 22
1.2	Applications ..... 3	<b>7</b>	<b>Application Information ..... 30</b>
1.3	Block Diagram ..... 4	7.1	External Components ..... 31
<b>2</b>	<b>Ordering Information..... 5</b>	<b>8</b>	<b>Package Drawings &amp; Markings... 32</b>
<b>3</b>	<b>Pin Assignment ..... 6</b>	<b>9</b>	<b>Revision Information..... 34</b>
3.1	Pin Diagram..... 6	<b>10</b>	<b>Legal Information ..... 35</b>
3.2	Pin Description ..... 6		
<b>4</b>	<b>Absolute Maximum Ratings ..... 8</b>		
<b>5</b>	<b>Typical Operating Characteristics 9</b>		
5.1	Analog System Parameters ..... 9		
5.2	Digital System Parameters..... 10		
<b>6</b>	<b>Register Description..... 11</b>		
6.1	Register Overview ..... 11		

# 1 General Description

The AS6200C IC is a high accuracy temperature sensor system that communicates via a 2 wire digital bus with other devices. It consists of a Si bandgap temperature sensor, an ADC and a digital signal processor.

It has a very high temperature accuracy ( $\pm 0.2^{\circ}\text{C}$  between  $-10^{\circ}\text{C}$  to  $20^{\circ}\text{C}$ ) and an ultra-low power consumption (low operation and quiescent current) which makes it ideally suited for mobile/battery powered applications.

The AS6200C is an easy to integrate and use solution, featuring a factory-calibrated sensor, integrated linearization and the possibility to use 2 different I<sup>2</sup>C addresses, enabling to use two AS6200C devices on one bus.

Additionally the AS6200C temperature sensor system also features an alert functionality, which triggers e.g. an interrupt to protect devices from excessive temperatures.

## 1.1 Key Benefits & Features

The benefits and features of AS6200C, are listed below:

**Figure 1:**  
Added Value of Using AS6200C

Benefits	Features
High Measurement Accuracy	$\pm 0.2^{\circ}\text{C}$ ( $-10^{\circ}\text{C}$ to $20^{\circ}\text{C}$ )
	$\pm 0.25^{\circ}\text{C}$ ( $-20^{\circ}\text{C}$ to $-10^{\circ}\text{C}$ )
	$\pm 0.4^{\circ}\text{C}$ ( $-30^{\circ}\text{C}$ to $-20^{\circ}\text{C}$ and $20^{\circ}\text{C}$ to $50^{\circ}\text{C}$ )
	$\pm 1^{\circ}\text{C}$ remaining operating temperature span
Low Power Consumption	6 $\mu\text{A}$ @Operation (typical, @ 4 Hz) 0.1 $\mu\text{A}$ @Standby (typical)
Supply Voltage Range	1.8 – 3.6 V
Small PCB Footprint	1.5 mm x 1 mm (WLCSP)

## 1.2 Applications

- Cold chain monitoring data loggers
- Cold chain storage systems
- Refrigerators and cooling systems

### 1.3 Block Diagram

The functional blocks of this device are shown below:

**Figure 2 :**  
**Functional Blocks of AS6200C**

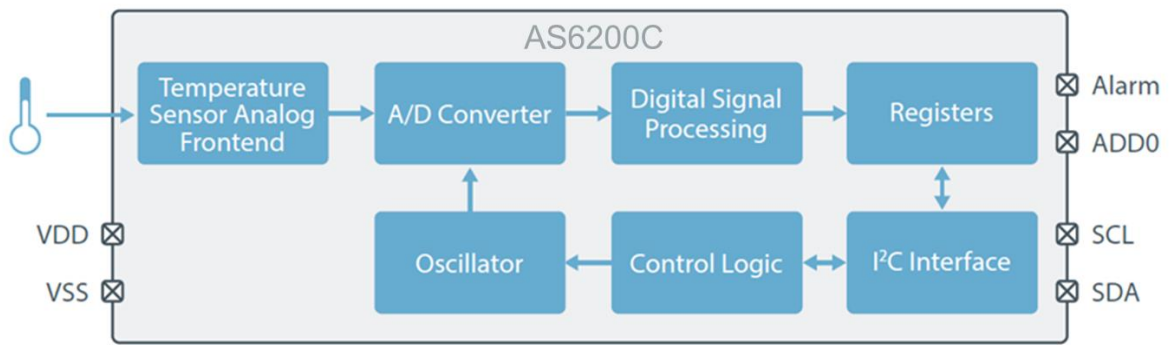

In Figure 2 the functional blocks are depicted. The sensing element for sensing the temperature is a Si bipolar transistor. The analog signal of the sensing element is converted into a digital signal by the A/D converter and the signal is further processed by a digital signal processor and written into the registers. The registers can be accessed via the serial bus interface (I<sup>2</sup>C bus).

---

## 2 Ordering Information

---

Ordering Code	Package	Marking	Delivery Form	Delivery Quantity
AS6200C-AWLM-S	WLCSP	AS6MCC	Tape & Reel	500 pcs/reel
AS6200C-AWLT-L	WLCSP	AS6MCC	Tape & Reel	5000 pcs/reel

# 3 Pin Assignment

## 3.1 Pin Diagram

Figure 3:  
Pin Assignment WLCSP

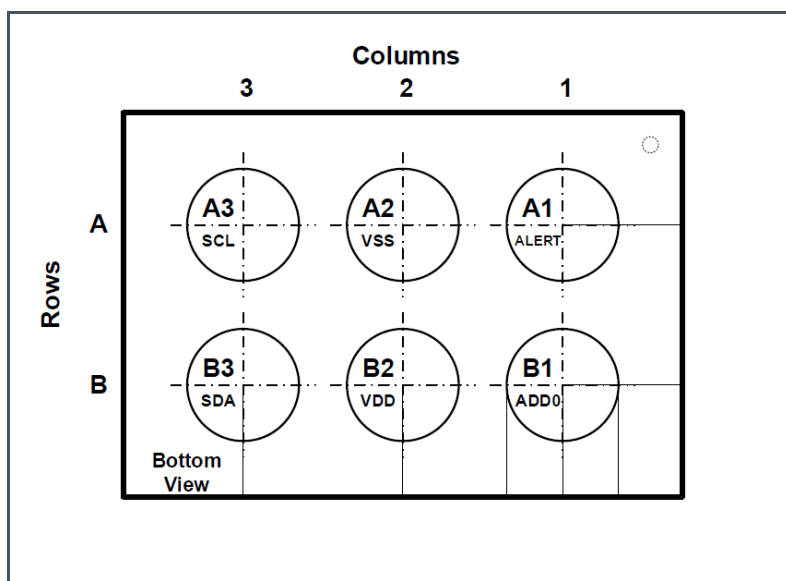

In Figure 3 the pin assignment of the WLCSP package is shown. The viewing side is from the bottom. The A1 pin is also marked with a point on the top side

## 3.2 Pin Description

Figure 4:  
Pin Description of AS6200C (WLCSP)

Pin Number	Pin Name	Pin Type <sup>(1)</sup>	Description
A1	ALERT	DO_OD	Alert output (interrupt)
A2	VSS	S	Ground Pin
A3	SCL	DI_S	Serial Interface Clock
B1	ADD0	DI_S	Address Select Pin
B2	VDD	S	Positive Supply Voltage

Pin Number	Pin Name	Pin Type <sup>(1)</sup>	Description
B3	SDA	DI_SOD	Serial Interface Data

- (1) Explanation of abbreviations:
- S Digital Input
  - DO\_OD Digital Output open drain
  - DI\_S Digital Schmitt Trigger Input
  - DIO\_SOD Digital Schmitt Trig

In Figure 4 the pins of AS6200C are described. External pull up resistors are necessary for the pins “Alert”, “SDA” & “SCL”. The pin “ADD0” must not be left unconnected (refer to the bus address section for further details).



## 4 Absolute Maximum Ratings

Stresses beyond those listed under “Absolute Maximum Ratings” may cause permanent damage to the device. These are stress ratings only. Functional operation of the device at these or any other conditions beyond those indicated under “Operating Conditions” is not implied. Exposure to absolute maximum rating conditions for extended periods may affect device reliability.

**Figure 5**  
**Absolute Maximum Ratings of AS6200C**

Symbol	Parameter	Min	Max	Unit	Comments
<b>Electrical Parameters</b>					
$V_{SUP} / V_{GND}$	Supply Voltage to Ground	-0.3	4	V	
$V_{IN}$	Input Pin Voltage to Ground	-100	100	V	
<b>Electrostatic Discharge</b>					
$ESD_{HBM}$	Electrostatic Discharge HBM		2000	V	
<b>Temperature Ranges and Storage Conditions</b>					
$T_A$	Operating Ambient Temperature	-40	125	°C	
$R_{THJA}$	Junction to Ambient Thermal Resistance			°C/W	
$T_J$	Operating Junction Temperature		125	°C	
$T_{STRG}$	Storage Temperature Range	- 55	125	°C	
$T_{BODY}$	Package Body Temperature		260	°C	IPC/JEDEC J-STD-020 <sup>(1)</sup>
$R_{HNC}$	Relative Humidity (non-condensing)	5	85	%	
MSL	Moisture Sensitivity Level		1		

- (1) The reflow peak soldering temperature (body temperature) is specified according to IPC/JEDEC J-STD-020 “Moisture/Reflow Sensitivity Classification for Nonhermetic Solid State Surface Mount Devices.”

# 5 Typical Operating Characteristics

The AS6200C is a complete sensor system that has an integrated sensing element, the analog frontend, the A/D converter and the digital signal processing part.

The digital signal processing part consists of the signal processor, the registers and the serial bus interface.

## 5.1 Analog System Parameters

**Figure 6:**  
Analog System Parameters of AS6200C

Parameter	Symbol	Min	Typ	Max	Unit	Note
Supply Voltage	Vdd	1.8 2.0	3.0 3.0	3.6 3.6	V	T= 0°C to 125°C T= -40°C to 125°C
Temperature Range	T	-40		125	°C	
Standby current consumption	IDD		0.1 0.3	0.4 0.9	µA	T= -40°C to 65°C T= 65°C to 125°C
Current Consumption (4 conversion /s)	IDD		6	7 16	µA	T= -40°C to 65°C Serial bus inactive T= 65°C to 125°C Serial bus inactive
Accuracy <sup>(1)</sup>	T_ERR			-1.0	1.0	T= -40°C to -30°C
				-0.4	0.4	T= -30°C to -20°C
				-0.2	0.25	T= -20°C to -10°C
				-0.2	0.2	T= -10°C to 20°C
				-0.4	0.4	T= 20°C to 50°C
		-1.0	1.0	1.0	T= 50°C to 125°C	
Resolution	N		12		Bits	
Conversion Time	TS	24	32	40	ms	
Conversion Rate	NS		0.25 1 4 8	0.35 1.35 5.5 10.7	Conv/s	CR[1:0]=00 CR[1:0]=01 CR[1:0]=10 CR[1:0]=11

(1) The accuracy is based on measurements and reflects 3 σ statistics.

In Figure 6 an overview of the analog system parameters is given.

The current consumption for less than 4 conversions per second is lower than the values given in Figure 6.

## 5.2 Digital System Parameters

**Figure 7:**  
**Digital System Parameters of AS6200C**

Parameter	Symbol	Pins	Min	Max	Unit	Note
High level input voltage	V_IH	SCL, ADD0	0.7 * VDD		V	
Low level input voltage	V_IL	SCL,ADD0		0.3 * VDD	V	
Low level output voltage	V_OL	Alert		VSS+0.4	V	I_OL=3mA
High level input voltage	V_IH	SDA	0.7 * VDD		V	
Low level input voltage	V_IL	SDA		0.3*VDD	V	
Low level output voltage	V_OL	SDA		VSS+0.4	V	
Tristate leakage current	I_OZ	SDA	-10	10	μA	to VSS

In Figure 7 an overview of the digital system parameters is given.

# 6 Register Description

## 6.1 Register Overview

**Figure 8 :**  
Register Map with Serial Interface

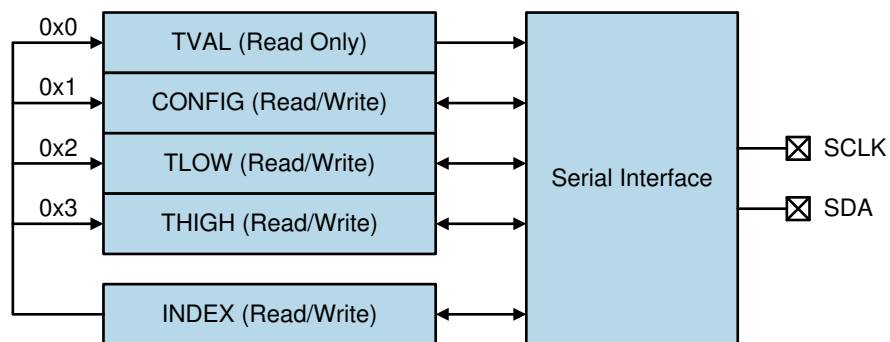

In Figure 8 the registers that the device contains are shown.

With the use of the index register, it is possible to address the specific register. The index register is an 8-bit register, where only bits 0 and 1 are used as shown in Figure 9 and all other bits are set to 0 and read only

### 6.1.1 Index Register

**Figure 9:**  
Index Register

Bit	Bit Name	Default	Access
0	Address Bit	0	RW
1	Address Bit	0	RW
2	Reserved	0	RO
3	Reserved	0	RO
4	Reserved	0	RO
5	Reserved	0	RO
6	Reserved	0	RO
7	Reserved	0	RO

**Figure 10:**  
**Register Map**

Address	Symbol	Register	Description
0x0	TVAL	Temperature Register	Contains the temperature value
0x1	CONFIG	Configuration Register	Configuration settings of the temperature sensor
0x2	TLOW	T <sub>LOW</sub> Register	Low temperature threshold value
0x3	THIGH	T <sub>HIGH</sub> Register	High temperature threshold value

The 2 bit addresses in the index register define the access to the registers shown in Figure 10. This means that in order to access the different registers, the index register must be set accordingly. With the exception of the TVAL register (which contains the temperature value data), all registers are read/write accessible.

## 6.2 Detailed Register Description

### 6.2.1 Configuration Register (Address 0x1)

**Figure 11:**  
**CONFIGURATION Register**

Addr: 0x1				
Bit	Bit Name	Default	Access	Bit Description
0	Reserved	0	RO	Reserved
1	Reserved	0	RO	Reserved
2	Reserved	0	RO	Reserved
3	Reserved	0	RO	Reserved
4	Reserved	0	RO	Reserved
5	AL	1	RO	ALERT Bit (AL)
6	CR	0	RW	Conversion RATE (CR)
7	CR	1	RW	Conversion RATE (CR)
8	SM	0	RW	Sleep Mode (SM)
9	IM	0	RW	Interrupt Mode (IM)
10	POL	0	RW	Polarity (POL)
11	CF	0	RW	Consecutive Faults (CF)
12	CF	0	RW	Consecutive Faults (CF)
13	Reserved	0	RO	Reserved

Addr: 0x1				
Bit	Bit Name	Default	Access	Bit Description
14	Reserved	1	RO	Reserved
15	SS	0	RW	Single Shot

The configuration register is a 16-bit register which defines the operation modes of the device. Any read/write operations processes the MSB byte first.

In Figure 11 the configuration register is shown. The bits 0-4 and 13-14 are not to be used and are set to read only. The explanation of the other bits are detailed in the following sections.

### 6.2.2 Alert Bit

The alert bit can be used to easily compare the current temperature reading to the thresholds that can be set in the TLWO and THIGH registers.

If the polarity bit is set to 0, the AL bit is read as 1 until the converted temperature value exceeds the defined value in the high temperature threshold register THIGH for the number of defined consecutive faults (bits CF). Such an event causes the AL bit to toggle to 0 and the value is kept until the converted temperature value falls below the defined value in the low temperature threshold register TLOW for the number of defined consecutive faults. If this condition is met, the AL bit is reset to 1.

The polarity bit (POL) defines the active state of the alert bit as depicted in the following figure.

The alert bit has the same setting as the alert output as long as the device is configured for the comparator mode.

**Figure 12:**  
**State Diagram of the Alert Bit**

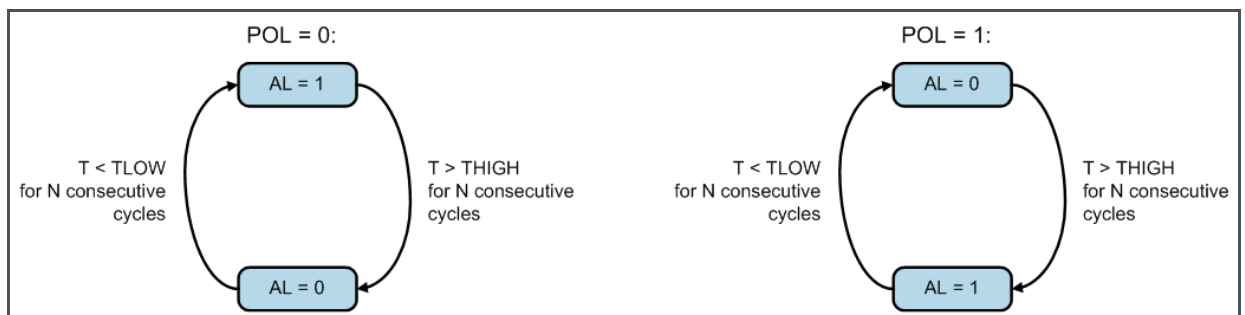

### 6.2.3 Conversion Rate Bits

The conversion rate bits define the number of executed temperature conversions per time unit. Additional readouts of the temperature register between conversions are possible but not recommended because the value is changed only after a conversion is finished.

Values of 125ms, 250ms, 1s and 4s per conversion can be configured while the default rate is set to 250ms. This corresponds to a value of 4 conversions per second. The following table summarizes the different configuration settings:

**Figure 13:**  
Conversion Rate Configuration

Conversion Rate Bits		Conversion Rate	Conversion Frequency
Bit 7	Bit 6		
0	0	4 s	0.25 Hz
0	1	1 s	1 Hz
1	0	250 ms	4 Hz (default)
1	1	125 ms	8 Hz

The device immediately starts a conversion after a power-on sequence and provides the first result after typ. 32ms (max. 40ms). A higher power consumption occurs during the actual conversion while the device stays in the standby mode after a finished conversion until the next conversion is activated as shown in the following figure.

**Figure 14:**  
Conversion Sequence

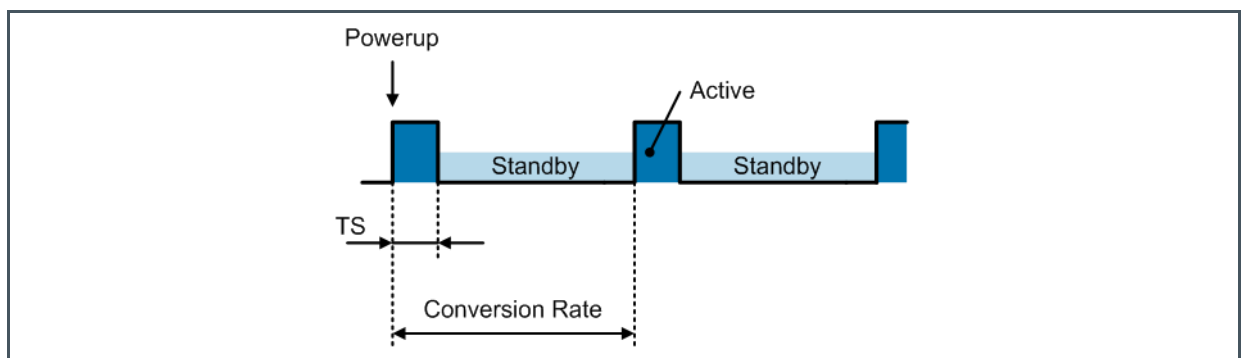

### 6.2.4 Sleep Mode

The sleep mode is activated by setting the bit SM in the configuration register to 1. This shuts the device down immediately and reduces the power consumption to a minimum value.

The serial interface is the only active circuitry in the sleep mode in order to provide access to the digital registers.

After resetting the SM bit to 0, the device enters the continuous conversion mode.

**Figure 15:**  
**Sleep Mode Configuration**

Sleep Mode Bit	Operation Mode
0	Continuous Conversion Mode
1	Sleep Mode

### 6.2.5 Interrupt Mode

The interrupt mode bit defines whether the device operates in the temperature comparator mode or the interrupt mode. This defines the operation of the ALERT output as described in the polarity section bit.

**Figure 16:**  
**Interrupt Mode Configuration**

Interrupt Mode Bit	Configuration Mode
0	Comparator Mode
1	Interrupt Mode

The comparator mode is characterized that if the temperature value exceeds the THIGH value, the alert output is changed (e.g. from high to low if the polarity bit is set to 0 and vice versa). The alert output stays in that condition until the measured temperature drops below the defined TLOW value.

The interrupt mode is characterized that it changes the alert output as soon as the measured temperature crosses the THIGH or TLOW value threshold.

The alert bit has the same setting as the alert output if the device is set to comparator mode.



Figure 17:  
Alert Output Functionality

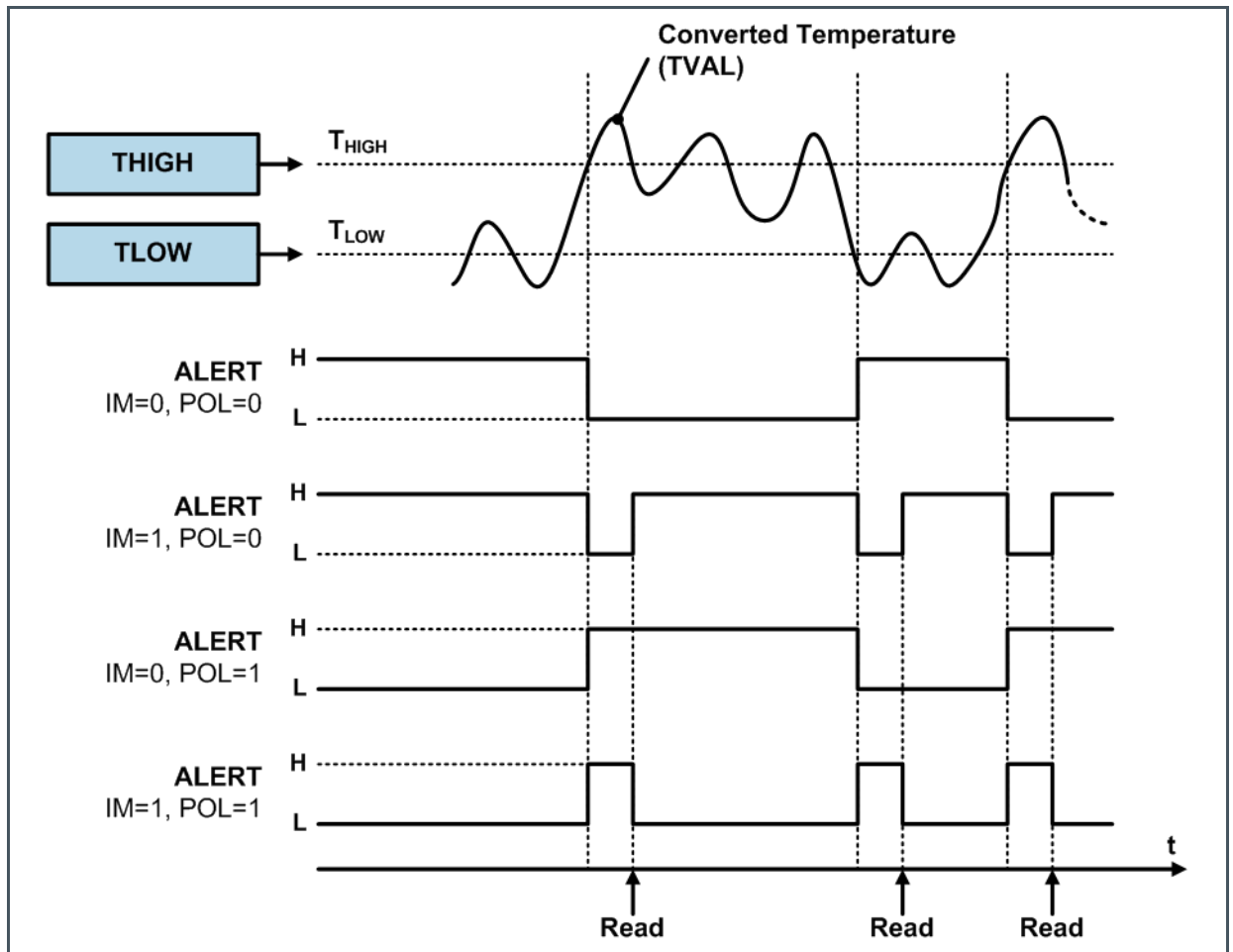

### 6.2.6 Polarity Bit

The polarity bit configures the polarity of the ALERT output. If the polarity bit is cleared, the ALERT output is low active while it becomes high active if the polarity bit is set to '1'.

Figure 18:  
Polarity Bit Configuration

Polarity Bit	ALERT Output
0	Active low
1	Active high

### 6.2.7 Consecutive Faults

A fault condition persists if the measured temperature either exceeds the configured value in register THIGH or falls below the defined value in register TLOW. As a result, the ALERT pin indicates the fault condition if a defined number of consecutive temperature readings meets this fault condition. The number of consecutive faults are defined with two bits (12 and 11) and prevent a false alert if environmental temperature noise is present. The register configuration is shown in the following table.

**Figure 19:**  
Consecutive Faults Bit Settings

Consecutive Fault Bits		Consecutive Faults (N)
Bit 12	Bit 13	
0	0	1
0	1	2
1	0	3
1	1	4

### 6.2.8 Single Shot Conversion

The device features a single shot measurement mode if the device is in sleep mode (SM=1). By setting the “Single Shot-bit” to 1, a single temperature conversion is started and the SS-bit can be read as 1 during the active conversion operation. Once the conversion is completed, the device enters the sleep mode again and the SS-bit is set to 0. The single shot conversion allows very low power consumption since a temperature conversion is executed on demand only. This allows a user defined timing of the temperature conversions to be executed and is used if the consecutive operation mode is not required.

As the device exhibits a very short conversion time, the effective conversion rate can be increased by setting the single shot bit repetitively after a conversion has finished. However, it has to be ensured that the additional power is limited, otherwise self-heating effects have to be considered.

**Figure 20:**  
Single Shot Conversion Bit Settings

Single Shot Bit	Conversion
0	No conversion ongoing/ conversion finished
1	Start single shot conversion / conversion ongoing

## 6.2.9 High and Low Limit Registers

If the comparator mode is configured (IM=0), the ALERT output becomes active if the temperature equals or exceeds the defined value in register THIGH for the configured number of consecutive faults (N). This configuration is defined by the field CF in the configuration register. The ALERT output remains assigned until the converted temperature value equals or falls below the defined value in register TLOW for the same number of consecutive fault cycles.

If the interrupt mode is configured (IM=1), the ALERT output becomes active if the temperature equals or exceeds the defined value in register THIGH for the configured number of consecutive fault cycles. It remains active until a read operation is executed on any register. The ALERT output is also cleared if the device is set into sleep mode by setting bit SM in the configuration register.

Once the ALERT output is cleared, it is activated again only if the temperature value falls below the configured value in register TLOW. It remains active unless a read operation has taken place.

This sequence is repeated unless the device is set into the comparator mode or reset by the General Call Reset command. This reset command clears the interrupt mode bit and consequently puts the device into the comparator mode.

The sequential behavior is summarized in the following figure.

Figure 21:  
Alert Operation Modes

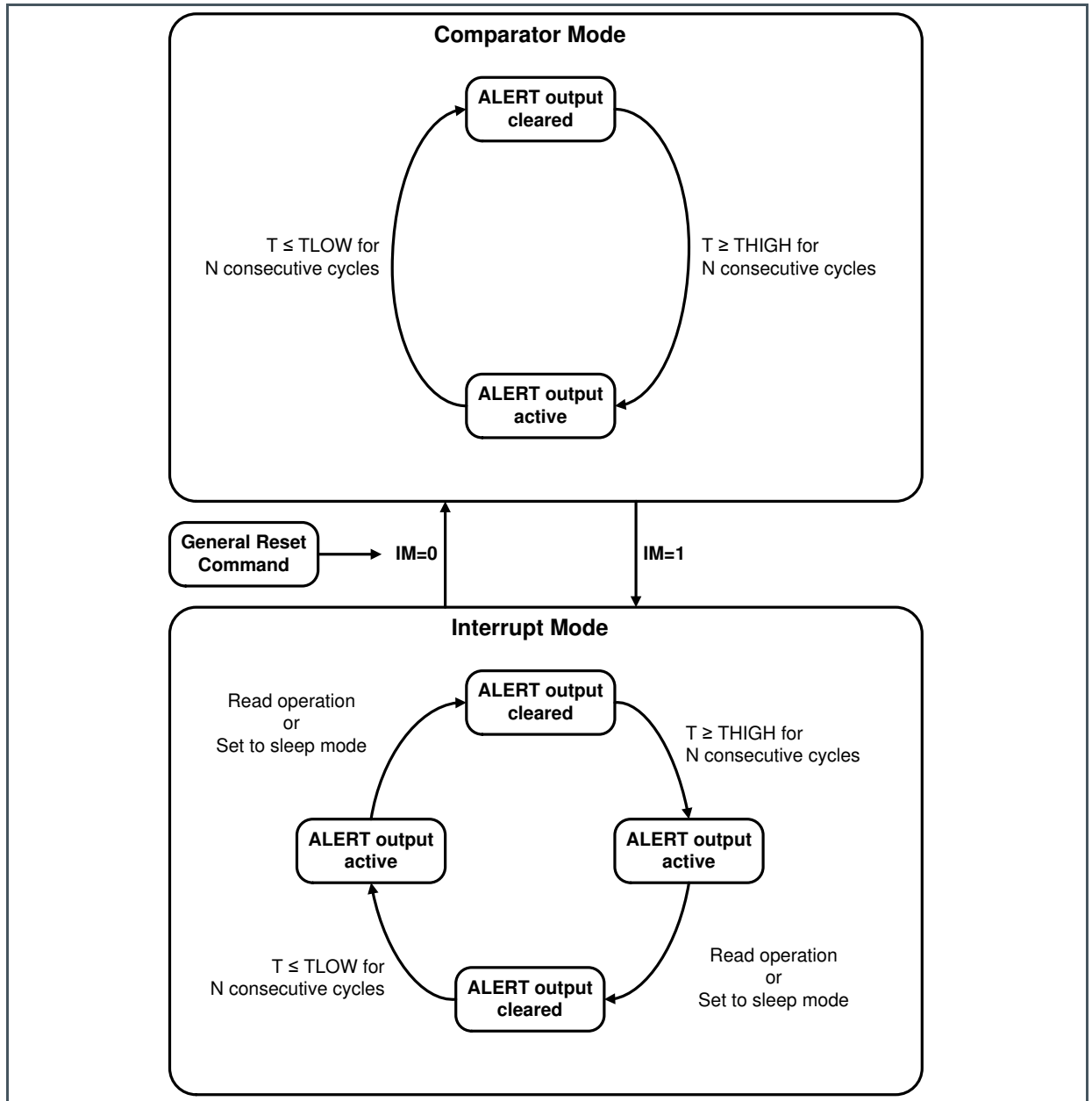

The following table defines the content of the registers TLOW and THIGH. For data transmission, the MSB byte is transmitted first, followed by the LSB byte. The data format for representing the threshold temperatures is equal to the temperature register (TVAL). After a power-up, the registers are initialized with the following default values:

**Figure 22:**  
Default Values for THIGH and TLOW

Register	Temperature	Binary Value
TLOW	75 °C	L11 to L0 = 0100 1011 0000
THIGH	80 °C	H11H0 = 0101 0000 0000

The following table defines the register bits of the THIGH and TLOW register.

**Figure 23:**  
Register Bit Settings for THIGH/TLOW

Addr: 0x2 / 0x3			
Bit	Bit Name for TLOW	Bit Name for THIGH	Access
0	0	0	RW
1	0	0	RW
2	0	0	RW
3	0	0	RW
4	L1	H1	RW
5	L2	H2	RW
6	L3	H3	RW
7	L4	H4	RW
8	L5	H5	RW
9	L6	H6	RW
10	L7	H7	RW
11	L8	H8	RW
12	L9	H9	RW
13	L10	H10	RW
14	L11	H11	RW
15	L12	H12	RW

## 6.2.10 Temperature Register (Address 0x0)

**Figure 24:**  
Temperature Value Register

Addr: 0x0	
Bit	Bit Name
0	0
1	0
2	0
3	0
4	T1
5	T2
6	T3
7	T4
8	T5
9	T6
10	T7
11	T8
12	T9
13	T10
14	T11
15	T12

The temperature register contains the digitally converted temperature value and can be read by setting the index pointer to the TVAL register (0x0).

Two consecutive bytes must be read to obtain the complete temperature value. The MSB byte (Bits 15 to 8) is transmitted upon the first read access and the LSB byte (Bits 7 to 0) is transmitted after the second read access. The least significant bits 3 to 0 are set to 0.

A temperature value is represented as a two complement value in order to cover also negative values. After power-up, the temperature value is read as 0°C until the first conversion has been completed. One LSB corresponds to 0.0625°C.

The binary values can be calculated according to the following formulas:

Positive values:  $|\text{Value}| / \text{LSB}$

Negative values:  $\text{Complement} (|\text{Value}| / \text{LSB}) + 1$

Example 75°C:

$$75^{\circ}\text{C} / 0.0625^{\circ}\text{C} = 1200 = \text{Binary } 0100\ 1011\ 0000 = \text{Hex } 4\text{B}0$$

Example -40°C:

$$\overline{|-40^{\circ}\text{C}|} / 0.0625^{\circ}\text{C} + 1 = \overline{640} + 1 = \text{Binary } \overline{0010\ 1000\ 0000} + 1 = 1101\ 0111\ 1111 + 1 = 1101\ 10000\ 0000 = \text{Hex } \text{D}80$$

**Figure 25:**  
Temperature Conversion Examples

Temperature (°C)	Digital Output (Binary)	Digital Output (Hex)
100.0	0110 0100 0000	640
75.0	0100 1011 0000	4B0
50.0	0011 0010 0000	320
25.0	0001 1001 0000	190
0.125	0000 0000 0010	002
0.0625	0000 0000 0001	001
0.0	0000 0000 0000	000
-0.0625	1111 1111 1111	FFF
-0.125	1111 1111 1110	FFE
-25.0	1110 0111 0000	E70
-40.0	1101 1000 0000	D80

## 6.3 Serial Interface

The device employs a standard I<sup>2</sup>C-serial bus.

### 6.3.1 Bus Description

A data transfer must be invoked by a master device (e.g. microcontroller) which de-fines the access to the slave device. The master device defines and generates the serial clock (SCL) and the start/stop conditions.

In order to address a specific device, a START condition has to be generated by the master device by pulling the data line (SDA) from a logic high level to a logic low level while the serial clock signal (SCL) is kept at high level.

After the start condition, the slave address byte is transmitted which is completed with a ninth bit which indicates a read (bit='1') or a write operation (bit='0') respectively. All slaves read the data on the rising edge of the clock. An acknowledge signal is generated by the addressed slave during the ninth clock pulse. This acknowledge signal is produced by pulling the pin SDA to a low level by the selected slave.

Subsequently, the byte data transfer is started and finished by an acknowledge bit. A change in the data signal (SDA) while the clock signal (SCL) is high causes a START or STOP condition. Hence, it must be ensured such a condition is prevented during a data transfer phase.

After completing the data transfer, the master generates a STOP condition by pulling the data line (SDA) from low level to high level while the clock signal (SCL) is kept at high level.

### 6.3.2 Data Interface

A bus connection is created by connecting the open drain input/output lines SDA and SCL to the two wire bus. The inputs of SDA and SCL feature Schmitt-trigger inputs as well as low pass filters in order to suppress noise on the bus line. This improves the robustness against spikes on the two wire interface.

Both fast transmission mode (1kHz to 400kHz) and high-speed transmission mode (1kHz to 3.4MHz) are employed to cover different bus speed settings.

Any data transfer transmits the MSB first and the LSB as last bit.

### 6.3.3 Bus Address

A slave address consists of seven bits, followed by a data direction bit (read/write operation). The slave address can be selected from a pool of two different address settings by connecting the input pin ADD0 to an appropriate signal as summarized in the following table.

The ADD0 must not be left unconnected.

**Figure 26:**  
I<sup>2</sup>C Address Select Configuration

ADD0 connection	Device Address (bin)	Device Address (hex)
VSS	0100 1000	0x48
VDD	0100 1001	0x49

### 6.3.4 Read/Write Operation

In order to access an internal data register, the index register must be written in advance. This register contains the actual register address and selects the appropriate register for an access. A typical



transfer consists of the transmission of the slave address with a write operation indication, followed by the transmission of the register address and is finalized with the actual register content data transfer. This implies that every write operation to the temperature sensor device requires a value for the index register prior to the transmission of the actual register data.

The index register defines the register address for both the write and read operation. Consequently, if a read operation is executed, the register address is taken from the index register which was defined from the last write operation.

If a different register needs to be read, the index register has to be written in advance to define the new register address. This is accomplished by transmitting the slave address with a low R/W bit, followed by the new content of the index register. Subsequently, the master provokes a START condition on the bus and transmits the slave address with a high R/W bit in order to initiate a read operation.

Since the index register always keeps its last value, reads can be executed repetitively on the same register.

Similarly to the byte transfer where the MSB is transmitted first, the transfer of a 16-bit word is executed by a two byte transfer whereas the MSB byte is always transmitted first.

### 6.3.5 Slave Operation

The device employs a slave functionality only (slave transmitter and slave receiver) and cannot be operated as a bus master. Consequently, the device never actively drives the SCL line.

### 6.3.6 Slave Receiver Mode

Any transmission is invoked by the master device by transmitting the slave address with a low R/W bit. Subsequently, the slave device acknowledges the reception of the valid address by pulling the ninth bit to a low level. Following to acknowledge, the master transmits the content of the index register. This transfer is again acknowledged by the slave device. The next data byte(s) are written to the actual data register which is selected by the index register while each transfer is acknowledged upon a completed transfer by the slave device. A data transfer can be finished if the master transmits a START or a STOP condition on the bus.

### 6.3.7 Slave Transmitter

The master transmits the slave address with a high R/W bit. In turn, the slave acknowledges a valid slave address. Subsequently, the slave transmits the MSB byte of the actual selected data register by the index register. After the MSB byte transmission, acknowledge is sent by the master. Afterwards, the LSB byte is transmitted by the slave which is also acknowledged by the master after the completed transmission. The data transfer can be terminated by the master by transmitting a Not-Acknowledge after the transmitted slave data or by invoking a START or a STOP condition on the bus.

### 6.3.8 Alert Function

If the device is configured for an interrupt mode operation (IM=1), the ALERT output can be used as an alert signal.

If the polarity bit is set to '0' (POL='0'), the alert condition bit is set to '0' in case the temperature has exceeded the configured value in register THIGH. Accordingly, the alert condition bit is set to '1' if the temperature has fallen below the configured value in register TLOW.

If the polarity bit is set to '1' (POL='1'), the alert condition bit is inverted. The following table summarizes the status of the alert condition bit with different alert conditions and polarity configurations.

**Figure 27:**  
**Alert Condition Bit**

Polarity Bit	Alert Condition	Alert Condition Bit (AC-Bit)
0	$T \geq \text{THIGH}$	0
0	$T \leq \text{TLOW}$	1
1	$T \geq \text{THIGH}$	1
1	$T \leq \text{TLOW}$	0

### 6.3.9 High Speed Mode

The bus operation is limited to 400kHz unless a high speed command is issued by the master device as the first byte after a START condition. This switches the bus to a high speed operation which allows data transfer frequencies up to 3.4MHz. Such a command is not acknowledged by the slave but the input filter time constants on the serial interface (SDA and SCL) are adapted to allow the higher transfer rate.

After a high speed command, the slave address is transmitted by the master in order to invoke a data transfer. The bus keeps operating at the higher operating frequency until the master issues a STOP condition on the serial bus. Upon the reception of the STOP condition by the slave, the input filters are switched to their initial time constants which allow lower transfer rates only.

**Figure 28:**  
**Summary of Bus Commands**

Command	Address	Data Value
Device Initialization		0000 0110
General Address Acquire	Not supported	
High Speed Command		0000 1xxx