

Chipsmall Limited consists of a professional team with an average of over 10 year of expertise in the distribution of electronic components. Based in Hongkong, we have already established firm and mutual-benefit business relationships with customers from,Europe,America and south Asia,supplying obsolete and hard-to-find components to meet their specific needs.

With the principle of “Quality Parts,Customers Priority,Honest Operation,and Considerate Service”,our business mainly focus on the distribution of electronic components. Line cards we deal with include Microchip,ALPS,ROHM,Xilinx,Pulse,ON,Everlight and Freescale. Main products comprise IC,Modules,Potentiometer,IC Socket,Relay,Connector.Our parts cover such applications as commercial,industrial, and automotives areas.

We are looking forward to setting up business relationship with you and hope to provide you with the best service and solution. Let us make a better world for our industry!



Contact us

Tel: +86-755-8981 8866 Fax: +86-755-8427 6832

Email & Skype: info@chipsmall.com Web: www.chipsmall.com

Address: A1208, Overseas Decoration Building, #122 Zhenhua RD., Futian, Shenzhen, China

AS7211

Smart Daylighting Manager with Fully Integrated Daylight Sensor, Control and Network Interfaces

General Description

The AS7211 Smart Lighting Manager device is an intelligent, photopic-sensor based light manager that enables automatic daylight level adaptation and energy conservation for next generation lighting systems. It is part of the **ams** Cognitive Lighting™ family of products that enable lights to be “aware” and adapt to their surroundings and autonomously meet human and energy conservation lighting needs.

The AS7211 is equipped with an advanced Cognitive Light Engine (CLE) to optimize daylight harvesting and control either dimming ballasts or LED drivers. Ambient light sensing is achieved by way of integrated nano-optic deposited interference filters which deliver high-stability over time and temperature. The LGA package includes a built in aperture to control light entering the sensor array.

A direct connection to a local sensor networks (LSN) enables integration with external occupancy sensors, dimmers or bridges. The AS7211 connects to standard 0-10V dimmers inputs and drives 0-10V dimming ballasts/drivers for fluorescent lighting or LED drivers for LED lighting. A UART interface is provided for remote configuration, control and management of the CLE. This UART interface responds to simple Smart Lighting Commands.

[Ordering Information](#) and [Content Guide](#) appear at end of datasheet.

Key Benefits & Features

The benefits and features of AS7211, Smart Daylighting Manager with Fully Integrated Daylight Sensor, Control and Network Interfaces are listed below:

Figure 1:
Added Value of Using the AS7211

Benefits	Features
<ul style="list-style-type: none"> Accurate control of daylight-responsive lighting 	<ul style="list-style-type: none"> Calibrated photopic sensing for direct lux compensation for daylighting systems
<ul style="list-style-type: none"> Automatic lumen maintenance over temperature and time 	<ul style="list-style-type: none"> Autonomous lumen output adjustment independent of LED aging effects
<ul style="list-style-type: none"> Direct serial interface for connection to standard networks 	<ul style="list-style-type: none"> Simple UART interface for connection to network hardware clients for protocols such as Bluetooth, ZigBee and WiFi
<ul style="list-style-type: none"> Simple lamp or luminaire configuration and commissioning using defined command set 	<ul style="list-style-type: none"> Smart Lighting Command Set (SLCS) uses simple text-based commands to control and configure a wide variety of functions
<ul style="list-style-type: none"> Compatible with standard dimmer controls and occupancy sensors 	<ul style="list-style-type: none"> Directly interfaces to 0-10V dimmer controls and standard occupancy sensors
<ul style="list-style-type: none"> Directly interfaces to LED driver or FETs 	<ul style="list-style-type: none"> Built-in PWM generator to dim LED lamps and luminaires 12-bit resolution for precise dimming down to 1%
<ul style="list-style-type: none"> Directly interfaces to ballast via 0-10V 	<ul style="list-style-type: none"> 0-10V analog output for control of conventional fluorescent or other dimming ballasts
<ul style="list-style-type: none"> Small package, wide operating range with critical optics built-in 	<ul style="list-style-type: none"> 20-pin LGA package 4.5mm x 4.7mm x 2.5mm with integrated aperture -40°C to 85°C

Applications

Sense ambient light, dim and maintain brightness of luminaires and lamps in local loop control, automatic lumen maintenance, flexible network connectivity and simple control of luminaires and lamps.

- LED and fluorescent luminaires, troffers, high-bays
- Track-head and downlights
- LED and fluorescent replacement lamps
- Energy efficient installations, such as California Title 24 type energy code requirements

Block Diagram

Figure 2:
Functional Blocks of AS7211

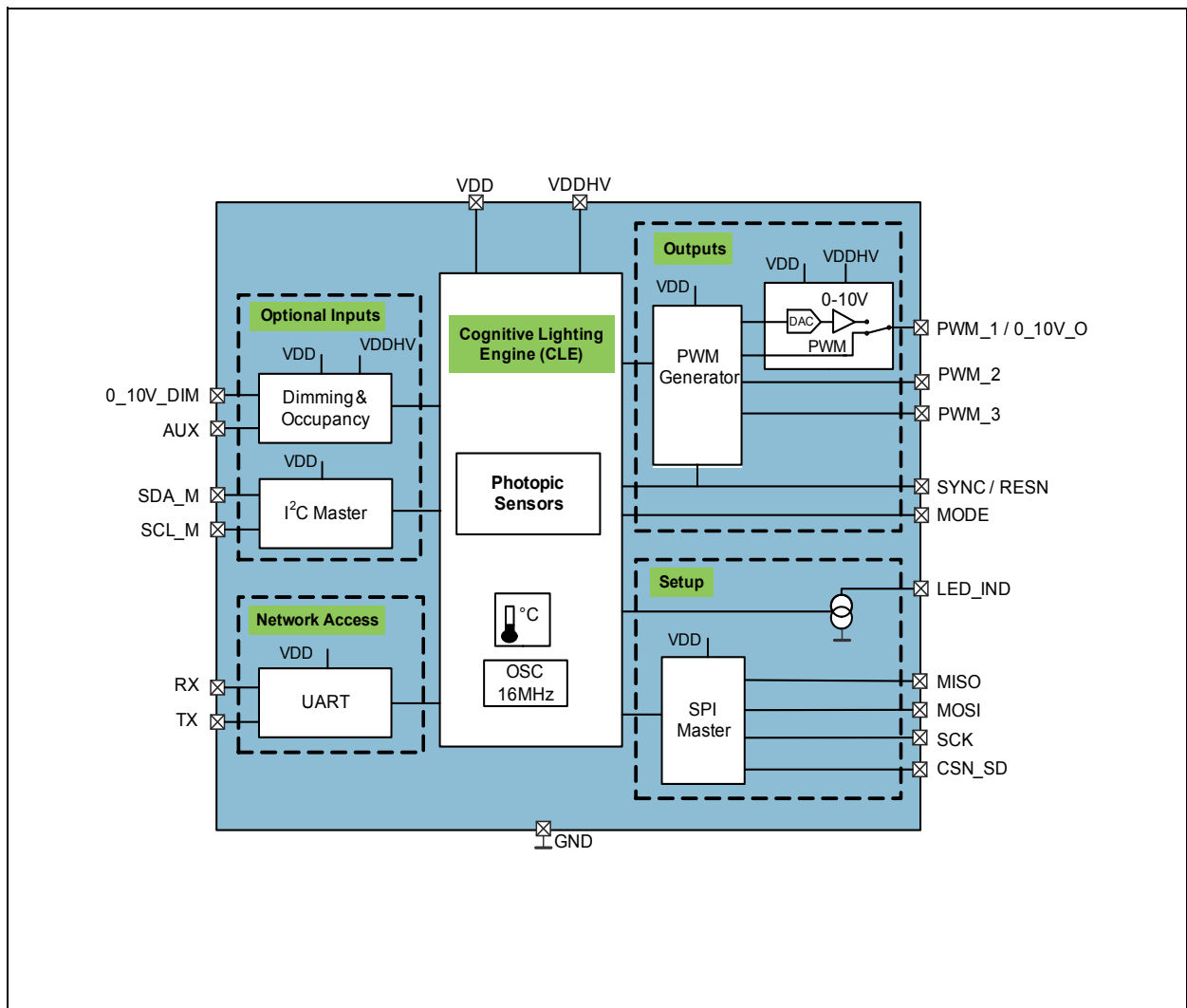

Block Diagram: The AS7211 provides closed loop ambient Daylight sensing and PWM tuning while interfacing to Local and Network controls.

Pin Assignments

Figure 3:
Pin Diagram of AS7211 (Top View)

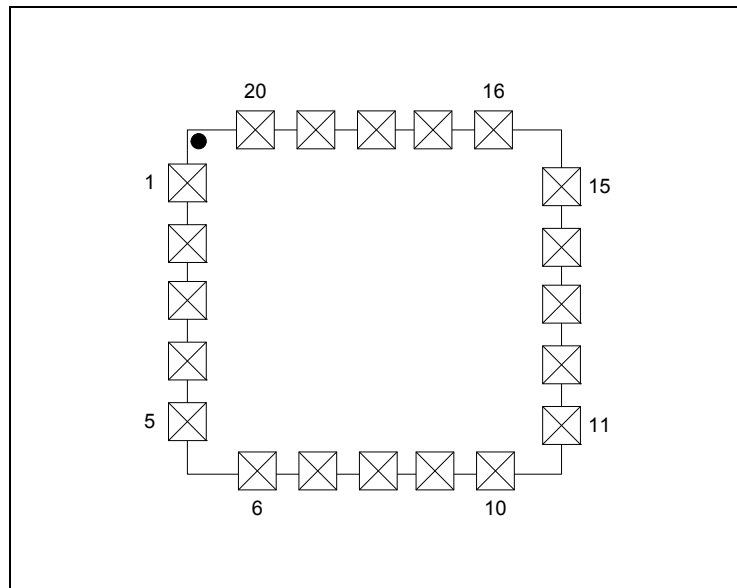

Figure 4:
Pin Description of AS7211 (20 pin LGA)

Pin Number	Pin Name	Description
1	PWM_3	Digital PWM 3
2	SYNC	SYNC input
	RESN	Reset pin, active low
3	SCK	SPI serial clock
4	MOSI	SPI MOSI
5	MISO	SPI MISO
6	CSN_EE	Chip select for the required external serial flash memory, active low
7	CSN_SD	Chip select for SD Card interface, active low
8	AUX	Auxiliary mode input pin
9	SCL_M	I ² C master clock pin
10	SDA_M	I ² C master data pin
11	RX	UART RX pin
12	TX	UART TX pin
13	0_10V_DIM	0-10V input dimming pin

Pin Number	Pin Name	Description
14	VDDHV	High Voltage Supply
15	MODE	Mode selection pin
16	GND	Ground
17	VDD	Low Voltage Supply
18	LED_IND	LED Driver output for Indicator LED, current sink
19	PWM_1	Digital PWM 1
	0_10V_O	0-10V output pin
20	PWM_2	Digital PWM 2

Absolute Maximum Ratings

Stresses beyond those listed under [Absolute Maximum Ratings](#) may cause permanent damage to the device. These are stress ratings only. Functional operation of the device at these or any other conditions beyond those indicated under [Electrical Characteristics](#) is not implied. Exposure to absolute maximum rating conditions for extended periods may affect device reliability. The device is not designed for high energy UV (ultraviolet) environments, including upward looking outdoor applications, which could affect long term optical performance.

Figure 5:
Absolute Maximum Ratings

Symbol	Parameter	Min	Max	Units	Comments
Electrical Parameters					
V_{DD_MAX}	Supply Voltage VDD	-0.3	5	V	Pin VDD to GND, Low Voltage pin
V_{DDHV_MAX}	Supply Voltage VDDHV	-0.3	20	V	Pin VDDHV to GND, High Voltage pin
V_{DD_IO}	Input/Output Pin Voltage	-0.3	VDD + 0.3	V	Low Voltage pins to GND
V_{DDHV_IO}	Input/Output Pin Voltage	-0.3	VDDHV + 0.3	V	High Voltage pins to GND
I_{SCR}	Input Current (latch-up immunity)	± 100		mA	JESD78D
Electrostatic Discharge					
ESD_{HBM}	Electrostatic Discharge HBM	± 1000		V	JS-001-2014
ESD_{CDM}	Electrostatic Discharge CDM	± 500		V	JSD22-C101F
Temperature Ranges and Storage Conditions					
T_{strg}	Storage Temperature	-40	85	°C	
T_{body}	Package Body Temperature		260	°C	IPC/JEDEC J-STD-020. The reflow peak soldering temperature (body temperature) is specified according IPC/JEDEC J-STD-020 "Moisture/Reflow Sensitivity Classification for Non-hermetic Solid State Surface Mount Devices"
RH_{NC}	Relative Humidity (non-condensing)	5	85	%	
MSL	Moisture Sensitivity Level	3			Represents a 168 hour max. floor lifetime

Electrical Characteristics

All limits are guaranteed with $V_{DD} = 3.3V$, $V_{DDHV} = 12V$, $T_{AMB} = 25^{\circ}C$. The parameters with min and max values are guaranteed with production tests or SQC (Statistical Quality Control) methods.

If V_{DD} and V_{DDHV} are to be the same voltage, they must be sourced by the same 2.97-3.6V supply.

Figure 6:
Electrical Characteristics

Symbol	Parameter	Conditions	Min	Typ	Max	Unit
General Operating Conditions						
V_{DD}	Low Voltage Operating Supply		2.97	3.3	3.6	V
V_{DDHV}	High Voltage Operating Supply		V_{DD}	12	15	V
T_{AMB}	Operating Temperature		-40	25	85	$^{\circ}C$
I_{VDD}	Operating Current				5	mA
Internal RC Oscillator						
F_{OSC}	Internal RC Oscillator Frequency		15.7	16	16.3	MHz
$t_{JITTER}^{(1)}$	Jitter	@25 $^{\circ}C$			1.2	ns
0-10V Output (0_10V_O pin)						
R_{OUT_10}	Resistive Load		1			k Ω
I_{S_10}	Source Current		10			mA
I_{SINK_10}	Sink Current		-10			mA
I_{LEAK_HV}	HV Output Leakage Current	$V_{IN}=12V$, DAC and PWM1 both disabled	0.73		1.6	mA
C_{LOAD_10}	Capacitive Load				100	pF
$V_{OUT_10}^{(2)}$	Output Swing		0		10	V
0-10V Input						
R_{IN_HV}	Analog Input Resistance	$V_{DDHV} \geq 12V$	138	200	315	k Ω

Symbol	Parameter	Conditions	Min	Typ	Max	Unit
Temperature Sensor						
D_{TEMP}	Absolute Accuracy of the Internal Temperature Measurement		-8.5		8.5	°C
Indicator LED						
I_{IND}	LED Current		1		8	mA
I_{ACC}	Accuracy of Current		-30		30	%
V_{LED}	Voltage Range of Connected LED	Vds of current sink	0.3			V
Digital Inputs and Outputs						
V_{IH}	CMOS Logic High Input		0.7* VDD		VDD	V
V_{IL}	CMOS Logic Low Input		0		0.3* VDD	V
V_{OH}	CMOS Logic High Output	I=1mA			VDD-0.4	V
V_{OL}	CMOS Logic Low Output	I=1mA			0.4	V
I_{IH}, I_{IL}	Logic Input Current	Vin=0V or VDD	-1		1	μA
$t_{RISE}^{(1)}$	Current Rise Time	C(Pad)=30pF			5	ns
$t_{FALL}^{(1)}$	Current Fall Time	C(Pad)=30pF			5	ns

Note(s):

1. Guaranteed, not production tested
2. For VDDHV>10.5, output max is 10V, else output max tracks VDDHV

Figure 7:
AS7211 I²C Master Timing Characteristics

Symbol	Parameter	Conditions	Min	Typ	Max	Unit
I²C Interface						
f _{SCLK}	SCL Clock Frequency			100	400	kHz
t _{BUF}	Bus Free Time Between a STOP and START		1.3			μs
t _{HD:STA}	Hold Time (Repeated) START		0.6			μs
t _{LOW}	LOW Period of SCL Clock		1.3			μs
t _{HIGH}	HIGH Period of SCL Clock		0.6			μs
t _{SU:STA}	Setup Time for a Repeated START		0.6			μs
t _{HD:DAT}	Data Hold Time		0		0.9	μs
t _{SU:DAT}	Data Setup Time		100			ns
t _R	Rise Time of Both SDA and SCL		20		300	ns
t _F	Fall Time of Both SDA and SCL		20		300	ns
t _{SU:STO}	Setup Time for STOP Condition		0.6			μs
C _B	Capacitive Load for Each Bus Line	CB — total capacitance of one bus line in pF			400	pF
C _{I/O}	I/O Capacitance (SDA, SCL)				10	pF

Figure 8:
I²C Master Timing Diagram

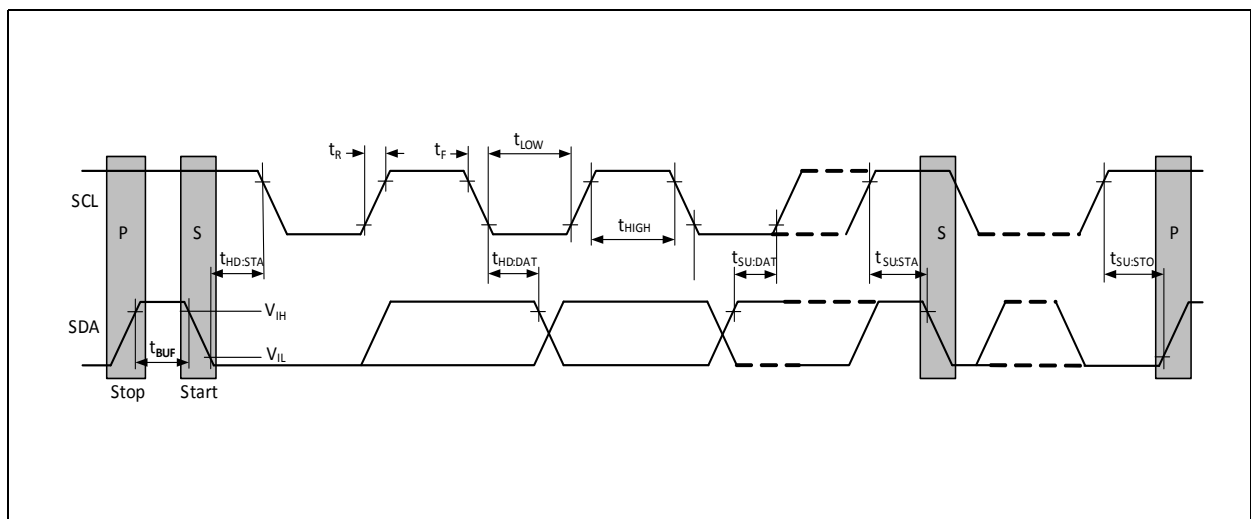

Figure 9:
AS7211 SPI Timing Characteristics

Symbol	Parameter	Conditions	Min	Typ	Max	Unit
SPI Interface						
f_{SCK}	Clock Frequency		0		16	MHz
t_{SCK_H}	Clock High Time		40			ns
t_{SCK_L}	Clock Low Time		40			ns
t_{SCK_RISE}	SCK Rise Time		5			ns
t_{SCK_FALL}	SCK Fall Time		5			ns
t_{CSN_S}	CSN Setup Time	Time between CSN high-low transition to first SCK high transition	50			ns
t_{CSN_H}	CSN Hold Time	Time between last SCK falling edge and CSN low-high transition	100			ns
t_{CSN_DIS}	CSN Disable Time		100			ns
t_{DO_S}	Data-Out Setup Time		5			ns
t_{DO_H}	Data-Out Hold Time		5			ns
t_{DI_V}	Data-In Valid		10			ns

Figure 10:
SPI Master Write Timing Diagram

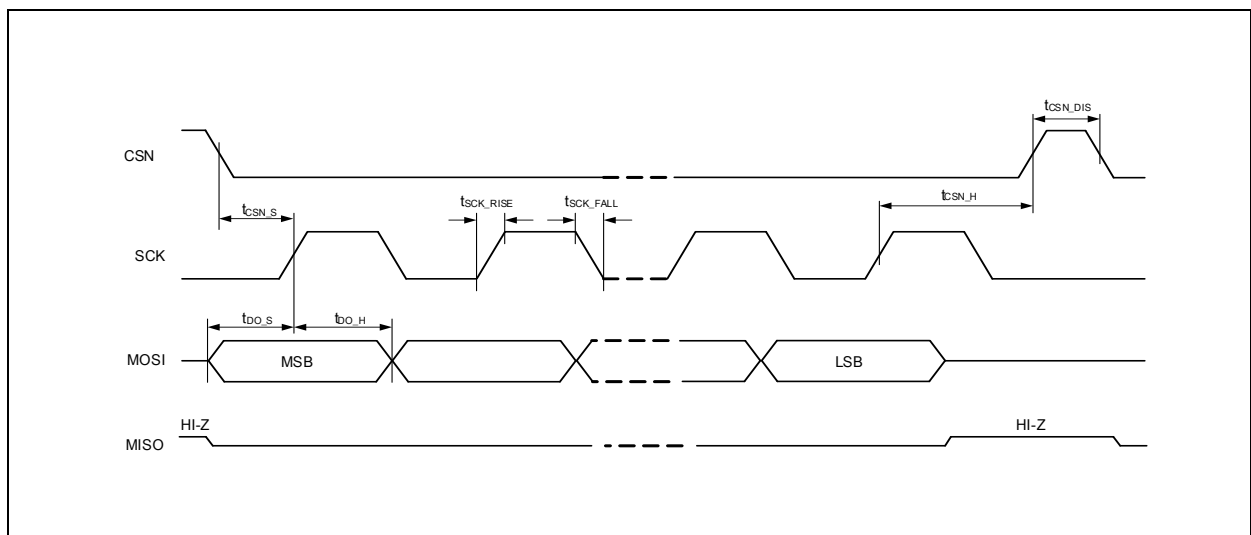

Figure 11:
SPI Master Read Timing Diagram

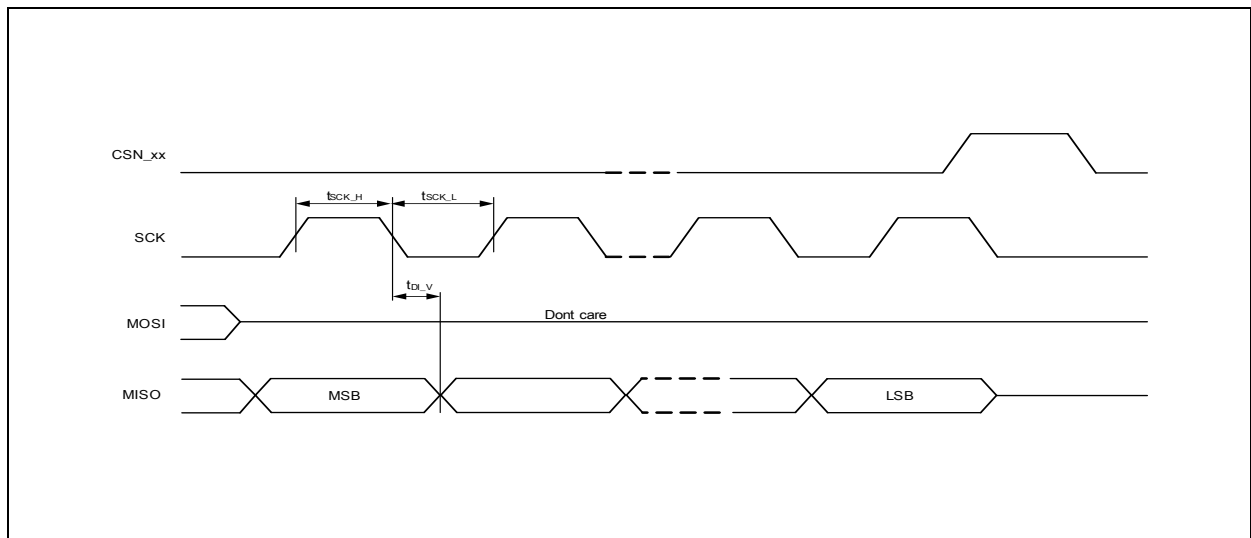

Figure 12:
Typical Spectral Responsivity

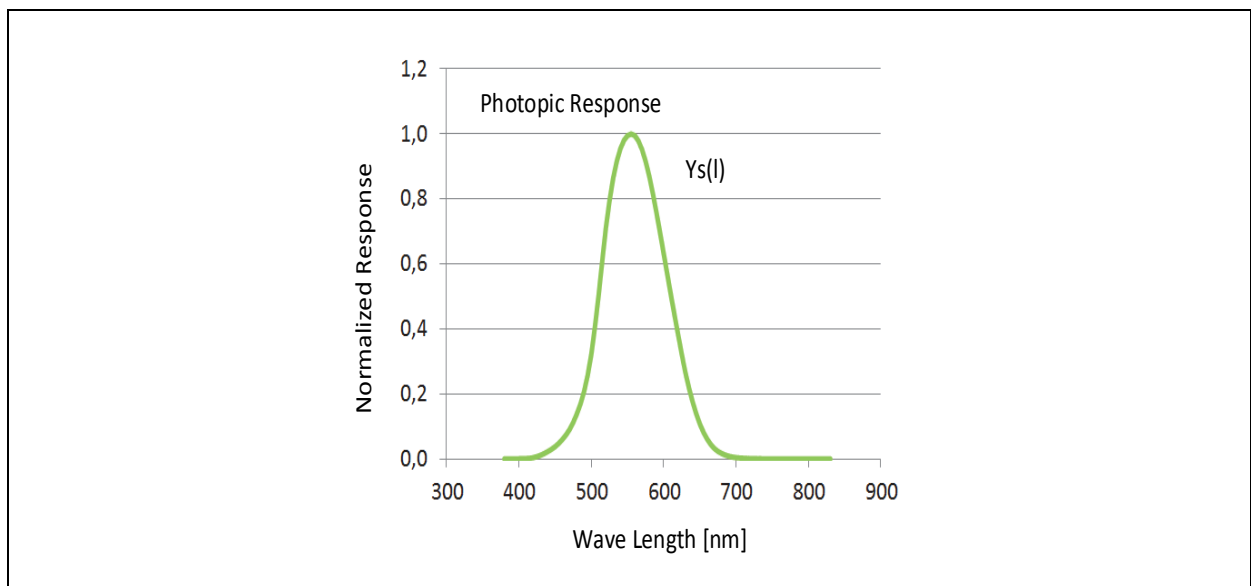

Figure 13:
AS7211 Optical Characteristics

Symbol	Parameter	Conditions	Min	Max	Unit
SO _{LUX} ⁽¹⁾	Sensor Output	White Light CCT=2700K, 3500K, 4500K, 5700K and incandescent	-10%	+10%	LUX
DR _{LUX} ⁽¹⁾	Dynamic Range		10	60000	LUX

Note(s):

1. Calibration and measurements are made using diffused light

Figure 14:
AS7211 LGA Package Field of View

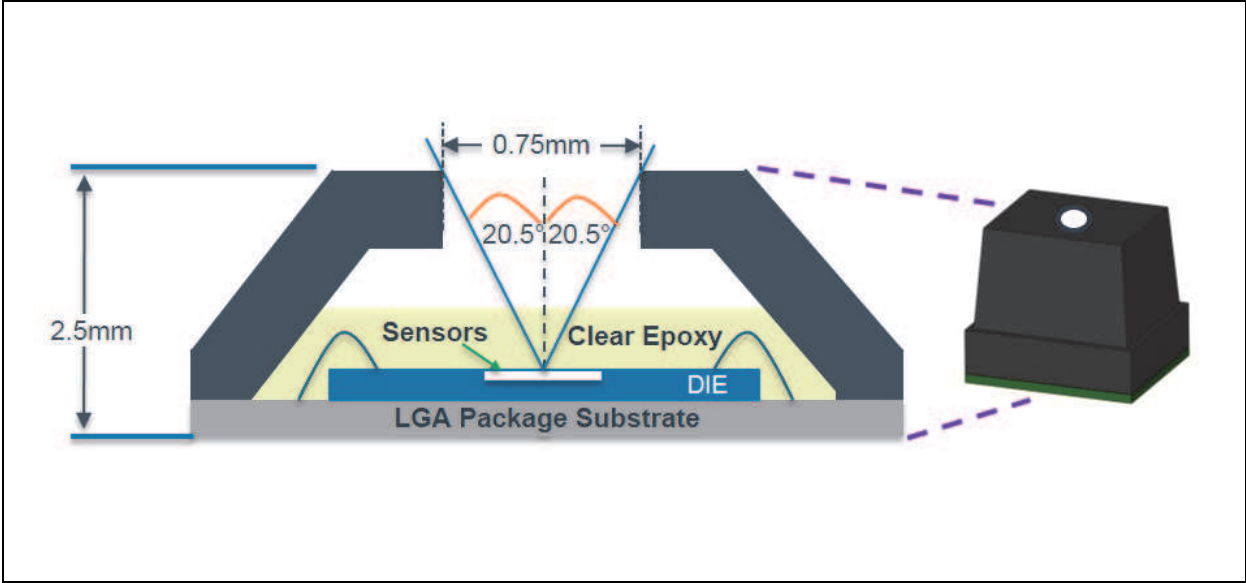

Detailed Description

AS7211 Smart Lighting Manager - Overview

The Cognitive Light Engine (CLE) is the “brains” of the Smart Lighting Manager. The CLE constantly processes information from the photopic sensor, network and inputs while controlling outputs. Initial setup and ongoing parameter storage is done by reading and writing an external serial flash memory via SPI bus.

A luminaire solution for daylighting requires only the AS7211. A luminaire solution with daylighting and lumen maintenance requires the addition of an **ams** TSL4531 single chip ambient light sensor, connected via I²C. Refer to the table in the Figure below.

Overall AS7211 timing generation uses an on chip 16MHz temperature compensated oscillator for master clock timing.

Refer to the separate AS7211 User Guide as well as the **ams** Smart Lighting Command Set document for additional usage and setup information.

Figure 15:
AS7211 Solution Chart

Solution Required		Device Orientation (from luminaire light source)	
Daylighting	Lumen Maintenance	AS7211	TSL4531 (optional)
✓	✗	↓ (into room)	✗ (not required)
✗	✓	↑ (into luminaire)	✗ (not required)
✓	✓	↑ (into luminaire)	↓ (into room)

Photopic Sensor

The photopic sensor, part of the AS7211 CLE, is a next-generation digital light sensor device which approximates the human eye response. The sensor contains an integrating analog-to-digital converter (16-bit resolution ADC), which integrates current from photodiodes. Upon completion of the conversion cycle, the result is transferred to the corresponding data registers. Transfers are double-buffered to ensure integrity of the data is maintained.

The photopic response is accomplished via silicon interference filters which are extremely stable over time and temperature. To ensure accuracy, the AS7211 LGA package contains an internal aperture that limits the sensor field of view (PFOV) of $\pm 20.5^\circ$, as shown in the figure above. External optics can be used as needed to expand or reduce this built in PFOV.

AS7211 Inputs

Figure 16:
VDDHV Based Settings for Inputs

VDDHV	Dimming
10.5-15V	Direct input for 0_10V_DIM, dimming input
2.97-10V ⁽¹⁾	External 5:1 resistor divider for 0-10V_DIM, dimming input ⁽²⁾

Note(s):

1. For VDDHV \leq 3.6V, VDDHV and VDD should be tied together.
2. With external dividers connected to 0-10V inputs, the max voltage to the device input is 2V.

For the AS7211, dimming can be accomplished from either the input pin (0_10V_DIM) or network commanded dimming using the AS7211 Smart Lighting Command set via the UART interface.

The typical example of a hardware controlled input is a standard 0-10V dimmer. The 0-10V DIM analog input signal is downscaled by the AS7211 with an internal voltage divider and converted to a 10 bit digital value, 0V=full dimming, 10V=no dimming. When using the internal voltage divider the voltage at the VDDHV pin has to be higher than 10V.

If a second supply is not available, VDDHV and VDD are tied together and the downscale has to be done using an external resistor divider. The maximum range in the downscaled input is limited to 2V. Hence to accept a full range 10V signal the input resistor divider has to be 5:1 ratio. Dependent on the level at pin VDDHV, the Smart Lighting Manager automatically selects either the internal or the external voltage divider. Refer to the Figures above and below. If the 0_10V_DIM pin is not used, an external resistor pull-up connecting it to VDDHV is recommended.

Figure 17:
0-10V Dimming Pin Input

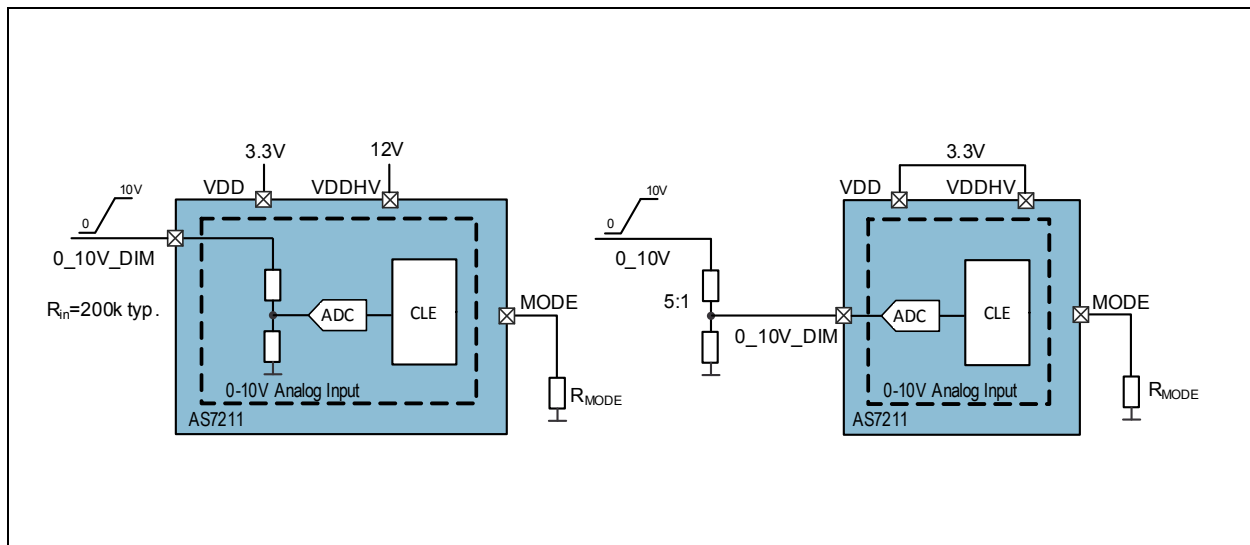

The auxiliary sensor input (AUX) can be configured for 0-10V analog sensing using a 5:1 resistor divider or can be configured for digital sensing. Both types are common for external occupancy sensors. If the AUX pin is not used, an external resistor pull-up connecting it to VDD is recommended. Refer to AS7211 User Guide as well as the **ams** Smart Lighting Command document for additional usage and setup information.

External sensors with native support by the AS7211 can be added via the I²C master interface for temperature, humidity, ambient light and other types of sensing.

Synchronization and Reset

Figure 18:
Synchronization and Reset Circuit

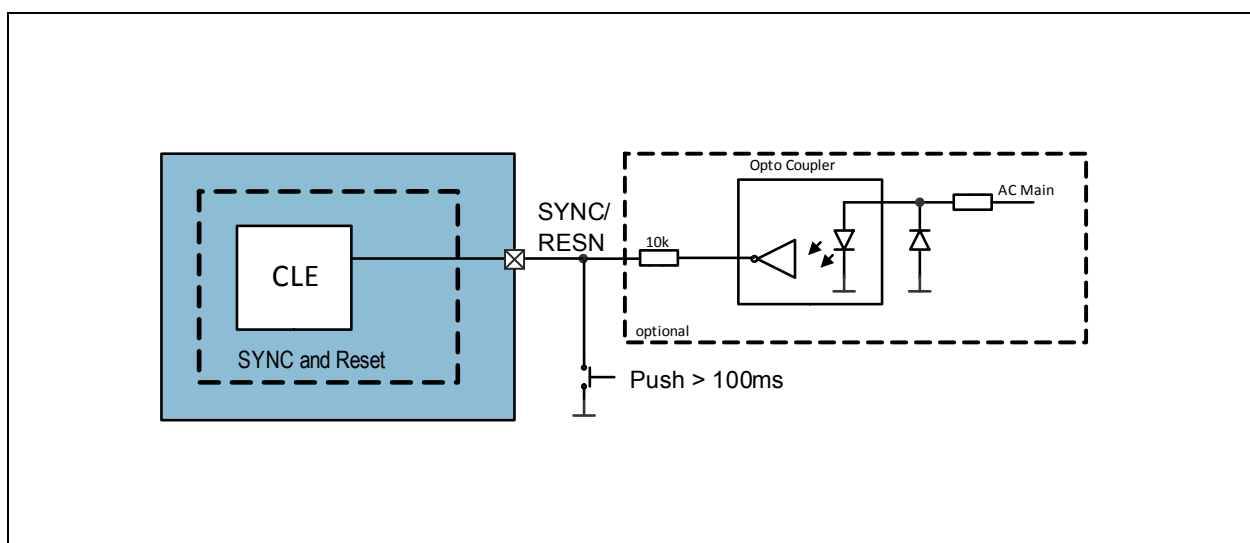

Synchronization and Reset Circuit: This figure shows the basic diagram when using reset and synchronization function together.

AS7211 provides optional synchronization of the PWMs. This sync signal can be derived from the AC mains so, for example, all luminaires in a room are synchronized to prevent beat frequency flicker. If the SYNC pin is left open, synchronization is automatically disabled.

Refer to the Figure above. When pulled down for more than 100ms the SYNC/RESN pin will reset the AS7211 Smart Lighting Manager. In this case the push-button “overrides” the output of the opto-coupler. Therefore a resistor should be placed in series with the opto-coupler.

AS7211 Outputs

The AS7211 outputs, used to control ballast dimming and/or LED string dimming, can be configured as either three PWM outputs or two PWMs and one analog output. The PWMs are 12 bit and are factory set to 888Hz. Refer to the Figure below.

The three PWM outputs, PWM_1, PWM_2 and PWM_3 all switch with the same frequency, but not simultaneously for better EMI performance.

The PWM_1 output can be set to either analog (0-VDDHV) or digital (0-VDDHV) dimming. Analog dimming range is 0-100%. Digital Dimming range is 0-100%. PWM2 and PWM3 track output 1 dimming level, but are always digital (0-100%).

To set the desired device operation MODE use the appropriate R_{MODE} resistor, also shown in the Figure below.

Figure 19:
Outputs

MODE	R_{MODE}	Setting	Outputs	
			PWM_1/0_10V_O	PWM_2 & PWM_3
0	100 Ω	0-10V analog	Analog 0-VDDHV ⁽¹⁾	Digital PWMs (0-VDD)
1	470 Ω	0-10V digital	Digital PWM (0-VDDHV) ⁽¹⁾	Digital PWMs (0-VDD)

Note(s):

1. For VDDHV>10.5, output max is 10V, else output max tracks VDDHV.

Indicator LED

An LED, connected to pin LED_IND, is used to indicate programming progress of the device. During programming of the AS7211 via an external SD card the indicator LED starts operation. When programming is finished the indicator LED is off. The LED_IND pin is set for 1mA operation by the AS7211 factory firmware, and is not under user control.

Refer to the separate **ams** document for a complete description of AS7211 Firmware Update Methodology.

UART and Smart Lighting Command Interface

The UART block implements the TX and RX signals as defined in the RS-232 / V.24 standard communication protocol.

UART Feature List

- Full Duplex Operation (Independent Serial Receive and Transmit Registers) with FIFO buffer of 8 bytes for each.
- Factory set to 115.2k Baud
- Supports Serial Frames with 8 Data Bits, no Parity and 1 Stop Bit.

Operation

Transmission

If data is available in the transmit FIFO, it will be moved into the output shift register and the data will be transmitted at the configured Baud Rate, starting with a Start Bit (logic zero) and followed by a Stop Bit (logic one).

Reception

At any time, with the receiver being idle, if a falling edge of a start bit is detected on the input, a byte will be received and stored in the receive FIFO. The following Stop Bit will be checked to be logic one.

Figure 20:
UART Protocol

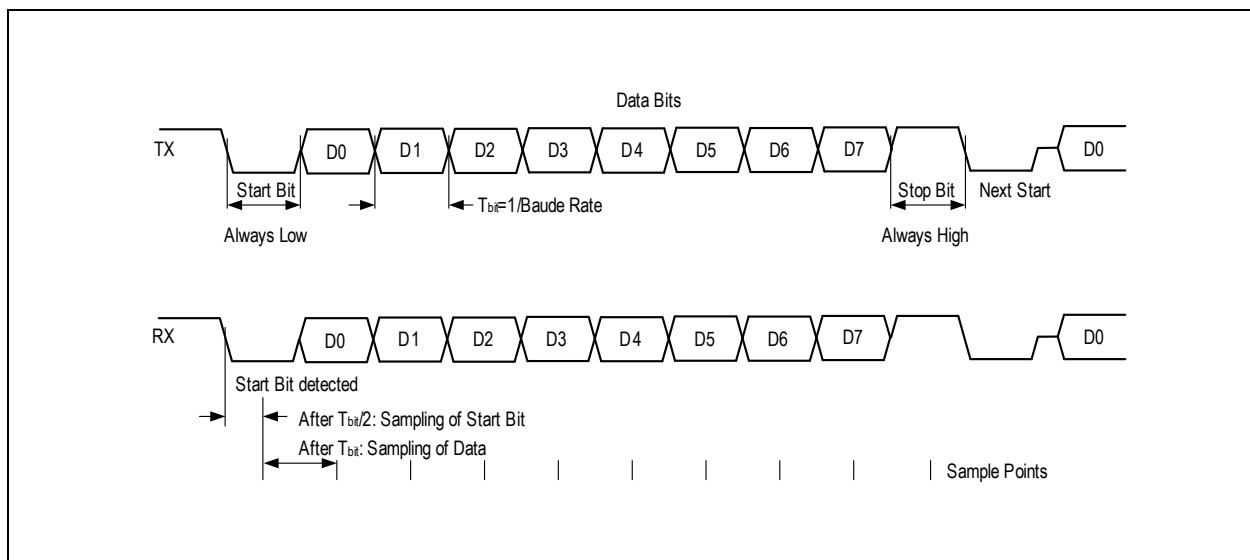

Smart Lighting Command Interface

The network interface on the Smart Lighting Manager supporting the Smart Lighting Commands is the UART interface. The Smart Lighting Manager adapts the concept of a simple command set for lighting control and configuration. The Smart Lighting Manager uses a text-based serial command interface as popularized by the “AT Command” model used in early Hayes modems.

For example:

Set the desired daylight LUX level target: ATLUXT = 500 >> OK

The “Smart Lighting Command Interface”, shown below between the network interface and the core of the system, provides access to the Smart Lighting Manager’s lighting control and configuration functions.

Figure 21:
Smart Lighting Command Interface

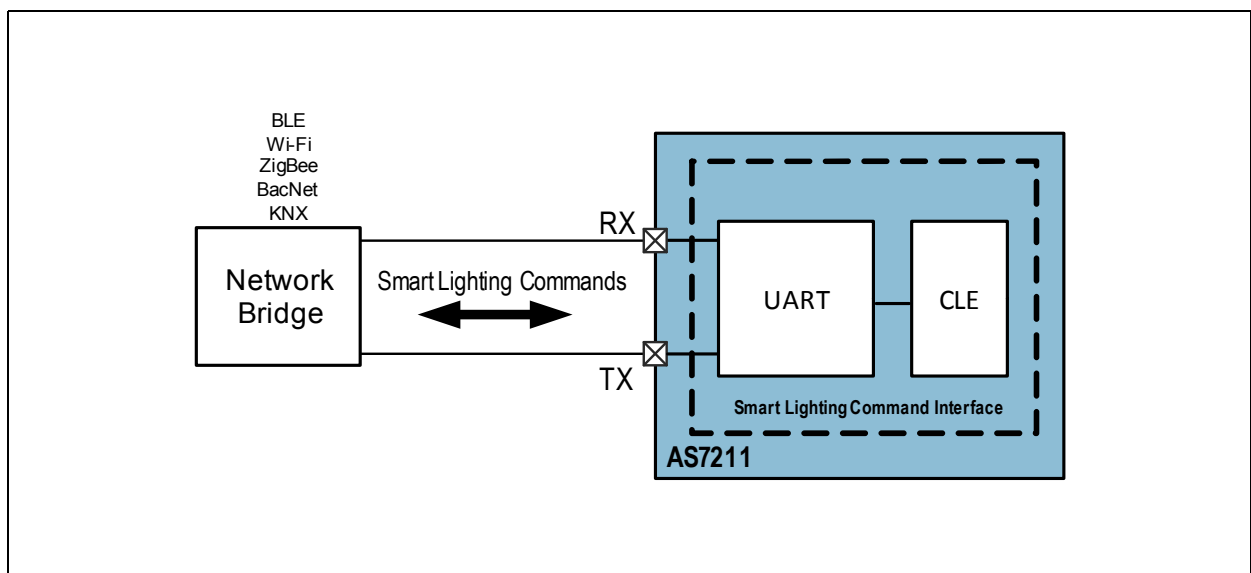

Refer to the separate **ams** AS7211 Smart Lighting Command Set document for complete command set and usage.

I²C Master Interface (Local Sensor Interface)

The I²C Master interface can be used to connect external sensors (such as Daylight, Occupancy, CO sensors, etc.). Refer to the separate **ams** Application note for external sensor usage with the AS7211.

I²C Feature List

- Clock is set to 100kHz
- 7+1-bit addressing mode.
- Write formats: Single-Byte-Write, Page-Write
- Read formats: Random-Read, Sequential-Read

I²C Protocol

Figure 22:
I²C Symbol Definition

Symbol	Definition	RW	Note
S	Start condition after stop	R	1 bit
Sr	Repeated start	R	1 bit
SW	Slave address for write	R	Slave address
SR	Slave address for read	R	Slave address
WA	Word address	R	8 bit
A	Acknowledge	W	1 bit
N	No Acknowledge	R	1 bit
Data	Data/write	R	8 bit
Data (n)	Data/read	W	8 bit
P	Stop condition	R	1 bit
WA++	Slave Increment word address	R	During acknowledge

The above I²C symbol definition table describes the symbols used in the following Read and Write descriptions.

I²C Write Access

Byte Write and Page Write formats are used to write data to the slave.

Figure 23:
I²C Byte Write

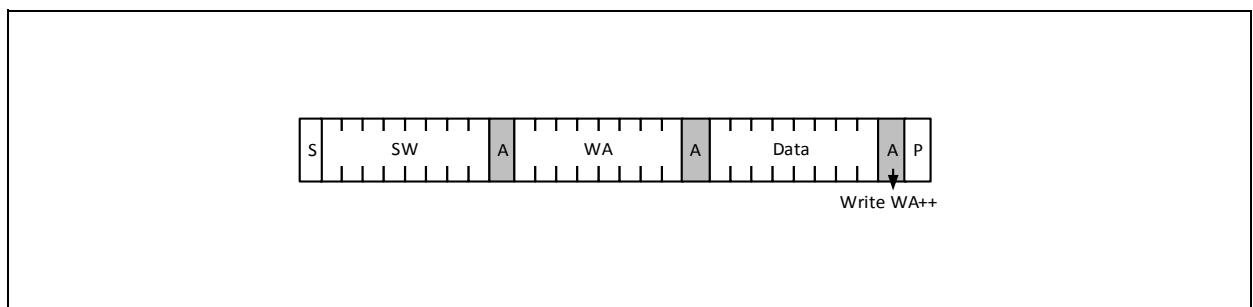
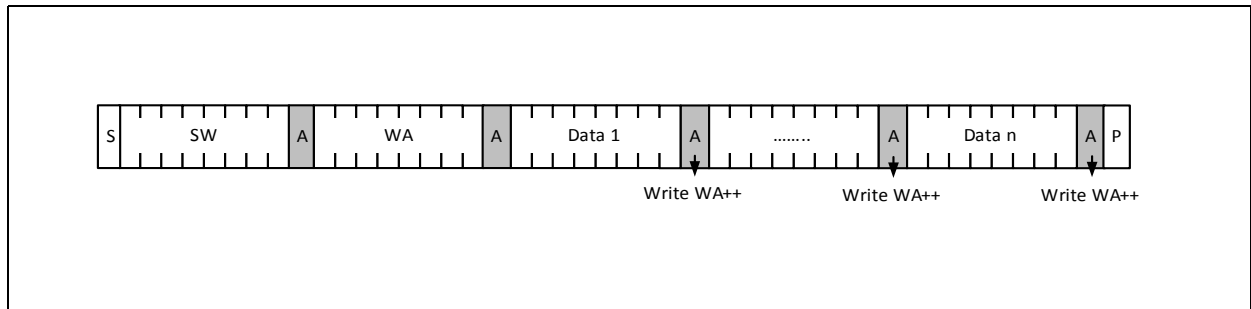

Figure 24:
I²C Page Write



The transmission begins with the START condition, which is generated by the master when the bus is in IDLE state (the bus is free). The device-write address is followed by the word address. After the word address any number of data bytes can be sent to the slave. The word address is incremented internally, in order to write subsequent data bytes on subsequent address locations.

For reading data from the slave device, the master has to change the transfer direction. This can be done either with a repeated START condition followed by the device-read address, or simply with a new transmission START followed by the device-read address, when the bus is in IDLE state. The device-read address is always followed by the 1st register byte transmitted from the slave. In Read Mode any number of subsequent register bytes can be read from the slave. The word address is incremented internally.

I²C Read Access

Random, Sequential and Current Address Read are used to read data from the slave.

Figure 25:
I²C Random Read

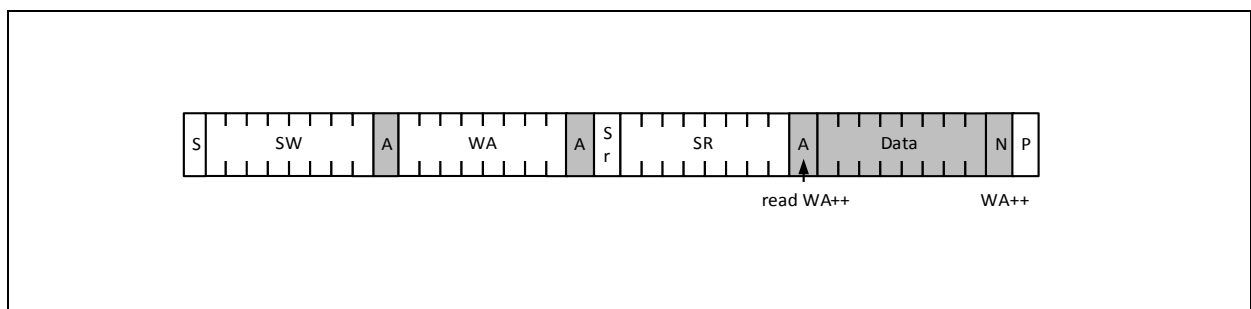

Random Read and Sequential Read are combined formats. The repeated START condition is used to change the direction after the data transfer from the master.

The word address transfer is initiated with a START condition issued by the master while the bus is idle. The START condition is followed by the device-write address and the word address.

In order to change the data direction a repeated START condition is issued on the 1st SCL pulse after the acknowledge bit of the word address transfer. After the reception of the device-read address, the slave becomes the transmitter. In this state the slave transmits register data located by the previous received word address vector. The master responds to the data byte with a not-acknowledge, and issues a STOP condition on the bus.

Figure 26:
I²C Sequential Read

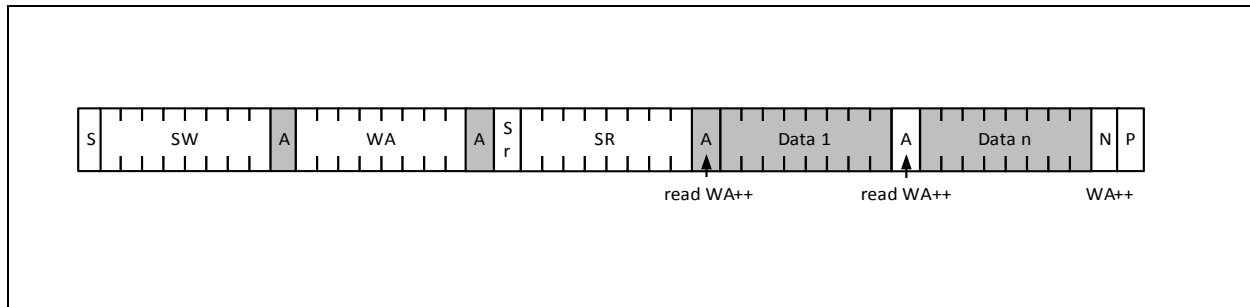

I²C Sequential Read: Shows the format of an I²C sequential read access.

Sequential Read is the extended form of Random Read, as more than one register-data bytes are transferred subsequently. In difference to the Random Read, for a sequential read the transferred register-data bytes are responded by an acknowledgement from the master. The number of data bytes transferred in one sequence is unlimited (consider the behavior of the word-address counter). To terminate the transmission the master has to send a not-acknowledge following the last data byte and generate the STOP condition subsequently.

The AS7211 is compatible to the NXP two wire specifications. http://www.nxp.com/documents/user_manual/UM10204.pdf Version 4.0 Feb 2012 for standard mode and fast mode.

Application Information

Schematics

Figure 27:
Constant Current LED Daylighting with Networking and Spectral Sensing

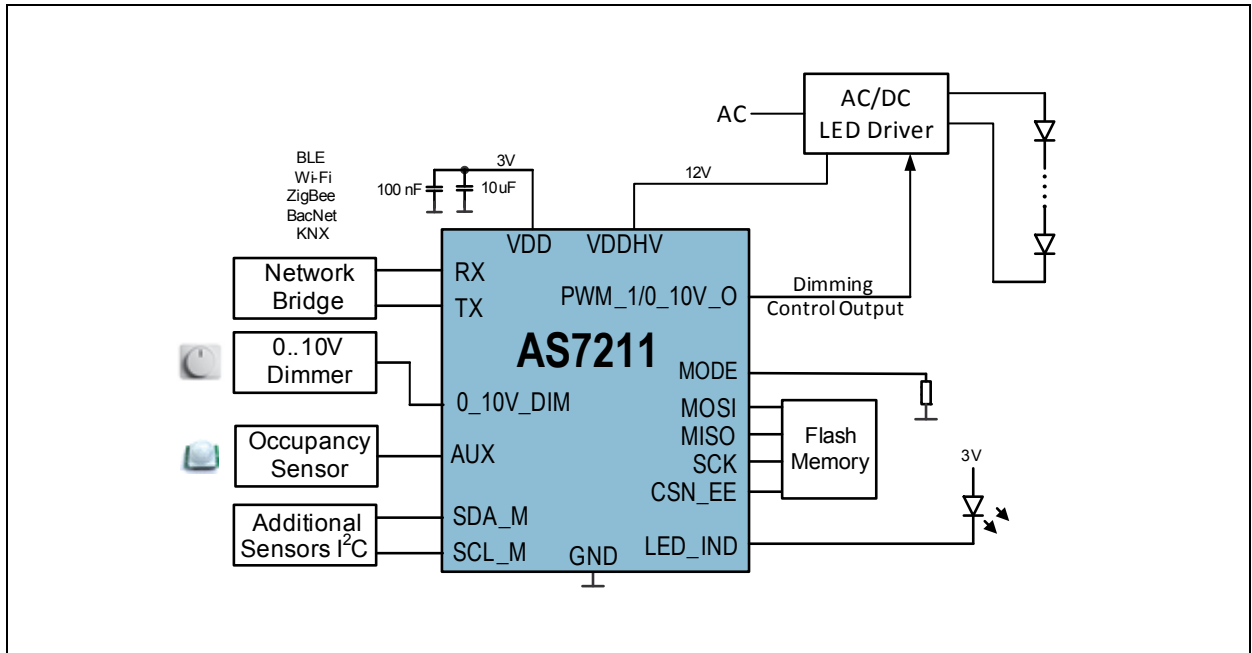

Figure 28:
Constant Voltage LED Daylighting with Networking and Spectral Sensing

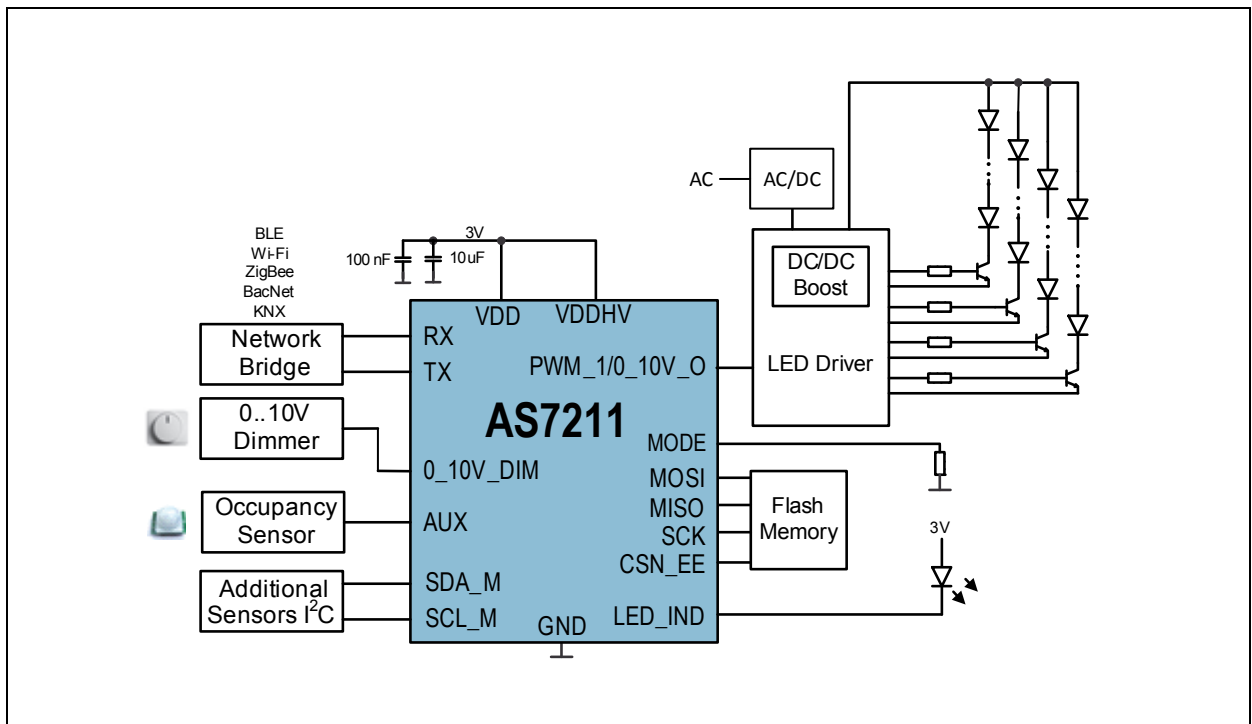
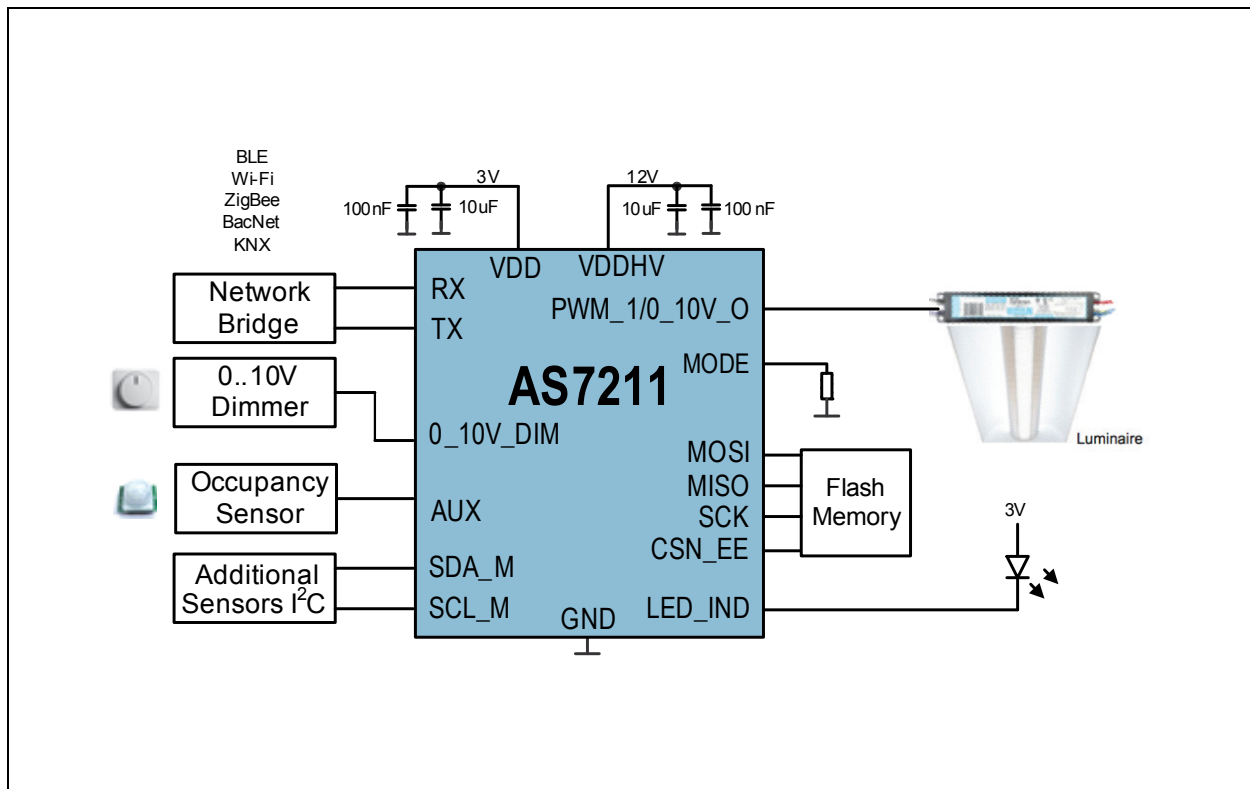
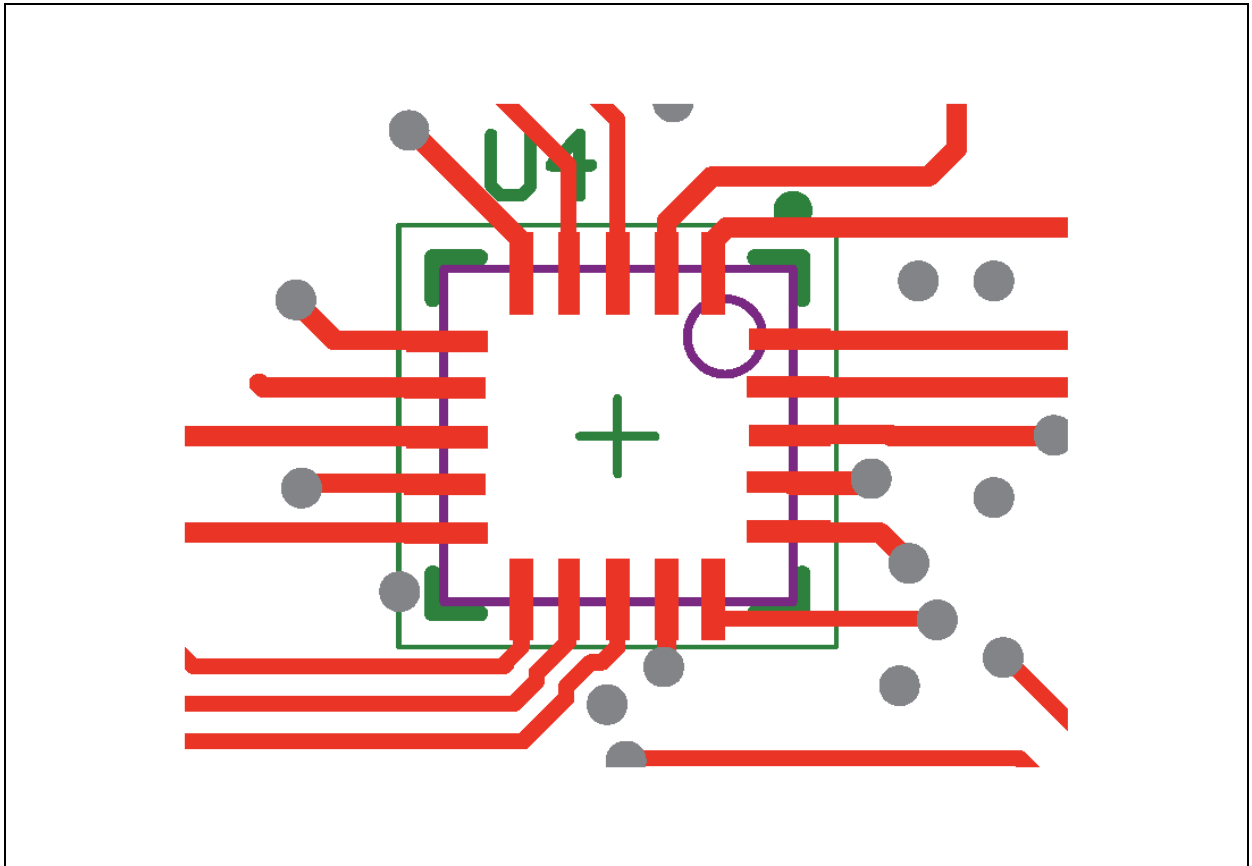

Figure 29:
Fluorescent Daylighting System with Networking and Spectral Sensing



PCB Layout

Figure 30:
Typical Layout Routing



In order to prevent interference, avoid trace routing feedthroughs with exposure directly under the AS7211. An example routing is illustrated in the diagram.

The AS7211 Smart Lighting Integration Kit (SLIK) demo board with schematic and PCB layout documentation is available from **ams** for additional design information.

Package Drawings & Markings

Figure 31:
Package Drawing LGA

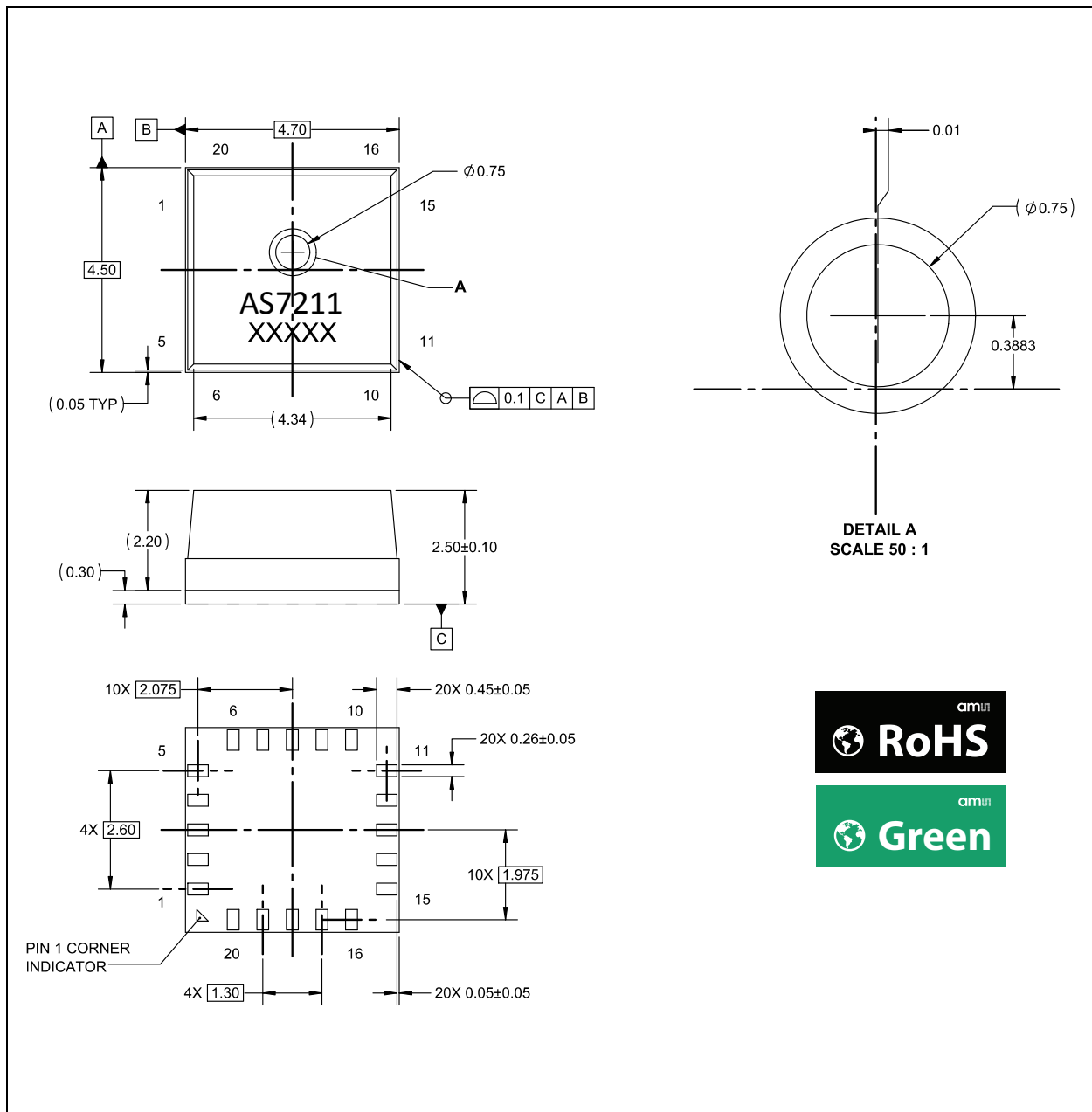

Note(s):

1. Unless otherwise specified, all dimensions are in millimeters.
2. Tolerances: Angular ($\pm .5^\circ$), Two Place Decimal ($\pm .015$), Three Place Decimal ($\pm .010$)
3. Contact finish is Au.
4. This package contains no lead (Pb).
5. This drawing is subject to change without notice.
6. XXXXX = tracecode