



Chipsmall Limited consists of a professional team with an average of over 10 year of expertise in the distribution of electronic components. Based in Hongkong, we have already established firm and mutual-benefit business relationships with customers from,Europe,America and south Asia,supplying obsolete and hard-to-find components to meet their specific needs.

With the principle of "Quality Parts,Customers Priority,Honest Operation,and Considerate Service",our business mainly focus on the distribution of electronic components. Line cards we deal with include Microchip,ALPS,ROHM,Xilinx,Pulse,ON,Everlight and Freescale. Main products comprise IC,Modules,Potentiometer,IC Socket,Relay,Connector.Our parts cover such applications as commercial,industrial, and automotives areas.

We are looking forward to setting up business relationship with you and hope to provide you with the best service and solution. Let us make a better world for our industry!



Contact us

Tel: +86-755-8981 8866 Fax: +86-755-8427 6832

Email & Skype: info@chipsmall.com Web: www.chipsmall.com

Address: A1208, Overseas Decoration Building, #122 Zhenhua RD., Futian, Shenzhen, China



AS7262

6-Channel Visible *Spectral_ID* Device with Electronic Shutter and Smart Interface

General Description

The AS7262 is a cost-effective multi-spectral sensor-on-chip solution designed to address spectral ID applications. This highly integrated device delivers 6-channel multi-spectral sensing in the visible wavelengths from approximately 430nm to 670nm with full-width half-max (FWHM) of 40nm. An integrated LED driver with programmable current is provided for electronic shutter applications.

The AS7262 integrates Gaussian filters into standard CMOS silicon via nano-optic deposited interference filter technology and is packaged in an LGA package that provides a built in aperture to control the light entering the sensor array.

Control and spectral data access is implemented through either the I²C register set, or with a high level AT Spectral Command set via a serial UART.

Ordering Information and Content Guide appear at end of datasheet.

Key Benefits & Features

The benefits and features of AS7262, 6-Channel Visible *Spectral_ID* Device with Electronic Shutter and Smart Interface are listed below:

Figure 1:
Added Value of Using AS7262

Benefits	Features
<ul style="list-style-type: none"> • Compact 6-channel spectrometry solution 	<ul style="list-style-type: none"> • 6 visible channels: 450nm, 500nm, 550nm, 570nm, 600nm and 650nm, each with 40nm FWHM
<ul style="list-style-type: none"> • Simple text-based command interface via UART, or direct register read and write with interrupt on sensor ready option on I²C 	<ul style="list-style-type: none"> • UART or I²C slave digital Interface
<ul style="list-style-type: none"> • Lifetime-calibrated sensing with minimal drift over time or temperature 	<ul style="list-style-type: none"> • Visible filter set realized by silicon interference filters
<ul style="list-style-type: none"> • No additional signal conditioning required 	<ul style="list-style-type: none"> • 16-bit ADC with digital access
<ul style="list-style-type: none"> • Electronic shutter control/synchronization 	<ul style="list-style-type: none"> • Programmable LED drivers
<ul style="list-style-type: none"> • Low voltage operation 	<ul style="list-style-type: none"> • 2.7V to 3.6V with I²C interface
<ul style="list-style-type: none"> • Small, robust package, with built-in aperture 	<ul style="list-style-type: none"> • 20-pin LGA package 4.5mm x 4.7mm x 2.5mm -40°C to 85°C temperature range

Applications

The AS7262 applications include:

- Portable spectrometry
- Horticulture
- Color matching and identification
- Authentication and brand protection
- Precision color tuning/calibration

Block Diagram

The system blocks of this device are shown below.

Figure 2:
AS7262 Visible Spectral_ID System

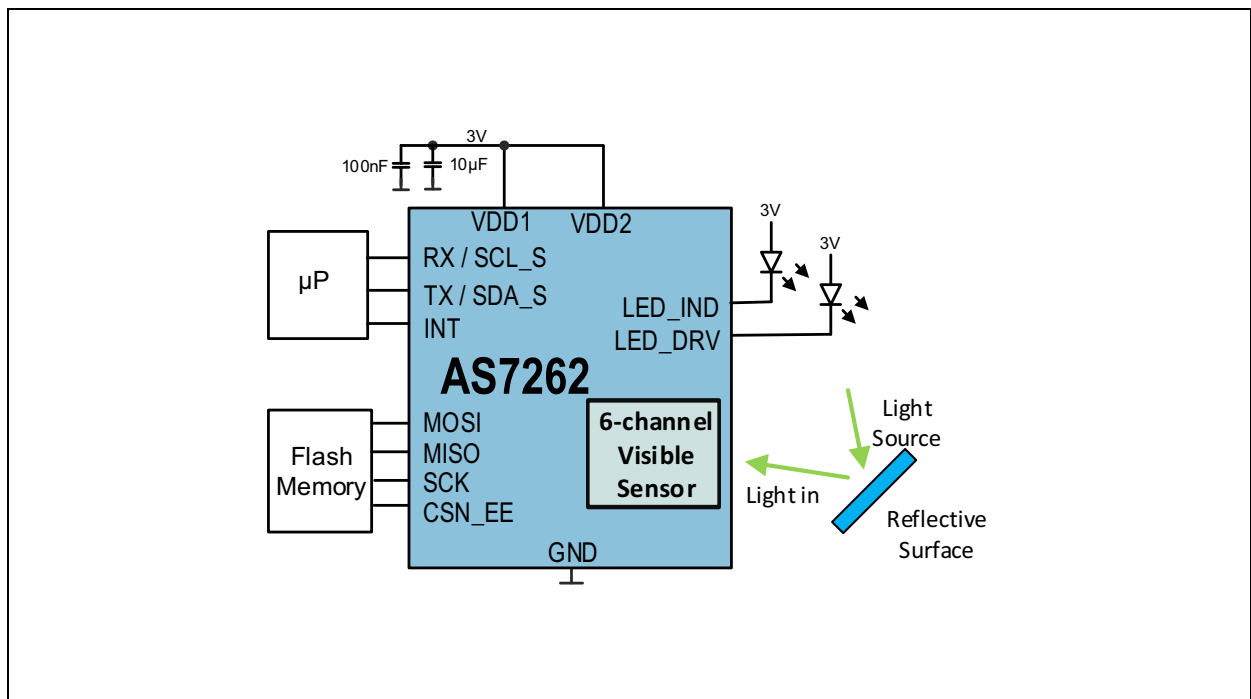

Pin Assignments

The device pin assignments are described below.

Figure 3:
Pin Diagram of AS7262 (Top View)

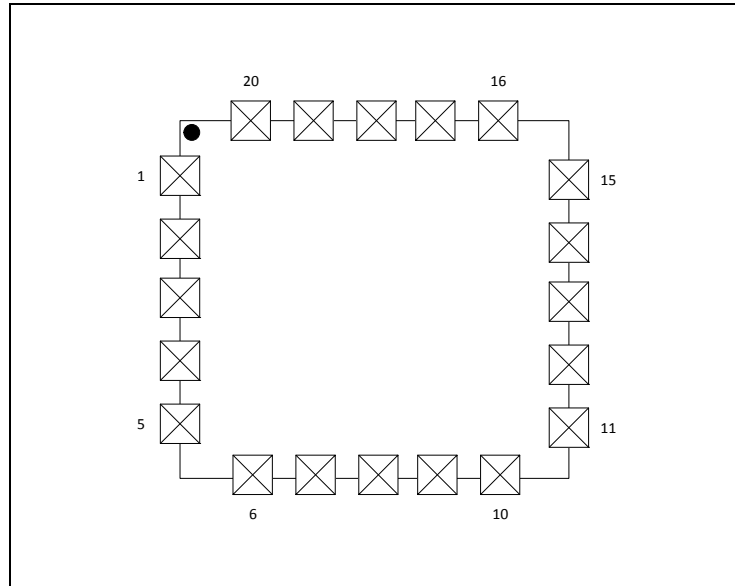

Figure 4:
Pin Description of AS7262

Pin Number	Pin Name	Description
1	NF	Not Functional. Do not connect.
2	RESN	Reset, Active LOW
3	SCK	SPI Serial Clock
4	MOSI	SPI Master Out Slave In
5	MISO	SPI Master In Slave Out
6	CSN_EE	Chip Select for external serial Flash memory, Active LOW
7	CSN_SD	Chip Select for SD Card Interface, Active LOW
8	I ² C_ENB	Select UART (Low) or I ² C (High) Operation
9	NF	Not Functional. Do not connect.
10	NF	Not Functional. Do not connect.
11	RX/SCL_S	RX (UART) or SCL_S (I ² C Slave) Depending on I ² C_ENB
12	TX/SDA_S	TX (UART) or SDA_S (I ² C Slave) Depending on I ² C_ENB
13	INT	Interrupt, Active LOW
14	VDD2	Voltage Supply

Pin Number	Pin Name	Description
15	LED_DRV	LED Driver Output for Driving LED, Current Sink
16	GND	Ground
17	VDD1	Voltage Supply
18	LED_IND	LED Driver Output for Indicator LED, Current Sink
19	NF	Not Functional. Do not connect.
20	NF	Not Functional. Do not connect.

Absolute Maximum Ratings

Stresses beyond those listed under [Absolute Maximum Ratings](#) may cause permanent damage to the device. These are stress ratings only. Functional operation of the device at these or any other conditions beyond those indicated under [Electrical Characteristics](#) is not implied. Exposure to absolute maximum rating conditions for extended periods may affect device reliability.

The device is not designed for high energy UV (ultraviolet) environments, including upward looking outdoor applications, which could affect long term optical performance.

Figure 5:
Absolute Maximum Ratings of AS7262

Symbol	Parameter	Min	Max	Units	Comments
Electrical Parameters					
V _{DD1_MAX}	Supply Voltage VDD1	-0.3	5	V	Pin VDD1 to GND
V _{DD2_MAX}	Supply Voltage VDD2	-0.3	5	V	Pin VDD2 to GND
V _{DD_IO}	Input/Output Pin Voltage	-0.3	VDD+0.3	V	Input/Output Pin to GND
I _{SCR}	Input Current (latch-up immunity)	± 100		mA	JESD78D
Electrostatic Discharge					
ESD _{HBM}	Electrostatic Discharge HBM	± 1000		V	JS-001-2014
ESD _{CDM}	Electrostatic Discharge CDM	± 500		V	JSD22-C101F
Temperature Ranges and Storage Conditions					
T _{STRG}	Storage Temperature Range	-40	85	°C	
T _{BODY}	Package Body Temperature		260	°C	IPC/JEDEC J-STD-020 The reflow peak soldering temperature (body temperature) is specified according to IPC/JEDEC J-STD-020 "Moisture/Reflow Sensitivity Classification for Non-hermetic Solid State Surface Mount Devices."
RH _{NC}	Relative Humidity (non-condensing)	5	85	%	
MSL	Moisture Sensitivity Level	3			Maximum floor life time of 168 hours

Electrical Characteristics

All limits are guaranteed with $V_{DD} = V_{DD1} = V_{DD2} = 3.3V$, $T_{AMB} = 25^{\circ}C$. The parameters with min and max values are guaranteed with production tests or SQC (Statistical Quality Control) methods.

Figure 6:
Electrical Characteristics of AS7262

Symbol	Parameter	Conditions	Min	Typ	Max	Unit
General Operating Conditions						
VDD1 /VDD2	Voltage Operating Supply	UART Interface	2.97	3.3	3.6	V
VDD1 /VDD2	Voltage Operating Supply	I ² C Interface	2.7	3.3	3.6	V
T _{AMB}	Operating Temperature		-40	25	85	°C
I _{VDD}	Operating Current				5	mA
Internal RC Oscillator						
F _{OSC}	Internal RC Oscillator Frequency		15.7	16	16.3	MHz
t _{JITTER} ⁽¹⁾	Internal Clock Jitter	@25°C			1.2	ns
Temperature Sensor						
D _{TEMP}	Absolute Accuracy of the Internal Temperature Measurement		-8.5		8.5	°C
Indicator LED						
I _{IND}	LED Current		1	4	8	mA
I _{ACC}	Accuracy of Current		-30		30	%
V _{LED}	Voltage Range of Connected LED	V _{ds} of current sink	0.3		VDD	V
LED_DRV						
I _{LED1}	LED Current	12.5, 25, 50 or 100	12.5		100	mA
I _{ACC}	Accuracy of Current		-10		10	%
V _{LED}	Voltage Range of Connected LED	V _{ds} of current sink	0.3		VDD	V

Symbol	Parameter	Conditions	Min	Typ	Max	Unit
Digital Inputs and Outputs						
I_{IH}, I_{IL}	Logic Input Current	$V_{in}=0V$ or VDD	-1		1	μA
$I_{IL RESN}$	Logic Input Current (RESN pin)	$V_{in}=0V$	-1		-0.2	mA
V_{IH}	CMOS Logic High Input		$0.7 * V_{DD}$		VDD	V
V_{IL}	CMOS Logic Low Input		0		$0.3 * V_{DD}$	V
V_{OH}	CMOS Logic High Output	$I=1mA$			VDD-0.4	V
V_{OL}	CMOS Logic Low Output	$I=1mA$			0.4	V
$t_{RISE}^{(1)}$	Current Rise Time	C(Pad)=30pF			5	ns
$t_{FALL}^{(1)}$	Current Fall Time	C(Pad)=30pF			5	ns

Note(s):

1. Guaranteed, not tested in production

Timing Characteristics

Figure 7:
AS7262 I²C Slave Timing Characteristics

Symbol	Parameter	Conditions	Min	Typ	Max	Unit
I²C Interface						
f _{SCLK}	SCL Clock Frequency		0		400	kHz
t _{BUF}	Bus Free Time Between a STOP and START		1.3			μs
t _{HS:STA}	Hold Time (Repeated) START		0.6			μs
t _{LOW}	LOW Period of SCL Clock		1.3			μs
t _{HIGH}	HIGH Period of SCL Clock		0.6			μs
t _{SU:STA}	Setup Time for a Repeated START		0.6			μs
t _{HS:DAT}	Data Hold Time		0		0.9	μs
t _{SU:DAT}	Data Setup Time		100			ns
t _R	Rise Time of Both SDA and SCL		20		300	ns
t _F	Fall Time of Both SDA and SCL		20		300	ns
t _{SU:STO}	Setup Time for STOP Condition		0.6			μs
C _B	Capacitive Load for Each Bus Line	CB — total capacitance of one bus line in pF			400	pF
C _{I/O}	I/O Capacitance (SDA, SCL)				10	pF

Figure 8:
I²C Slave Timing Diagram

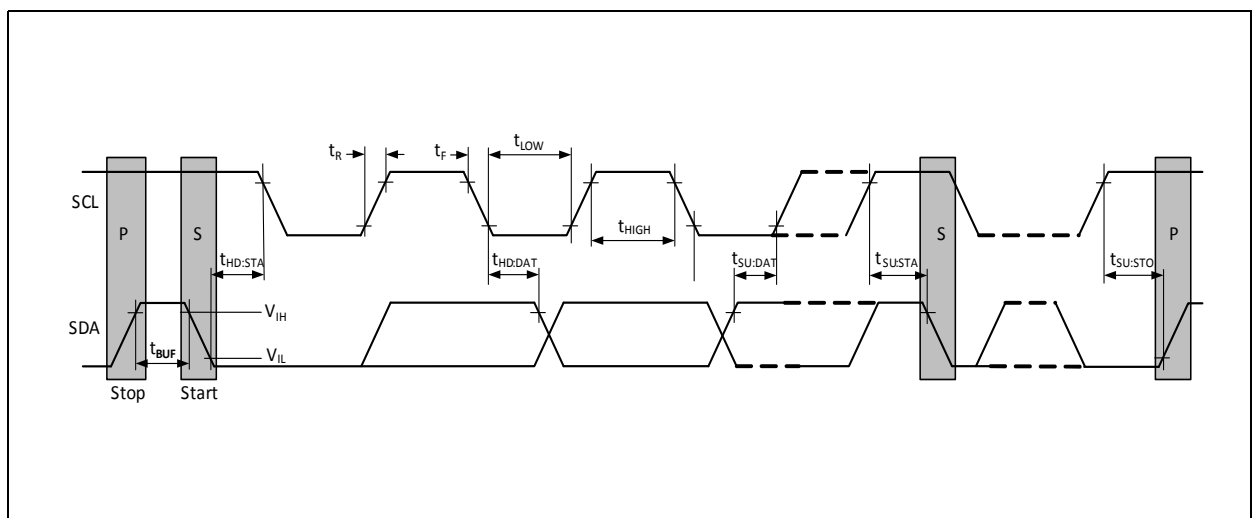

Figure 9:
AS7262 SPI Timing Characteristics

Symbol	Parameter	Conditions	Min	Typ	Max	Unit
SPI Interface						
f_{SCK}	Clock Frequency		0		16	MHz
t_{SCK_H}	Clock High Time		40			ns
t_{SCK_L}	Clock Low Time		40			ns
t_{SCK_RISE}	SCK Rise Time		5			ns
t_{SCK_FALL}	SCK Fall Time		5			ns
t_{CSN_S}	CSN Setup Time	Time between CSN high-low transition to first SCK high transition	50			ns
t_{CSN_H}	CSN Hold Time	Time between last SCK falling edge and CSN low-high transition	100			ns
t_{CSN_DIS}	CSN Disable Time		100			ns
t_{DO_S}	Data-Out Setup Time		5			ns
t_{DO_H}	Data-Out Hold Time		5			ns
t_{DI_V}	Data-In Valid		10			ns

Figure 10:
SPI Master Write Timing Diagram

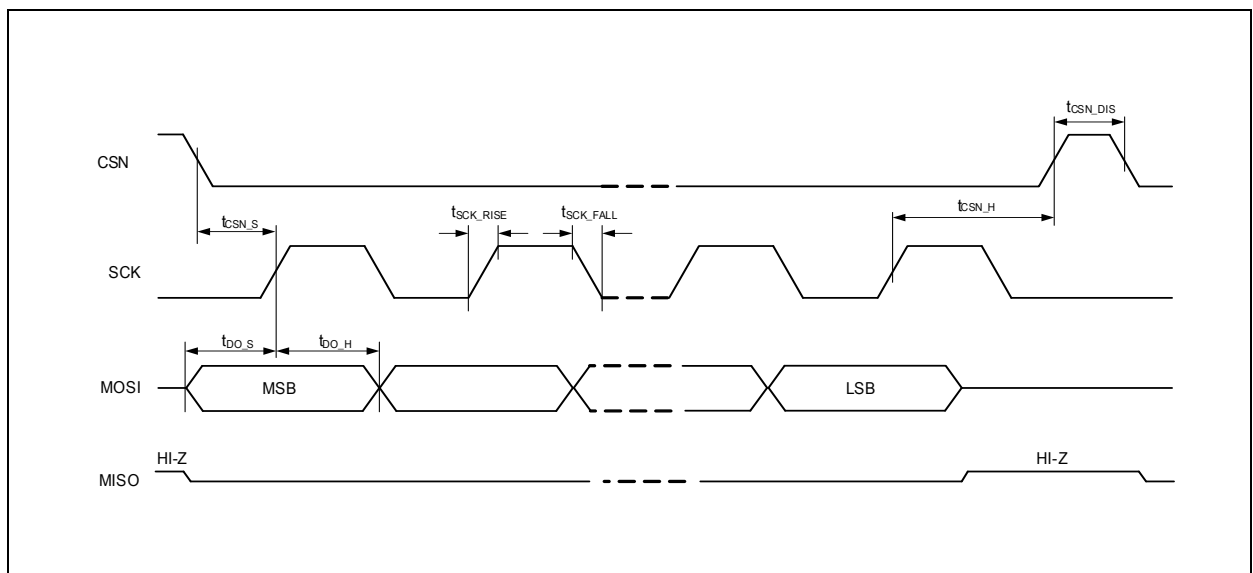
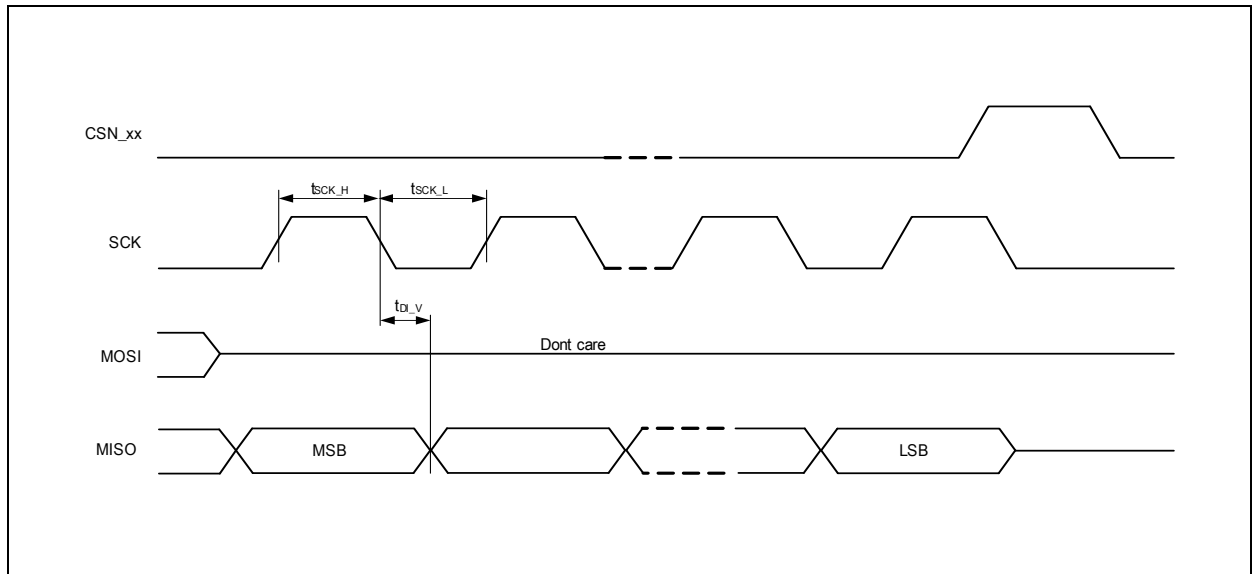

Figure 11:
SPI Master Read Timing Diagram



Optical Characteristics

Figure 12:
Optical Characteristics of AS7262 (Pass Band) ⁽¹⁾

Symbol	Parameter	Test Conditions	Channel (nm)	Min	Typ	Max	Unit
V	Channel V	5700K White LED ^{(2), (4)}	450		45 ^{(3), (4)}		counts/ ($\mu\text{W}/\text{cm}^2$)
B	Channel B	5700K White LED ^{(2), (4)}	500		45 ^{(3), (4)}		counts/ ($\mu\text{W}/\text{cm}^2$)
G	Channel G	5700K White LED ^{(2), (4)}	550		45 ^{(3), (4)}		counts/ ($\mu\text{W}/\text{cm}^2$)
Y	Channel Y	5700K White LED ^{(2), (4)}	570		45 ^{(3), (4)}		counts/ ($\mu\text{W}/\text{cm}^2$)
O	Channel O	5700K White LED ^{(2), (4)}	600		45 ^{(3), (4)}		counts/ ($\mu\text{W}/\text{cm}^2$)
R	Channel R	Incandescent ^{(2), (4)}	650		45 ^{(3), (4)}		counts/ ($\mu\text{W}/\text{cm}^2$)
FWHM	Full Width Half Max		40		40		nm
Wacc	Wavelength Accuracy				± 5		nm
dark	Dark Channel Counts	GAIN=64, $T_{\text{AMB}}=25^\circ\text{C}$				5	counts
PFOV	Package Field of View				± 20.0		deg

Note(s):

1. Calibration and measurements are made using diffused light
2. Each channel is tested with GAIN = 16x, Integration Time (INT_T) = 166ms and VDD = VDD1 = VDD2 = 3.3V, $T_{\text{AMB}}=25^\circ\text{C}$
3. The accuracy of the channel counts/ $\mu\text{W}/\text{cm}^2$ is $\pm 12\%$
4. The light source is either a 5700K white LED with an irradiance of $\sim 600\mu\text{W}/\text{cm}^2$, or an incandescent light with an irradiance of $\sim 1500\mu\text{W}/\text{cm}^2$ (300-1000nm). The energy at each channel (V, B, G, Y, O, R) is calculated with a $\pm 40\text{nm}$ bandwidth around the center wavelengths (450nm, 500nm, 550nm, 570nm, 600nm, 650nm).

Typical Optical Characteristics

Figure 13:
Spectral Responsivity

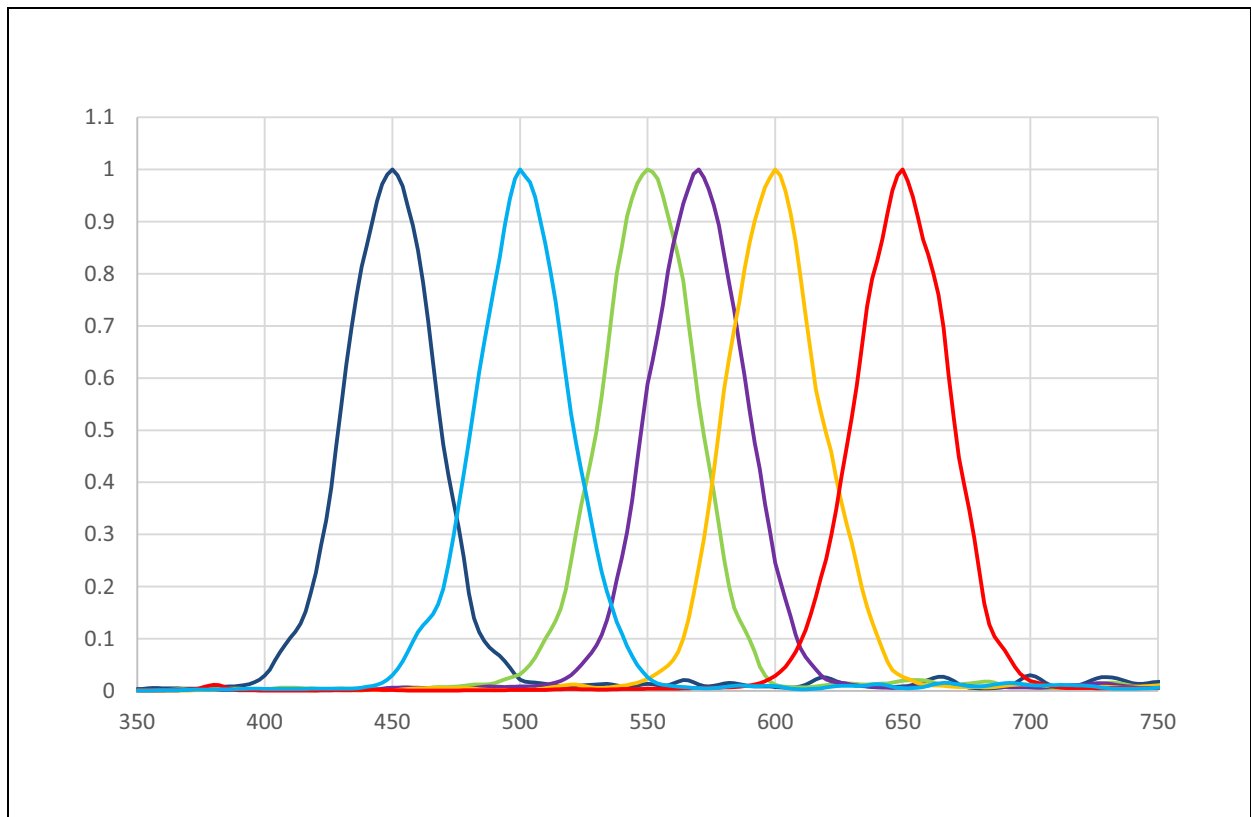

Detailed Description

Figure 14:
AS7262 Functional Block Diagram

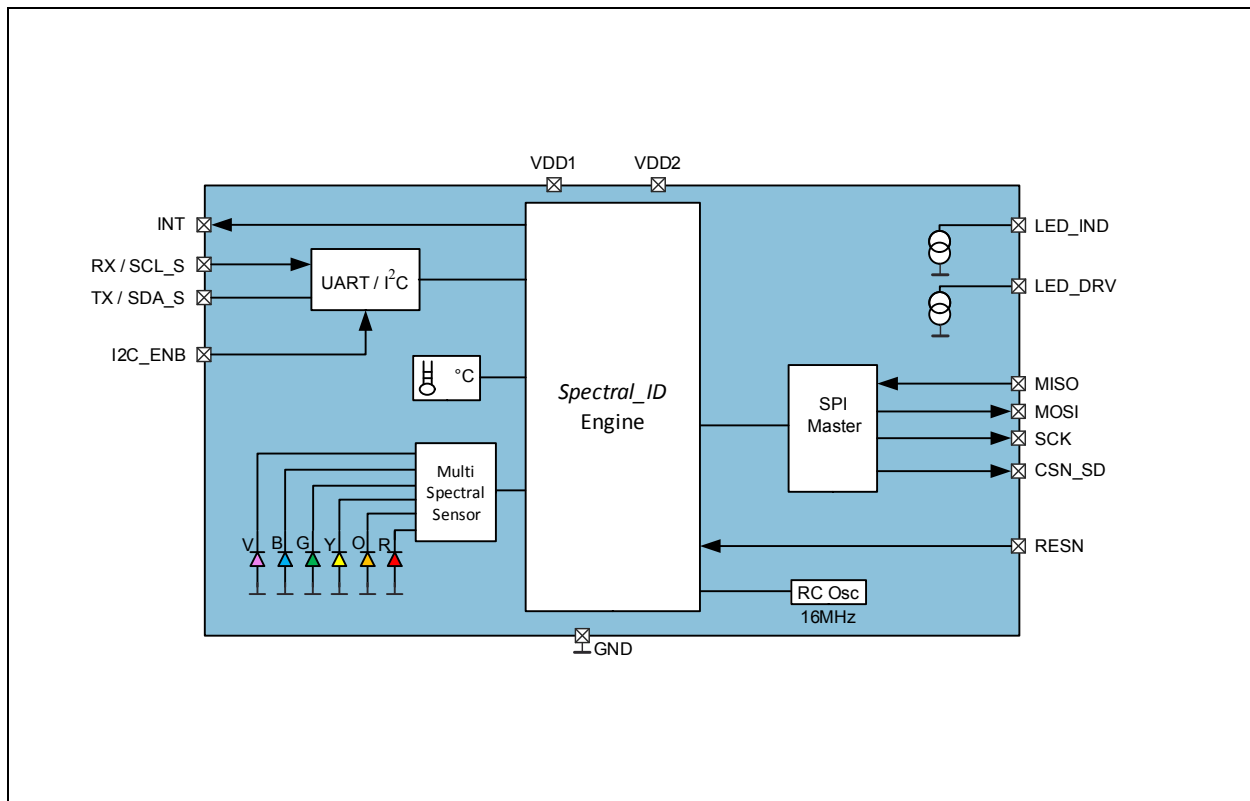

6-Channel Visible *Spectral_ID* Detector

The AS7262 6-channel *Spectral_ID* is a next-generation digital spectral sensor device. Each channel has a Gaussian filter characteristic with a full width half maximum (FWHM) bandwidth of 40nm.

The sensor contains analog-to-digital converters (16-bit resolution ADC), which integrate the current from each channel's photodiode. Upon completion of the conversion cycle, the integrated result is transferred to the corresponding data registers. The transfers are double-buffered to ensure that the integrity of the data is maintained.

Interference filters enable high temperature stability and minimal lifetime drift. Filter accuracy will be affected by the angle of incidence which itself is limited by integrated aperture and internal micro-lens structure. The aperture-limited field of view is $\pm 20.0^\circ$ to deliver specified accuracy.

Data Conversion Description

AS7262 spectral conversion is implemented via two photodiode banks per device. Bank 1 consists of data from the V, G, B, Y photodiodes. Bank 2 consists of data from the G, Y, O, R photodiodes. Spectral conversion requires the integration time (IT in ms) set to complete. If both photodiode banks are required to complete the conversion, the 2nd bank requires an additional IT ms. Minimum IT for a single bank conversion is 2.8 ms. If data is required from all 6 photodiodes then the device must perform 2 full conversions (2 x Integration Time).

The spectral conversion process is controlled with BANK Mode settings as follows:

BANK Mode 0: Data will be available in registers V, B, G & Y (O and R registers will be zero) with conversions occurring continuously.

BANK Mode 1: Data will be available in registers G, Y, O & R (V and B registers will be zero) with conversions occurring continuously.

BANK Mode 2: Data will be available in registers V, B, G, Y, O & R with conversions occurring continuously.

When the bank setting is Mode 0, Mode 1, or Mode 2, the spectral data conversion process operates continuously, with new data available after each IT ms period. In the continuous modes, care should be taken to assure prompt interrupt servicing so that integration values from both banks are all derived from the same spectral conversion cycle.

BANK Mode 3: Data will be available in registers V, B, G, Y, O & R in One-Shot mode

When the bank setting is set to Mode 3 the device initiates One-Shot operation. The DATA_RDY bit is set to 1 once data is available, indicating spectral conversion is complete. One-Shot mode is intended for use when it is critical to ensure spectral conversion results are obtained contemporaneously. An example use for one-shot mode is when a digitally controlled illumination source is briefly turned on for the purpose of taking a set of filter readings.

Figure 15:
Photo Diode Array

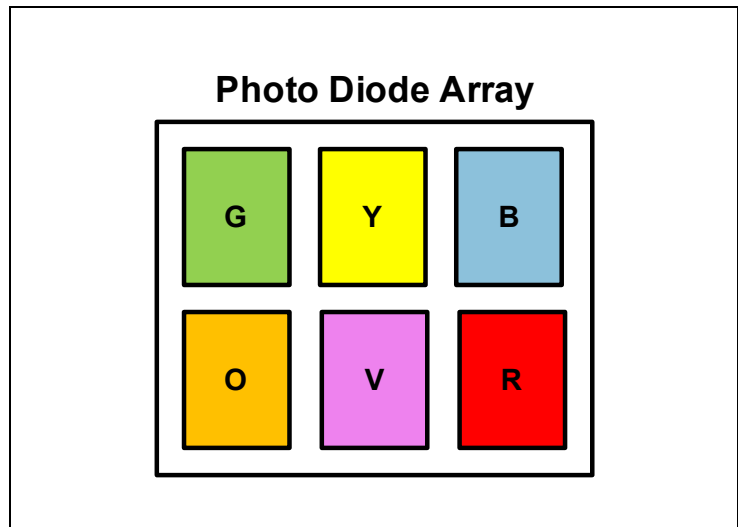
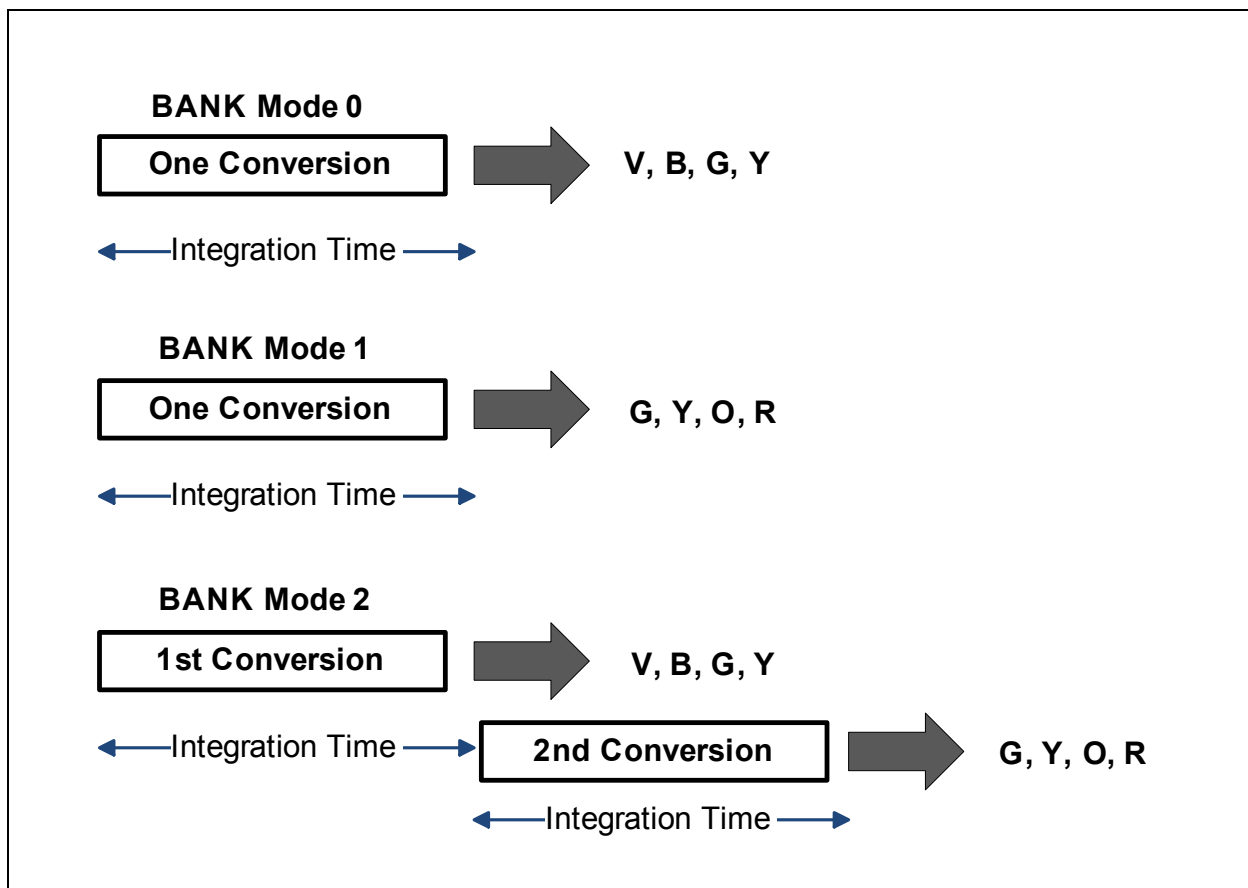

Figure 16:
Bank Mode and Data Conversion



RC Oscillator

The timing generation circuit consists of an on-chip 16MHz, temperature compensated oscillator, which provides the master clock for the AS7262.

Temperature Sensor

The temperature sensor is constantly measuring the on-chip temperature and enables temperature compensation procedures.

Reset

Pulling down the RESN pin for longer than 100ms resets the AS7262.

Figure 17:
Reset Circuit

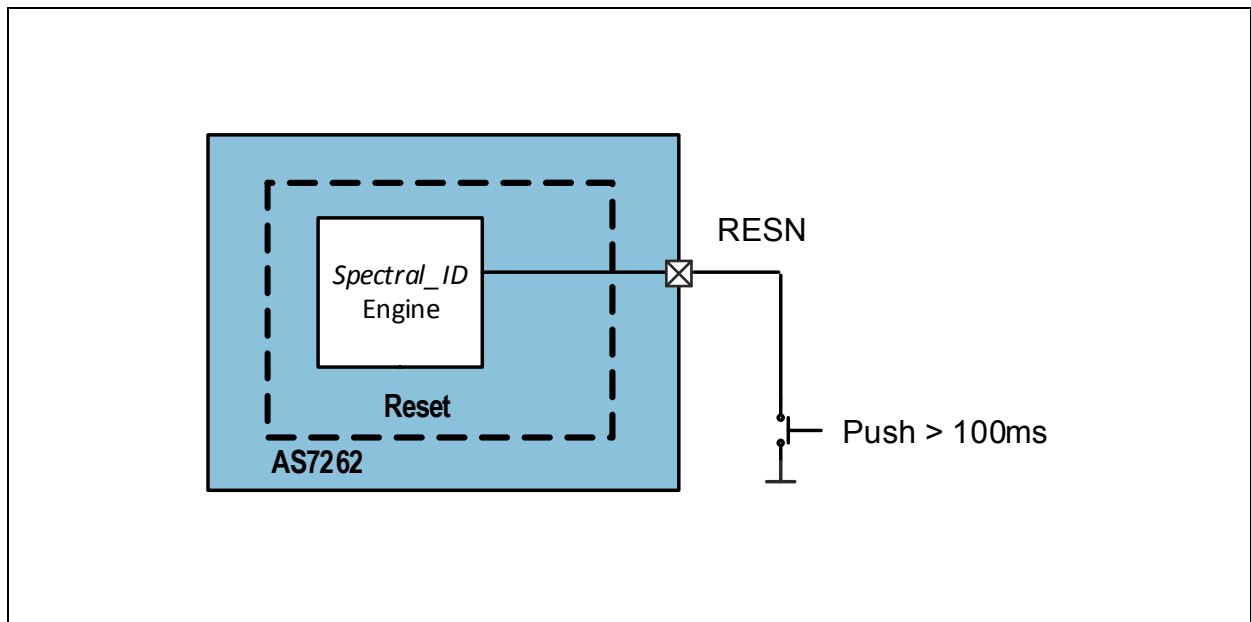

Indicator LED

The LED, connected to pin LED_IND, can be used to indicate programming progress of the device.

While programming the AS7262 via the external SD card the indicator LED starts flashing (500ms pulses). When programming is completed the indicator LED is switched off. The LED (LED0) can be turned ON/OFF via AT commands or via I²C register control. The LED sink current is programmable from 1mA, 2mA, 4mA and 8mA.

Electronic Shutter with LED_DRV Driver Control

There are two LED driver outputs that can be used to control up to 2 LEDs. This will allow different wavelength light sources to be used in the same system. The LED output sink currents are programmable and can drive external LED sources: LED_IND from 1mA, 2mA, 4mA and 8mA and LED_DRV from 12.5mA, 25mA, 50mA and 100mA. The sources can be turned off and on via I²C registers control or AT commands and provides the device with an electronic shutter.

Interrupt Operation

If BANK is set to Mode 0 or Mode 1 then the data is ready after the 1st integration time. If BANK is set to Mode 2 or Mode 3 then the data is ready after two integration times. If the interrupt is enabled (INT = 1) then when the data is ready, the INT line is pulled low and DATA_RDY is set to 1. The INT line is released (returns high) when the control register is read. DATA_RDY is cleared to 0 when any of the sensor registers V, B, G, Y, O & R are read. For multi-byte sensor data (2 or 4 bytes), after the 1st byte is read the remaining get shadow buffer protected in case an integration cycle completes just after the 1st byte is read.

In continuous spectral conversion mode (BANK setting of Mode 0, 1, or 2), the sensors continue to gather information at the rate of the integration time, hence if the sensor registers are not read when the interrupt line goes low, it will stay low and the next cycle's sensor data will be available in the registers at the end of the next integration cycle.

When the control register BANK bits are written with a value of Mode 3, One-Shot Spectral Conversion mode is entered. When a single set of contemporaneous sensor readings is desired, writing BANK Mode 3 to the control register immediately triggers exactly two spectral data conversion cycles. At the end of these two conversion cycles, the DATA_RDY bit is set as for the other BANK modes. To perform a new One-Shot sequence, the control register BANK bits should be written with a value of Mode 3 again. This process may continue until the user writes a different value into the BANK bits.

I²C Slave Interface

If selected by the I²C_ENB pin setting, interface and control can be accomplished through an I²C compatible slave interface to a set of registers that provide access to device control functions and output data. These registers on the AS7262 are, in reality, implemented as *virtual* registers in software. The actual I²C slave hardware registers number only three and are described in the table below. The steps necessary to access the virtual registers defined in the following are explained in pseudocode for external I²C master writes and reads below.

I²C Feature List

- Fast mode (400kHz) and standard mode (100kHz) support.
- 7+1-bit addressing mode.
- Write format: Byte.
- Read format: Byte.
- SDA input delay and SCL spike filtering by integrated RC-components.

Figure 18:
I²C Slave Device Address and Physical Registers

Entity	Description	Note
Device Slave Address	8-bit Slave Address	Byte = 1001001x (device address = 49 hex) x= 1 for Master Read (byte = 93 hex) x= 0 for Master Write (byte = 92 hex)
STATUS Register	I ² C slave interface STATUS register Read-only	Register Address = 0x00 Bit 1: TX_VALID 0 → New data may be written to WRITE register 1 → WRITE register occupied. Do NOT write. Bit 0: RX_VALID 0 → No data is ready to be read in READ register. 1 → Data byte available in READ register.
WRITE Register	I ² C slave interface WRITE register Write-only	Register Address = 0x01 8-Bits of data written by the I ² C Master intended for receipt by the I ² C slave. Used for both <i>virtual</i> register addresses and write data.
READ Register	I ² C slave interface READ register Read-only	Register Address = 0x02 8-Bits of data to be read by the I ² C Master.

I²C Virtual Register Write Access

[I²C Virtual Register Byte Write](#) shows the pseudocode necessary to write virtual registers on the AS7262. Note that, because the actual registers of interest are realized as virtual registers, a means of indicating whether there is a pending read or write operation of a given virtual register is needed. To convey this information, the most significant bit of the virtual register address is used as a marker. If it is 1, then a write is pending, otherwise the slave is expecting a virtual read operation. The pseudocode illustrates the proper technique for polling of the I²C slave status register to ensure the slave is ready for each transaction.

I²C Virtual Register Byte Write

Pseudocode

Poll I²C slave STATUS register;
 If TX_VALID bit is 0, a write can be performed on the interface;
 Send a virtual register address and set the MSB of the register address to 1 to indicate the pending write;
 Poll I²C slave STATUS register;
 If TX_VALID bit is 0, the virtual register address for the write has been received and the data may now be written;
 Write the data.

Sample Code:

```
#define I2C_AS72XX_SLAVE_STATUS_REG 0x00
#define I2C_AS72XX_SLAVE_WRITE_REG 0x01
#define I2C_AS72XX_SLAVE_READ_REG 0x02
#define I2C_AS72XX_SLAVE_TX_VALID 0x02
#define I2C_AS72XX_SLAVE_RX_VALID 0x01

void i2cm_AS72xx_write(uint8_t virtualReg, uint8_t d)
{
    volatile uint8_t status;

    while (1)
    {
        // Read slave I2C status to see if the write buffer is ready.
        status = i2cm_read(I2C_AS72XX_SLAVE_STATUS_REG);

        if ((status & I2C_AS72XX_SLAVE_TX_VALID) == 0)
            // No inbound TX pending at slave. Okay to write now.
            break;
    }

    // Send the virtual register address (setting bit 7 to indicate a pending write).
    i2cm_write(I2C_AS72XX_SLAVE_WRITE_REG, (virtualReg | 0x80));

    while (1)
    {
        // Read the slave I2C status to see if the write buffer is ready.
        status = i2cm_read(I2C_AS72XX_SLAVE_STATUS_REG);

        if ((status & I2C_AS72XX_SLAVE_TX_VALID) == 0)
            // No inbound TX pending at slave. Okay to write data now.
            break;
    }

    // Send the data to complete the operation.
    i2cm_write(I2C_AS72XX_SLAVE_WRITE_REG, d);
}
```

I²C Virtual Register Read Access

I²C Virtual Register Byte Read shows the pseudocode necessary to read virtual registers on the AS7262. Note that in this case, reading a virtual register, the register address is not modified.

I²C Virtual Register Byte Read

Pseudocode

```

Poll I2C slave STATUS register;
If TX_VALID bit is 0, the virtual register address for the read may be written;
Send a virtual register address;
Poll I2C slave STATUS register;
If RX_VALID bit is 1, the read data is ready;
Read the data.
    
```

Sample Code:

```

uint8_t i2cm_AS72xx_read(uint8_t virtualReg)
{
    volatile uint8_t status, d;

    while (1)
    {
        // Read slave I2C status to see if the read buffer is ready.
        status = i2cm_read(I2C_AS72XX_SLAVE_STATUS_REG);

        if ((status & I2C_AS72XX_SLAVE_TX_VALID) == 0)
            // No inbound TX pending at slave. Okay to write now.
            break;
    }
    // Send the virtual register address (setting bit 7 to indicate a pending write).
    i2cm_write(I2C_AS72XX_SLAVE_WRITE_REG, virtualReg);

    while (1)
    {
        // Read the slave I2C status to see if our read data is available.
        status = i2cm_read(I2C_AS72XX_SLAVE_STATUS_REG);

        if ((status & I2C_AS72XX_SLAVE_RX_VALID) != 0)
            // Read data is ready.
            break;
    }
    // Read the data to complete the operation.
    d = i2cm_read(I2C_AS72XX_SLAVE_READ_REG);
    return d; s
}
    
```

The details of the `i2cm_read()` and `i2cm_write()` functions in previous Figures are dependent upon the nature and implementation of the external I²C master device.

4-Byte Floating-Point (FP) Registers

Several 4-byte registers (hex) are used by the AS7262. Here is an example of how these registers are used to represent floating point data (based on the IEEE 754 standard):

Figure 19:
Example of the IEEE 754 Standard

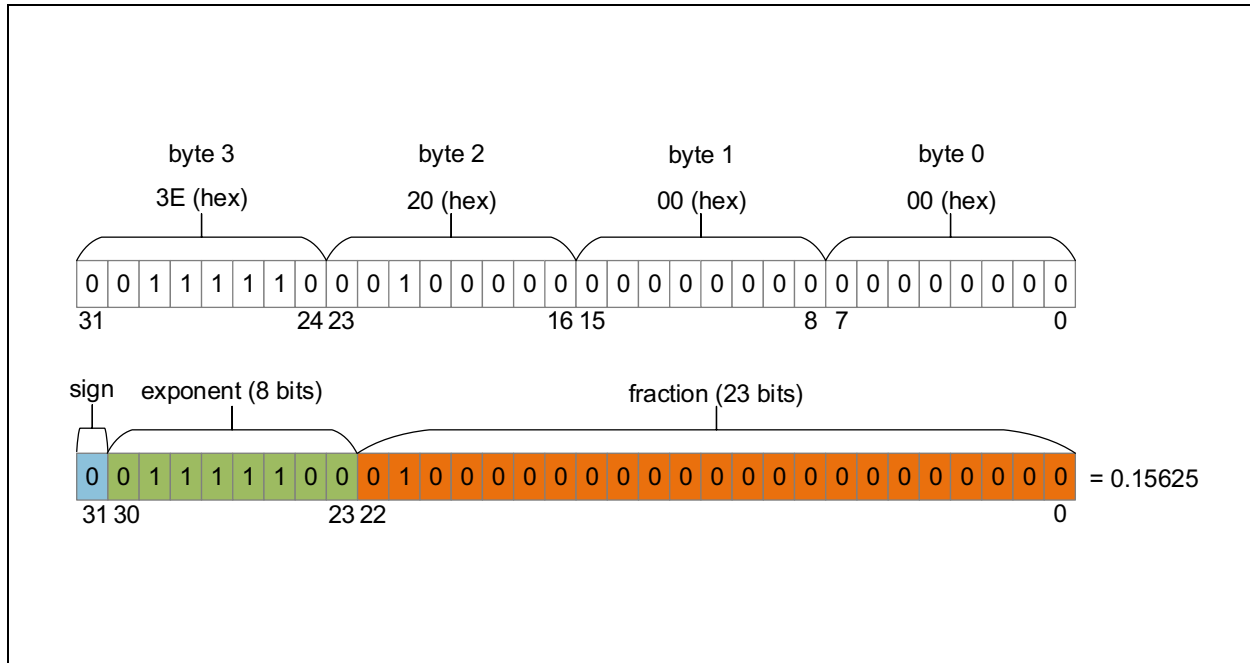

The floating point (FP) value assumed by 32 **bit binary32 data** with a biased exponent **e** (the 8 bit unsigned integer) and a **23 bit fraction** is (for the above example):

$$FP \text{ value} = (-1)^{\text{sign}} \cdot \left(1 + \sum_{i=1}^{23} b_{23-i} 2^{-i} \right) \times 2^{(e-127)}$$

$$FP \text{ value} = (-1)^0 \cdot \left(1 + \sum_{i=1}^{23} b_{23-i} 2^{-i} \right) \times 2^{(124-127)}$$

$$FP \text{ value} = 1 \times (1 + 2^{-2}) \times 2^{-3} = 0.15625$$

I²C Virtual Register Set

Figure 20 provides a summary of the AS7262 I²C register set. Figures after that provide additional register details. All register data is hex, and all multi-byte entities are Big Endian (most significant byte is situated at the lowest register address).

Multiple byte registers (2 byte integer, or, 4 byte floating point) must be read in the order of ascending register addresses (low to high). And if capable of being written to, must also be written in the order of ascending register addresses.

Figure 20:
I²C Virtual Register Set Overview

Addr	Name	<D7>	<D6>	<D5>	<D4>	<D3>	<D2>	<D1>	<D0>
Version Registers									
0x00:0x01	HW_Version	Hardware Version							
0x02:0x03	FW_Version	Firmware Version							
Control Registers									
0x04	Control_Setup	RST	INT	GAIN		Bank		DATA_RDY	RSVD
0x05	INT_T	Integration Time							
0x06	Device_Temp	Device Temperature							
0x07	LED_Control	RSVD		ICL_DRV	LED_DRV	ICL_IND		LED_IND	
Sensor Raw Data Registers									
0x08	V_High	Channel V High Data Byte							
0x09	V_Low	Channel V Low Data Byte							
0x0A	B_High	Channel B High Data Byte							
0x0B	B_Low	Channel B Low Data Byte							
0x0C	G_High	Channel G High Data Byte							
0x0D	G_Low	Channel G Low Data Byte							
0x0E	Y_High	Channel Y High Data Byte							
0x0F	Y_Low	Channel Y Low Data Byte							
0x10	O_High	Channel O High Data Byte							
0x11	O_Low	Channel O Low Data Byte							
0x12	R_High	Channel R High Data Byte							
0x13	R_Low	Channel R Low Data Byte							

Addr	Name	<D7>	<D6>	<D5>	<D4>	<D3>	<D2>	<D1>	<D0>
Sensor Calibrated Data Registers									
0x14:0x17	V_Cal	Channel V Calibrated Data (floating point)							
0x18:0x1B	B_Cal	Channel B Calibrated Data (floating point)							
0x1C:0x1F	G_Cal	Channel G Calibrated Data (floating point)							
0x20:0x23	Y_Cal	Channel Y Calibrated Data (floating point)							
0x24:0x27	O_Cal	Channel O Calibrated Data (floating point)							
0x28:0x2B	R_Cal	Channel R Calibrated Data (floating point)							

Detailed Register Description

Figure 21:
HW Version Registers

Addr: 0x00		HW_Version		
Bit	Bit Name	Default	Access	Bit Description
7:0	Device Type	01000000	R	Device type number
Addr: 0x01		HW_Version		
Bit	Bit Name	Default	Access	Bit Description
7:0	HW Version	00111110	R	Hardware version

Figure 22:
FW Version Registers

Addr: 0x02		FW_Version		
Bit	Bit Name	Default	Access	Bit Description
7:6	Minor Version		R	Minor version [1:0]
5:0	Sub Version		R	Sub version
Addr: 0x03		FW_Version		
Bit	Bit Name	Default	Access	Bit Description
7:4	Major version		R	Major version
3:0	Minor version		R	Minor version [5:2]

Figure 23:
Control Setup Register

Addr: 0x04/0x84		Control_Setup		
Bit	Bit Name	Default	Access	Bit Description
7	RST	0	R/W	Soft Reset, Set to 1 for soft reset, goes to 0 automatically after the reset
6	INT	0	R/W	Enable interrupt pin output (INT), 1: Enable, 0: Disable
5:4	GAIN	0	R/W	Sensor Channel Gain Setting (all channels) 'b00=1x; 'b01=3.7x; 'b10=16x; 'b11=64x
3:2	BANK	10	R/W	Data Conversion Type (continuous) 'b00=Mode 0; 'b01=Mode 1; 'b10=Mode 2; 'b11=Mode 3 One-Shot
1	DATA_RDY	0	R/W	1: Data Ready to Read, sets INT active if interrupt is enabled. Can be polled if not using INT.
0	RSVD	0	R	Reserved; Unused

Figure 24:
Integration Time Register

Addr: 0x05/0x85		INT_T		
Bit	Bit Name	Default	Access	Bit Description
7:0	INT_T	0xFF	R/W	Integration time = <value> * 2.8ms

Figure 25:
Device Temperature Register

Addr: 0x06		Device_Temp		
Bit	Bit Name	Default	Access	Bit Description
7:0	Device_Temp		R	Device temperature data byte (°C)