



Chipsmall Limited consists of a professional team with an average of over 10 year of expertise in the distribution of electronic components. Based in Hongkong, we have already established firm and mutual-benefit business relationships with customers from,Europe,America and south Asia,supplying obsolete and hard-to-find components to meet their specific needs.

With the principle of "Quality Parts,Customers Priority,Honest Operation,and Considerate Service",our business mainly focus on the distribution of electronic components. Line cards we deal with include Microchip,ALPS,ROHM,Xilinx,Pulse,ON,Everlight and Freescale. Main products comprise IC,Modules,Potentiometer,IC Socket,Relay,Connector.Our parts cover such applications as commercial,industrial, and automotives areas.

We are looking forward to setting up business relationship with you and hope to provide you with the best service and solution. Let us make a better world for our industry!



Contact us

Tel: +86-755-8981 8866 Fax: +86-755-8427 6832

Email & Skype: info@chipsmall.com Web: www.chipsmall.com

Address: A1208, Overseas Decoration Building, #122 Zhenhua RD., Futian, Shenzhen, China





5 V 64K X 16 CMOS SRAM

Features

- Industrial and commercial versions
- Organization: 65,536 words × 16 bits
- Center power and ground pins for low noise
- High speed
 - 10/12/15/20 ns address access time
 - 5, 6, 7, 8 ns output enable access time
- Low power consumption: ACTIVE
 - 605 mW / max @ 10 ns
- Low power consumption: STANDBY
 - 55 mW / max CMOS I/O
- 6 T 0.18 u CMOS technology
- Easy memory expansion with \overline{CE} , \overline{OE} inputs

- TTL-compatible, three-state I/O
- JEDEC standard packaging
 - 44-pin 400 mil SOJ
 - 44-pin TSOP 2-400
- ESD protection ≥ 2000 volts
- Latch-up current ≥ 200 mA

Pin arrangement

44-Pin SOJ (400 mil), TSOP 2

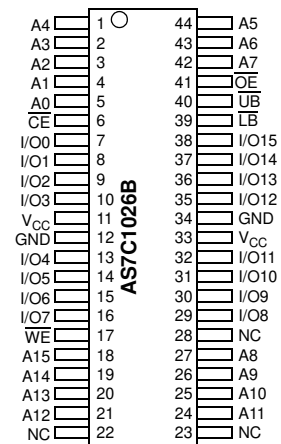

Logic block diagram

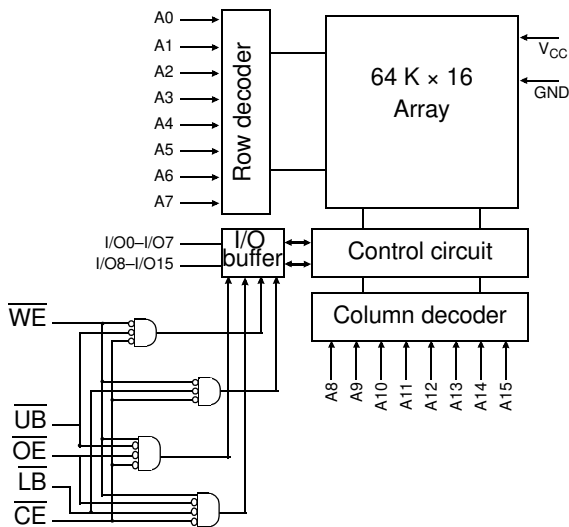

Selection guide

	-10	-12	-15	-20	Unit
Maximum address access time	10	12	15	20	ns
Maximum output enable access time	5	6	7	8	ns
Maximum operating current	110	100	90	80	mA
Maximum CMOS standby current	10	10	10	10	mA



Functional description

The AS7C1026B is a high-performance CMOS 1,048,576-bit Static Random Access Memory (SRAM) device organized as 65,536 words \times 16 bits. It is designed for memory applications where fast data access, low power, and simple interfacing are desired.

Equal address access and cycle times (t_{AA} , t_{RC} , t_{WC}) of 10/12/15/20 ns with output enable access times (t_{OE}) of 5, 6, 7, 8 ns are ideal for high-performance applications.

When \overline{CE} is high, the device enters standby mode. If inputs are still toggling, the device will consume I_{SB} power. If the bus is static, then full standby power is reached (I_{SB1}). For example, the AS7C1026B is guaranteed not to exceed 55 mW under nominal full standby conditions.

A write cycle is accomplished by asserting write enable (\overline{WE}) and chip enable (\overline{CE}). Data on the input pins I/O0 through I/O15 is written on the rising edge of \overline{WE} (write cycle 1) or \overline{CE} (write cycle 2). To avoid bus contention, external devices should drive I/O pins only after outputs have been disabled with output enable (\overline{OE}) or write enable (\overline{WE}).

A read cycle is accomplished by asserting output enable (\overline{OE}) and chip enable (\overline{CE}) with write enable (\overline{WE}) high. The chip drives I/O pins with the data word referenced by the input address. When either chip enable or output enable is inactive or write enable is active, output drivers stay in high-impedance mode.

The device provides multiple center power and ground pins, and separate byte enable controls, allowing individual bytes to be written and read. \overline{LB} controls the lower bits, I/O0 through I/O7, and \overline{UB} controls the higher bits, I/O8 through I/O15.

All chip inputs and outputs are TTL-compatible, and operation is from a single 5 V supply. The device is packaged in common industry standard packages.

Absolute maximum ratings

Parameter	Symbol	Min	Max	Unit
Voltage on V_{CC} relative to GND	V_{t1}	-0.50	+7.0	V
Voltage on any pin relative to GND	V_{t2}	-0.50	$V_{CC} + 0.50$	V
Power dissipation	P_D	-	1.0	W
Storage temperature (plastic)	T_{stg}	-65	+150	$^{\circ}C$
Ambient temperature with VCC applied	T_{bias}	-55	+125	$^{\circ}C$
DC current into outputs (low)	I_{OUT}	-	20	mA

Note: Stresses greater than those listed under Absolute Maximum Ratings may cause permanent damage to the device. This is a stress rating only and functional operation of the device at these or any other conditions outside those indicated in the operational sections of this specification is not implied. Exposure to absolute maximum rating conditions for extended periods may affect reliability.

Truth table

\overline{CE}	\overline{WE}	\overline{OE}	\overline{LB}	\overline{UB}	I/O0–I/O7	I/O8–I/O15	Mode
H	X	X	X	X	High Z	High Z	Standby (I_{SB} , I_{SB1})
L	H	L	L	H	D_{OUT}	High Z	Read I/O0–I/O7 (I_{CC})
L	H	L	H	L	High Z	D_{OUT}	Read I/O8–I/O15 (I_{CC})
L	H	L	L	L	D_{OUT}	D_{OUT}	Read I/O0–I/O15 (I_{CC})
L	L	X	L	L	D_{IN}	D_{IN}	Write I/O0–I/O15 (I_{CC})
L	L	X	L	H	D_{IN}	High Z	Write I/O0–I/O7 (I_{CC})
L	L	X	H	L	High Z	D_{IN}	Write I/O8–I/O15 (I_{CC})
L	H	H	X	X	High Z	High Z	Output disable (I_{CC})
L	X	X	H	H	High Z	High Z	Output disable (I_{CC})

Key: H = high, L = low, X = don't care.



Recommended operating conditions

Parameter	Symbol	Min	Nominal	Max	Unit	
Supply voltage	V_{CC}	4.5	5.0	5.5	V	
Input voltage	V_{IH}	2.2	–	$V_{CC} + 0.5$	V	
	V_{IL}	-0.5	–	0.8	V	
Ambient operating temperature	commercial	T_A	0	–	70	°C
	industrial	T_A	-40	–	85	°C

V_{IL} min = -1.0V for pulse width less than 5ns

V_{IH} max = $V_{CC} + 2.0V$ for pulse width less than 5ns.

DC operating characteristics (over the operating range)¹

Parameter	Sym	Test conditions	-10		-12		-15		-20		Unit
			Min	Max	Min	Max	Min	Max	Min	Max	
Input leakage current	$ I_{LI} $	$V_{CC} = \text{Max},$ $V_{IN} = \text{GND to } V_{CC}$	–	1	–	1	–	1	–	1	μA
Output leakage current	$ I_{LO} $	$V_{CC} = \text{Max}, \overline{CE} = V_{IH},$ $V_{OUT} = \text{GND to } V_{CC}$	–	1	–	1	–	1	–	1	μA
Operating power supply current	I_{CC}	$V_{CC} = \text{Max},$ $\overline{CE} \leq V_{IL}, I_{OUT} = 0\text{mA},$ $f = f_{\text{Max}}$	–	110	–	100	–	90	–	80	mA
Standby power supply current	I_{SB}	$V_{CC} = \text{Max},$ $\overline{CE} \geq V_{IH}, f = f_{\text{Max}}$	–	50	–	45	–	45	–	40	mA
	I_{SB1}	$V_{CC} = \text{Max}, \overline{CE} \geq V_{CC} - 0.2\text{ V},$ $V_{IN} \leq 0.2\text{ V}$ or $V_{IN} \geq V_{CC} - 0.2\text{ V}, f = 0$	–	10	–	10	–	10	–	10	mA
Output voltage	V_{OL}	$I_{OL} = 8\text{ mA}, V_{CC} = \text{Min}$	–	0.4	–	0.4	–	0.4	–	0.4	V
	V_{OH}	$I_{OH} = -4\text{ mA}, V_{CC} = \text{Min}$	2.4	–	2.4	–	2.4	–	2.4	–	V

Capacitance ($f = 1\text{MHz}, T_a = 25\text{ °C}, V_{CC} = \text{NOMINAL}$)²

Parameter	Symbol	Signals	Test conditions	Max	Unit
Input capacitance	C_{IN}	A, \overline{CE} , \overline{WE} , \overline{OE} , \overline{LB} , \overline{UB}	$V_{IN} = 0\text{ V}$	5	pF
I/O capacitance	$C_{I/O}$	I/O	$V_{IN} = V_{OUT} = 0\text{ V}$	7	pF



Read cycle (over the operating range)^{3,9}

Parameter	Symbol	-10		-12		-15		-20		Unit	Notes
		Min	Max	Min	Max	Min	Max	Min	Max		
Read cycle time	t_{RC}	10	-	12	-	15	-	20	-	ns	
Address access time	t_{AA}	-	10	-	12	-	15	-	20	ns	3
Chip enable (\overline{CE}) access time	t_{ACE}	-	10	-	12	-	15	-	20	ns	3
Output enable (\overline{OE}) access time	t_{OE}	-	5	-	6	-	7	-	8	ns	
Output hold from address change	t_{OH}	3	-	3	-	3	-	3	-	ns	5
\overline{CE} low to output in low Z	t_{CLZ}	3	-	3	-	3	-	3	-	ns	4, 5
\overline{CE} high to output in high Z	t_{CHZ}	-	4	-	5	-	6	-	7	ns	4, 5
\overline{OE} low to output in low Z	t_{OLZ}	0	-	0	-	0	-	0	-	ns	4, 5
Byte select access time	t_{BA}	-	5	-	6	-	7	-	8	ns	
Byte select Low to low Z	t_{BLZ}	0	-	0	-	0	-	0	-	ns	4, 5
Byte select High to high Z	t_{BHZ}	-	5	-	6	-	6	-	7	ns	4, 5
\overline{OE} high to output in high Z	t_{OHZ}	-	4	-	5	-	6	-	7	ns	4, 5
Power up time	t_{PU}	0	-	0	-	0	-	0	-	ns	4, 5
Power down time	t_{PD}	-	10	-	12	-	15	-	20	ns	4, 5

Key to switching waveforms

Rising input

Falling input

Undefined output/don't care

Read waveform 1 (address controlled)^{3,6,7,9}

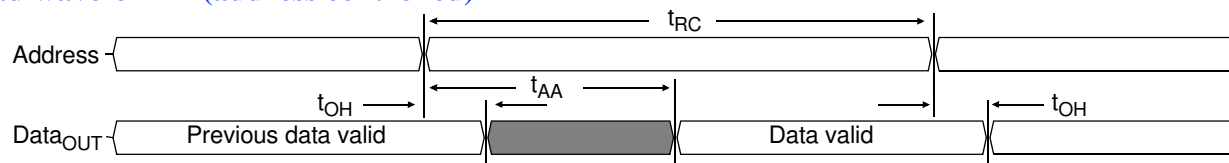



Read waveform 2 (\overline{OE} , \overline{CE} , \overline{UB} , \overline{LB} controlled)^{3,6,8,9}

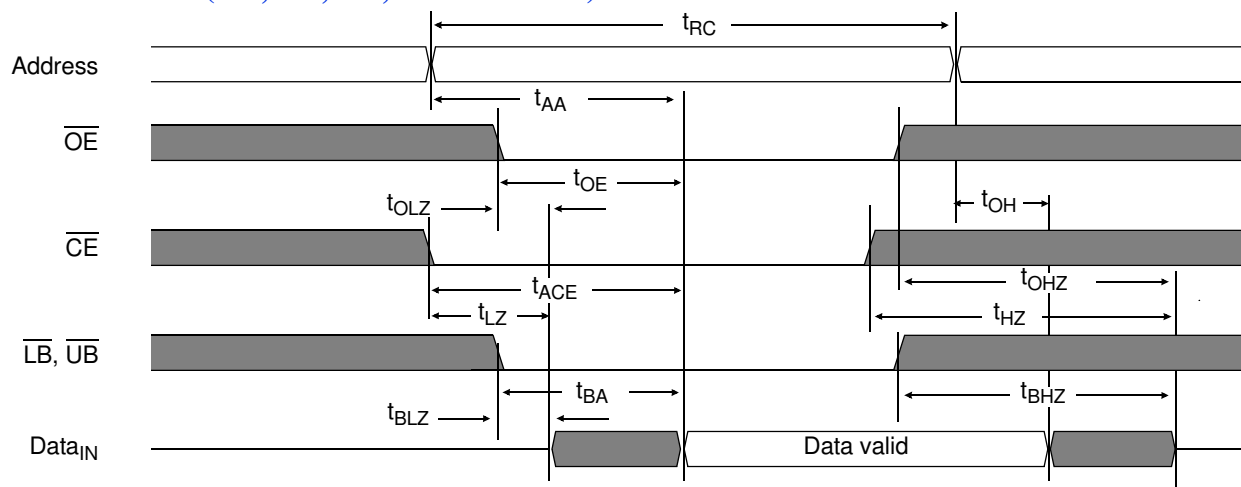

Write cycle (over the operating range) ¹¹

Parameter	Symbol	-10		-12		-15		-20		Unit	Notes
		Min	Max	Min	Max	Min	Max	Min	Max		
Write cycle time	t_{WC}	10	–	12	–	15	–	20	–	ns	
Chip enable (\overline{CE}) to write end	t_{CW}	8	–	9	–	10	–	12	–	ns	
Address setup to write end	t_{AW}	8	–	9	–	10	–	12	–	ns	
Address setup time	t_{AS}	0	–	0	–	0	–	0	–	ns	
Write pulse width	t_{WP}	7	–	8	–	9	–	12	–	ns	
Write recovery time	t_{WR}	0	–	0	–	0	–	0	–	ns	
Address hold from end of write	t_{AH}	0	–	0	–	0	–	0	–	ns	
Data valid to write end	t_{DW}	5	–	6	–	8	–	10	–	ns	
Data hold time	t_{DH}	0	–	0	–	0	–	0	–	ns	5
Write enable to output in high Z	t_{WZ}	–	5	–	6	–	7	–	8	ns	4, 5
Output active from write end	t_{OW}	1	–	1	–	1	–	2	–	ns	4, 5
Byte select low to end of write	t_{BW}	7	–	8	–	9	–	9	–	ns	



Write waveform 1 ($\overline{\text{WE}}$ controlled)¹¹

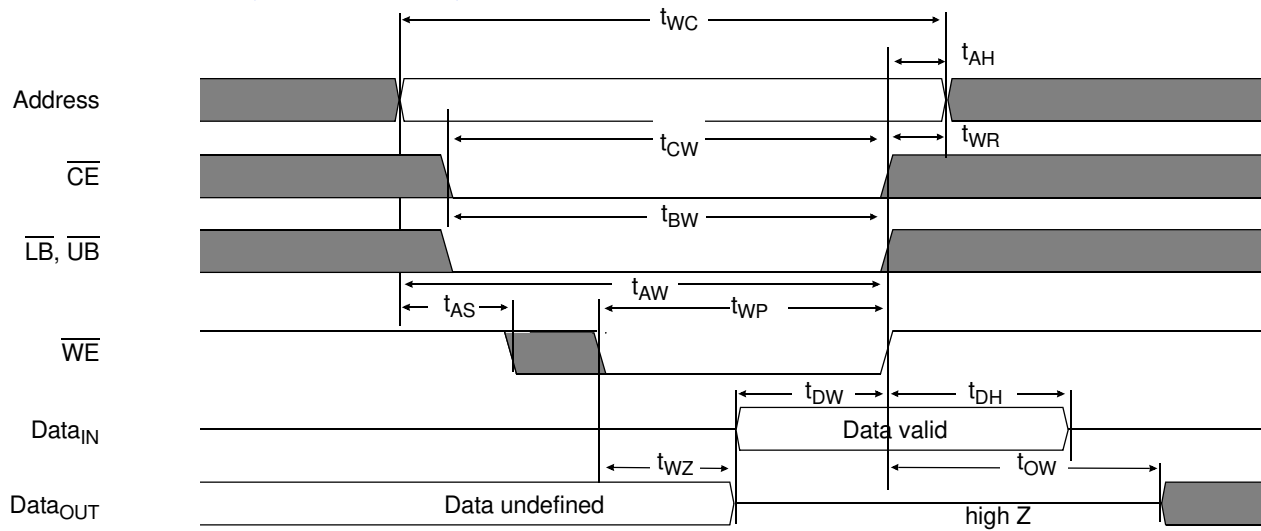

Write waveform 2 ($\overline{\text{CE}}$ controlled)¹¹

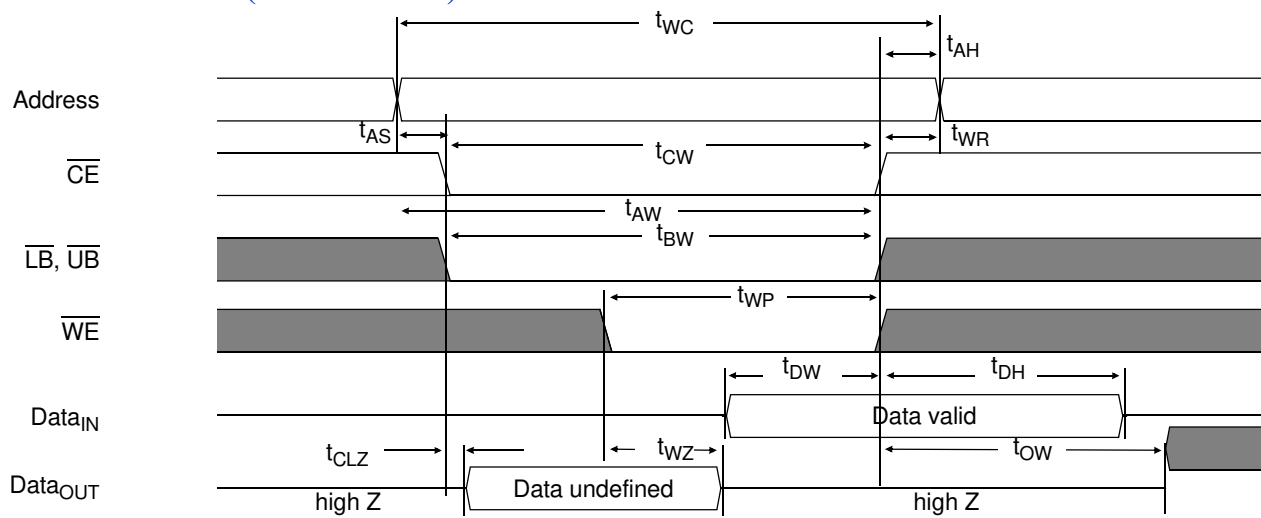



AC test conditions

- Output load: see Figure B.
- Input pulse level: GND to 3.5 V. See Figure A.
- Input rise and fall times: 2 ns. See Figure A.
- Input and output timing reference levels: 1.5

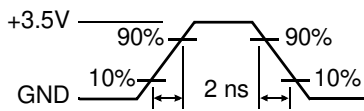

Figure A: Input pulse

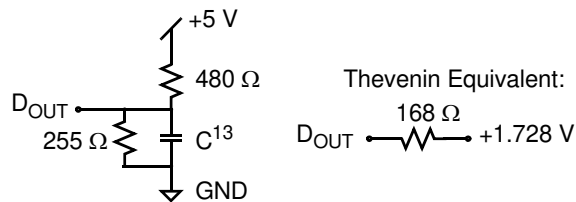

Figure B: 5 V Output load

Notes

- 1 During V_{CC} power-up, a pull-up resistor to V_{CC} on \overline{CE} is required to meet I_{SB} specification.
- 2 This parameter is sampled, but not 100% tested.
- 3 For test conditions, see *AC Test Conditions*, Figures A and B.
- 4 These parameters are specified with $C_L = 5$ pF, as in Figures B. Transition is measured ± 500 mV from steady-state voltage.
- 5 This parameter is guaranteed, but not tested.
- 6 \overline{WE} is high for read cycle.
- 7 \overline{CE} and \overline{OE} are low for read cycle.
- 8 Address is valid prior to or coincident with \overline{CE} transition low.
- 9 All read cycle timings are referenced from the last valid address to the first transitioning address.
- 10 N/A.
- 11 All write cycle timings are referenced from the last valid address to the first transitioning address.
- 12 Not applicable.
- 13 $C = 30$ pF, except all high Z and low Z parameters where $C = 5$ pF.



Package dimensions

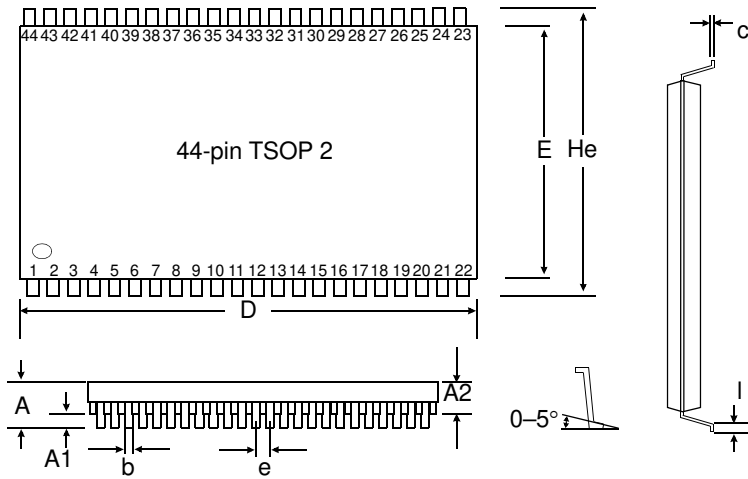

	44-pin TSOP 2	
	Min (mm)	Max (mm)
A		1.2
A1	0.05	0.15
A2	0.95	1.05
b	0.30	0.45
c	0.120	0.21
D	18.31	18.52
E	10.06	10.26
He	11.68	11.94
e	0.80 (typical)	
l	0.40	0.60

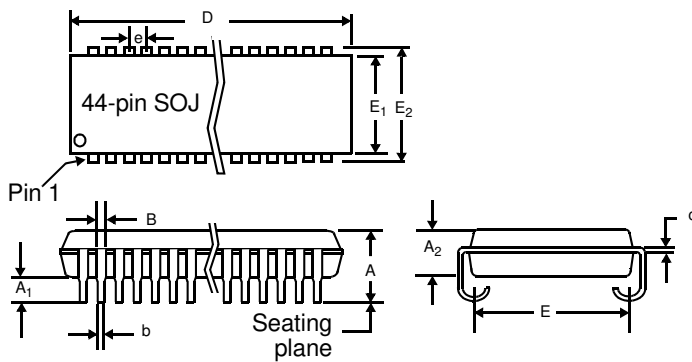

	44-pin SOJ 400 mil	
	Min (in)	Max (in)
A	0.128	0.148
A1	0.025	-
A2	0.105	0.115
B	0.026	0.032
b	0.015	0.020
c	0.007	0.013
D	1.120	1.130
E	0.370 NOM	
E1	0.395	0.405
E2	0.435	0.445
e	0.050 NOM	



Ordering codes

Package \ Access time	Temp	10 ns	12 ns	15 ns	20 ns
Plastic SOJ, 400 mil	commercial	AS7C1026B-10JC	AS7C1026B-12JC	AS7C1026B-15JC	AS7C1026B-20JC
	industrial	AS7C1026B-10JI	AS7C1026B-12JI	AS7C1026B-15JI	AS7C1026B-20JI
TSOP 2, 10.2 x 18.4 mm	commercial	AS7C1026B-10TC	AS7C1026B-12TC	AS7C1026B-15TC	AS7C1026B-20TC
	industrial	AS7C1026B-10TI	AS7C1026B-12TI	AS7C1026B-15TI	AS7C1026B-20TI

Note: Add suffix 'N' to the above ordering part number for LEAD FREE PARTS (Ex: AS7C1026B-10JCN)

Part numbering system

AS7C	1026B	-XX	X	X	X
SRAM prefix	Device number	Access time	Package: J = SOJ 400 mil T = TSOP 2, 10.2 x 18.4 mm	Temperature range: C = commercial: 0° C to 70° C I = industrial: -40° C to 85° C	N = LEAD FREE PART



Alliance Semiconductor Corporation

2575, Augustine Drive,

Santa Clara, CA 95054

Tel: 408 - 855 - 4900

Fax: 408 - 855 - 4999

www.alsc.com

Copyright © Alliance Semiconductor

All Rights Reserved

Part Number: AS7C1026B

Document Version: v 1.3

© Copyright 2003 Alliance Semiconductor Corporation. All rights reserved. Our three-point logo, our name and Intelliwatt are trademarks or registered trademarks of Alliance. All other brand and product names may be the trademarks of their respective companies. Alliance reserves the right to make changes to this document and its products at any time without notice. Alliance assumes no responsibility for any errors that may appear in this document. The data contained herein represents Alliance's best data and/or estimates at the time of issuance. Alliance reserves the right to change or correct this data at any time, without notice. If the product described herein is under development, significant changes to these specifications are possible. The information in this product data sheet is intended to be general descriptive information for potential customers and users, and is not intended to operate as, or provide, any guarantee or warranty to any user or customer. Alliance does not assume any responsibility or liability arising out of the application or use of any product described herein, and disclaims any express or implied warranties related to the sale and/or use of Alliance products including liability or warranties related to fitness for a particular purpose, merchantability, or infringement of any intellectual property rights, except as express agreed to in Alliance's Terms and Conditions of Sale (which are available from Alliance). All sales of Alliance products are made exclusively according to Alliance's Terms and Conditions of Sale. The purchase of products from Alliance does not convey a license under any patent rights, copyrights; mask works rights, trademarks, or any other intellectual property rights of Alliance or third parties. Alliance does not authorize its products for use as critical components in life-supporting systems where a malfunction or failure may reasonably be expected to result in significant injury to the user, and the inclusion of Alliance products in such life-supporting systems implies that the manufacturer assumes all risk of such use and agrees to indemnify Alliance against all claims arising from such use.