



Chipsmall Limited consists of a professional team with an average of over 10 year of expertise in the distribution of electronic components. Based in Hongkong, we have already established firm and mutual-benefit business relationships with customers from,Europe,America and south Asia,supplying obsolete and hard-to-find components to meet their specific needs.

With the principle of “Quality Parts,Customers Priority,Honest Operation,and Considerate Service”,our business mainly focus on the distribution of electronic components. Line cards we deal with include Microchip,ALPS,ROHM,Xilinx,Pulse,ON,Everlight and Freescale. Main products comprise IC,Modules,Potentiometer,IC Socket,Relay,Connector.Our parts cover such applications as commercial,industrial, and automotives areas.

We are looking forward to setting up business relationship with you and hope to provide you with the best service and solution. Let us make a better world for our industry!



Contact us

Tel: +86-755-8981 8866 Fax: +86-755-8427 6832

Email & Skype: info@chipsmall.com Web: www.chipsmall.com

Address: A1208, Overseas Decoration Building, #122 Zhenhua RD., Futian, Shenzhen, China



ASEK21-T-KIT Quick Guide

The ASEK-21-T-KIT as described below is for the purpose of programming customer modules that contain multiple Allegro devices.

ASEK21 T-KIT Bill of Materials

- ASEK-21 Main Board(Part #: 85-0712)
- ASEK-21 Calibration Board(Part #: 85-0712-100)
- ASEK-21 Daughter Board(Part #: 85-0712-103)
- ASEK-21 Cable(Part #: 85-0712-301)
- USB A male to B male 3 foot cable (Part#: 3021001-03)
- ASEK-21 Power Supply (Part #: EMMA050400-P5P-1C)

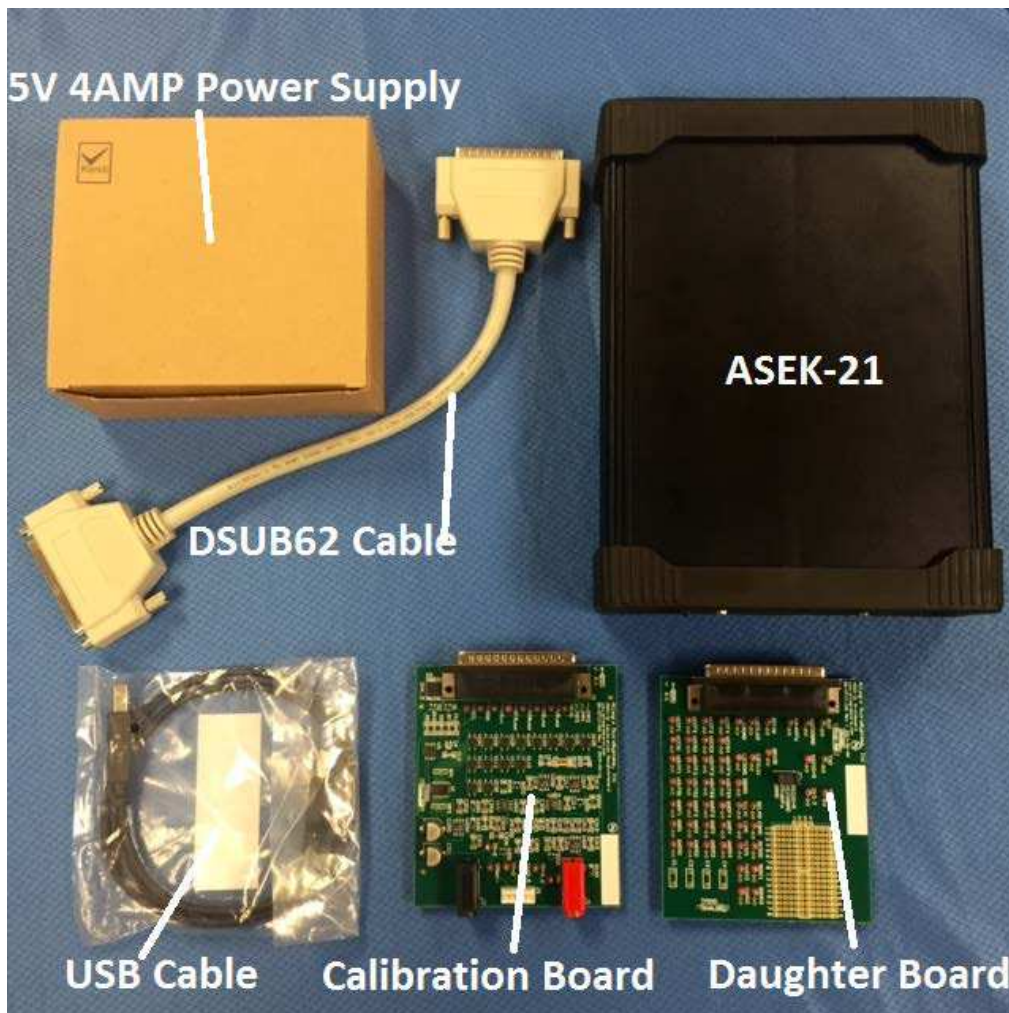

Figure 1: Complete ASEK21 Kit

Instructions for Configuring ASEK-21-T-KIT for Device Programming

1. Connect one end of the USB cable to a personal computer
2. Connect the other end of the USB cable to the USB port on the ASEK-21.
3. Connect the DSUB62 cable to ASEK-21 and the other end to J4 connector on the ASEK-21 daughterboard board (85-0712-103).
4. Connect the DC Power Supply/Cable to the 5V port on the ASEK-21.
5. Plug in the DC Power Supply to a 110V/220AC 60/50Hz outlet with the proper adapter
6. Complete setup is shown in Figure 2

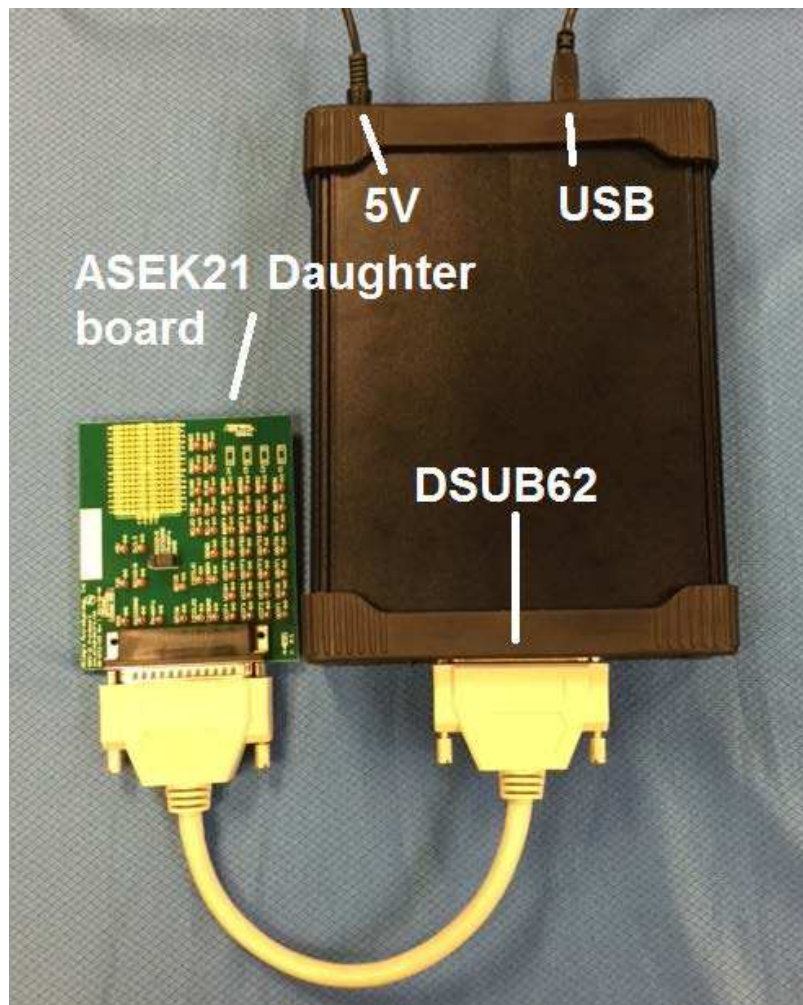

Figure 2: Assembled ASEK21

Daughterboard Pinout and Jumpers

It is advised to remove all 4 jumpers in the image below, and place them on one side of the pins for safe storage. Jumpers may be necessary in very specific applications (RS232, sensor modules without i2C pull up resistors).

ASEK21 daughterboard supports multiple communication protocols. Figure 3 below shows test points for analog, i2c and SPI communications. Note: Analog test **REQUIRES** the connection of kelvin contacts either on the daughterboard or at the sensor module.

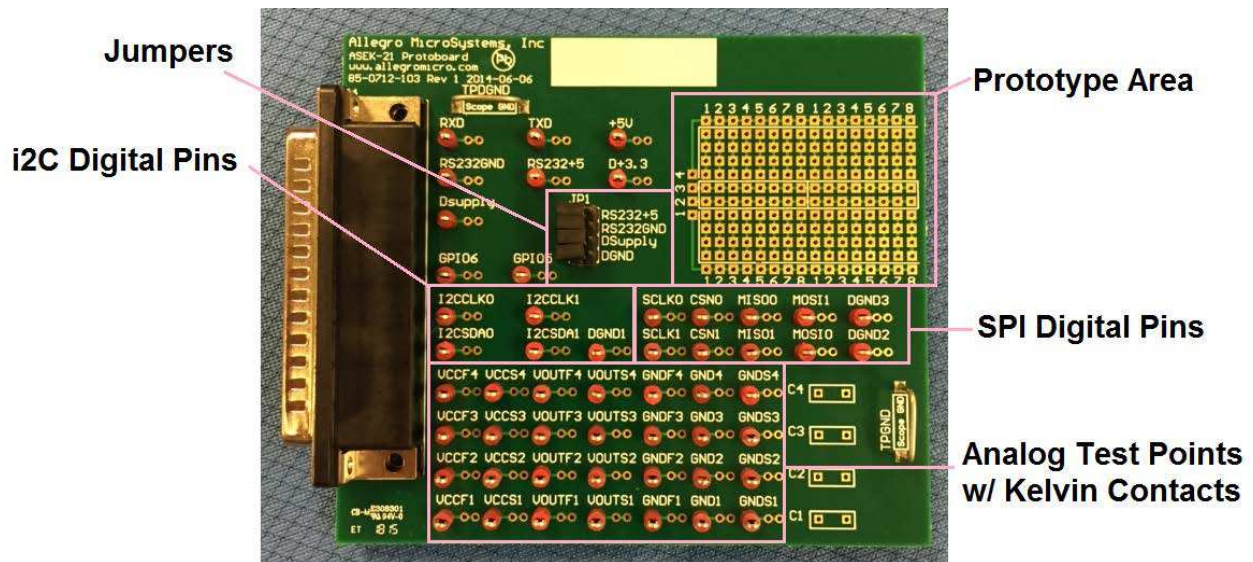

Figure 3: ASEK21 daughterboard

Refer to Table 1 through Table 4 below for daughterboard pin names and brief description of their function. Refer to Table 5 for information regarding jumpers.

Pin Name	Description	Provided/Driven by
MOSIO	Master out, Slave in 0	ASEK-21
MISO0	Master in, Slave out 0	Sensor Module
SCLK0	SPI Clock 0	ASEK-21
CSN0	Chip Select 0	ASEK-21
MOSI1	Master out, Slave in 1	ASEK-21
MISO1	Master in, Slave out 1	Sensor Module
SCLK1	SPI Clock 1	ASEK-21
CSN1	Chip Select 1	ASEK-21

Table 1: SPI channels 1 and 2 on ASEK21 daughterboard

Pin Name	Description	Provided/Driven by
I2CSDA0	I ² C Data Channel 0	ASEK-21/Sensor Module
I2CCLK0	I ² C Clock Channel 0	ASEK-21
I2CSDA1	I ² C Data Channel 1	ASEK-21/Sensor Module
I2CCLK1	I ² C Clock Channel 1	ASEK-21

Table 2: i²C channels 1 and 2 on ASEK21 daughterboard

Signal	Description	Provided/Driven by
VCC_F_S1	VCC Force Sensor 1	ASEK-21
VCC_S_S1	VCC Sense Sensor 1	Sensor Module
VOUT_F_S1	VOUT Force Sensor 1	ASEK-21
VOUT_S_S1	VOUT Sense Sensor 1	Sensor Module
GND_F_S1	Ground Force Sensor 1	ASEK-21
GND_S_S1	Ground Sense Sensor 1	Sensor Module
VCC_F_S2	VCC Force Sensor 2	ASEK-21
VCC_S_S2	VCC Sense Sensor 2	Sensor Module
VOUT_F_S2	VOUT Force Sensor 2	ASEK-21
VOUT_S_S2	VOUT Sense Sensor 2	Sensor Module
GND_F_S2	Ground Force Sensor 2	ASEK-21
GND_S_S2	Ground Sense Sensor 2	Sensor Module
VCC_F_S3	VCC Force Sensor 3	ASEK-21
VCC_S_S3	VCC Sense Sensor 3	Sensor Module
VOUT_F_S3	VOUT Force Sensor 3	ASEK-21
VOUT_S_S3	VOUT Sense Sensor 3	Sensor Module
GND_F_S3	Ground Force Sensor 3	ASEK-21
GND_S_S3	Ground Sense Sensor 3	Sensor Module
VCC_F_S4	VCC Force Sensor 4	ASEK-21
VCC_S_S4	VCC Sense Sensor 4	Sensor Module
VOUT_F_S4	VOUT Force Sensor 4	ASEK-21
VOUT_S_S4	VOUT Sense Sensor 4	Sensor Module
GND_F_S4	Ground Force Sensor 4	ASEK-21
GND_S_S4	Ground Sense Sensor 4	Sensor Module

Table 3: Analog Channels 1 through 4 on ASEK21 daughterboard. **Note:** Analog testing requires the connection of kelvin contacts either on the daughterboard or at the sensor module.

Signal	Description	Provided/Driven by
Dsupply * ¹	Digital Power Supply	Sensor Module
D+3.3 * ²	Digital +3.3V Test Point	Sensor Module
+5V	5V Test Point	ASEK-21
GPIO5	GPIO 5	ASEK-21
GPIO6	GPIO 6	ASEK-21
RS232+5V * ³	RS232 +5V	RS232
RS232GND * ³	RS232 Ground	RS232
TXD	RS232 Transmit	RS232
RXD	RS232 Receive	RS232
DGND	Digital Ground	Sensor Module
DGND	Digital Ground	Sensor Module
TPGND	Scope Ground Bar	ASEK-21

Table 4: Other Pins on ASEK21 daughterboard. See notes below regarding limits

***¹ Dsupply**

- Do not supply negative voltages
- Do not supply voltage exceeding +5.5V
- Do not apply voltage if providing digital voltage (+2.7 V, +3.3V or +5V) to module with ASEK21
- Voltages applied to Dsupply should be in reference to DGND

***² D+3.3**

- Do not supply negative voltages
- Do not supply voltages exceeding +5.5V
- Voltages applied to D+3.3 should be in reference to DGND

***³ RS232+5V/GND**

- Do not supply negative voltages
- Do not supply voltages outside of +3.3 to +5.5V
- Voltages applied to D+3.3 should be in reference to DGND

Jumper	Function
RS232+5	Required to enable RS232
RES232GND	Required to enable RS232
Dsupply	Will connect module Dsupply to ASEK21 Dsupply
DGND	Will connect module DGND to ASEK21 GND

Table 5: Jumpers on ASEK21 daughterboard

Setting up USB Connection

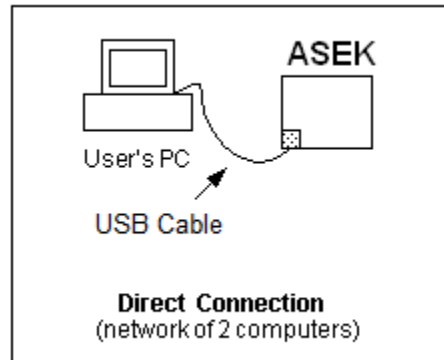

Figure 4: Options for Connecting ASEK to PC

Windows will treat ASEK21 as a serial com port. The first time ASEK-21 is connected to the computer windows will look for and install the necessary drivers. The exact port number can be found using the device manager under "Ports." See Table 5.

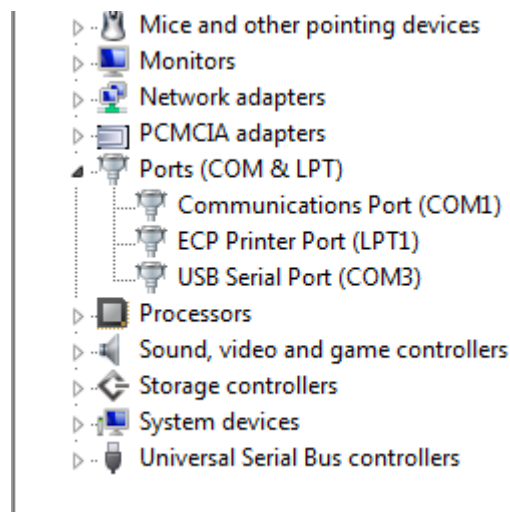

Figure 5: Screenshot from Windows device manager showing ASEK-21 as a USB Serial Port (COM3)

8 July 2015



Programming Software for ASEK-21-T-KIT

1. Register at Allegro's software portal in order to download the ASEK21 programming software. <https://registration.allegromicro.com/login>

Revision History Table

Revision	Change Description	Res.	Page(s)	Date
-	Original release	WB	All	8 July, 2015