



Chipsmall Limited consists of a professional team with an average of over 10 year of expertise in the distribution of electronic components. Based in Hongkong, we have already established firm and mutual-benefit business relationships with customers from,Europe,America and south Asia,supplying obsolete and hard-to-find components to meet their specific needs.

With the principle of “Quality Parts,Customers Priority,Honest Operation,and Considerate Service”,our business mainly focus on the distribution of electronic components. Line cards we deal with include Microchip,ALPS,ROHM,Xilinx,Pulse,ON,Everlight and Freescale. Main products comprise IC,Modules,Potentiometer,IC Socket,Relay,Connector.Our parts cover such applications as commercial,industrial, and automotives areas.

We are looking forward to setting up business relationship with you and hope to provide you with the best service and solution. Let us make a better world for our industry!



Contact us

Tel: +86-755-8981 8866 Fax: +86-755-8427 6832

Email & Skype: info@chipsmall.com Web: www.chipsmall.com

Address: A1208, Overseas Decoration Building, #122 Zhenhua RD., Futian, Shenzhen, China



ASEK71020 Evaluation Board

ACS71020 DEMO BOARD AND COMPONENTS

Allegro ACS71020 demo board is pictured in Figure 1 below. Refer to Table 1 for symbol names and descriptions of onboard components. Note: Board is pictured without capacitors and resistors attached.

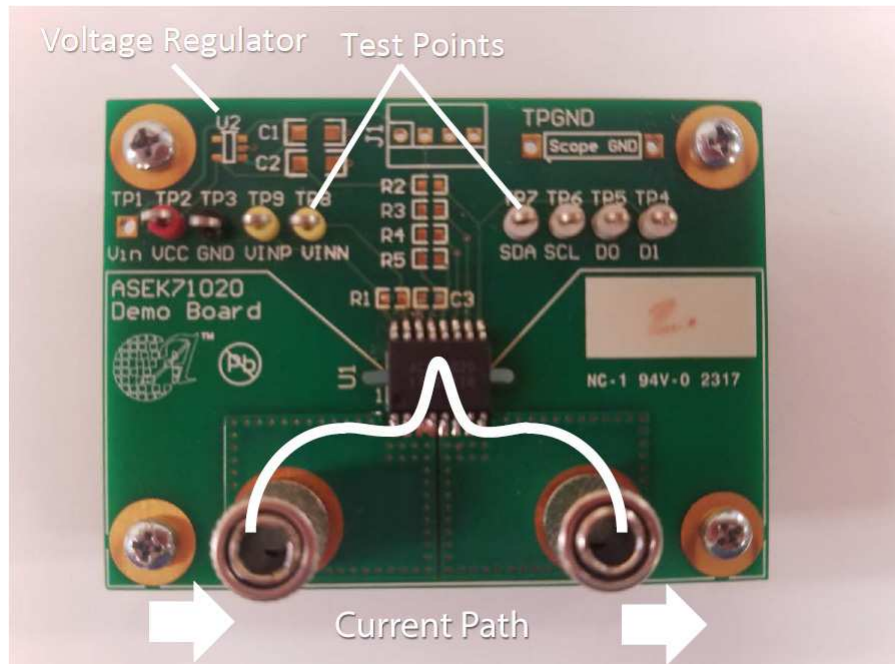

Figure 1: Allegro ACS71020 Current Sensor Demo Board

Table 1: Summary of Demo Board Components

Symbol	Description
U1	Location of Allegro ACS71020
U2	Voltage regulator
C1/C2	0.1 μ F regulator capacitors
C3	0.1 μ F device bypass capacitor
R1	R_{SENSE} resistor voltage step down circuit. Application specific.
R2-R5	Digital I/O pull-up resistors (used for SPI or I ² C communication)

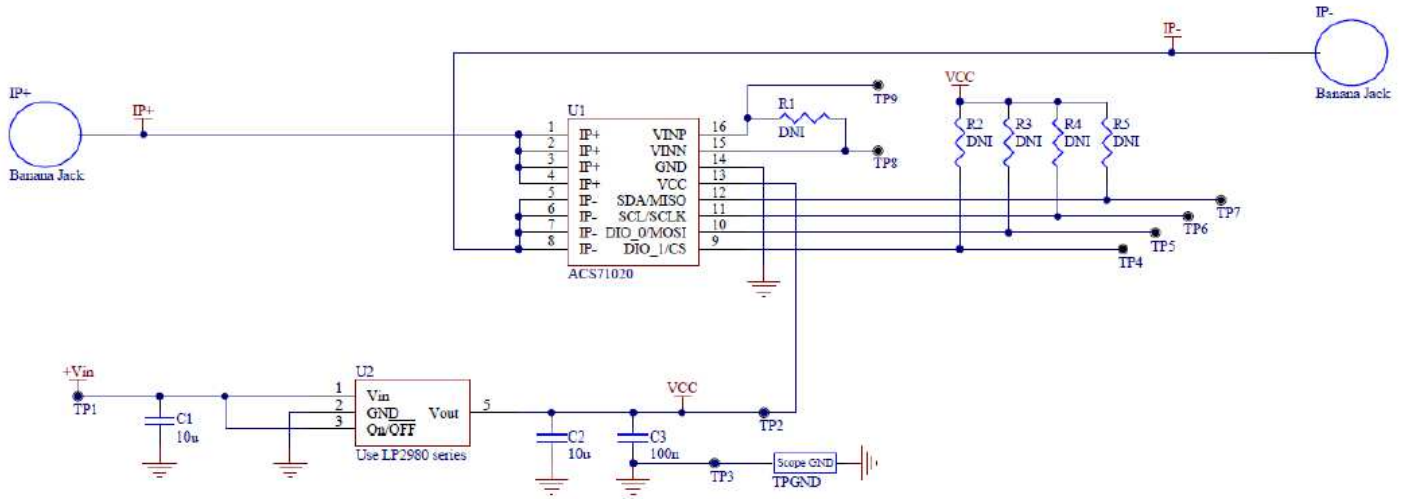
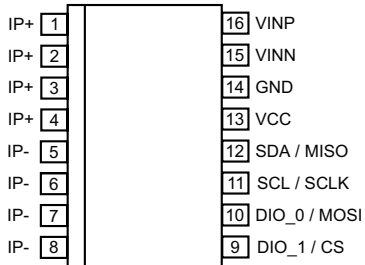

Figure 2: Schematic for ACS71020 Demo Board

PINOUT DIAGRAM AND TERMINAL LIST



Pinout Diagram

Table 2: Terminal List Table

Number	Name	Description	
		I2C	SPI
1, 2, 3, 4	IP+	Terminals for current being sensed; fused internally	
5, 6, 7, 8	IP-	Terminals for current being sensed; fused internally	
9	DIO_1/CS	Digital I/O 1	Chip Select (CS)
10	DIO_0/MOSI	Digital I/O 0	MOSI
11	SCL/SCLK	SCL	SCLK
12	SDA / MISO	SDA	MISO
13	VCC	Device power supply terminal	
14	GND	Device Power and Signal ground terminal	
15	VINN	Negative Input Voltage	
16	VINP	Positive Input Voltage	

ACS71020 Recommended Application Circuit

A resistor divider circuit shall be used to step down measured the voltage of the system. The voltage across VINP and VINN shall not exceed 275 mV as stated in the datasheet. This application example steps the voltage down to ± 250 mV for expected V_{peak} . The standard application schematic is shown in Figure 3. Refer to the ACS71020 device datasheet for more information.

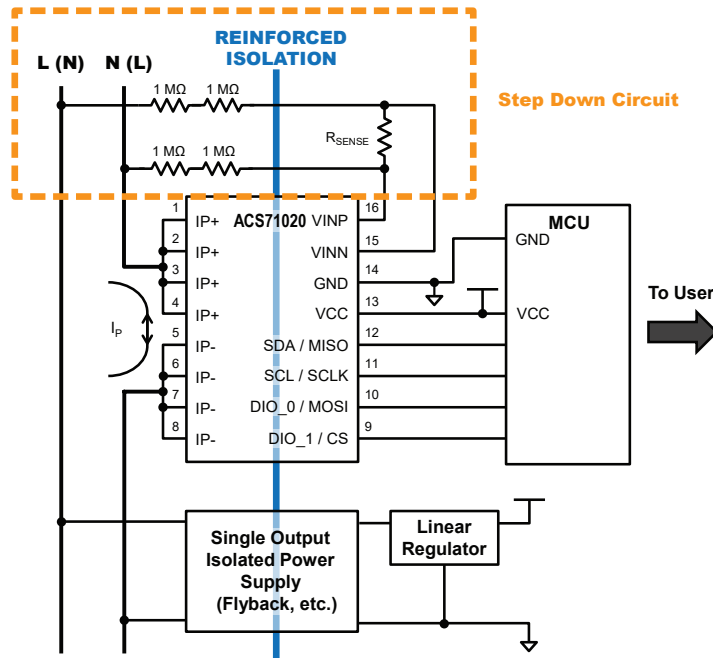

Figure 3: Recommended Application Circuit from Datasheet

Step Down Circuit

Figure 4 shows the step down application circuit in finer detail. The appropriate value for the sense resistor “R” shall be determined by the user as to not exceed 275 mV across VINP and VINN.

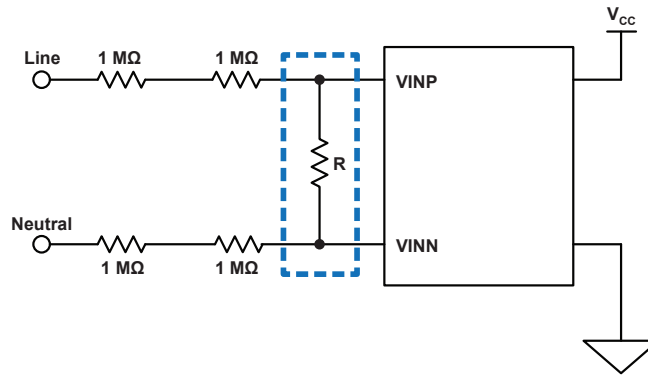

Figure 4: Step Down Circuit

Table 3 shows recommended resistor values for popular application voltages, and assumes the step down circuit in Figure 4.

Table 3: Recommended R_{SENSE} based on V_{RMS}

V_{RMS} (V)	V_{peak} (V)	Range of V_{IN} (V)	R Max (Ω)	R_{SENSE} Recommended (k Ω)
50	70.7	0.25	14194	13
100	141.4	0.25	7085	5.6
110	155.54	0.25	6440	5.1
120	169.68	0.25	5902	4.7
150	212.1	0.25	4720	3.9
220	311.08	0.25	3217	2.2
240	339.36	0.25	2949	1.8

Revision History

Number	Date	Description
-	July 12, 2017	Initial Release

Copyright ©2018, Allegro MicroSystems, LLC

The information contained in this document does not constitute any representation, warranty, assurance, guaranty, or inducement by Allegro to the customer with respect to the subject matter of this document. The information being provided does not guarantee that a process based on this information will be reliable, or that Allegro has explored all of the possible failure modes. It is the customer's responsibility to do sufficient qualification testing of the final product to ensure that it is reliable and meets all design requirements.

Copies of this document are considered uncontrolled documents.

For the latest version of this document, visit our website:

www.allegromicro.com



Allegro MicroSystems, LLC
955 Perimeter Road
Manchester, NH 03103-3353 U.S.A.
www.allegromicro.com