



Chipsmall Limited consists of a professional team with an average of over 10 year of expertise in the distribution of electronic components. Based in Hongkong, we have already established firm and mutual-benefit business relationships with customers from,Europe,America and south Asia,supplying obsolete and hard-to-find components to meet their specific needs.

With the principle of "Quality Parts,Customers Priority,Honest Operation,and Considerate Service",our business mainly focus on the distribution of electronic components. Line cards we deal with include Microchip,ALPS,ROHM,Xilinx,Pulse,ON,Everlight and Freescale. Main products comprise IC,Modules,Potentiometer,IC Socket,Relay,Connector.Our parts cover such applications as commercial,industrial, and automotives areas.

We are looking forward to setting up business relationship with you and hope to provide you with the best service and solution. Let us make a better world for our industry!



Contact us

Tel: +86-755-8981 8866 Fax: +86-755-8427 6832

Email & Skype: info@chipsmall.com Web: www.chipsmall.com

Address: A1208, Overseas Decoration Building, #122 Zhenhua RD., Futian, Shenzhen, China



ASL2416SHN

Enhanced two channel LED buck driver

Rev. 5.1 — 26 October 2017

Product data sheet

1. Introduction

The ASL2416SHN is a two channel buck mode LED driver IC delivering constant average DC current to LEDs independent of the input voltage. The ASL2416SHN supports up to two output channels. It means that with one driver IC, 1 or 2 LED strings can be driven independently of each other. It provides a cost effective design solution, specifically targeting automotive exterior and interior lighting applications.

2. General description

The ASL2416SHN has a hysteretic buck DC-to-DC topology. With input voltages from 10 V to 80 V, it allows maximum flexibility on output voltages for each channel, enabling applications with up to 20 LEDs. It also provides an output current of up to and above 1.5 A per channel.¹ Furthermore, two output channels can be connected together to provide an even higher current. It drives an external high-side N channel MOSFET from an internally regulated adjustable supply. The ASL2416SHN buck driver gives a flexible system design which can be used to drive two LED strings with the same architecture.

The ASL2416SHN provides an SPI interface for extensive control and diagnostic communication with an external microcontroller.

The ASL2416SHN offers an adjustable hysteresis for optimizing external components as well as minimizing LED current ripple.

In addition, the ASL2416SHN provides an output voltage of up to 70 V. It has a measurement capability that can be used to identify LED open or short circuit conditions. The microcontroller can read this voltage and use it to detect open or short circuit conditions. There are also additional diagnostic features such as current reached status.

Additional features include input under-voltage lockout and thermal shutdown when the junction temperature of the ASL2416SHN exceeds +175 °C.

It is housed in a very small HVQFN32 pin package with an exposed thermal pad and is designed to meet the stringent requirements of automotive applications. It is fully AEC Q100 grade 1 qualified. It operates over the ambient automotive temperature range of -40 °C to +125 °C.

1. The ASL2416 provides an accurate current over a 1 : 12.5 range. This range can be scaled up or down using external components. Depending on the operating conditions and component choices, output currents of min 30 mA and more than 3 A can be achieved.



3. Features and benefits

- The ASL2416SHN is an automotive grade product that is AEC-Q100 grade 1 qualified.
- Operating ambient temperature range of $-40\text{ }^{\circ}\text{C}$ to $+125\text{ }^{\circ}\text{C}$
- Wide operating input voltage range from $+10\text{ V}$ to $+80\text{ V}$
- Able to drive up to 20 LEDs, wide operating LED voltage range regulated from 2.5 V to 70 V
- Output current of up to and above 1.5 A with high LED current accuracy of $\pm 5\%$ over the complete operating temperature range
- Output current programmable via SPI interface
- Read back programmed current via SPI
- Two output current ranges, programmable via SPI interface with 5% accuracy
- Hysteretic converter
- Fast gate drive for high efficiency
- Programmable internal gate driver voltage regulator
- Support logic level and standard level FETs
- Integrated bootstrap diode
- PWM inputs for individual dimming of each channel
- Low Electro Magnetic Emission (EME) and high Electro Magnetic Immunity (EMI)
- Input voltage monitoring and input under voltage protection
- Output voltage monitoring
- Control signal to enable the device
- Junction temperature monitoring via SPI
- Small package outline HVQFN32
- Low quiescent current $<5\text{ }\mu\text{A}$ at $25\text{ }^{\circ}\text{C}$ when $\text{EN} = 0$
- Short-circuit and open-circuit output protection

4. Applications

- Automotive LED lighting
 - Daytime running lights
 - ◆ Position or park light
 - ◆ Low beam
 - ◆ High beam
 - ◆ Turn indicator
 - ◆ Fog light
 - ◆ Cornering light
 - ◆ Advanced front lighting

5. Ordering information

Table 1. Ordering information

Type number	Package		Version
	Name	Description	
ASL2416SHN	HVQFN32	plastic thermal enhanced very thin quad flat package; no leads; 32 terminals; body 5 × 5 × 0.85 mm	SOT617-12

6. Block diagram

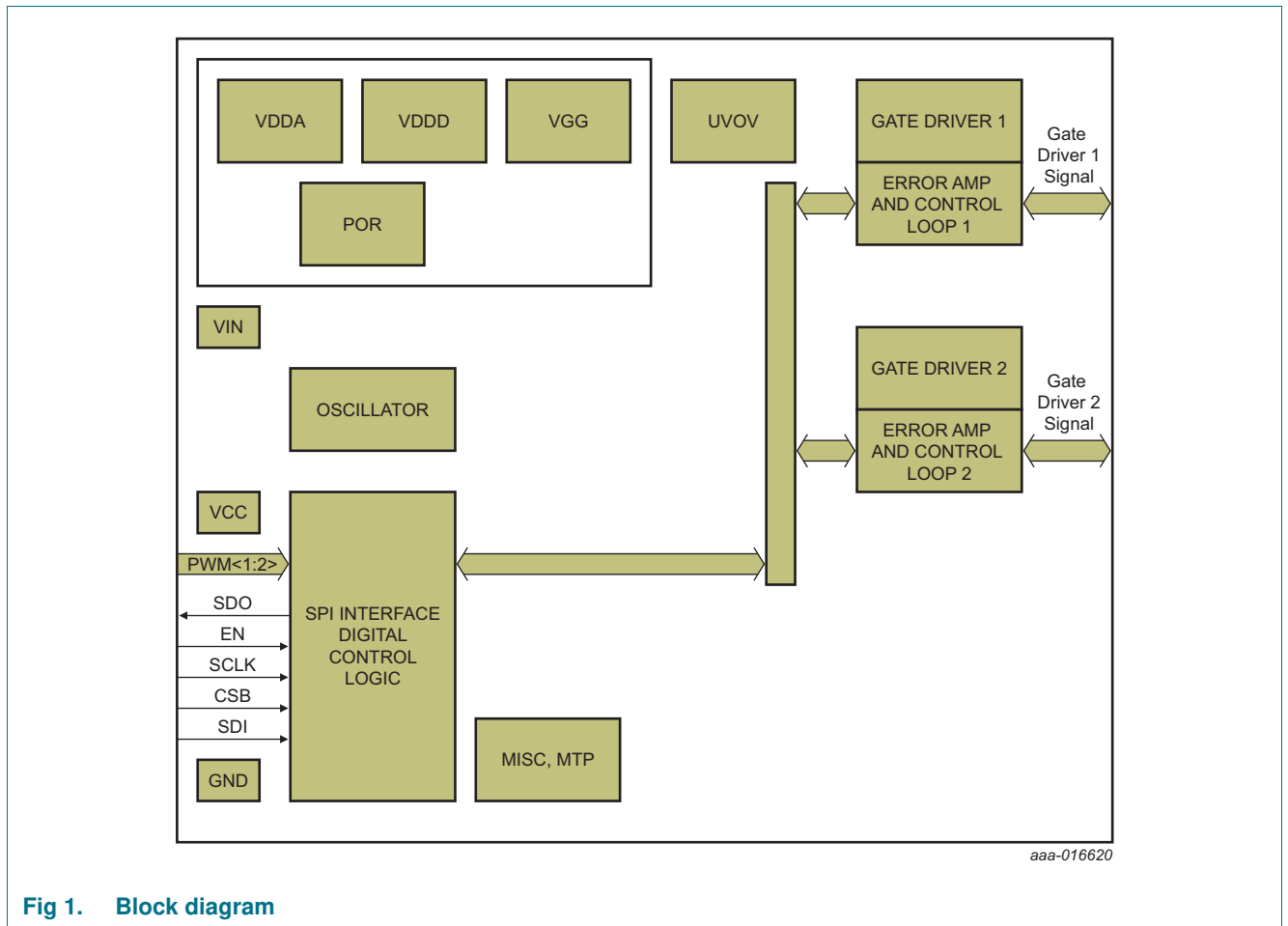
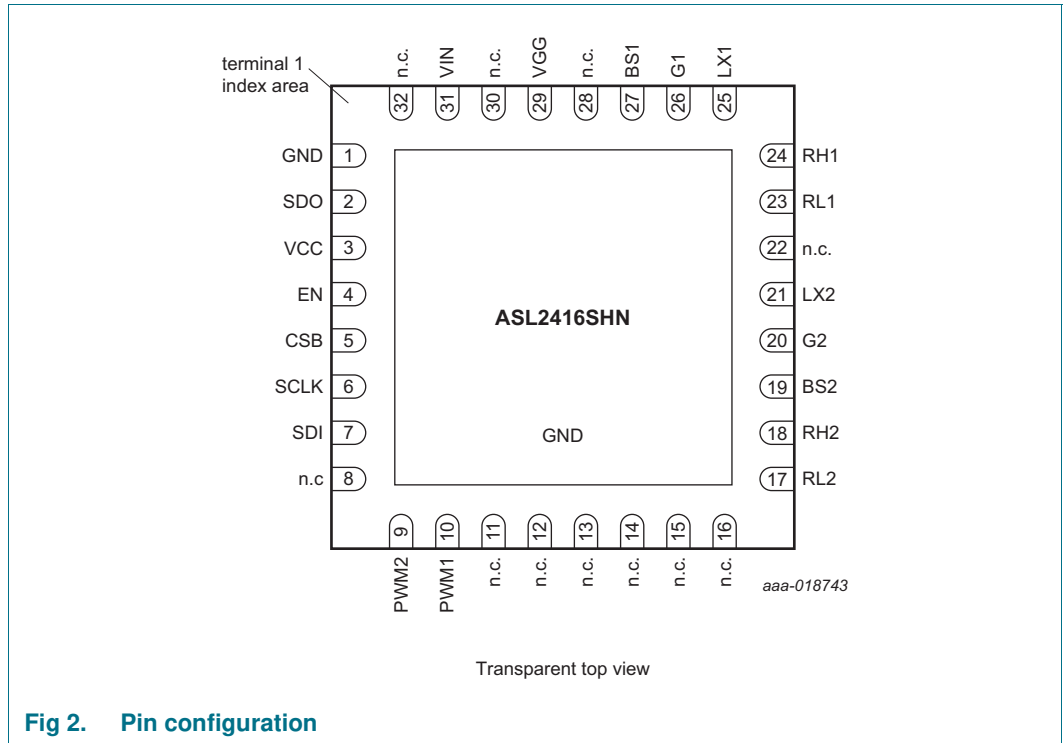

Fig 1. Block diagram

7. Pinning information

7.1 Pinning



7.2 Pin description

Table 2. Pin description[1]

Symbol	Pin	Description
GND	1	chip ground
SDO	2	SPI data out
VCC	3	external 5 V supply
EN	4	enable signal
CSB	5	SPI chip select
SCLK	6	SPI Clock
SDI	7	SPI data input
n.c.	8	not connected
PWM2	9	external PWM signal channel 2
PWM1	10	external PWM signal channel 1
n.c.	11	not connected
n.c.	12	not connected
n.c.	13	not connected
n.c.	14	not connected
n.c.	15	not connected
n.c.	16	not connected

Table 2. Pin description^[1]...continued

Symbol	Pin	Description
RL2	17	sense resistor low side channel 2
RH2	18	sense resistor high side channel 2
BS2	19	boot supply channel 2
G2	20	channel 2 gate driver
LX2	21	inductor connection to switching FET channel 2
n.c.	22	not connected
RL1	23	sense resistor low side channel 1
RH1	24	sense resistor high side channel 1
LX1	25	inductor connection to switching FET channel 1
G1	26	channel 1 gate driver
BS1	27	boot supply channel 1
n.c.	28	not connected
VGG	29	gate driver supply
n.c.	30	not connected
VIN	31	input voltage
n.c.	32	not connected

[1] Not connected (n.c.) pins are internally not connected and must be left floating to maintain high-voltage separation.

For enhanced thermal and electrical performance, the exposed center pad of the package should be soldered to board ground (and not to any other voltage level).

8. Functional description

8.1 Operating modes

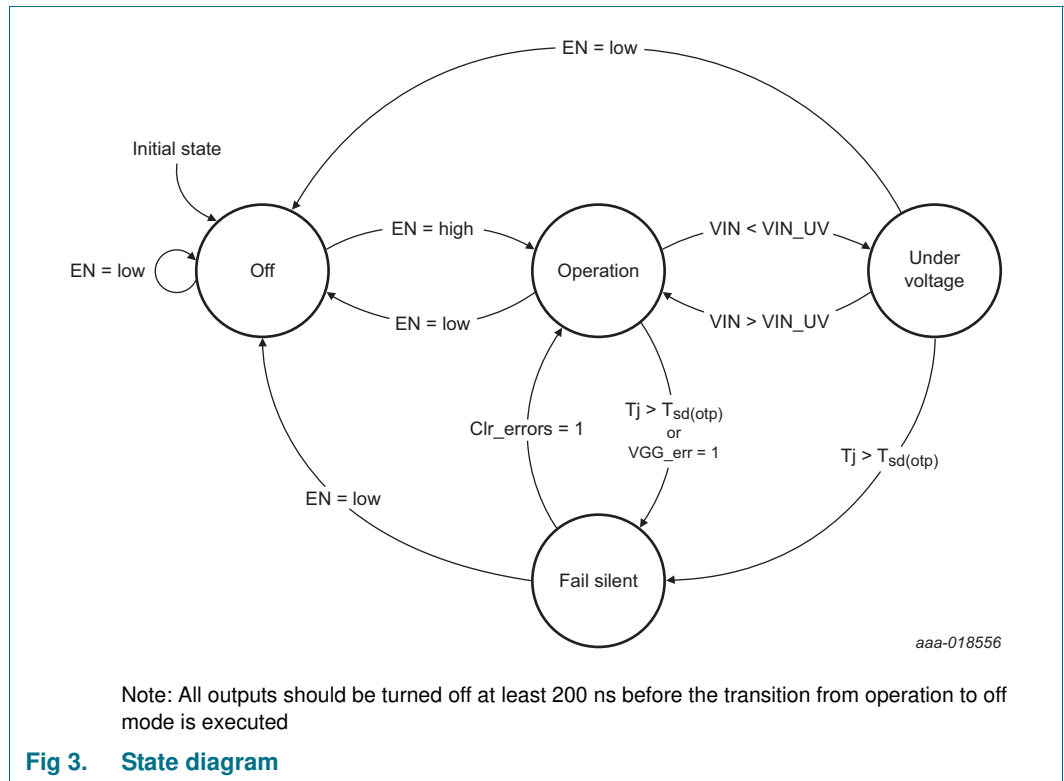

8.1.1 Off mode

If the input voltage drops below the power-off detection threshold ($V_{th(det)pooff}$) or the EN pin is low, the ASL2416SHN switches to off mode.

In Off mode, the SPI interface and all outputs are turned off. Before Off mode is entered, all channels should be turned off.

8.1.2 Operation mode

The ASL2416SHN switches from Off mode to Operation mode when the input voltage is above the power-on detection threshold ($V_{th(det)pon}$) and the EN pin is high. In Operation mode, all outputs are available as configured via the SPI interface.

8.1.3 Under voltage mode

The ASL2416SHN switches from Operation mode to Under voltage mode as soon as the input voltage drops below the programmed voltage. In Under voltage mode, all outputs, including the gate voltage supply are off.

8.1.4 Fail silent mode

The ASL2416SHN switches from Operation mode to Fail silent mode, when the junction temperature exceeds the over temperature shutdown threshold or a gate driver error is detected.

In Fail silent mode, all outputs are turned off and only the SPI interface remains operational.

8.2 Buck converter

The ASL2416SHN is a buck converter IC delivering constant current to the LEDs. It is a hysteretic controller that regulates the inductor current. It switches off the external FET when the inductor current rises above the upper threshold current. It switches on when the current falls below the lower threshold. The width of the hysteresis window can be programmed via SPI to keep the switching frequency between bounds. The anode of the LED string is connected to the driver, while the cathode of the LED string is connected to ground. This arrangement helps to reduce the total number of connections to the LEDs.

8.3 Input voltage measurement

The ASL2416SHN measures the supply voltage of the device and makes this measurement available via the SPI interface.

Table 3. VIN voltage measurement register, address 0x38h^[1]

Bit	Symbol	Description	Value	Function
7:0	V_VIN[7:0]	VIN voltage measurement	0x00h	voltage measurement not available
			...	VIN voltage = 0.3548 × V_VIN[7:0] – 0.56 V

[1] A write to the VIN voltage measurement register does not set the SPI error bit high.

8.4 Input under voltage detection

The ASL2416SHN offers a variable undervoltage detection threshold.

When the supply voltage is above the under voltage detection threshold, the bit VIN_stat is high, when the supply voltage is below, the bit is low.

For effects of this bit on the functionality of the device, see [Section 8.12.1.1](#).

Table 4. Undervoltage threshold register, address 0x0Fh

Bit	Symbol	Description	Value	Function
7:0	V_VIN_UV[7:0]	undervoltage threshold	0x00h	undervoltage detection threshold = 0 V
			...	undervoltage detection threshold = 0.3548 × V_VIN_UV[7:0] – 0.56 V

8.5 Output current programmability

The ASL2416SHN provides the possibility to program the LED current and LED current hysteresis via the SPI interface.

8.5.1 Output target current programming

The target output current of the ASL2416SHN can be programmed via the LED current range registers and the LED current registers of channel 1 and channel 2. The sense voltage that is set via SPI, and the value of the external sense resistor, determine the actual level.

$$I_{LED} = \frac{V_{LEDcurrent}}{R_{sense}} \quad (1)$$

Table 5. LED current range register, address 0x05h

Bit	Symbol	Description	Value	Function
7:2		reserved	000000	reserved; keep clear for future use
1	I_CH2	LED current range bit channel 2	0	maximum sense voltage is approximately 300 mV
			1	maximum sense voltage is approximately 120 mV
0	I_CH1	LED current range bit channel 1	0	maximum sense voltage is approximately 300 mV
			1	maximum sense voltage is approximately 120 mV

Table 6. LED current channel 1 register, address 0x02h

Bit	Symbol	Description	Value	Function
7:0	I_LED_CH1[7:0]	LED current channel 1	0x00h; 0xF6h...0xFFh	not recommended
			...	When I_CH1 is 0: $1.179 \text{ mV} \times I_{\text{LED_CH1}} + 0.74 \text{ mV}$
				When I_CH1 is 1: $0.47882 \text{ mV} \times I_{\text{LED_CH1}} - 0.6 \text{ mV}$

Table 7. LED current channel 2 register, address 0x03h

Bit	Symbol	Description	Value	Function
7:0	I_LED_CH2[7:0]	LED current channel 2	0x00h; 0xF6h...0xFFh	not recommended
			...	When I_CH2 is 0: $1.179 \text{ mV} \times I_{\text{LED_CH2}} + 0.74 \text{ mV}$
				When I_CH2 is 1: $0.47882 \text{ mV} \times I_{\text{LED_CH2}} - 0.6 \text{ mV}$

The LED current is the result of the voltage drop across the R_{sense} resistor in mV.

Example:

To achieve an output current of e.g. 300 mA with 200 mΩ R_{sense} resistor on Channel 1, two settings are possible:

1. set bit I_CH1 to 1 and the LED current channel 1 register to 0x80h
2. set bit I_CH1 to 0 and the LED current channel 1 register to 0x33h

For higher granularity and higher accuracy, use setting 1. When the LED current is dynamically adjusted to higher levels than offered when bit I_CHx = 1, deviations are possible.

8.5.2 Hysteresis programming via SPI

ASL2416SHN provides an option to program the level of hysteresis via the SPI interface. The hysteresis setting is independent of the I_CH1 and I_CH2 bits in LED current range registers.

The hysteresis voltage that is set via SPI, and the value of the external sense resistor, determine the actual level.

$$I_{\text{Hyst}} = \frac{V_{\text{Hyst}}}{R_{\text{sense}}} \quad (2)$$

The switching frequency varies depending on the hysteresis level, the values of the external components, and the input and the output voltages.

The ASL2416SHN is specified for switching frequencies from 100 kHz to 2 MHz.

Note: For all hysteresis settings, the hysteresis, specified in mV, corresponds with the lowest average LED current in the static characteristics section.

Table 8. Hysteresis channel 1 register, address 0x0Bh

Bit	Symbol	Description	Value	Function
7:2		reserved	000000	reserved; keep clear for future use
1:0	HCH1[1:0]	hysteresis channel 1	00	setting 0
			01	setting 1
			10	setting 2
			11	setting 3

Table 9. Hysteresis channel 2 register, address 0x0Ch

Bit	Symbol	Description	Value	Function
7:2		reserved	000000	reserved; keep clear for future use
1:0	HCH2[1:0]	hysteresis channel 2	00	setting 0
			01	setting 1
			10	setting 2
			11	setting 3

By increasing the hysteresis level, the switching frequency is reduced, leading to less switching events and consequently lower overall switching losses. However, the ripple of the LED current increases.

Calculation example:

A system has 40 V input voltage, an LED voltage of 15 V, a 200 mΩ R_{sense} , and an inductor of 220 μH. It operates with a hysteresis of 20 mV at:

$$f = \frac{1}{T} = \frac{1}{T_{on} + T_{off}} = \frac{1}{I_{Hyst} \cdot \frac{L}{V_{IN} - V_{LED}} + I_{Hyst} \cdot \frac{L}{V_{LED}}} = \frac{V_{IN} \cdot V_{LED} - V_{LED}^2}{I_{Hyst} \cdot L \cdot V_{IN}} \approx 426 \text{ kHz} \quad (3)$$

Remarks:

The calculation above does not account for delays in the switching. Due to these delays, the measured switching frequency is lower than calculated here.

To avoid that the device is operating with undesired settings, pull the PWM pin high only when a channel is completely configured.

In case the PWM functionality is not needed, it is possible to connect the PWM pin directly to pin VCC. In this case, the PWM pin control bits can be used to enable or disable the channel. To avoid operation at an undesired frequency, the hysteresis for the channel should be set before the LED current register is set.

The hysteresis and LED current level can be adapted during operation of the device to enable smooth fade-in/fade-out scenarios down to very low output currents. It does it in combination with the PWM inputs.

8.5.3 Overcurrent protection

The ASL3416SHN offers an overcurrent protection feature in addition to the set trip points to protect the system. If the output voltage suddenly changes very fast, the upper and lower hysteric thresholds may deviate from actual target values. In case the deviation is too large the built-in overcurrent protection feature prevents the system from excessive current build-up.

In case such an event is detected, the gate driver will immediately be turned off for approximately 16 ms after which the system is restarted.

8.5.4 Output diagnostics

The diagnostic options for the outputs are:

- measurement of the output voltages during the LED on and off state - details can be found in [Section 8.6](#)
- indication that the target LED current is reached - details can be found in [Section 8.11](#)
- indication that a channel is operating with low voltage headroom - details can be found in [Section 8.12.3.1](#)

8.6 Output voltage measurement

The ASL2416SHN measures the output voltage of all channels every t_{meas} . On a transition from the PWM pin of a channel, the measurement results are stored in the corresponding registers. The registers V_LEDx_on, contain the voltage information when the PWM input of the channel is high. The registers V_LEDx_off, contain the voltage information when the PWM input is low. It ensures that the registers contain the latest measured value of the individual channels with respect to the status of the PWM pin. If the PWM input of one channel stays constant for $t_{meas(LED)}$, the V_LEDx_on voltage register and the V_LEDx_off voltage register of this channel are updated.

Table 10. LED on voltage channel 1 register, address 0x20h

Bit	Symbol	Description	Value	Function
7:0	V_LED1_on[7:0]	LED on voltage channel 1	0x00h	LED on voltage = 0 V
			...	LED on voltage = $0.3548 \times V_LED1_on[7:0] - 0.56$ V

Table 11. LED off voltage channel 1 register, address 0x21h

Bit	Symbol	Description	Value	Function
7:0	V_LED1_off[7:0]	LED off voltage channel 1	0x00h	LED off voltage = 0 V
			...	LED off voltage = $0.3548 \times V_LED1_off[7:0] - 0.56$ V

Table 12. LED on voltage channel 2 register, address 0x22h

Bit	Symbol	Description	Value	Function
7:0	V_LED2_on[7:0]	LED on voltage channel 2	0x00h	LED on voltage = 0 V
			...	LED on voltage = $0.3548 \times V_LED2_on[7:0] - 0.56$ V

Table 13. LED off voltage channel 2 register, address 0x23h

Bit	Symbol	Description	Value	Function
7:0	V_LED2_off[7:0]	LED off voltage channel 2	0x00h	LED off voltage = 0 V
			...	LED on voltage = $0.3548 \times V_LED2_off[7:0] - 0.56$ V

8.7 External PWM input

The ASL2416SHN provides a dedicated PWM input for each of the two channels. It allows full control over the PWM frequency and duty cycle and allows phase shifting of the PWM cycles to balance the input current variations.

Pin PWM1 controls channel 1, and PWM2 controls channel 2. A high level at the pins represents that the corresponding channel is turned on and the configured current is delivered to the output.

As soon as the pin is pulled high, pin Gx of the corresponding channel starts toggling. It switches the MOSFET attached to the pin on and off and the system starts to deliver the configured output current.

As soon as the pin is pulled low, pin Gx of the corresponding channel is no longer turned on. The MOSFET stays off and no current is delivered to the output of the corresponding channel.

8.7.1 Control for PWM pins

The ASL2416SHN provides the option to disable the PWM input for each of the two channels individually. In case the PWM input of one channel is disabled, this channel stays off, independent of any other conditions.

The bits to disable the PWM inputs are located in the function control register (refer to [Section 8.8](#) for details of the function control register).

8.7.2 Diagnostics for PWM functionality

The diagnostic options for the PWM functionality comprise the toggle information for the individual PWM pins. Details of the functionality can be found in [Section 8.8](#).

8.8 Function control register

To monitor the status of the SPI interface, use the function control register. It allows a reset of the fail silent mode and offers the control of the PWM inputs.

After enabling the device, the SPI_status bit should be set. When a query returns that the bit is set, the SPI interface is operational and the device can be configured. Configuration of the device is not permitted before this bit is set.

When the device enters fail silent mode due to an error condition, bit Clr_error can be set to bring the device back into operation mode. Once the error bits are cleared, the device clears the Clr_error bit automatically. If the Clr_error bit is set, when no error is present, the Clr_error bit remains set, until an error occurs. This error is cleared automatically.

The functionality of bits PWMctrl1 and PWMctrl2 is described in [Section 8.7.1](#).

Table 14. Function control register, address 0x00h

Bit	Symbol	Description	Value	Function
7	SPI_status	SPI status bit	0	SPI is not available
			1	SPI is operating
6	Clr_error	clear error bits	0	no pending clear request
			1	request to clear error bits and reset fail silent mode pending
5:3		reserved	0	reserved; keep clear for future use
2	PWMctrl2	PWM control for pin PWM2	0	PWM2 is disabled, channel stays off
			1	PWM2 is enabled, LED current depends on PWM state and Register settings
1	PWMctrl1	PWM control for pin PWM1	0	PWM1 is disabled, channel stays off
			1	PWM1 is enabled, LED current depends on PWM state and Register settings
0		reserved	0	reserved; keep clear for future use

8.9 Gate voltage supply

The ASL2416SHN has an integrated linear regulator to generate the supply voltage of the gate drivers. The voltage generated by the linear regulator can be set via the VGG control register.

Table 15. VGG control register, address 0x01h

Bit	Symbol	Description	Value	Function
7:0	VGG[7:0]	VGG control	0x00h	not allowed
			...	not allowed
			0x5Dh	maximum output voltage = 10.04 V
			...	$(255 - \text{VGG}[7:0]) * 62 \text{ mV}$
			0xA6h	minimum output voltage = 5.52 V
			...	not allowed
			0xFFh	not allowed

The actual value of VGG can deviate from the target setting due to the tolerances of the VGG regulation loop (see $V_{o(\text{reg})\text{acc}}$ in [Table 32](#)).

When a setting between 0x00h and 0x5Dh is used, the resulting gate driver target voltage exceeds the limiting values of the IC. The limiting values of the VGG pin can also be violated with target settings of 0xA6h to 0x5Dh due to these tolerances. A violation of the limiting values with the actual VGG voltage must be avoided. To ensure that only allowed settings are used for the gate driver target voltage, an immediate read back of the programmed value is required after setting the registers.

If a setting between 0xFFh and 0xA6h is used, the device may shut down.

8.9.1 Gate voltage supply diagnostics

The diagnostic options for the gate voltage supply are:

- VGG available. Details can be found in [Section 8.12](#)
- VGG overload protection active. Details can be found in [Section 8.12](#)

8.10 Junction temperature information

The ASL2416SHN provides a measurement of the IC junction temperature. The measurement information is available in the junction temperature register.

Table 16. Junction temperature register, address 0x26h

Bit	Symbol	Description	Value	Function
7:0	T_junction[7:0]	junction temperature	0xD8h	device junction temperature = $-40\text{ }^{\circ}\text{C}$
			...	device junction temperature = $(256 - T_{\text{junction}}[7:0])\text{ }^{\circ}\text{C}$
			0xFFh	device junction temperature = $-1\text{ }^{\circ}\text{C}$
			0x00h	device junction temperature = $0\text{ }^{\circ}\text{C}$
			0x01h	device junction temperature = $1\text{ }^{\circ}\text{C}$
			...	device junction temperature = $T_{\text{junction}}[7:0]^{\circ}\text{C}$
			0xAFh	device junction temperature = $175\text{ }^{\circ}\text{C}$

The reading of the junction temperature register should be in the range as given in [Table 16](#). If not, the Tj_err bit (Bit 5 in diagnostic register 1, address 0x37h) can be used to indicate whether the temperature is below $175\text{ }^{\circ}\text{C}$ (Tj_err = Low) or above $175\text{ }^{\circ}\text{C}$ (Tj_err = High).

8.11 Bootstrap recharge mechanism

The gate drivers and current delivered to the gate pins of the ASL2416SHN is supplied by the bootstrap capacitors. These capacitors are attached between the LXx and the BSx pins of the device. To allow a proper drive of the external FET, the voltage across this capacitor must remain near the target level of the gate drive voltage.

During device operation, if the external FET switches periodically at quite high frequency, the bootstrap capacitor is charged when the Lx node is low. It is the case when the external FET is off and the converter coil is delivering current to the output.

When the external FET is not switching periodically, the bootstrap capacitor is recharged regularly every t_p when:

- the PWM pin is low for more than $T_{\text{meas(LED)}}$
- the PWM is high and the CR0 bit is low

8.11.1 Bootstrap charge maintaining

To avoid a discharge of the bootstrap capacitors when the system is operated with long PWM off times and short PWM on times, an additional mechanism maintains the bootstrap charge.

The ASL2416SHN compensates for the current consumption of the IC on the BS pins. As a result, the BS cap no longer discharges, but slowly settles around VBS-LX.

The compensating mechanism is enabled when the gate driver is enabled, the PWM is low, and no Bootstrap undervoltage or low voltage headroom condition is detected.

8.12 Diagnostic information

Diagnostic registers contain useful information for diagnostic purposes. Details of each bit can be found in the following subchapters.

8.12.1 Diagnostic Register 1

The diagnostic register 1 contains information about the operational status of the ASL2416SHN.

Table 17. Diagnostic register 1, address 0x37h

Bit	Symbol	Description	Value	Function
7	VIN_stat	VIN status	0	VIN below under voltage detection threshold
			1	VIN above under voltage detection threshold
6	SPI_err	SPI error	0	last SPI command was executed correctly
			1	last SPI command was erroneous and has been discarded
5	Tj_err	device temperature is too high	0	device temperature below 175 °C
			1	device temperature above 175 °C
4	VGG_err	VGG error	0	VGG overload protection not active
			1	VGG overload protection has turned on and VGG is deactivated
3	VGG_ok	VGG regulation ok	0	VGG is not available
			1	VGG is available
2		reserved	0	reserved; keep clear for future use
1	I-CH2	target current reached on channel 2	0	target current was not reached during last PWM cycle
			1	target current was reached during last PWM cycle
0	I-CH1	target current reached on channel 1	0	target current was not reached during last PWM cycle
			1	target current was reached during last PWM cycle

8.12.1.1 Bit VIN_stat

The bit VIN_stat indicates the VIN voltage status of the device. This bit is set once the VIN voltage is higher than programmed under voltage threshold value. When VIN is less than the programmed under voltage threshold value, the bit is cleared. (see [Section 8.4](#) for details about the input under voltage detection functionality)

When the bit is high, the gate pins start switching. The device starts to deliver the output current as requested via the PWM inputs of the corresponding channels. The bits VGG_ok and VGG_err indicate the functional status of VGG.

When the bit is low, the VGG regulator and gate drivers are turned off. The gate pins stop switching, resulting in a turn-off of the output currents. The bit VGG_ok is reset, the bit VGG_err is not changed and the VLED measurement registers are no longer updated.

Table 18. Effect of VIN_stat on device functionality

Status of VIN	VIN_stat	VGG_ok	VGG_err	Output current	VLED measurement
below under voltage detection threshold	0	reset	cannot be set	disabled	no update
above under voltage detection threshold	1	no influence	no influence	enabled	updated when VGG_ok is 1

8.12.1.2 Bit SPI_err

The bit SPI_err indicates if some error has occurred during the last SPI transfer. When this bit is set after a write access to the device, the device discards the command. When the bit is set after a read command, the microcontroller should discard the information delivered by the device. The SPI_err bit is set in the following cases:

- SPI write is attempted to a read-only location or reserved location
- SPI read is attempted from a reserved location
- SPI command does not consist of a multiple of 16 clock counts

The SPI_err bit is cleared on a write to the diagnostic register 1.

In case a SPI_error has been detected, the device will return the diagnostic register 1 (default read) and diagnostic register 2 for the next SPI access.

8.12.1.3 Bit Tj_err

When the junction temperature rises above the maximum allowable temperature ($T_{sd(otp)}$), bit Tj_err is set high. It turns off the gate driver and the gate driver voltage regulator, and clears bit VGG_ok. If VGG_ok was already set high, bit VGG_err is set. The output current is no longer delivered. Only the SPI remains operational.

Bit Tj_err must only be cleared with the Clr_errors command when the junction temperature is below the maximum allowable temperature threshold again. Bit VGG_err, that is set together with bit Tj_err, is cleared together with bit Tj_err.

8.12.1.4 Bit VGG_err

The bit VGG_err is set when VGG cannot be regulated to its target value. During start-up, the device waits for $t_{err(startup)}$ until the bit is set, during normal operation the device waits only $t_{err(oper)}$. Once the bit is set, it turns off the gate driver and the gate driver voltage regulator, and clears bit VGG_ok. Consequently, output current can no longer be delivered. Only the SPI remains operational.

In case the VGG_err bit is set, the LED voltage measurement is no longer updated.

To reset the bit, the bit Clr_errors in the function control register can be set. Alternatively, the device must be set to off mode, e.g. by EN going low, or a power-on reset.

8.12.1.5 Bit VGG_ok

The bit VGG_ok is set, as soon as the VGG output is regulated to the target value. The bit is cleared on an under voltage condition at VIN, or an error on VGG.

8.12.1.6 Bit I-Ch1 and I-CH2

The bits I-CH1 and I-CH2 indicate, whether the targeted output current was reached or not in the last PWM cycle. Reasons for not reaching the target current can be e.g. an open LED string or a too low input voltage.

The bits are updated for a:

- falling edge of the PWM
- write of the CR copy pulse bit

The bits are cleared for a:

- VIN under voltage event
- low voltage headroom event on the representative channel

8.12.1.7 CR copy pulse

The bits CCH1 and CCH2 can be used to force an update of the LED current reached information. Setting a bit high, initiates an update of the I-CHx bit in the diagnostic register 1 and clears the CR0_CHx bit. The device automatically clears the bit that was set high after the update.

Table 19. CR copy pulse register, address 0x06h

Bit	Symbol	Description	Value	Function
7:2		reserved	000000	reserved; keep clear for future use
1	CCH2	update request for bit I-CH2	0	no pending update request
			1	update request for bit I-CH2
0	CCH1	update request for bit I-CH1	0	no pending update request
			1	update request for bit I-CH1

8.12.2 Diagnostic register 2

The diagnostic register 2 contains the PWM toggle information of the ASL2416SHN.

Table 20. Diagnostic register 2, address 0x36h

Bit	Symbol	Description	Value	Function
7		reserved	0	reserved; keep clear for future use
6		reserved	1	reserved; keep clear for future use
5:2		reserved	000	reserved; keep clear for future use
1	PWM2	toggle information for pin PWM2	0	PWM2 has not toggled since last time the register was read
			1	PWM2 has toggled since last time the register was read
0	PWM1	toggle information for pin PWM1	0	PWM1 has not toggled since last time the register was read
			1	PWM1 has toggled since last time the register was read

8.12.2.1 PWM toggle information (bits PWM1 and PWM2)

To allow the detection of errors in the control of the PWM pins, the ASL2416SHN allows some diagnostics of the PWM inputs via diagnostic register 2. This register contains the toggle information of the PWM inputs.

The bits are set when a change in the level of the pin is detected. The bits are reset on a write to diagnostic register 2.

8.12.3 Diagnostic register 3

Diagnostic register 3 contains the low voltage headroom warning information and the output current state bits.

8.12.3.1 Low voltage headroom warning

When the ASL2416SHN operates with low voltage headroom, it could lead to very high duty cycles. Subsequent long on-times for the external FET, could result in low switching frequencies. To avoid long on-times of the external FET, the supply voltage and output voltages are continuously monitored while the channel is on and VIN_stat is high. Once the output voltage is measured to be above VIN minus the low voltage headroom, the gate

pin is pulled low. It results in the FET being turned off. At the same moment in time, the low voltage headroom bit (LV_CHx in diagnostic register 3) for the corresponding channel is set.

If the voltage difference is again above the low voltage headroom, the device starts to operate again.

Bits LV_CH1 and LV_CH2 remain set until a write to the diagnostic register 3 is performed. If the bits are cleared while the channels are turned off or VIN_stat is low, the bits might be set again if the last sampled voltage indicates a low voltage headroom condition.

8.12.3.2 Output current state

Diagnostic register 3 also contains bits CR0_CH1 and CR0_CH2. The bits indicate the target current reached information of the individual channels for the current PWM cycle.

The bits are set as soon as the target current of the channel is reached.

The bits are cleared under the following conditions:

- a falling edge on the PWM pin
- a VIN under voltage event
- a CR0 copy pulse request via SPI
- the gate is driven high for more than 1 ms while PWM is high

8.12.3.3 Register content

Table 21. Diagnostic register 3, address 0x35h

Bit	Symbol	Description	Value	Function
7:5		reserved	00	reserved; keep clear for future use
4	CR0_CH2	current reached CH2	0	output current is not reached
			1	output current is reached
3	CR0_CH1	current reached CH1	0	output current is not reached
			1	output current is reached
2		reserved	00	reserved; keep clear for future use
1	LV_CH2	low voltage headroom in CH2	0	no low headroom event occurred
			1	at least one low headroom event occurred
0	LV_CH1	low voltage headroom in CH1	0	no low headroom event occurred
			1	at least one low headroom event occurred

8.12.4 Diagnostic register 4

Diagnostic register 4 contains the BS undervoltage detection bits.

8.12.4.1 Bootstrap undervoltage detection

The integrated bootstrap undervoltage detection monitors the voltage between the BS and the LX pins during the off time of the LX pin. If the voltage drops below VBS_UV, the ASL2416SHN prevents the gate from being turned-on and prevent the MOSFET being driven at a low voltage.

When this condition is detected on a channel, the channel is turned off and the appropriate error bit is set. A write command to the device clears the error bit and any bits to be cleared are set high. Once the error is cleared, the channel is enabled again.

Table 22. BS_UV register - read access, address 0x34h

Bit	Symbol	Description	Value	Function
7:2		reserved	00000	reserved; keep clear for future use
1	BS_UV2	low BS warning CH2	0	no low BS event occurred
			1	at least one low BS event occurred
0	BS_UV1	low BS warning CH1	0	no low BS event occurred
			1	at least one low BS event occurred

Table 23. BS_UV register - write access, address 0x34h

Bit	Symbol	Description	Value	Function
7:2		reserved	00000	reserved; keep clear for future use
1	BS_UV2	low BS warning CH2	0	no action
			1	clear low BS warning for channel 2
0	BS_UV1	low BS warning CH1	0	no action
			1	clear low BS warning for channel 1

8.13 SPI

The ASL2416SHN uses an SPI interface to communicate with an external microcontroller. The SPI interface can be used for setting the LEDs current, reading and writing the control register.

8.13.1 Introduction

The Serial Peripheral Interface (SPI) provides the communication link with the microcontroller, supporting multi-slave operations. The SPI is configured for full duplex data transfer, so status information is returned when new control data is shifted in. The interface also offers a read-only access option, allowing the application to read back the registers without changing the register content.

The SPI uses four interface signals for synchronization and data transfer:

- CSB - SPI chip select; active LOW
- SCLK - SPI clock - default level is LOW due to low-power concept
- SDI - SPI data input
- SDO - SPI data output - floating when pin CSB is HIGH

Bit sampling is performed on the falling clock edge and data is shifted on the rising clock edge as illustrated in [Figure 4](#).

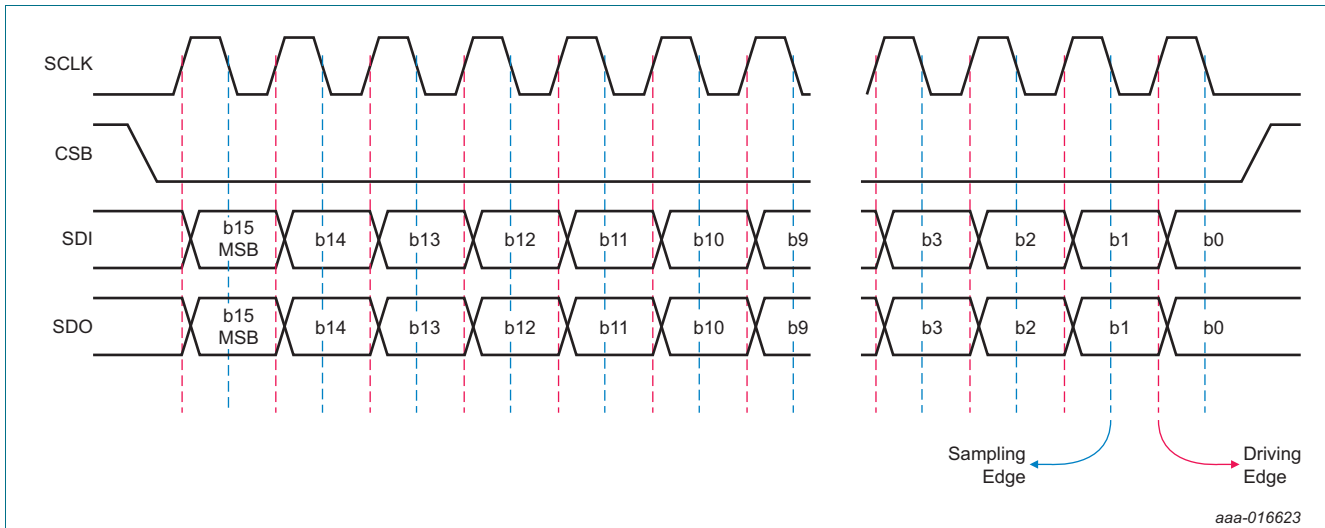

Fig 4. SPI timing protocol

The data bits of the ASL2416SHN are arranged in registers of 1 byte length. Each register is assigned to a 7-bit address. For writing into a register, 2 bytes must be sent to the LED driver. The first byte is an identifier byte that consists of the 7-bit address and one read-only bit. For writing, the read-only bit must be set to “0”. The second byte is the data that is written into the register. So an SPI access consists of at least 16 bits.

Figure 5 together with Table 24 and Table 25 demonstrate the SPI frame format.

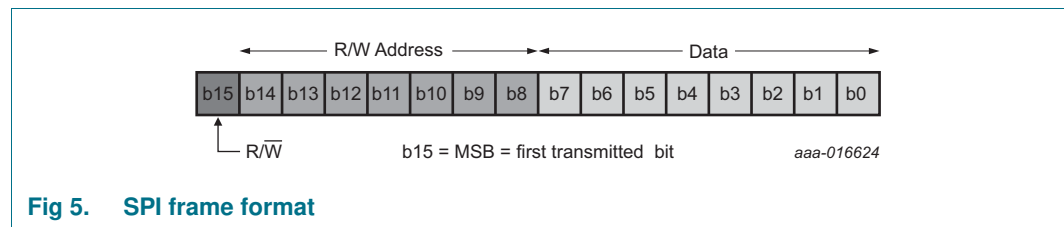

Fig 5. SPI frame format

Table 24. SPI frame format for a transition to the device

Bit	Symbol	Description	Value	Function
15	b15	R/W bits	0	write access
			1	read access
14:8	b14:8	address bits	...	selected address
7:0	b7:0	data bits	...	transmitted data

Table 25. SPI frame format for a transition from the device

Bit	Symbol	Description	Value	Function
15:8	b15:8	diagnostic register 1	...	content of diagnostic register 1
7:0	b7:0	data bits	...	when previous command was a valid read command, content of the register that is supposed to be read
			...	When previous command was a valid write command, new content of the register that was supposed to be written

Note: The first SPI command after a leaving of off mode returns 0x00h.

The Master initiates the command sequence. The sequence begins with CSB pin pulled low and lasts until it is asserted high.

The ASL2416SHN also tolerates SPI accesses with a multiple of 16 bits. It allows a daisy chain configuration of the SPI.

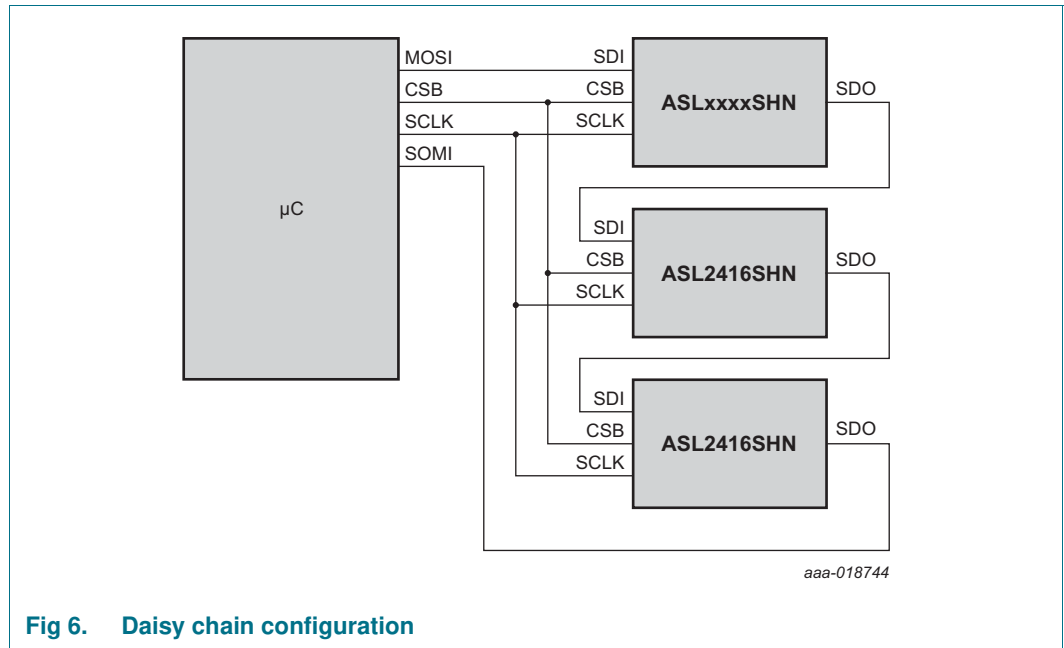

Fig 6. Daisy chain configuration

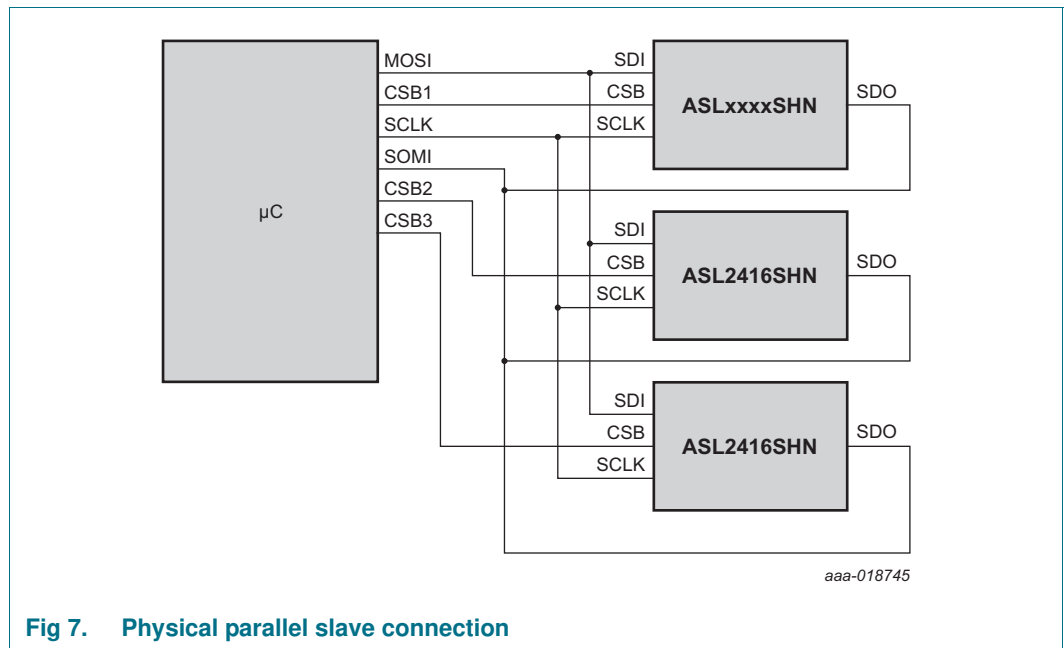

Fig 7. Physical parallel slave connection

During the SPI data transfer, the identifier byte and the actual content of the addressed registers is returned via the SDO pin. The same happens for pure read accesses. Here the read-only bit must be set to 1. The content of the data bytes that are transmitted to the ASL2416SHN is ignored.

The ASL2416SHN monitors the number of data bits that are transmitted. If the number is not 16, or a multiple of 16, then a write access is ignored and the SPI error indication bit is set.

8.13.2 Typical use case illustration (write/read)

Consider a daisy chain scheme with one master connected to 4 slaves in Daisy chain fashion. The following commands are performed during one sequence (first sequence).

- write data 0xFF to register 0x1A slave 1
- read from register 0x02 of slave 2
- write data 0xAF to register 0x2F of slave 3
- read from register 0x44 of slave 4

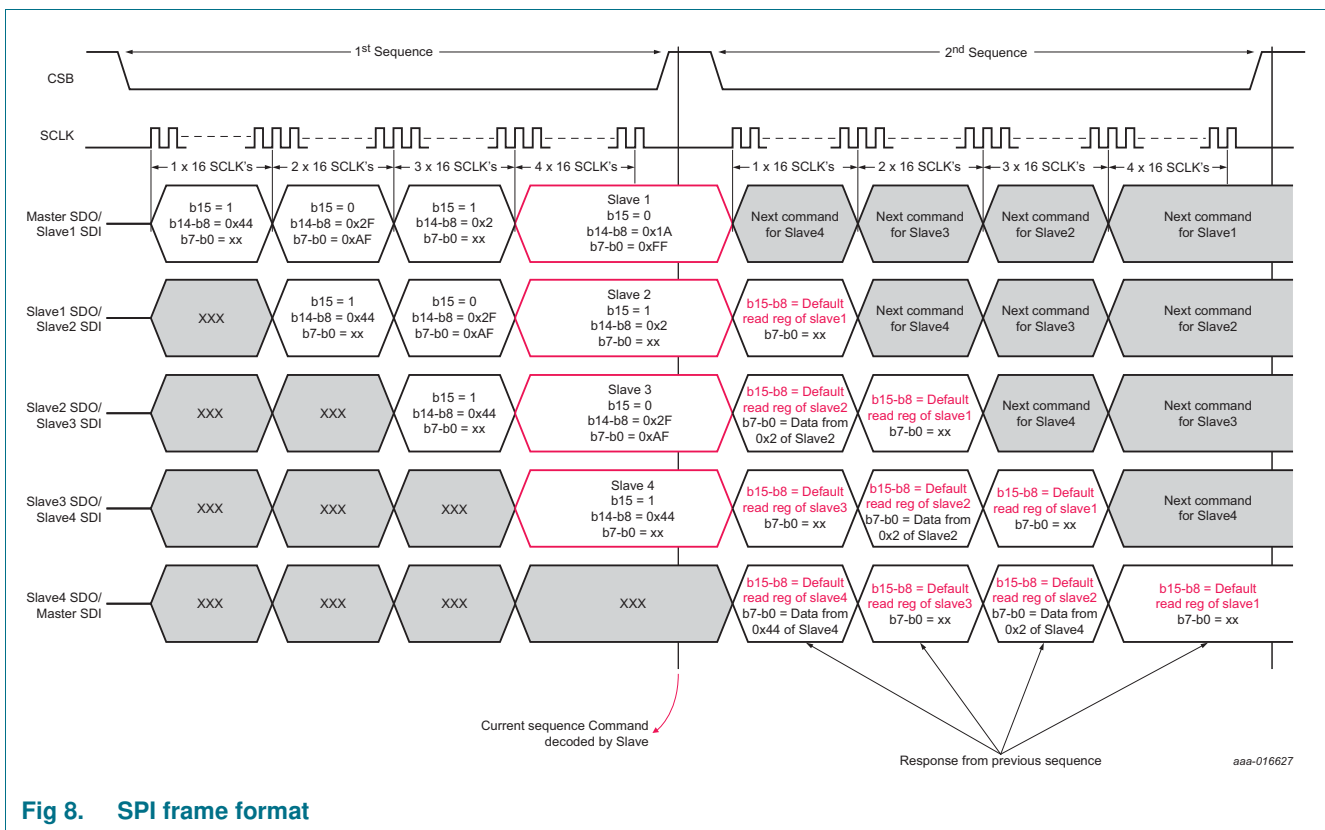

Fig 8. SPI frame format

8.13.3 Diagnostics for the SPI interface

The diagnostic options for the SPI interface are Error during last SPI transfer. For details, refer to [Section 8.11](#).

8.13.4 Register map

The addressable register space amounts to 128 registers from 0x00 to 0x7F. They are separated in two groups as shown in [Table 26](#). The register mapping is shown in [Table 27](#) and [Table 28](#). The functional description of each bit can be found in the dedicated chapter.

Table 26. Grouping of the register space

Address range	Description	Content
0x00 ... 0x1F	control registers	thresholds, LED currents
0x20 ... 0x7F	diagnostic registers	LED voltages, PWM toggle information

8.13.4.1 Control registers

[Table 27](#) provides an overview of the control registers and their reset state.

Table 27. Control register group overview

Address	Name	Reset value	7	6	5	4	3	2	1	0
0x00h	function control	0x0Eh	SPI_status	Clr_errors	-	-	-	PWMctrl2	PWMctrl1	-
0x01h	VGG control	0xFFh	VGG[7:0]							
0x02h	LED current channel 1	0x00h	I_LED_CH1[7:0]							
0x03h	LED current channel 2	0x00h	I_LED_CH2[7:0]							
0x05h	LED current range	0x07h	-	-	-	-	-	-	I_CH2	I_CH1
0x06h	CR copy pulse	0x00h	-	-	-	-	-	-	CCH2	CCH1
0x0Bh	hysteresis channel 1	0x03h	-	-	-	-	-	-	HCH1[1:0]	
0x0Ch	hysteresis channel 2	0x03h	-	-	-	-	-	-	HCH2[1:0]	
0x0Fh	undervoltage threshold	0x00h	V_VIN_UV[7:0]							

8.13.4.2 Diagnostic registers

[Table 28](#) provides an overview of the diagnostic registers. As the device continuously updates these registers, they do not have a default value.

Table 28. Diagnostic register group overview

Address	Name	7	6	5	4	3	2	1	0	
0x20h	LED on voltage channel 1	V_LED1_on[7:0]								
0x21h	LED off voltage channel 1	V_LED1_off[7:0]								
0x22h	LED on voltage channel 2	V_LED2_on[7:0]								
0x23h	LED off voltage channel 2	V_LED2_off[7:0]								
0x26h	junction temperature	T_junction[7:0]								
0x34h	diagnostic register 4	-	-	-	-	-	-	BS_UV2	BS_UV1	
0x35h	diagnostic register 3	-	-	-	CR0_CH2	CR0_CH1	-	LV_CH2	LV_CH1	
0x36h	diagnostic register 2	-	1	-	-	-	-	PWM2	PWM1	
0x37h	diagnostic register 1 (default read register)	VIN_Stat	SPI_er	Tj_er	VGG_er	VGG_ok	-	I-CH2	I-CH1	
0x38h	VIN voltage measurement ^[1]	V_VIN[7:0]								

[1] A write to the VIN voltage measurement register does not set the SPI error bit high.

8.13.4.3 Internal registers

The ASL2416SHN uses the SPI registers to control some internal functions. In order to avoid any unintended behavior of the device, do not modify these registers but leave them all at their default value.

Table 29. Internal register overview

Address	Name	Default value	7	6	5	4	3	2	1	0
0x04h	Internal 1	0x16h	-	-	-	-	-	-	-	-
0x0Dh	Internal 2	0x03h	-	-	-	-	-	-	-	-
0x24h	Internal 3	0x00h	-	-	-	-	-	-	-	-
0x25h	Internal 4	0x00h	-	-	-	-	-	-	-	-

9. Limiting values

Table 30. Limiting values

In accordance with the Absolute Maximum Rating System (IEC 60134).

Symbol	Parameter	Conditions	Min	Max	Unit
V _{IN}	voltage on pin VIN	EN = low	-0.3	+80	V
		EN = high	10	80	V
V _{VCC}	voltage on pin VCC		-0.3	+5.5	V
V _{I(dig)}	digital input voltage	voltage on pins SDO, SDI, CSB, SCLK, EN, PWM1 and PWM2	-0.3	+5.5	V
V _{VGG}	voltage on pin VGG		-0.3	+10	V
V _{LX}	voltage on pin LX	LX1 and LX2	-1.0	+80	V
SR _{f(max)}	maximum falling edge slew rate	on pins LX1, LX2 and LX3; at maximum input voltage	-	5.0 ^[1]	V/ns
V _{sense}	sense voltage	voltage on sense pins RH1, RL1, RH2, RL2, RH3 and RL3	-1.0	+70 ^[2]	V
ΔV _{RH-RL(max)}	maximum voltage drop between pins RH and RL	maximum drop between the RH and RL pins of one channel	-0.3	+0.8	V
V _{BSx}	voltage on bootstrap pins	BS1 and BS2	-0.3	+90	V
V _{Gx}	voltage on gate pins	G1 and G2	-1.0	+90	V
ΔV _{max}	maximum voltage difference	between pins G and LX of one channel	-	12	V
		between pins BS and LX of one channel	-	12	V
T _j	junction temperature		-40	+175	°C
T _{stg}	storage temperature		-55	+175	°C
V _{ESD}	electrostatic discharge voltage	HBM ^[3]			
		at any pin	-2	+2	kV
		at pins RLx with respect to GND and 100 nF at pin	-6	+6	kV
		CDM ^[4]			
	at any pin	-500	+500	V	

[1] The limitation of the slew rate is an IC constraint. When the IC is operating in an application circuit, the external circuitry influences the slew rate capability. An example guideline for some specific MOSFET parameters to be considered when selecting the appropriate resistor values, can be found in the table below. Nonetheless, each application should be validated to determine the final solution when considering EMC performance and correct gate driver operation.

[2] 76 V for t ≤ 10 seconds guaranteed by design.

[3] Human Body Model (HBM): according to AEC-Q100-002 (100 pF, 1.5 kΩ).

[4] Charged Device Model (CDM): according to AEC-Q100-011 (field induced charge; 4 pF).

9.1 External circuitry

Table 31. Guideline for external circuitry

Symbol	Component	MOSFET configuration typical values			Unit
		Config. 1	Config. 2	Config. 3	
R _G	[1]	1.0	4.7	1.7	Ω
Q _{GS}	[1]	0.6	1.2	0.8	nC
Q _{GD}	[1]	0.9	1.8	1.2	nC
R _{DSon}	[1]	175	80	72	mΩ
R _{gate}	gate resistor	33	15	33	Ω
RL _x	sense resistor low side channel	10	10	10	Ω
C5		1	1	1	μF

[1] MOSFET M5

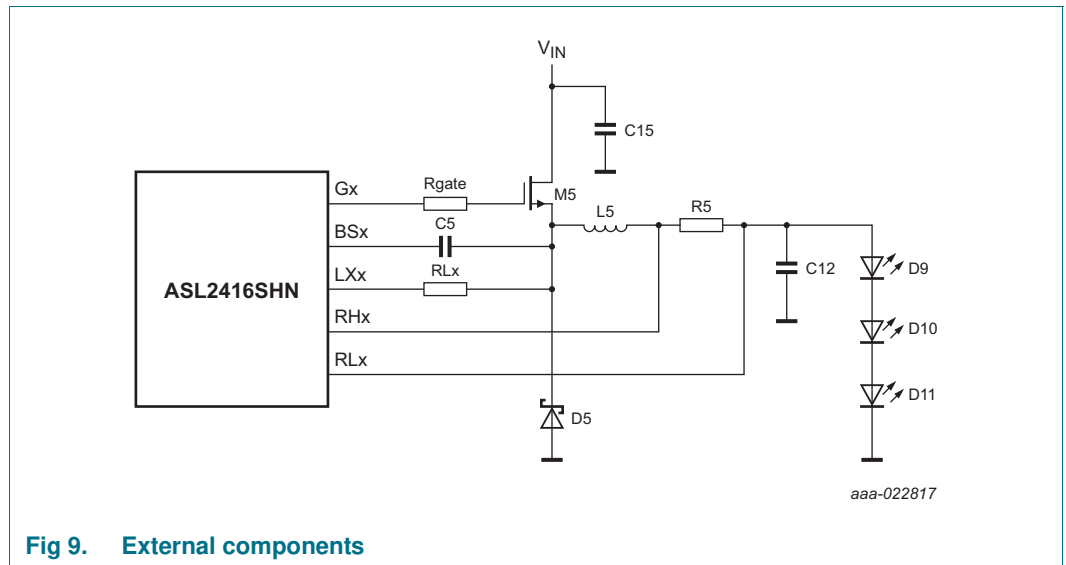

Fig 9. External components