



Chipsmall Limited consists of a professional team with an average of over 10 year of expertise in the distribution of electronic components. Based in Hongkong, we have already established firm and mutual-benefit business relationships with customers from,Europe,America and south Asia,supplying obsolete and hard-to-find components to meet their specific needs.

With the principle of “Quality Parts,Customers Priority,Honest Operation,and Considerate Service”,our business mainly focus on the distribution of electronic components. Line cards we deal with include Microchip,ALPS,ROHM,Xilinx,Pulse,ON,Everlight and Freescale. Main products comprise IC,Modules,Potentiometer,IC Socket,Relay,Connector.Our parts cover such applications as commercial,industrial, and automotives areas.

We are looking forward to setting up business relationship with you and hope to provide you with the best service and solution. Let us make a better world for our industry!



## Contact us

Tel: +86-755-8981 8866 Fax: +86-755-8427 6832

Email & Skype: info@chipsmall.com Web: www.chipsmall.com

Address: A1208, Overseas Decoration Building, #122 Zhenhua RD., Futian, Shenzhen, China



# Data Sheet

## SM01Y01VXNN0G1 15-inch reel solder pad/solder side

### Illustration

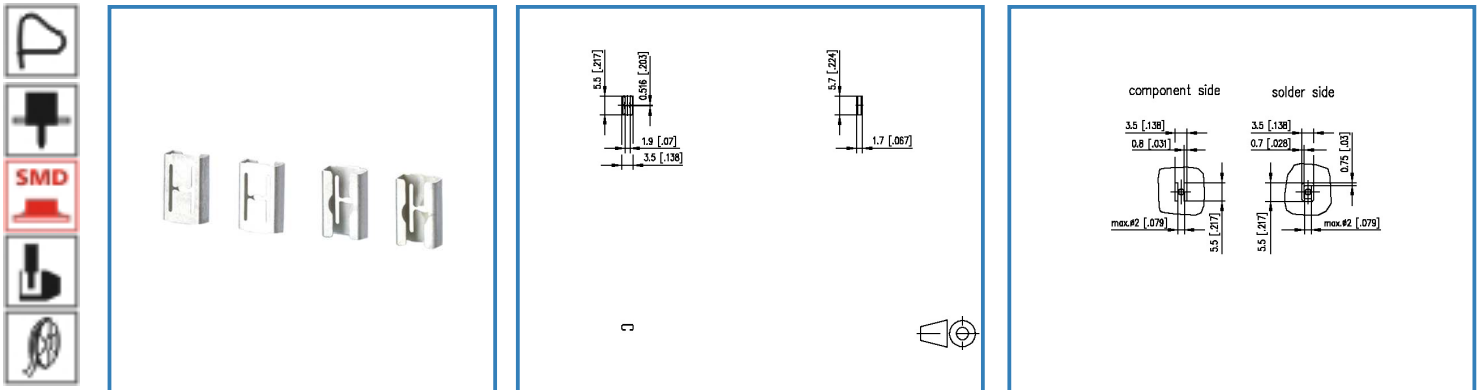

see enlarged drawing at the end of the document

### Product specification

- spring clamp terminal block, SMT solderable
- direction of connection vertical 0°
- Tape & Reel packaging

© 2017 METZ CONNECT - Technische Änderungen vorbehalten! Subject to modifications! Sous réserve de modifications techniques!



# Data Sheet

## SM01Y01VXNN0G1 15-inch reel solder pad/solder side

### Technical Data

#### General Data

min. number of poles	1
max. number of poles	1
protection category	IP 00
Min. insul. strip length	4 mm

#### Connection data

Rated wiring solid wire	0.75 - 1.5 mm <sup>2</sup> / AWG 18 - 16
-------------------------	--

#### Approvals

0.75 - 1.5 mm <sup>2</sup>	AWG 18 - 16 / 13 A
----------------------------	--------------------

#### Material

contact material	CuBe
contact surface	Ni + Sn

#### General

solderability	Acc. to IPC/JEDEC J-STD-020D-MSL 1
Tolerance	ISO 2768 -mH

#### Safety instructions

Components have to be fixed in a way to prevent any transmission of forces on to the contact. Components with more than one pin are recommended.



# Data Sheet

## SM01Y01VXNN0G1 15-inch reel solder pad/solder side

Page 3/6

P/N

ASM01Y0164-0G16

2017/05/05

### Matching Part

P/N	Product name
709023 (on request)	Tape_ASM01Y_16mm

### Matching Part to

P/N	Product name
709023 (on request)	Tape_ASM01Y_16mm

© 2017 METZ CONNECT - Technische Änderungen vorbehalten! Subject to modifications! Sous réserve de modifications techniques!



# Data Sheet

## SM01Y01VXNN0G1 15-inch reel solder pad/solder side

### Illustration

Drawing

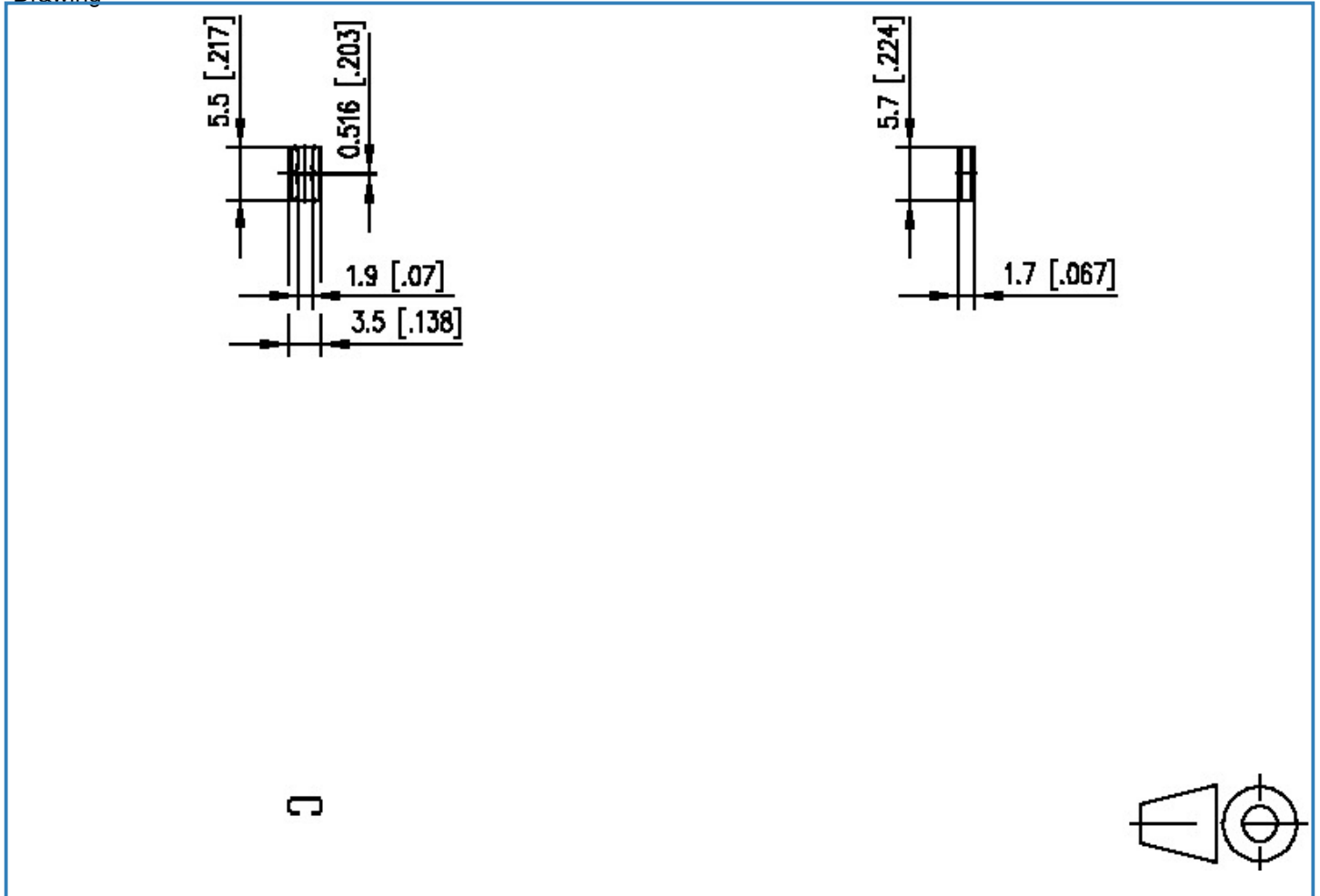

© 2017 METZ CONNECT - Technische Änderungen vorbehalten! Subject to modifications! Sous réserve de modifications techniques!



# Data Sheet

## SM01Y01VXNN0G1 15-inch reel solder pad/solder side

### PCB Layout

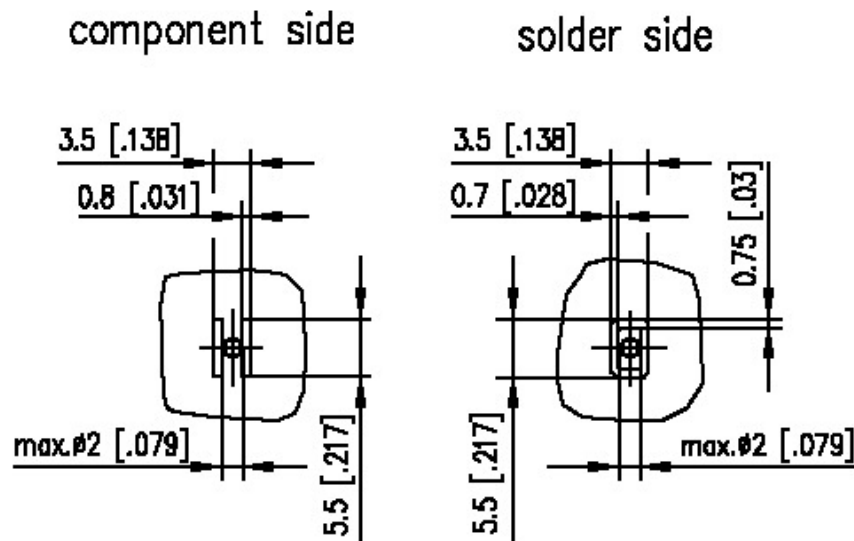

# Data Sheet

## SM01Y01VXNN0G1 15-inch reel solder pad/solder side

Page 6/6

P/N

ASM01Y0164-0G16

2017/05/05

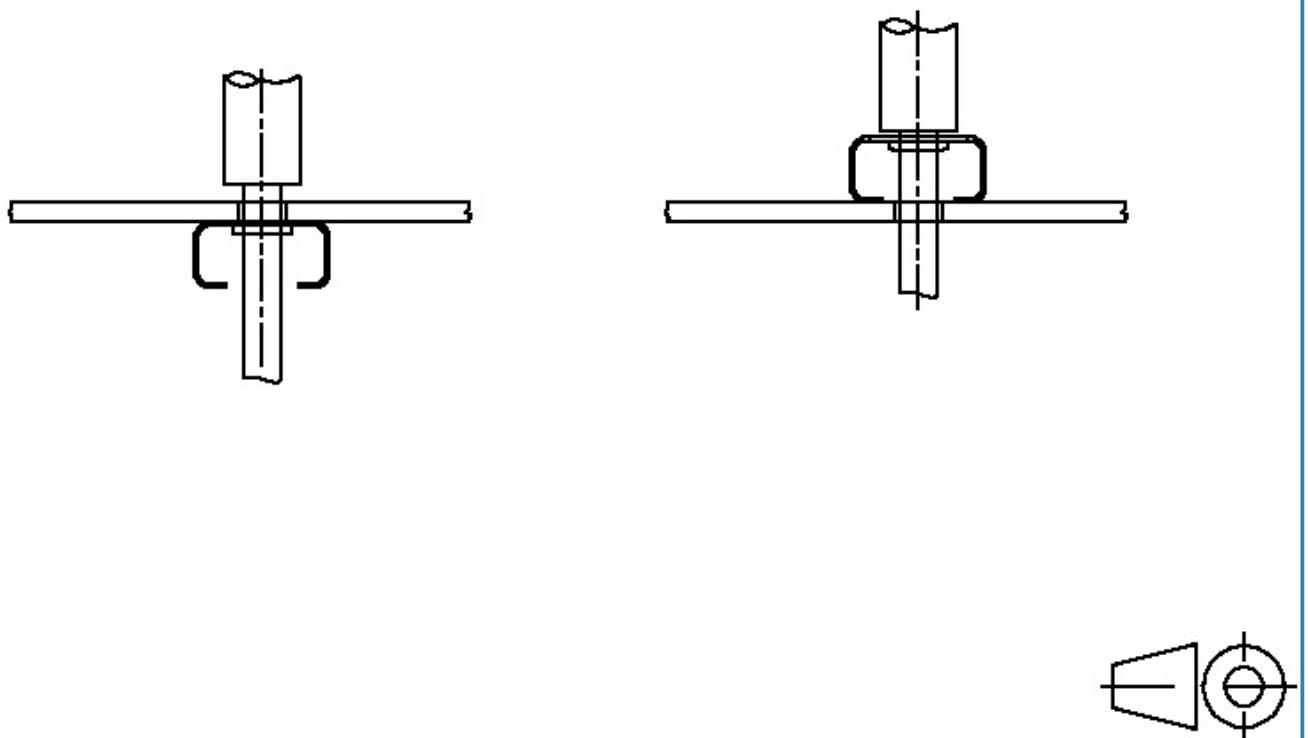

© 2017 METZ CONNECT - Technische Änderungen vorbehalten! Subject to modifications! Sous réserve de modifications techniques!

