



Chipsmall Limited consists of a professional team with an average of over 10 year of expertise in the distribution of electronic components. Based in Hongkong, we have already established firm and mutual-benefit business relationships with customers from,Europe,America and south Asia,supplying obsolete and hard-to-find components to meet their specific needs.

With the principle of “Quality Parts,Customers Priority,Honest Operation,and Considerate Service”,our business mainly focus on the distribution of electronic components. Line cards we deal with include Microchip,ALPS,ROHM,Xilinx,Pulse,ON,Everlight and Freescale. Main products comprise IC,Modules,Potentiometer,IC Socket,Relay,Connector.Our parts cover such applications as commercial,industrial, and automotives areas.

We are looking forward to setting up business relationship with you and hope to provide you with the best service and solution. Let us make a better world for our industry!



Contact us

Tel: +86-755-8981 8866 Fax: +86-755-8427 6832

Email & Skype: info@chipsmall.com Web: www.chipsmall.com

Address: A1208, Overseas Decoration Building, #122 Zhenhua RD., Futian, Shenzhen, China





Peak EMI Reducing Solution

Features

- Generates an EMI optimized clock at the output.
- Input frequency: 25MHz.
- Frequency outputs:
 - 60MHz (unmodulated)
 - 2 x 48MHz (unmodulated)
 - 66.6MHz (modulated): -1.7% down spread
- Modulation rate: 30KHz.
- Supply voltage range: $3.3V \pm 0.3V$.
- Available in 8-pin SOIC Package.
- RoHS Compliant

Product Description

The ASM3P2111B is a versatile spread spectrum frequency modulator that reduces electromagnetic interference (EMI) at the clock source. The ASM3P2111B allows significant system cost savings by reducing the

number of circuit board layers and shielding that are required to pass EMI regulations. The ASM3P2111B modulates the output of PLL in order to spread the bandwidth of a synthesized clock, thereby decreasing the peak amplitudes of its harmonics. This results in significantly lower system EMI compared to the typical narrow band signal produced by oscillators and most clock generators. Lowering EMI by increasing a signal's bandwidth is called spread spectrum clock generation.

Applications

ASM3P2111B is targeted towards EMI management for high speed digital applications such as PC peripheral devices, consumer electronics and embedded controller systems.

Block Diagram

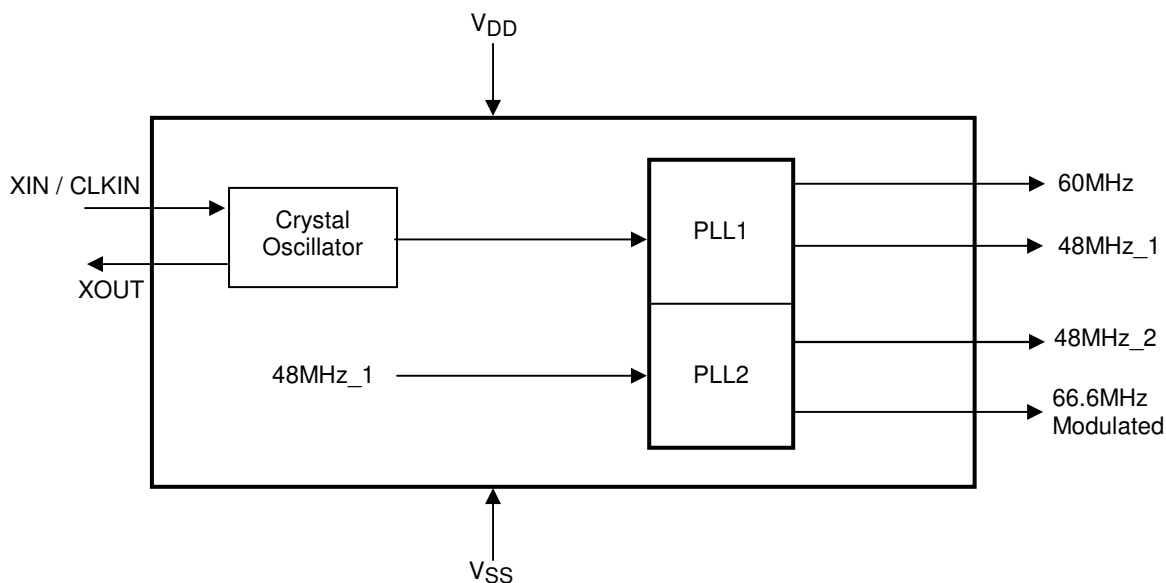

Pin Configuration

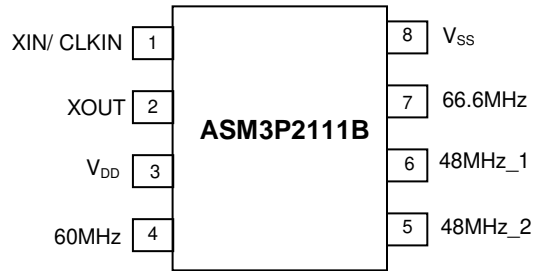

Pin Description

Pin #	Pin Name	Type	Description
1	XIN / CLKIN	I	Connection to crystal
2	XOUT	O	Connection to crystal
3	V _{DD}	P	Power supply for the analog and digital blocks (+3.3V)
4	60MHz	O	Clock output-1 60MHz un-modulated
5	48MHz_2	O	Clock output-2 48MHz_2 un-modulated
6	48MHz_1	O	Clock output-3 48MHz_1 un-modulated
7	66.6MHz	O	Clock output-4 66.6MHz modulated
8	V _{SS}	P	Ground to entire chip. Connect to System Ground

Absolute Maximum Ratings

Symbol	Parameter	Rating	Unit
V_{DD}, V_{IN}	Voltage on any pin with respect to Ground	-0.5 to +4.6	V
T_{STG}	Storage temperature	-65 to +125	°C
T_s	Max. Soldering Temperature (10 sec)	260	°C
T_J	Junction Temperature	150	°C
T_{DV}	Static Discharge Voltage (As per JEDEC STD22- A114-B)	2	KV

Note: These are stress ratings only and are not implied for functional use. Exposure to absolute maximum ratings for prolonged periods of time may affect device reliability.

Operating Conditions

Symbol	Parameter	Min	Typ	Max	Unit
V_{DD}	Supply Voltage	3	3.3	3.6	V
F_{XIN}	Crystal Resonator Frequency		25		MHz
T_A	Operating Temperature	-40		+85	°C
C_L	Output Driver Load Capacitance			15	pF

DC Electrical Characteristics

Parameter	Symbol	Conditions / Description	Min	Typ	Max	Unit
Overall						
Supply Current, Dynamic	I_{DD}	$V_{DD} = 3.3V, F_{CLK} = 25MHz, C_L = 15pF$	41	48	62	mA
Supply Current, Static	I_{DDL}	$V_{DD} = 3.3V, \text{Clock Input} = 0$	20	25	35	mA
All input pins						
High-Level Input Voltage	V_{IH}	$V_{DD} = 3.3V$	2.0		$V_{DD}+0.3$	V
Low-Level Input Voltage	V_{IL}	$V_{DD} = 3.3V$	$V_{SS}-0.3$		0.8	V
High-Level Input Current	I_{IH}		-1		1	μA
Low-Level Input Current (pull-up)	I_{IL}		-20	-36	-80	μA
High-Level Output Source Current	I_{xOH}	$V_{DD} = V(XIN) = 3.3V, V_O = 0.4V$		3		mA
Low-Level Output Sink Current	I_{xOL}	$V_{DD} = 3.3V, V(XIN) = V_O = 2.5V$		3		mA
Clock Outputs						
High-Level Output Source Current	I_{OH}	$V_O = 2.5V$		-20		mA
Low-Level Output Sink Current	I_{OL}	$V_O = 0.4V$		23		mA
Output Impedance	Z_{OH}	$V_O = 0.5 V_{DD}; \text{output driving high}$		29		Ω
	Z_{OL}	$V_O = 0.5 V_{DD}; \text{output driving low}$		27		

AC Electrical Characteristics

Parameter	Symbol	Conditions / Description	Min	Typ	Max	Unit
Rise Time	t_r	$V_O = 0.8V \text{ to } 2.0V;$ $C_L = 15pF$	300	800	900	pS
Fall Time	t_f	$V_O = 2.0V \text{ to } 0.8V;$ $C_L = 15pF$	360	800	900	pS
Clock Duty Cycle		Ratio of pulse width (as measured from rising edge to next falling edge at $V_{DD}/2$) to one clock period	45		55	%
Note: 1. $C_L = 15pF$, Input clock frequency = 25MHz.						

Typical Crystal Specifications

Fundamental AT cut parallel resonant crystal	
Nominal frequency	25MHz
Frequency tolerance	± 50 ppm or better at 25°C
Operating temperature range	-25°C to +85°C
Storage temperature	-40°C to +85°C
Load capacitance(C_P)	18pF
Shunt capacitance	7pF maximum
ESR	25 Ω

Note: Note: C_L is Load Capacitance and R_x is used to prevent oscillations at overtone frequency of the Fundamental frequency.

Typical Crystal Interface Circuit

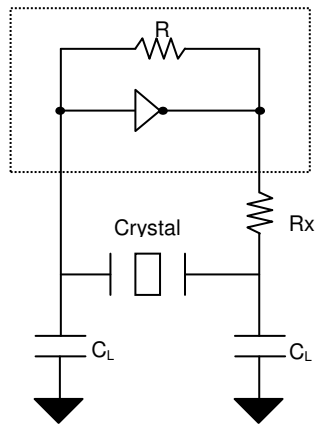

$$C_L = 2 * (C_P - C_S),$$

Where C_P = Load capacitance of crystal

C_S = Stray capacitance due to C_{IN} , PCB, Trace etc.

Package Information

8-lead (150-mil) SOIC Package

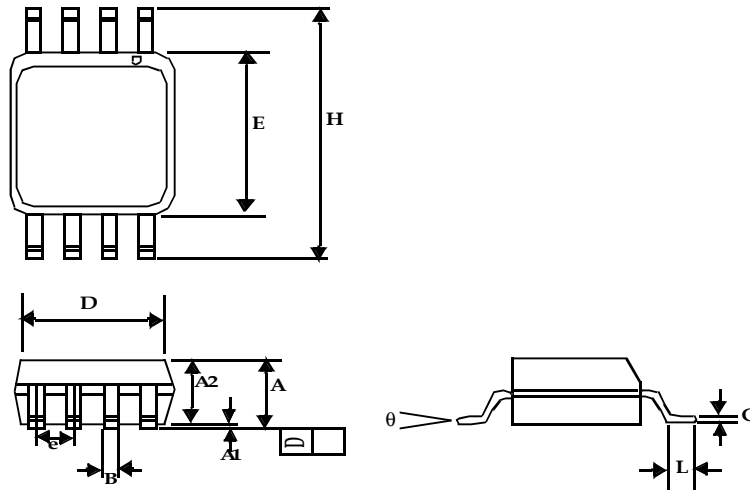

Symbol	Dimensions			
	Inches		Millimeters	
	Min	Max	Min	Max
A1	0.004	0.010	0.10	0.25
A	0.053	0.069	1.35	1.75
A2	0.049	0.059	1.25	1.50
B	0.012	0.020	0.31	0.51
C	0.007	0.010	0.18	0.25
D	0.193 BSC		4.90 BSC	
E	0.154 BSC		3.91 BSC	
e	0.050 BSC		1.27 BSC	
H	0.236 BSC		6.00 BSC	
L	0.016	0.050	0.41	1.27
θ	0°	8°	0°	8°

ASM3P2111B

Ordering Codes

Part number	Marking	Package Configuration	Temperature Range
ASM3P2111BG-08SR	AEI	8-pin SOIC TAPE & REEL, Green	0°C to +70°C

A "microdot" placed at the end of last row of marking or just below the last row toward the center of package indicates Pb-free

Licensed under US patent #5,488,627, #6,646,463 and #5,631,920.

Note: This product utilizes US Patent #6,646,463 Impedance Emulator Patent issued to PulseCore Semiconductor, dated 11-11-2003.

ON Semiconductor and  are registered trademarks of Semiconductor Components Industries, LLC (SCILLC). SCILLC reserves the right to make changes without further notice to any products herein. SCILLC makes no warranty, representation or guarantee regarding the suitability of its products for any particular purpose, nor does SCILLC assume any liability arising out of the application or use of any product or circuit, and specifically disclaims any and all liability, including without limitation special, consequential or incidental damages. "Typical" parameters which may be provided in SCILLC data sheets and/or specifications can and do vary in different applications and actual performance may vary over time. All operating parameters, including "Typicals" must be validated for each customer application by customer's technical experts. SCILLC does not convey any license under its patent rights nor the rights of others. SCILLC products are not designed, intended, or authorized for use as components in systems intended for surgical implant into the body, or other applications intended to support or sustain life, or for any other application in which the failure of the SCILLC product could create a situation where personal injury or death may occur. Should Buyer purchase or use SCILLC products for any such unintended or unauthorized application, Buyer shall indemnify and hold SCILLC and its officers, employees, subsidiaries, affiliates, and distributors harmless against all claims, costs, damages, and expenses, and reasonable attorney fees arising out of, directly or indirectly, any claim of personal injury or death associated with such unintended or unauthorized use, even if such claim alleges that SCILLC was negligent regarding the design or manufacture of the part. SCILLC is an Equal Opportunity/Affirmative Action Employer. U.S. Patent Pending; Timing-Safe and Active Bead are trademarks of PulseCore Semiconductor, a wholly owned subsidiary of ON Semiconductor. This literature is subject to all applicable copyright laws and is not for resale in any manner.

PUBLICATION ORDERING INFORMATION

LITERATURE FULFILLMENT:

Literature Distribution Center for ON Semiconductor
P.O. Box 5163, Denver, Colorado 80217 USA
Phone: 303-675-2175 or 800-344-3860 Toll Free
USA/Canada
Fax: 303-675-2176 or 800-344-3867 Toll Free
USA/Canada
Email: orderlit@onsemi.com

N. American Technical Support: 800-282-9855
Toll Free USA/Canada
Europe, Middle East and Africa Technical Support:
Phone: 421 33 790 2910
Japan Customer Focus Center
Phone: 81-3-5773-3850

ON Semiconductor Website:
www.onsemi.com

Order Literature: <http://www.onsemi.com/orderlit>

For additional information, please contact your local Sales Representative