



Chipsmall Limited consists of a professional team with an average of over 10 year of expertise in the distribution of electronic components. Based in Hongkong, we have already established firm and mutual-benefit business relationships with customers from,Europe,America and south Asia,supplying obsolete and hard-to-find components to meet their specific needs.

With the principle of “Quality Parts,Customers Priority,Honest Operation,and Considerate Service”,our business mainly focus on the distribution of electronic components. Line cards we deal with include Microchip,ALPS,ROHM,Xilinx,Pulse,ON,Everlight and Freescale. Main products comprise IC,Modules,Potentiometer,IC Socket,Relay,Connector.Our parts cover such applications as commercial,industrial, and automotives areas.

We are looking forward to setting up business relationship with you and hope to provide you with the best service and solution. Let us make a better world for our industry!



## Contact us

Tel: +86-755-8981 8866 Fax: +86-755-8427 6832

Email & Skype: info@chipsmall.com Web: www.chipsmall.com

Address: A1208, Overseas Decoration Building, #122 Zhenhua RD., Futian, Shenzhen, China



# ASMT-Mx22 / ASMT-MxE2

## Moonstone 3 W High Brightness Power LED Light Source



### Data Sheet



#### Description

The Moonstone 3W High Brightness Power LED Light Source is a high performance energy efficient device which can handle high thermal and high driving current. The exposed pad design has excellent heat transfer from the package to the motherboard.

The Cool White Power LED is available in various color temperature ranging from 4000 K to 10000 K and Warm White Power LED ranging from 2600 K to 4000 K.

The low profile package design is suitable for a wide variety of applications especially where height is a constraint.

The package is compatible with reflow soldering. This will give more freedom and flexibility to the light source designer.

#### Applications

- Sign backlight
- Safety, exit and emergency sign lightings
- Specialty lighting such as task lighting and reading lights
- Retail display
- Commercial lighting
- Accent or marker lightings, strip or step lightings
- Portable lightings, bicycle head lamp, torch lights.
- Decorative lighting
- Architectural lighting
- Pathway lighting
- Street lighting
- Pedestrian street lighting
- Tunnel lighting

#### Features

- Available in Cool White & Warm White color
- Energy efficient
- Exposed pad for excellent heat transfer
- Suitable for reflow soldering process
- High current operation
- Long operation life
- Wide viewing angle
- Silicone encapsulation
- Non-ESD sensitive (threshold > 16 kV)
- MSL 4 products

#### Specifications

- InGaN Technology
- 3.5 V (max) at 350 mA
- 110° viewing angle

## Package Dimensions

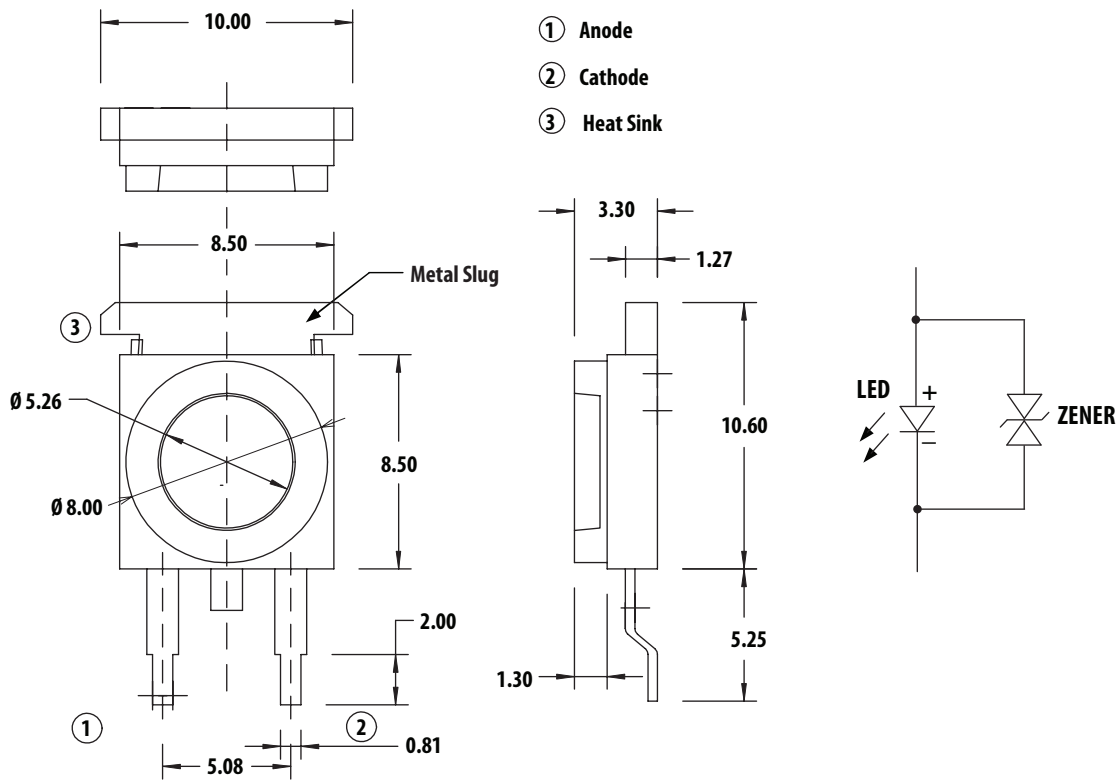
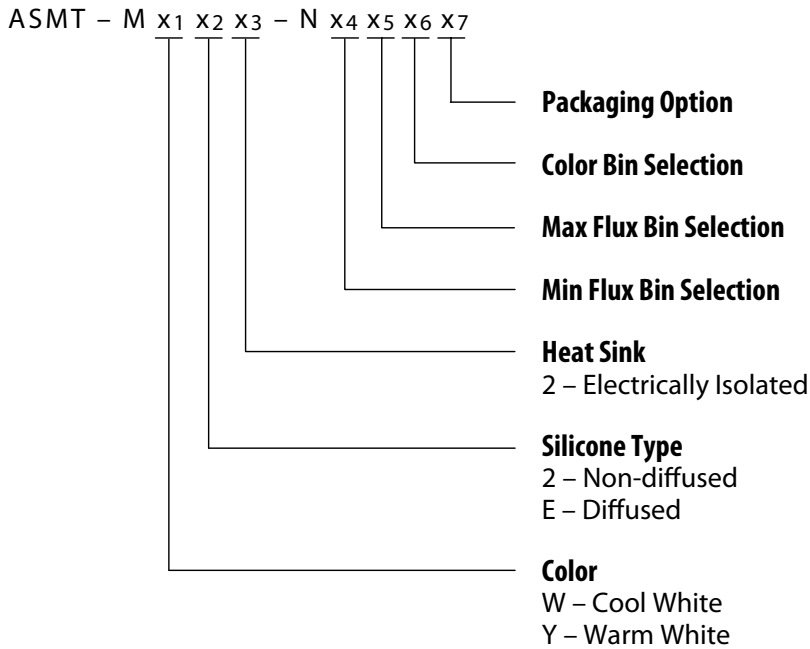

Figure 1. ASMT-Mx22 / ASMT-MxE2 package outline drawing.

### Notes:

1. All dimensions are in millimeters.
2. Unless otherwise stated, the tolerance for dimension is  $\pm 0.1$  mm.
3. Metal slug is connected to anode for electrically non-isolated option.

## Part Numbering System



Note:

1. Please refer to Page 8 for selection details.

## Device Selection Guide ( $T_J = 25^\circ\text{C}$ )

Part Number	Color	Luminous Flux, $\Phi_V$ [1,2] (lm)			Test Current (mA)	Die Technology	Electrically Isolated Metal Slug
		Min.	Typ.	Max.			
ASMT-MW22-NNP00	Cool White	110	120	140	350	InGaN	Yes
ASMT-MY22-NMP00	Warm White	95	100	140	350	InGaN	Yes
ASMT-MWE2-NNP00	Cool White Diffused	110	115	140	350	InGaN	Yes
ASMT-MYE2-NMP00	Warm White Diffused	95	98	140	350	InGaN	Yes

Notes:

1.  $\Phi_V$  is the total luminous flux output as measured with an integrating sphere at 25 ms mono pulse condition.
2. Flux tolerance is  $\pm 10\%$ .

## Absolute Maximum Ratings

Parameter	ASMT-Mx22 / ASMT-MxE2	Units
DC Forward Current <sup>[1]</sup>	700	mA
Peak Pulsing Current	2400	mA
Power Dissipation	2730	mW
LED Junction Temperature	125	°C
Operating Metal Slug Temperature Range at 350 mA	-40 to +110	°C
Operating Metal Slug Temperature Range at 700 mA	-40 to +95	°C
Storage Temperature Range	-40 to +120	°C
Soldering Temperature	Refer to Figure 11	
Reverse Voltage <sup>[2]</sup>	Not recommended	

Note:

1. Derate linearly based on Figure 9.
2. Not designed for reverse bias operation.

## Optical Characteristics at 350 mA ( $T_J = 25^\circ\text{C}$ )

Part Number	Color	Correlated Color Temperature, CCT (Kelvin)		Viewing Angle $2\theta_{1/2}$ <sup>[1]</sup> (°)	Luminous Efficiency (lm/W)
		Min.	Max.	Typ.	Typ.
ASMT-MW22-NNP00	Cool White	4000	10000	110	107
ASMT-MY22-NMP00	Warm White	2600	4000	110	89
ASMT-MWE2-NNP00	Cool White Diffused	4000	10000	110	103
ASMT-MYE2-NMP00	Warm White Diffused	2600	4000	110	88

Notes:

1.  $\theta_{1/2}$  is the off-axis angle where the luminous intensity is  $1/2$  the peak intensity.

**Electrical Characteristic at 350 mA ( $T_J = 25^\circ\text{C}$ )**

Dice Type	Forward Voltage, $V_F$ (Volts)			Thermal Resistance, $R_{\theta_{j-ms}}$ ( $^\circ\text{C/W}$ ) [1]	Temperature Coefficient of Forward Voltage ( $\text{mV}/^\circ\text{C}$ ), $\Delta V_F/\Delta T_J$
	Min.	Typ.	Max.	Typ.	Typ.
InGaN	2.8	3.2	3.5	10	-1.5 to -3.5

Note:

1.  $R_{\theta_{j-ms}}$  is the Thermal Resistance from LED junction to metal slug.

**Typical Characteristic at 700 mA ( $T_J = 25^\circ\text{C}$ )**

Part Number	Color	Luminous Flux, $\Phi_V$ (lm)	Forward Voltage, $V_F$ (Volts)
		Typ.	Typ.
ASMT-MW22-NNP00	Cool White	205	3.6
ASMT-MY22-NMP00	Warm White	170	3.6
ASMT-MWE2-NNP00	Cool White Diffused	196	3.6
ASMT-MYE2-NMP00	Warm White Diffused	167	3.6

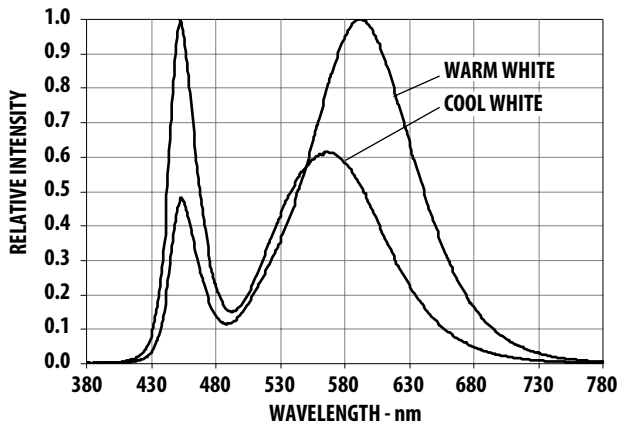

Figure 2. Relative Intensity vs. Wavelength.

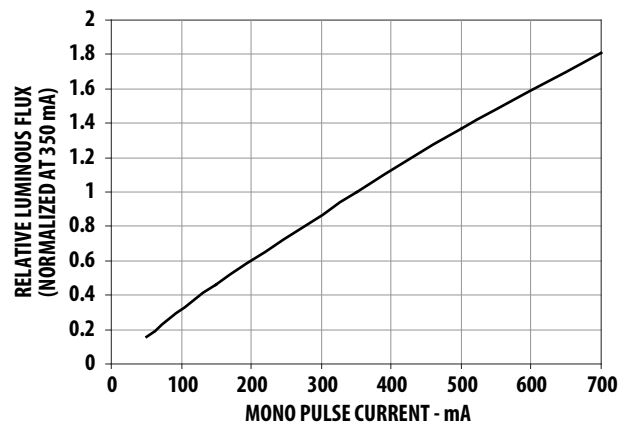

Figure 3. Relative Luminous Flux vs. Forward Current.

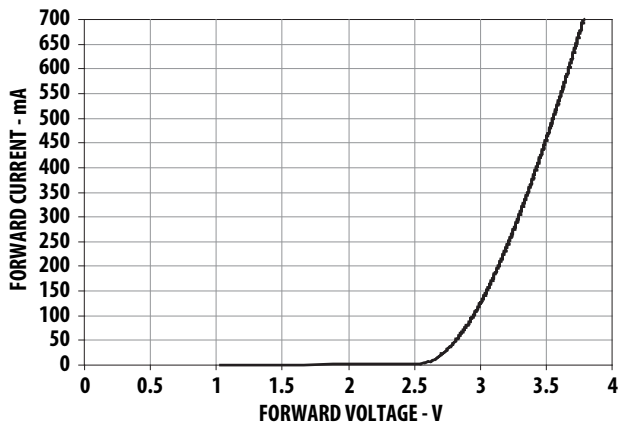

Figure 4. Forward Current vs. Forward Voltage.

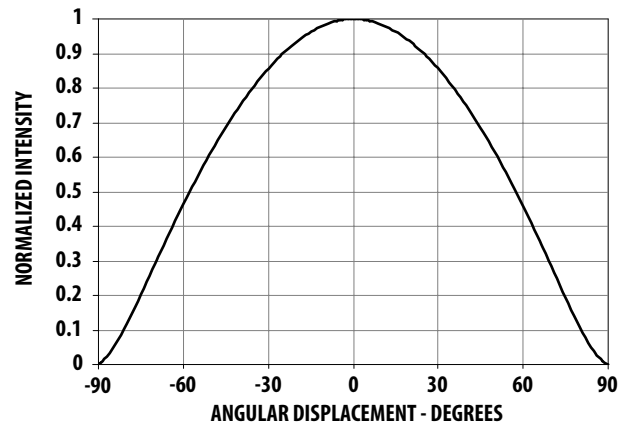

Figure 5. Radiation Pattern.

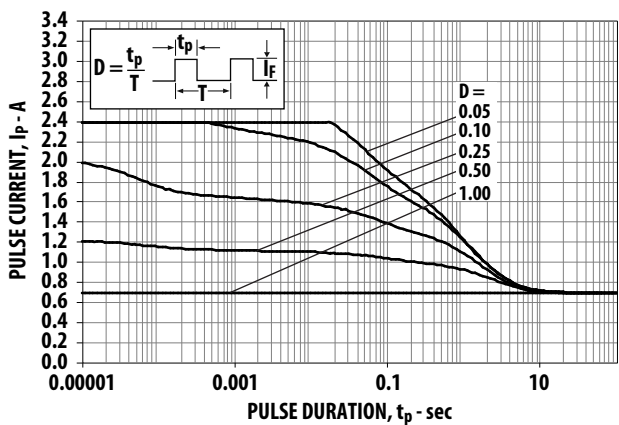

Figure 6. Maximum pulse current vs. pulse duration. Derated based on  $T_A = 25^\circ\text{C}$ ,  $R\theta_{J-A} = 30^\circ\text{C/W}$ .

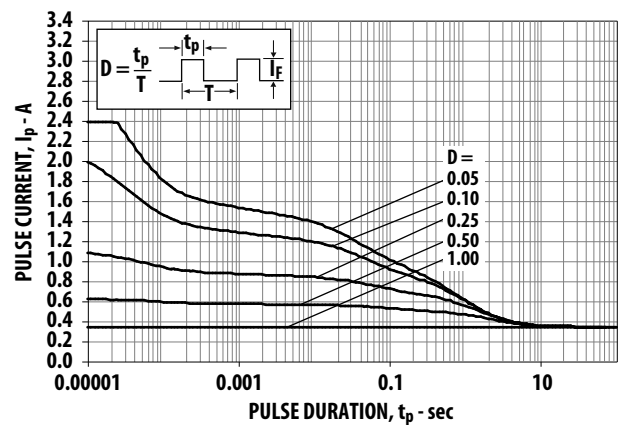

Figure 7. Maximum pulse current vs. pulse duration. Derated based on  $T_A = 85^\circ\text{C}$ ,  $R\theta_{J-A} = 30^\circ\text{C/W}$ .

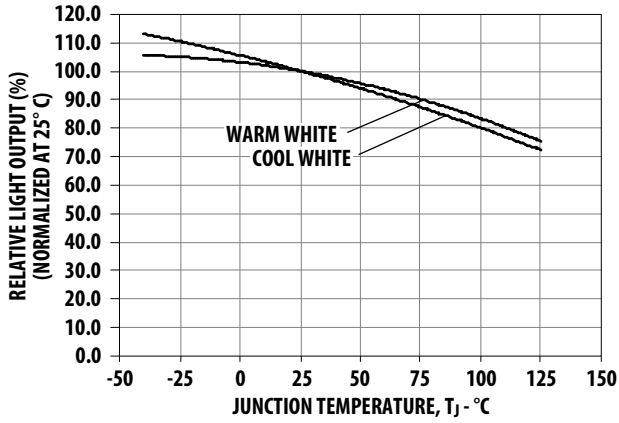

Figure 8. Relative Light Output vs. Junction Temperature.

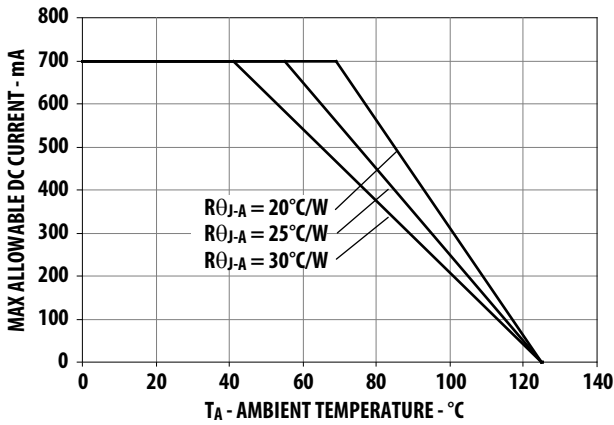

Figure 9. Maximum Forward Current vs. Ambient Temperature. Derated based on  $T_{JMAX} = 125^{\circ}C$ ,  $R_{\theta J-A} = 20^{\circ}C/W$ ,  $25^{\circ}C/W$  and  $30^{\circ}C/W$ .

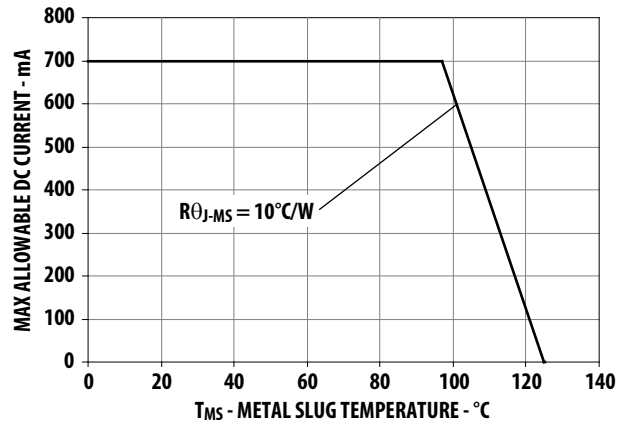

Figure 10. Maximum Forward Current vs. Metal Slug Temperature. Derated based on  $T_{JMAX} = 125^{\circ}C$ ,  $R_{\theta J-MS} = 10^{\circ}C/W$ .

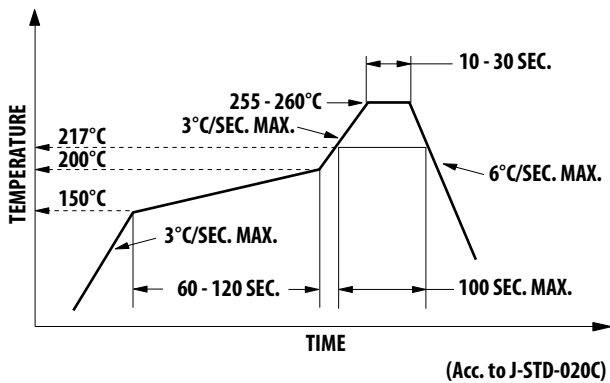

Figure 11. Recommended Reflow Soldering.

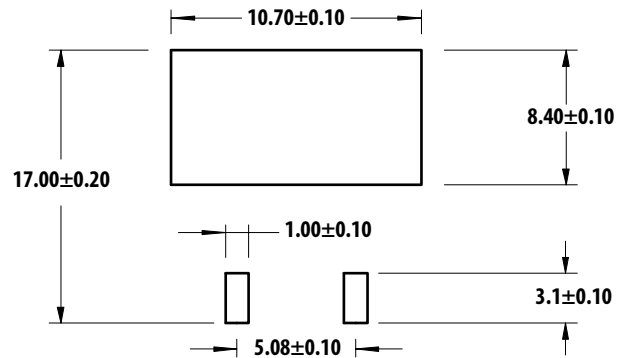

Figure 12. Recommended soldering land pattern.

Note:

For detail information on reflow soldering of Avago surface mount LEDs, do refer to Avago Application Note AN1060 Surface Mounting SMT LED Indicator Components.



## Option Selection Details

### ASMT – M x<sub>1</sub> x<sub>2</sub> x<sub>3</sub> – N x<sub>4</sub> x<sub>5</sub> x<sub>6</sub> x<sub>7</sub>

x<sub>4</sub> – Minimum Flux Bin

x<sub>5</sub> – Maximum Flux Bin

x<sub>6</sub> – Color Bin Selection

x<sub>7</sub> – Packaging Option

## Flux Bin Limit [x<sub>4</sub>, x<sub>5</sub>]

Bin	Luminous Flux (lm) at I <sub>F</sub> = 350mA	
	Min.	Max.
K	56.0	73.0
L	73.0	95.0
M	95.0	110.0
N	110.0	125.0
P	125.0	140.0

Tolerance for each bin limits is ±10%.

## Color Bin Selections [x<sub>3</sub>]

Individual reel will contain parts from one color bin selection only.

### Cool White

Selection	Bin ID
0	Full Distribution
A	A only
B	B only
C	C only
D	D only
E	E only
F	F only
G	G only
H	H only
L	A and G only
M	B and H only
N	A and C only
P	B and D only
Q	E and C only
R	F and D only
S	G and H only
U	E and F only
W	C and D only
Z	A and B only
1	A, B, C and D only
2	G, H, A and B only
4	C, D, E and F only

### Warm White

Selection	Bin ID
0	Full Distribution
A	A only
B	B only
C	C only
D	D only
E	E only
F	F only
N	A and C only
P	B and D only
Q	E and C only
R	F and D only
U	E and F only
W	C and D only
Z	A and B only
1	A, B, C and D only
4	C, D, E and F only

### Color Bin Limit

Cool White	Color Limits (Chromaticity Coordinates)				
		X	Y	X	Y
Bin A	X	0.367	0.362	0.329	0.329
	Y	0.400	0.372	0.345	0.369
Bin B	X	0.362	0.356	0.329	0.329
	Y	0.372	0.330	0.302	0.345
Bin C	X	0.329	0.329	0.305	0.301
	Y	0.369	0.345	0.322	0.342
Bin D	X	0.329	0.329	0.311	0.305
	Y	0.345	0.302	0.285	0.322
Bin E	X	0.303	0.307	0.283	0.274
	Y	0.333	0.311	0.284	0.301
Bin F	X	0.307	0.311	0.290	0.283
	Y	0.311	0.285	0.265	0.284
Bin G	X	0.388	0.379	0.362	0.367
	Y	0.417	0.383	0.372	0.400
Bin H	X	0.379	0.369	0.356	0.362
	Y	0.383	0.343	0.330	0.372

Tolerance:  $\pm 0.01$

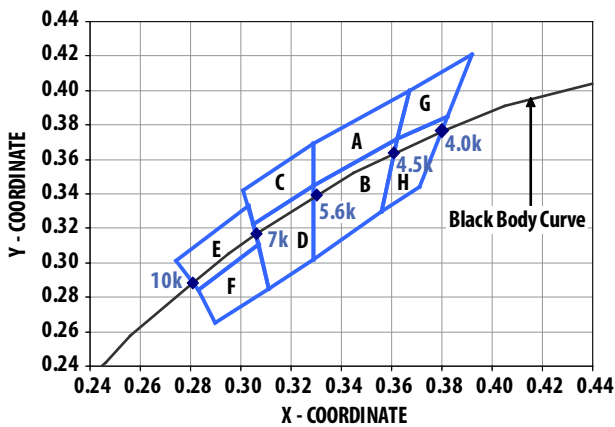

Figure 13. Color bins (Cool White).

### Packaging Option [x<sub>7</sub>]

Selection	Option
0	Tube
1	Tape and Reel

Warm White	Color Limits (Chromaticity Coordinates)				
		X	Y	X	Y
Bin A	X	0.452	0.488	0.470	0.438
	Y	0.434	0.447	0.414	0.403
Bin B	X	0.438	0.470	0.452	0.424
	Y	0.403	0.414	0.384	0.376
Bin C	X	0.407	0.418	0.452	0.438
	Y	0.393	0.422	0.434	0.403
Bin D	X	0.395	0.407	0.438	0.424
	Y	0.362	0.393	0.403	0.376
Bin E	X	0.381	0.387	0.418	0.407
	Y	0.377	0.404	0.422	0.393
Bin F	X	0.373	0.381	0.407	0.395
	Y	0.349	0.377	0.393	0.362

Tolerance:  $\pm 0.01$

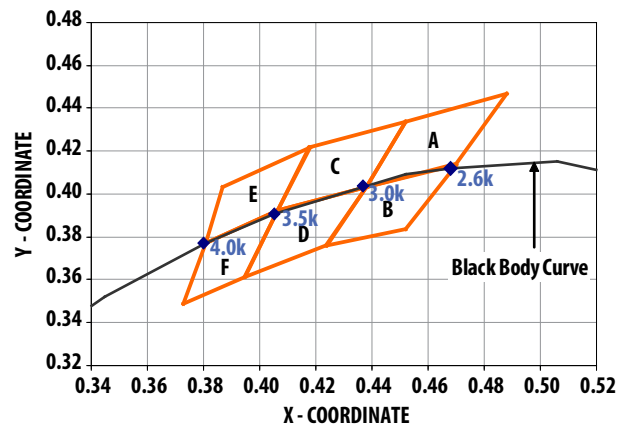

Figure 14. Color bins (Warm White).

### Example

#### ASMT-MW20-NLNZO

ASMT-MW20-Nxxxx – Cool White, Electrically Non-isolated  
Heat Sink, Non-diffused

- x<sub>4</sub> = L – Minimum Flux Bin L
- x<sub>5</sub> = N – Maximum Flux Bin N
- x<sub>6</sub> = Z – Color Bin A and B only
- x<sub>7</sub> = 0 – Tube Option

### Packing Tube – Option 0

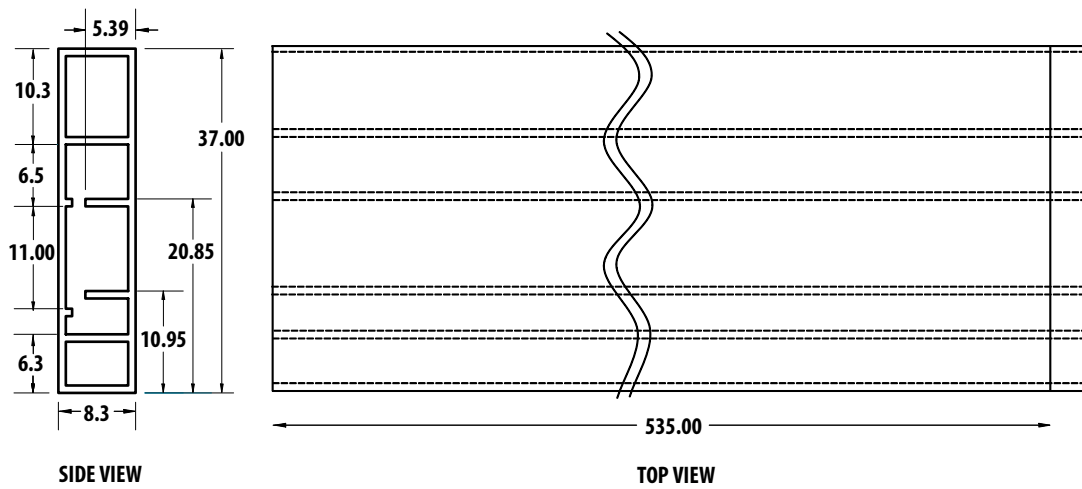

Figure 15. Tube dimensions

### Tape & Reel – Option 1

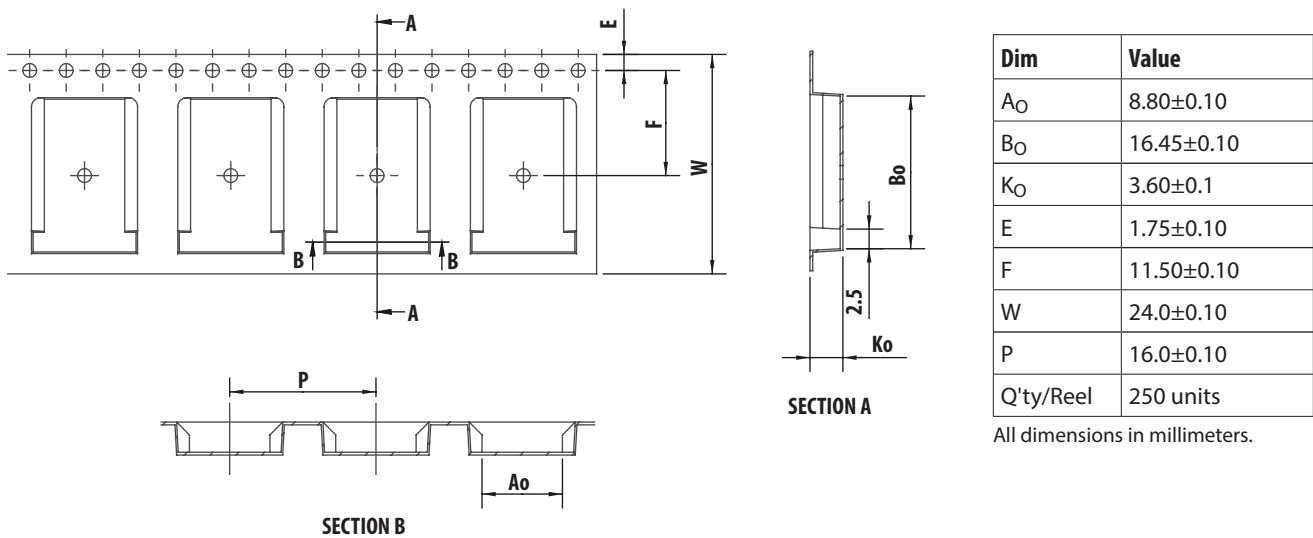

Figure 16. Carrier tape dimensions

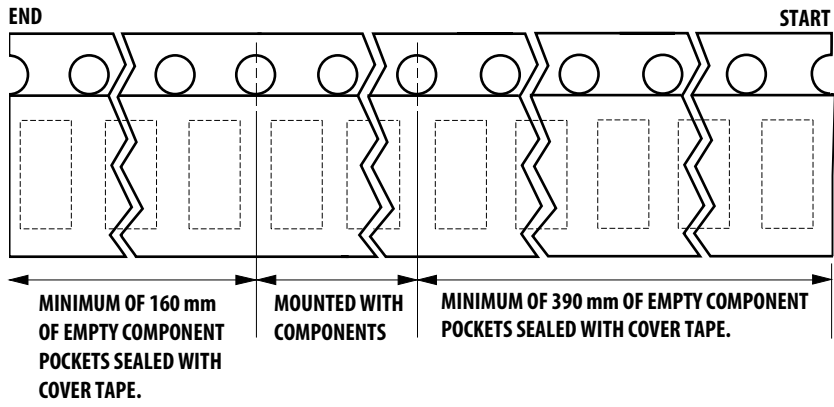

Figure 17. Carrier tape leader and trailer dimensions.

### Reel Dimension

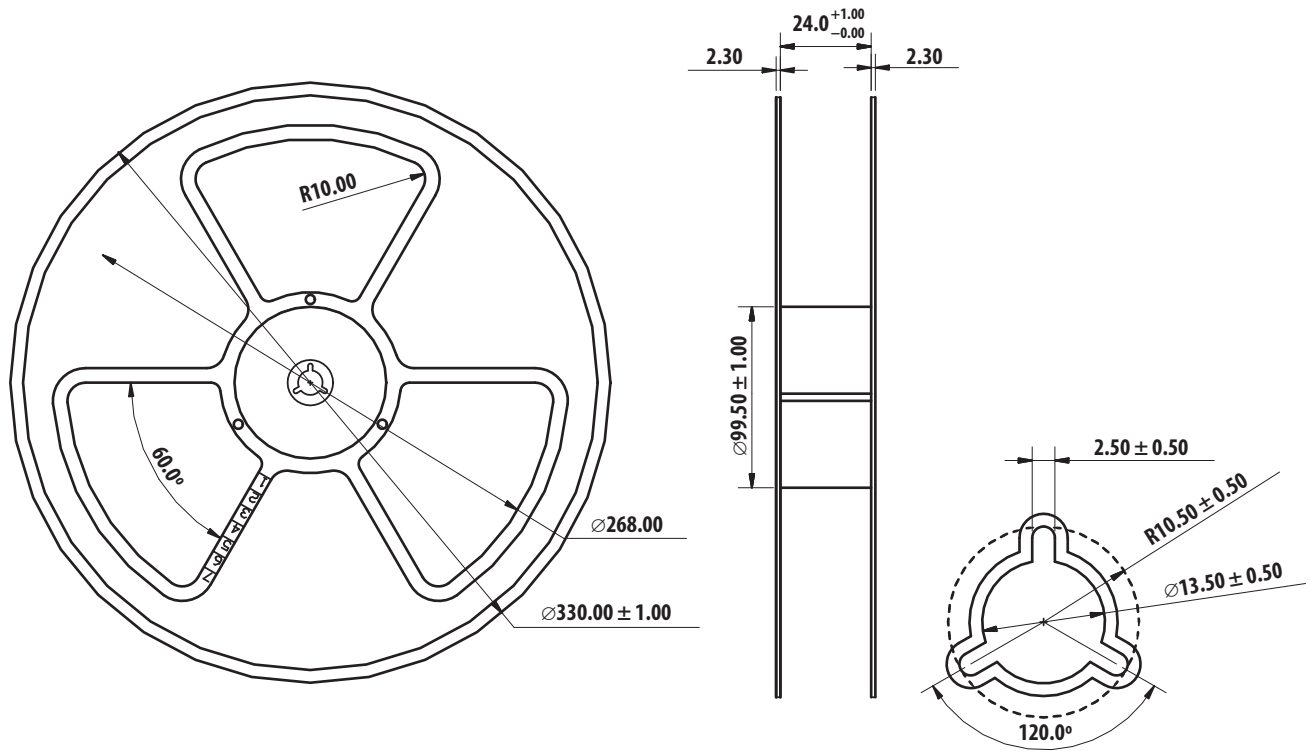

Figure 18. Reel dimensions.

## Handling Precaution

The encapsulation material of the product is made of silicone for better reliability of the product. As silicone is a soft material, please do not press on the silicone or poke a sharp object onto the silicone. These might damage the product and cause premature failure. During assembly or handling, the unit should be held on the body only. Please refer to Avago Application Note AN 5288 for detail information.

## Moisture Sensitivity

This product is qualified as Moisture Sensitive Level 4 per Jedec J-STD-020. Precautions when handling this moisture sensitive product is important to ensure the reliability of the product. Do refer to Avago Application Note AN5305 Handling of Moisture Sensitive Surface Mount Devices for details.

### A. Storage before use

- Unopen moisture barrier bag (MBB) can be stored at < 40°C/90%RH for 12 months. If the actual shelf life has exceeded 12 months and the humidity indicator card (HIC) indicates that baking is not required, then it is safe to reflow the LEDs per the original MSL rating.
- It is not recommended to open the MBB prior to assembly (e.g. for IQC).

### B. Control after opening the MBB

- The humidity indicator card (HIC) shall be read immediately upon opening of MBB.
- The LEDs must be kept at < 30°C/60%RH at all time and all high temperature related process including soldering, curing or rework need to be completed within 72 hours.

### C. Control for unfinished reel

- For any unused LEDs, they need to be stored in sealed MBB with desiccant or desiccator at < 5%RH.

### D. Control of assembly boards

- If the PCB soldered with the LEDs is to be subjected to other high temperature processes, the PCB need to be stored in sealed MBB with desiccant or desiccator at < 5%RH to ensure no LEDs have exceeded their floor life of 72 hours.

### E. Baking is required if

- HIC “10%” indicator is not blue and “5%” indicator is pink.
- The LEDs are exposed to condition of > 30°C/60%RH at any time.
- The LEDs floor life exceeded 72 hrs.

Recommended baking condition: 60±5°C for 20 hrs.

**DISCLAIMER:** Avago's products and software are not specifically designed, manufactured or authorized for sale as parts, components or assemblies for the planning, construction, maintenance or direct operation of a nuclear facility or for use in medical devices or applications. Customer is solely responsible, and waives all rights to make claims against avago or its suppliers, for all loss, damage, expense or liability in connection with such use.

For product information and a complete list of distributors, please go to our web site: [www.avagotech.com](http://www.avagotech.com)

Avago, Avago Technologies, and the A logo are trademarks of Avago Technologies in the United States and other countries. Data subject to change. Copyright © 2005-2012 Avago Technologies. All rights reserved. AV02-3158EN - December 10, 2012

**AVAGO**  
TECHNOLOGIES