



Chipsmall Limited consists of a professional team with an average of over 10 year of expertise in the distribution of electronic components. Based in Hongkong, we have already established firm and mutual-benefit business relationships with customers from,Europe,America and south Asia,supplying obsolete and hard-to-find components to meet their specific needs.

With the principle of “Quality Parts,Customers Priority,Honest Operation,and Considerate Service”,our business mainly focus on the distribution of electronic components. Line cards we deal with include Microchip,ALPS,ROHM,Xilinx,Pulse,ON,Everlight and Freescale. Main products comprise IC,Modules,Potentiometer,IC Socket,Relay,Connector.Our parts cover such applications as commercial,industrial, and automotives areas.

We are looking forward to setting up business relationship with you and hope to provide you with the best service and solution. Let us make a better world for our industry!



## Contact us

Tel: +86-755-8981 8866 Fax: +86-755-8427 6832

Email & Skype: info@chipsmall.com Web: www.chipsmall.com

Address: A1208, Overseas Decoration Building, #122 Zhenhua RD., Futian, Shenzhen, China



### Long Stroke, Sliding Contact Construction Sealed Switches

### Turquoise Stroke Mini Switches

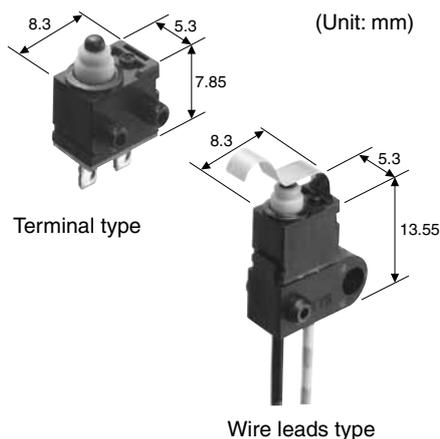

RoHS compliant

### FEATURES

- Miniaturization achieved with changing from 1 Form C to 1 Form A or 1 Form B contacts. (For the terminal type, volume has been cut 45% compared to our previous product.)
- Lever installation possible while it is small size. Operation possible by various moving parts such as metal cams.
- Contact force does not depend on the operation stroke.
- High contact reliability to support low level switching loads.
- Highly effective sealing for resistance against adverse environments. (IP67)
- Silent operation with sliding contacts.

### TYPICAL APPLICATIONS

- Automobiles (detection of door opening and closing, shift lever position, etc.)
- Household appliances (vacuum cleaners, air conditioners, washing machines, electric power tool, etc.)

### ORDERING INFORMATION

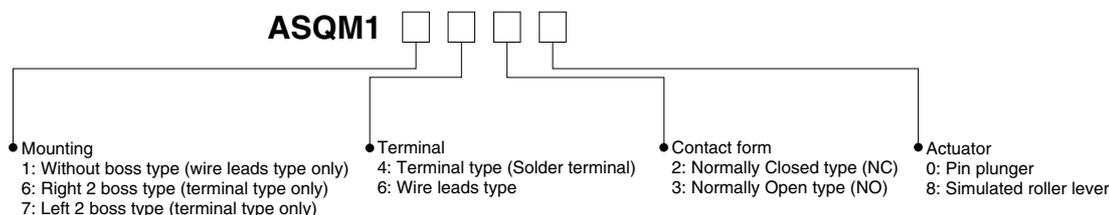

Note: Not every combination is available. Please refer to the following table, "PRODUCT TYPES".

### PRODUCT TYPES

#### Terminal type (solder terminal)

Carton: 1,000 pcs.

Actuator	Right 2 boss type		Left 2 boss type	
	Normally Closed type (NC)	Normally Open type (NO)	Normally Closed type (NC)	Normally Open type (NO)
Pin plunger	ASQM16420	ASQM16430	ASQM17420	ASQM17430
Simulated roller lever	ASQM16428	ASQM16438	ASQM17428	ASQM17438

#### Wire leads type

Carton: 240 pcs.

Actuator	Normally Closed type (NC)	Normally Open type (NO)
Pin plunger	ASQM11620	ASQM11630
Simulated roller lever	ASQM11628	ASQM11638

# Turquoise Stroke Mini Switches (ASQM1)

## SPECIFICATIONS

### ■ Contact rating

1 mA 5 V DC to 50 mA 16 V DC

### ■ Operation environment and conditions

Item	Specifications
Ambient and storage temperature	-40°C to +85°C (no freezing and condensing)
Allowable operating speed	30 to 500 mm/sec.
Max. operating cycle rate	120 cpm

Note: When switching at low and high speeds or under vibration, or in high-temperature, high-humidity environments, life and performance may be reduced significantly depending on the load capacity. Please consult us.

### ■ Electrical characteristics

Item	Specifications
Dielectric strength (Initial)	Between non-continuous terminals: 500 Vrms, Between each terminal and other exposed metal parts: 1,500 Vrms, Between each terminal and ground: 1,500 Vrms (at detection current of 1 mA)
Insulation resistance (Initial)	Min. 100 MΩ (at 500 V DC insulation resistance meter) (Locations measured same as dielectric strength.)
Contact resistance (Initial)	Max. 500 mΩ (by voltage drop 50 mA 6 to 8 V DC)

### ■ Characteristics

Item	Specifications
Electrical switching life	5 V DC 1 mA (Resistive load) Min. $3 \times 10^5$
	12 V DC 50 mA (Resistive load) Min. $2 \times 10^5$
	16 V DC 50 mA (Resistive load) Min. $1.5 \times 10^5$
Vibration resistance (malfunction vibration resistance)	Single amplitude: 0.75 mm Amplitude of vibration: 10 to 55 Hz (4 minutes cycle) Direction and time: 30 minutes each in X, Y and Z directions
	Amplitude of vibration: 5 to 200 Hz (10 minutes cycle) Acceleration: 43.1 m/s <sup>2</sup> Direction and time: 30 minutes each in X, Y and Z directions
Shock resistance (malfunction shock resistance)	Shock value: 980 m/s <sup>2</sup> Direction and time: 5 times each in X, Y and Z directions
Terminal strength	Min. 6 N (each direction) *Terminal deformation possible.
Heat resistance	85°C 500 hours
Cold resistance	-40°C 500 hours
Humidity resistance	40°C 95% RH 500 hours
Unit weight	Approx. 0.5 g (Terminal type), Approx. 3.9 g (Wire leads type)
Protection grade	IP67 (except exposed terminal part of terminal type)

Notes: As long as there are no particular designations, the following conditions apply to the test environment.

- Ambient temperature: 5 to 35°C
- Relative humidity: 25 to 85% RH
- Air pressure: 86 to 106 kPa

### ■ Protection grade

- 1) JIS C0920 (water-resistance experiments for electrical machines and protection rating against incursion of solid substances): Immersion protected (Note 1)
- 2) IEC 60529 (rating for outer shell protection): IP67 (Immersion protected) (Note 1)  
except metal terminal part (See below drawing)

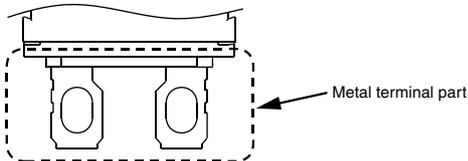

- 3) JIS D0203 (method for testing moisture resistance and water resistance in automotive components): Equivalent of D2 (Note 2)

Note 1) A concrete testing method is to check for any adverse effect on the structure after leaving it submerged for 30 minutes under 1 m of water (with temperature difference between water and switch no larger than 5°C).

Note 2) A concrete testing method is to check for any adverse effect on the structure after leaving it submerged for 10 minutes under 10 cm water (with temperature difference between water and switch no larger than 30°C).

## Operating characteristics

Characteristics		Pin plunger	Simulated roller lever
Operating Force (OF) max.		1.2N	1.5N
Total Travel Force (TF) max. (Reference value)		(3.0N)	(2.8N)
Free Position (FP) max.	Terminal type	7.7mm	13.4mm
	Wire leads type	14.45mm	20.15mm
Operating Position (OP)	Terminal type	Initial: 7.1±0.25mm After test: 7.1±0.3mm	Initial: 10.75±0.6mm After test: 10.75±0.7mm
	Wire leads type	Initial: 13.75±0.35mm After test: 13.75±0.4mm	Initial: 17.4±0.7mm After test: 17.4±0.8mm
Release Position (RP)	Terminal type	Initial: 7.15±0.3mm After test: 7.15±0.35mm	Initial: 11.05±0.7mm After test: 11.05±0.8mm
	Wire leads type	Initial: 13.8±0.4mm After test: 13.8±0.45mm	Initial: 17.7±0.8mm After test: 17.7±0.9mm
Over Travel (OT) min.	Terminal type	Initial: 1.75mm After test: 1.70mm	Initial: 2.25mm After test: 2.15mm
	Wire leads type	Initial: 1.65mm After test: 1.60mm	Initial: 2.15mm After test: 2.05mm
Total Travel Position (TTP) (Reference value)	Terminal type	(5.1mm)	(7.9mm)
	Wire leads type	(11.75mm)	(14.55mm)

Note: The above indicates the characteristics when operating the actuator from the vertical direction.

## DATA

### Applicable current range (Reference)

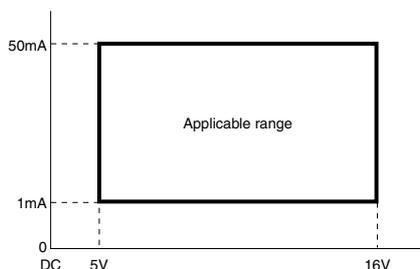

## DIMENSIONS (Unit: mm)

The CAD data of the products with a **CAD Data** mark can be downloaded from: <http://industrial.panasonic.com/ac/e/>

### Terminal type (Solder terminal), Right 2 boss type, Pin plunger

**CAD Data**

External dimensions

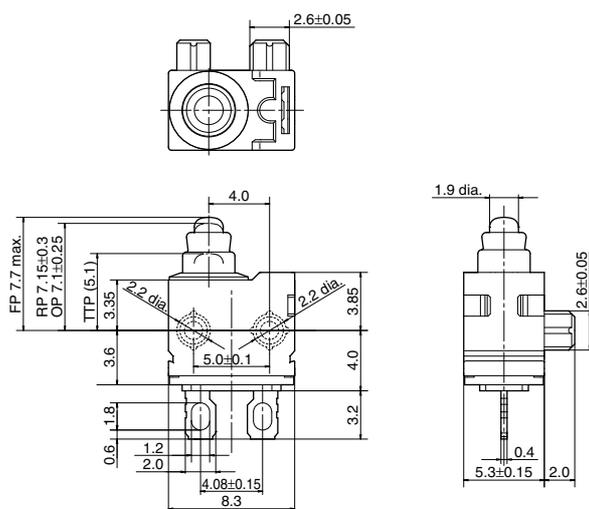

Operating Force (OF) max.	1.2N
Total Travel Force (TF) max. (Reference value)	(3.0N)
Free Position (FP) max.	7.7mm
Operating Position (OP)	Initial: 7.1±0.25mm After test: 7.1±0.3mm
Release Position (RP)	Initial: 7.15±0.3mm After test: 7.15±0.35mm
Over Travel (OT) min.	Initial: 1.75mm After test: 1.70mm
Total Travel Position (TTP) (Reference value)	(5.1mm)

General tolerance: ±0.25

# Turquoise Stroke Mini Switches (ASQM1)

## Terminal type (Solder terminal), Left 2 boss type, Pin plunger

### CAD Data

#### External dimensions

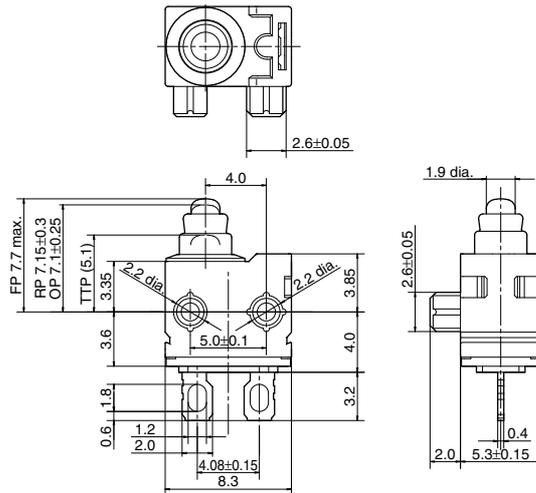

Operating Force (OF) max.	1.2N
Total Travel Force (TF) max. (Reference value)	(3.0N)
Free Position (FP) max.	7.7mm
Operating Position (OP)	Initial: 7.1±0.25mm After test: 7.1±0.3mm
Release Position (RP)	Initial: 7.15±0.3mm After test: 7.15±0.35mm
Over Travel (OT) min.	Initial: 1.75mm After test: 1.70mm
Total Travel Position (TTP) (Reference value)	(5.1mm)

General tolerance: ±0.25

## Terminal type (Solder terminal), Right 2 boss type, Simulated roller lever

### CAD Data

#### External dimensions

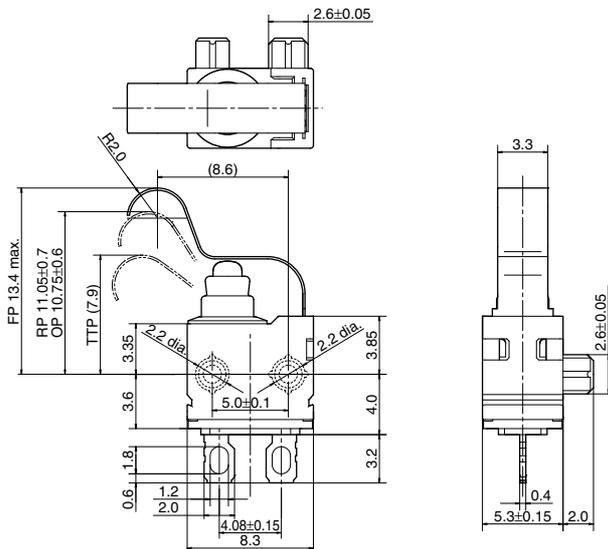

Operating Force (OF) max.	1.5N
Total Travel Force (TF) max. (Reference value)	(2.8N)
Free Position (FP) max.	13.4mm
Operating Position (OP)	Initial: 10.75±0.6mm After test: 10.75±0.7mm
Release Position (RP)	Initial: 11.05±0.7mm After test: 11.05±0.8mm
Over Travel (OT) min.	Initial: 2.25mm After test: 2.15mm
Total Travel Position (TTP) (Reference value)	(7.9mm)

General tolerance: ±0.25

## Terminal type (Solder terminal), Left 2 boss type, Simulated roller lever

### CAD Data

#### External dimensions

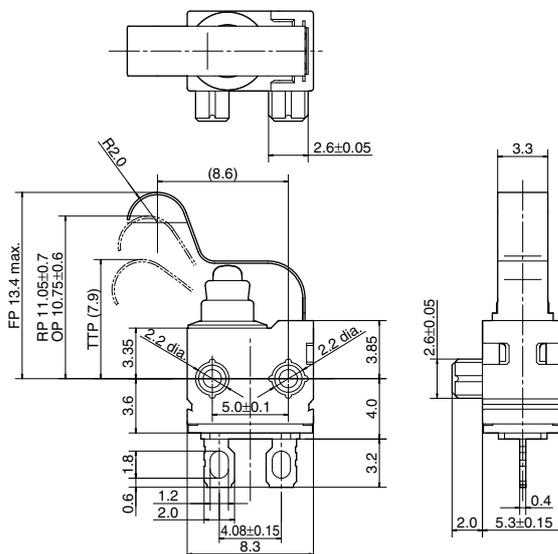

Operating Force (OF) max.	1.5N
Total Travel Force (TF) max. (Reference value)	(2.8N)
Free Position (FP) max.	13.4mm
Operating Position (OP)	Initial: 10.75±0.6mm After test: 10.75±0.7mm
Release Position (RP)	Initial: 11.05±0.7mm After test: 11.05±0.8mm
Over Travel (OT) min.	Initial: 2.25mm After test: 2.15mm
Total Travel Position (TTP) (Reference value)	(7.9mm)

General tolerance: ±0.25

## ■ Wire leads type, Pin plunger

### CAD Data

#### External dimensions

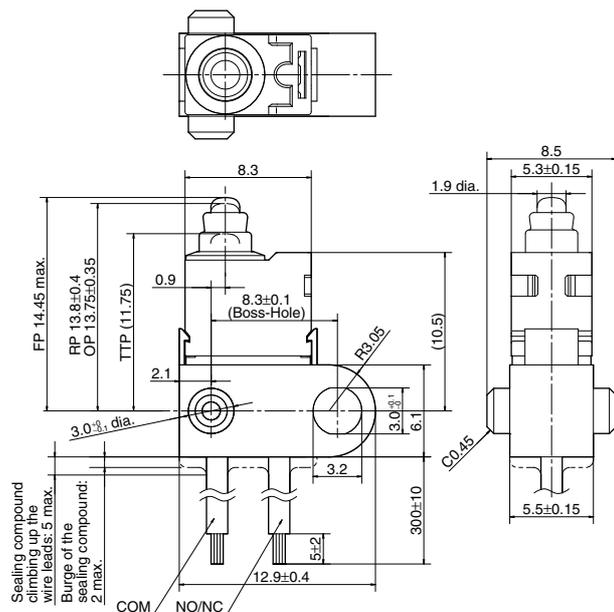

Operating Force (OF) max.	1.2N
Total Travel Force (TF) max. (Reference value)	(3.0N)
Free Position (FP) max.	14.45mm
Operating Position (OP)	Initial: 13.75±0.35mm After test: 13.75±0.4mm
Release Position (RP)	Initial: 13.8±0.4mm After test: 13.8±0.45mm
Over Travel (OT) min.	Initial: 1.65mm After test: 1.60mm
Total Travel Position (TTP) (Reference value)	(11.75mm)

General tolerance: ±0.25

## ■ Wire leads type, Simulated roller lever

### CAD Data

#### External dimensions

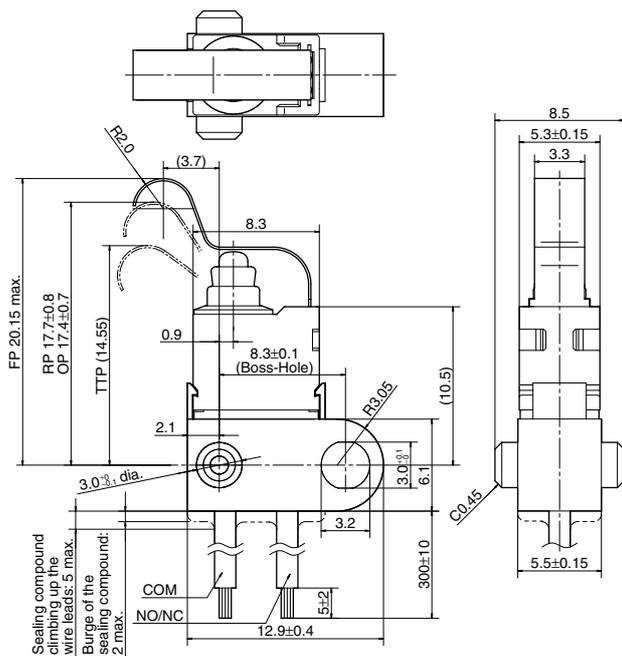

Operating Force (OF) max.	1.5N
Total Travel Force (TF) max. (Reference value)	(2.8N)
Free Position (FP) max.	20.15mm
Operating Position (OP)	Initial: 17.4±0.7mm After test: 17.4±0.8mm
Release Position (RP)	Initial: 17.7±0.8mm After test: 17.7±0.9mm
Over Travel (OT) min.	Initial: 2.15mm After test: 2.05mm
Total Travel Position (TTP) (Reference value)	(14.55mm)

General tolerance: ±0.25

## CAUTIONS FOR USE

### ■ Soldering conditions

- The application of excessive heat upon the switch when soldering can cause degradation of switch operation. Therefore, be sure to keep within the conditions given below.
- Manual soldering: Use soldering irons (max. 350°C, within 3 seconds) capable of temperature adjustment. This is to prevent deterioration due to soldering heat. Care should be taken not to apply force to the terminals during soldering. (More than one second interval is required to apply heat at each terminal.) Please consult us if you intend to use a soldering iron that exceeds 60 W.

### ■ Mounting

- To secure the wire leads type switch, please use M3 small screws on a flat surface and tighten using a maximum torque of 0.29 N·m. Be sure to verify the quality under actual conditions of use because the switch plastic might be deformed according to that the kind of the screw (size of screw head etc.), the diameter of the washer and the presence of washer. And use of adhesive lock is recommended to prevent loosening of the screws. When using an adhesive, care should be taken not to invade the adhesive into the switches.
- Be sure to maintain adequate insulating clearance between each terminal and ground.
- The positioning of the switch should be such that direct force is not applied to the plunger or actuator in its free position. The operating force to the plunger should only be applied in a perpendicular direction.
- When slanted press operation is applied to pin plunger type switches by an operation cam, the endurance life may greatly vary depending on the use of grease for sliding, operation angle, operation speed, operation frequency, press amount of the pin plunger, cam material, cam shape, cam surface condition, etc. Therefore fully verification by using the actual equipment in advance should be implemented.
- After mounting please make sure no pulling load will be applied to the switch terminals.

### ■ Cautions regarding the circuit

- In order to prevent malfunction in set devices caused by bounce and chattering during the ON-OFF switch operation, please verify the validity of the circuit under actual operating conditions and temperature range.
- When switching inductive loads (relays, solenoids, buzzers, etc.), it is recommended that contact protection element such as diode, varistor, etc., is introduced to prevent contact failure caused by electric discharge.

### ■ Please verify under actual conditions.

- Please be sure to conduct quality verification under actual operating conditions in order to increase reliability during actual use.

### ■ Selection of switch

- Please make your selection so that there will be no problems even if the operating characteristics vary up to  $\pm 20\%$  from the standard values.

### ■ Oil-proof and chemical-proof characteristics

- Do not use alcohol-based solvents.
- The rubber cap swells when exposed to oil and chemicals. The extent of swelling will vary widely depending on the type and amount of oil and chemicals. Check with the actual oil or chemicals used. In particular, be aware that solvents such as freon, chlorine, toluene, etc., cannot be used.

### ■ Operation environment

- Although continuous operation of the switch is possible within the range of ambient temperature (humidity), as the humidity range differs depending on the ambient temperature, the humidity range indicated below should be used. Continuous use near the limit of the range should be avoided. This temperature-humidity range does not guarantee permanent performance.

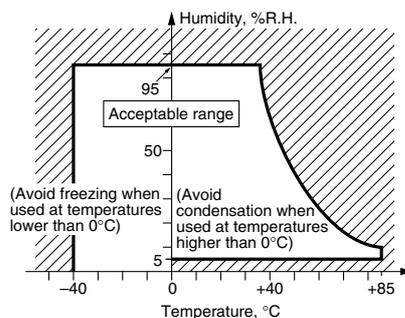

### ■ Others

- Do not handle the switch in a way that may cause damage to the sealing rubber cap.
- Please remember that this switch cannot be used under water. Also, please be warned that switching and sudden temperature changes with the presence of water droplets can cause seepage into the unit.
- Keep away from environments where silicon based adhesives, oil or grease are present as faulty contacts may result from silicon oxide. Do not use in areas where flammable or explosive gases from gasoline and thinner, etc., may be present.
- When using the lever type, please be careful not to apply unreasonable load from the reverse or lateral directions of operation.
- Do not exceed the total travel position (TTP) and press the actuator. This could cause operation failure. Also, when switching at high speed or under shock even within the operation limit, the working life may decrease. Therefore, please be sure to verify the quality under actual conditions of use.
- Please make considerations so that the switch does not become the stopper for the moving part.
- Do not use the switch which was dropped by mistakes when handling. If it is used, abnormal operation characteristics and sealing performance may occur.
- In case of applying coating to movable parts (actuator, plunger, etc.), the quality of the product is not guaranteed because it may cause a product failure.
- In case of cleaning a switch, the quality of the product is not guaranteed because it may cause a product failure.
- Do not apply ultrasonic vibrations and high frequency vibration to a switch because it may have an impact on the characteristics of the switch.
- Please do not constantly apply a tensile load to wire leads when fixing them.

# Notes for Turquoise Switches (BJ, BS, BV type)

## CAUTIONS FOR USE (Common for BJ, BS and BV types)

### ■ Fastening of the switch body

1) Fasten the switch body onto a smooth surface using the correct screw as shown in the chart below and tighten it with the prescribed torque.

The switch case may deform depending on the type of screw (screw head diameter, etc.), the size of the washer, and the use or non-use of a washer. Therefore, please confirm the appropriate torque of actual conditions. Also, it is recommended that adhesive be applied to lock the screws to prevent loosening of the screws. When doing so, please be careful not let any adhesive get inside the switch.

	Screws	Tightening torque
ABJ (BJ) switches	M1.2	Not more than 0.098N·m
	M2.3	Not more than 0.29N·m
	M3.0	Not more than 0.29N·m
ABS (BS) switches	M2.3	Not more than 0.29N·m
ABV (BV) switches	M3.0	Not more than 0.49N·m

### 2) Fixed pin type

To secure the switch unit, thermally crimp or press-fit the mounting pins. If the pins are to be press-fitted, install a guide on the opposite surface to the mounting pins to prevent them from slipping out of position and developing play.

3) Be sure to maintain adequate insulating clearance between each terminal and ground.

4) The positioning of the switch should be such that direct force is not applied to the pushbutton or actuator in its free position. The operating force to the pushbutton should only be applied in a perpendicular direction.

5) The standard value of overtravel used should be within the range of 70% to 100% of the rated OT value.

6) When soldering the BV type turquoise switch or the immersion protected type of the BJ and BS type switches, the sealing material sometimes forms a lump or bulge at the base of the terminal or lead. Be sure to allow enough space for this when attaching the switch.

### ■ Soldering operations

1) Manual soldering: Perform soldering in less than 3 seconds with maximum 350°C iron. Care should be taken not to apply force to the terminals during soldering. We recommend a soldering iron with temperature adjustment in order to prevent poor quality soldering.

Please consult us if you intend to use a soldering iron of 60 W or higher.

2) Terminal portions should not be moved within 1 minute after soldering.

	Soldering time
ABJ (BJ) switches	Within 3 seconds
ABS (BS) switches	Within 3 seconds
ABV (BV) switches	Within 5 seconds

### ■ Selection of the switch

Allow for up to  $\pm 20\%$  variation of the specified characteristics values to compensate for long term operational wear of the switch in your design.

### ■ Cautions regarding use

1) When switching inductive loads (relays, solenoids, buzzers, etc.), an arc absorbing circuit is recommended to protect the contacts.

2) If switching of the contact is synchronized with the phase of the AC power, reduced electrical life or welded contact may occur. Therefore, test the switch while it is operating under actual loads for this condition. If found, you may wish to take corrective action in your design.

3) In the slow or high speed operating condition, the electrical life might be greatly reduced depending upon the switching load. Please consult us before use.

4) Using lever type in do not condition, there is the concern that the flexible part may be impeded and return movement may not be possible. In this situation take the following precautions:

- Select a product of higher OF or use a leaf type lever.
- Attach a protective cover to the lever.

5) If the leaf lever type switch is excessively pushed (pushed further than the operational limit position) or switching is done at high speed or is accompanied by the impact, the lever will break. Please be careful. Also, be careful with the short roller lever type ABV (BV) switch as improper return may result from pressing too much.

### ■ Protection from dust, water and corrosive gas

1) The pin button and the space around the body cap Turquoise switches are sealed with elastic material, the terminal portion is integrally molded. This prevents dust entry and protects the switch against corrosive gases. Wireleaded types are recommended for applications subject to water or oil splash. However, avoid soaking these immersion protected types in oil or water, because those types are not of completely oil tight construction.

2) Switch operation or rapid temperature change while water droplets are on the switch may cause the water invasion inside the switch because of breathing action on condensation. Especially do not use switch in a bath.

If sources of silicon gas are existing in the vicinity of the switch (silicon rubber, silicon oil, silicon coating, and silicon filler, etc.), silicon gas (low molecular siloxane, etc.) will be emitted and it will get into the product due to the permeability of the plastic. If the switch is used or stored in such an environment, silicon compound might generate on the contacts, cause the and faulty contacting. Therefore, please do not use sources that can emit silicon gas in the vicinity of the switch.

Do not use in areas where flammable or explosive gases from gasoline and thinner, etc., may be present.

# Notes for Turquoise Switches (BJ, BS, BV type)

## • Dust protection test

Test conditions: The talcum powder used shall be able to pass through a square- meshed sieve the nominal wire diameter of 7  $\mu\text{m}$ . The amount of talcum powder to be used is 2 kg per cubic metre of the test chamber volume. The duration of the test is 8 hours.

No damage observed after the test.

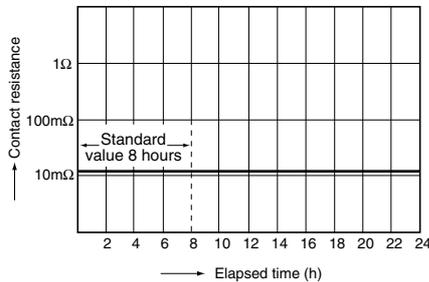

## • Waterproof test

Test conditions: Immersion protected IP67 switches ...  
Submerge at 1 m below the water surface for 30 minutes.

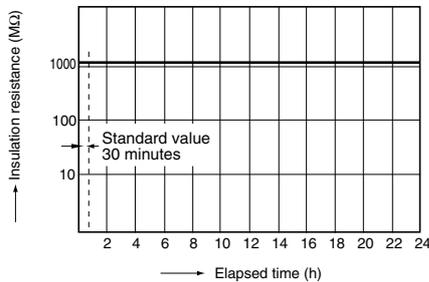

## • Hydrogen sulfide exposure test

Test conditions: Concentration: 3 ppm, Temperature: 40°C  
104°F, Humidity: 75% RH

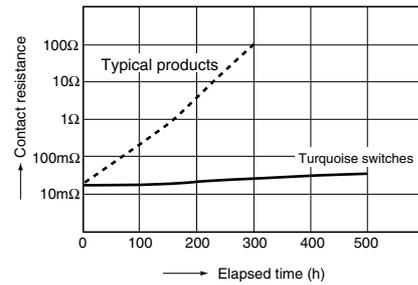

## ■ Oil-proof and chemical-proof characteristics

The rubber elastomer swells when exposed to oil and chemicals. The extent of swelling will vary widely depending on the type and amount of oil and chemicals.

Check with the actual oil or chemicals used.

In particular, be aware that solvents such as freon, chlorine, and toluene cannot be used.

## ■ Washability [ABJ (BJ) and ABS (BS)]

Do not clean the switch. Doing so can cause problems. Please contact us if cleaning is necessary.

## REFERENCE

### ■ Dust-protected type

This type of construction prevents dust that is large enough to have an effect on operation from getting inside the unit. This construction is stipulated by protective classes against solid matter in the IEC standards (IEC60529).

The talcum powder used shall be able to pass through a square-meshed sieve the nominal wire diameter of 7  $\mu\text{m}$ . The amount of talcum powder to be used is 2 kg per cubic metre of the test chamber volume. The duration of the test is 8 hours.

No damage observed after the test.

### ■ Immersion-protected type

This type of construction prevents any harmful effects even after the device is left underwater at a depth of 1 m for 30 minutes.

This construction is stipulated by protective classes against water in the IEC standards (IEC60529).

### ■ IEC's IP Codes

The IEC (International Electrotechnical Commission) has defined the IP characteristic code that represents the levels of protection described in IEC standard (IEC60529).

The two numbers that follow the IP code (the characteristics numbers) indicate the suitability of this protection for all environmental conditions.

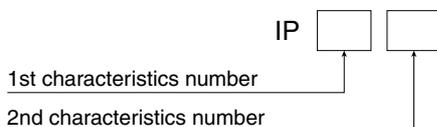

### • Level of protection indicated by the 1st Characteristics number

1st Characteristics number	Protection level (IEC60529/Solid matter)
0	No protection
1	Protected against solid matter larger than 50mm
2	Protected against solid matter larger than 12mm
3	Protected against solid matter larger than 2.5mm
4	Protected against solid matter larger than 1.0mm
5	Dust-protected type Prevents dust that is large enough to have an effect on operation from getting inside the unit
6	Dust-resistant type Prevents dust from getting inside the unit

### • Level of protection indicated by the 2nd Characteristics number

JIS C0920	2nd Characteristics number	Protection level (IEC60529/Liquid matter)
	0	No protection
Droplet-protected type I	1	Protected against water droplets that fall perpendicular to the unit
Droplet-protected type II	2	Protected against water droplets that fall from within 15° of perpendicular to the unit
Rain-protected type	3	Protected against water droplets that fall from within 60° of perpendicular to the unit
Splash-protected type	4	Protected against water that splashes on the unit from any direction
Spray-protected type	5	Free from adverse effects even if sprayed directly with water from any direction
Water-resistant type	6	Protected against water sprayed directly on the unit from any direction
Immersion-protected type	7	Water does not get inside of the unit when submerged in water according to the specified conditions
Underwater type	8	Unit can be used underwater

Note: Details of test conditions are the same as NECA C 0920. Please refer to them.

---

Please contact .....

**Panasonic Corporation**

Electromechanical Control Business Division

■ 1006, Oaza Kadoma, Kadoma-shi, Osaka 571-8506, Japan  
[industrial.panasonic.com/ac/e/](http://industrial.panasonic.com/ac/e/)

**Panasonic**<sup>®</sup>

©Panasonic Corporation 2017