



Chipsmall Limited consists of a professional team with an average of over 10 year of expertise in the distribution of electronic components. Based in Hongkong, we have already established firm and mutual-benefit business relationships with customers from,Europe,America and south Asia,supplying obsolete and hard-to-find components to meet their specific needs.

With the principle of "Quality Parts,Customers Priority,Honest Operation,and Considerate Service",our business mainly focus on the distribution of electronic components. Line cards we deal with include Microchip,ALPS,ROHM,Xilinx,Pulse,ON,Everlight and Freescale. Main products comprise IC,Modules,Potentiometer,IC Socket,Relay,Connector.Our parts cover such applications as commercial,industrial, and automotives areas.

We are looking forward to setting up business relationship with you and hope to provide you with the best service and solution. Let us make a better world for our industry!



Contact us

Tel: +86-755-8981 8866 Fax: +86-755-8427 6832

Email & Skype: info@chipsmall.com Web: www.chipsmall.com

Address: A1208, Overseas Decoration Building, #122 Zhenhua RD., Futian, Shenzhen, China



AST3TQ Evaluation Board

AST3TQ-Eval

Moisture Sensitivity Level – N/A



RoHS/RoHS II compliant



39.43 x 42.72mm

DESCRIPTION:

AST3TQ Evaluation boards are designed to facilitate the electrical performance testing of the AST3TQ series of TCXO's and VCTCXO's. Customers simply solder down the AST3TQ device on the provided land-pattern and connect +3.3V to the SMA connector marked as "Vdd" and monitor the RF Output at the SMA marked as "Out". For the TCXO version, the "VC" port SMA connector should be left floating. For the VCTCXO version of the AST3TQ devices, this port should be connected to a DC Voltage between 0.00V and +3.30V. Please follow the recommended center voltage value specified in the product data sheet for the device under test (DUT), to be on frequency relative to the carrier.

OPTIONS AND PART IDENTIFICATION

AST3TQ-EVAL

OUTLINE DIMENSIONS

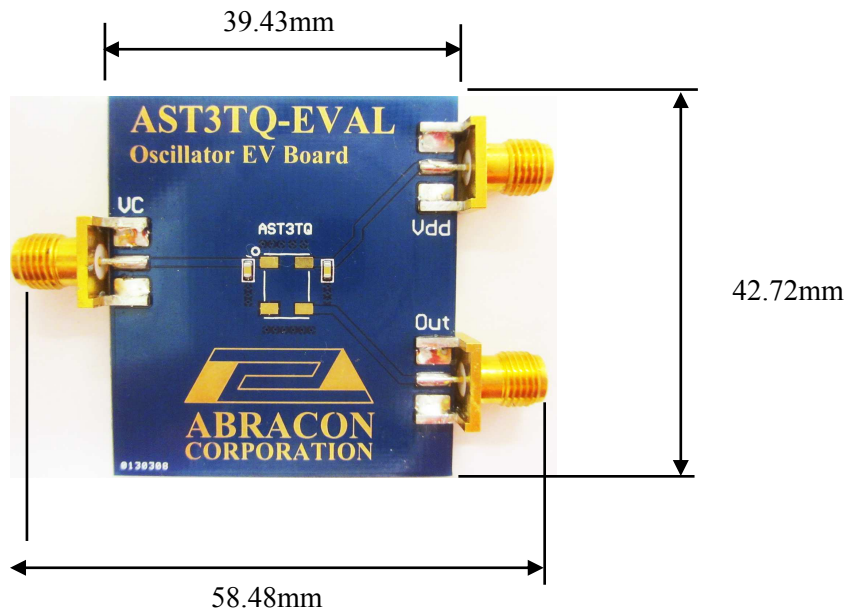

ABRACON IS
ISO9001:2008
CERTIFIED



2 Faraday, Suite# B | Irvine | CA 92618 **Revised: 01.23.15**
Ph. 949.546.8000 | Fax. 949.546.8001
Visit www.abracon.com for Terms and Conditions of Sale

AST3TQ Evaluation Board

AST3TQ-Eval

Moisture Sensitivity Level – N/A



RoHS/RoHS II compliant



39.43 x 42.72mm

SCHEMATIC

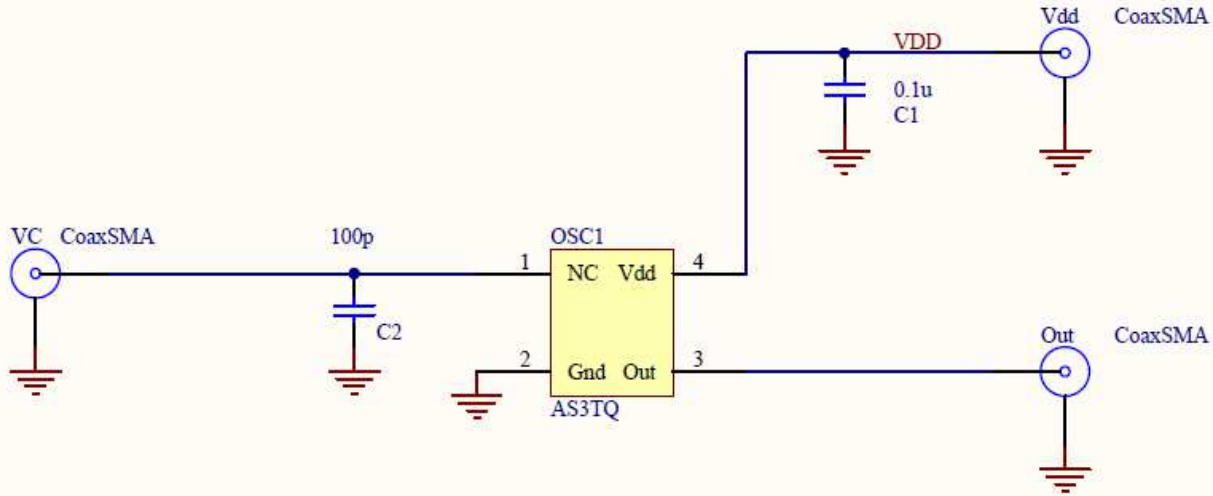

LAYOUT

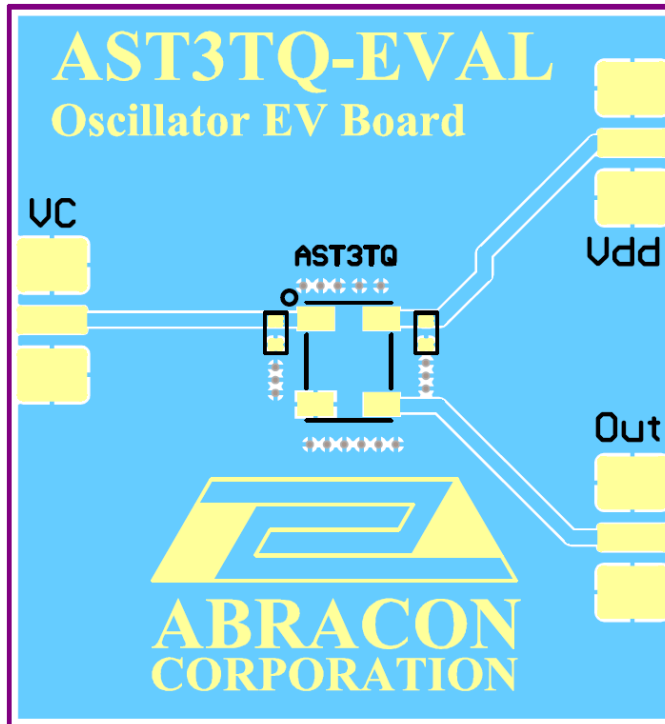

ATTENTION: Abracon Corporation's products are COTS – Commercial-Off-The-Shelf products; suitable for Commercial, Industrial and, where designated, Automotive Applications. Abracon's products are not specifically designed for Military, Aviation, Aerospace, Life-dependant Medical applications or any application requiring high reliability where component failure could result in loss of life and/or property. For applications requiring high reliability and/or presenting an extreme operating environment, written consent and authorization from Abracon Corporation is required. Please contact Abracon Corporation for more information.

ABRACON IS
ISO9001:2008
CERTIFIED



2 Faraday, Suite# B | Irvine | CA 92618 **Revised: 01.23.15**

Ph. 949.546.8000 | Fax. 949.546.8001

Visit www.abracon.com for Terms and Conditions of Sale