



Chipsmall Limited consists of a professional team with an average of over 10 year of expertise in the distribution of electronic components. Based in Hongkong, we have already established firm and mutual-benefit business relationships with customers from,Europe,America and south Asia,supplying obsolete and hard-to-find components to meet their specific needs.

With the principle of “Quality Parts,Customers Priority,Honest Operation,and Considerate Service”,our business mainly focus on the distribution of electronic components. Line cards we deal with include Microchip,ALPS,ROHM,Xilinx,Pulse,ON,Everlight and Freescale. Main products comprise IC,Modules,Potentiometer,IC Socket,Relay,Connector.Our parts cover such applications as commercial,industrial, and automotives areas.

We are looking forward to setting up business relationship with you and hope to provide you with the best service and solution. Let us make a better world for our industry!



Contact us

Tel: +86-755-8981 8866 Fax: +86-755-8427 6832

Email & Skype: info@chipsmall.com Web: www.chipsmall.com

Address: A1208, Overseas Decoration Building, #122 Zhenhua RD., Futian, Shenzhen, China





AT40K05, AT40K10, AT40K20, AT40K40

5K – 50K Gates Coprocessor FPGA with FreeRAM™

DATASHEET

Features

- Ultra high performance
 - System speeds to 100MHz
 - Array multipliers > 50MHz
 - 10ns flexible SRAM
 - Internal tri-state capability in each cell
- FreeRAM™
 - Flexible, single/dual port, synchronous/asynchronous 10ns SRAM
 - 2,048 – 18,432 bits of distributed SRAM independent of logic cells
- 128 – 384 PCI compliant I/Os
 - 5V capability
 - Programmable output drive
 - Fast, flexible array access facilitates pin locking
 - Pin-compatible with XC4000 and XC5200 FPGAs
- Eight global clocks
 - Fast, low skew clock distribution
 - Programmable rising/falling edge transitions
 - Distributed clock shutdown capability for low power management
 - Global reset/asynchronous reset options
 - 4 additional dedicated PCI clocks
- Cache Logic® dynamic full/partial re-configurability in-system
 - Unlimited re-programmability via serial or parallel modes
 - Enables adaptive designs
 - Enables fast vector multiplier updates
- Pin-compatible package options
 - Thin, Plastic Quad Flat Packs (LQFP and PQFP)
- User-friendly design tools
 - Timing driven placement and routing
 - Automatic/Interactive multi-chip partitioning
 - Fast, efficient synthesis
 - Over 75 automatic component generators create 1000s of reusable, Fully Deterministic Logic and RAM functions
- Intellectual property cores
 - Fir Filters, UARTs, PCI, FFT, and other system level functions
- Supply voltage 5V for AT40K

Table 1. AT40K Series Family⁽¹⁾

Device	AT40K05	AT40K10	AT40K20	AT40K40
Usable Gates	5K – 10K	10K – 20K	20K – 30K	40K – 50K
Rows x Columns	16 x 16	24 x 24	32 x 32	48 x 48
Cells	256	576	1,024	2,304
Registers	256 ⁽¹⁾	576 ⁽¹⁾	1,024 ⁽¹⁾	2,304 ⁽¹⁾
RAM Bits	2,048	4,608	8,192	18,432
I/O (Maximum)	128	192	256	384

Note: 1. Packages with FCK will have eight less registers.

1. Description

The AT40K is a family of fully PCI-compliant, SRAM-based FPGAs with distributed 10ns programmable synchronous/asynchronous, dual-port/single-port SRAM, eight global clocks, Cache Logic ability (partially or fully reconfigurable without loss of data), automatic component generators, and range in size from 5,000 to 50,000 usable gates. I/O counts range from 128 to 384 in industry standard packages ranging from 84-pin PLCC to 352-ball Square BGA, and support 5V designs for AT40K.

The AT40K is designed to quickly implement high-performance, large gate count designs through the use of synthesis, and schematic-based tools used on a PC or Sun platform. Atmel's design tools provide seamless integration with industry standard tools such as Synplicity, ModelSim, Exemplar and Viewlogic.

The AT40K can be used as a coprocessor for high-speed (DSP/processor-based) designs by implementing a variety of computation intensive, arithmetic functions. These include adaptive finite impulse response (FIR) filters, fast Fourier transforms (FFT), convolvers, interpolators and discrete-cosine transforms (DCT) that are required for video compression and decompression, encryption, convolution, and other multimedia applications.

1.1 Fast, Flexible and Efficient SRAM

The AT40K FPGA offers a patented distributed 10ns SRAM capability where the RAM can be used without losing logic resources. Multiple independent, synchronous or asynchronous, dual-port or single-port RAM functions (FIFO, scratch pad, etc.) can be created using Atmel's macro generator tool.

1.2 Fast, Efficient Array, and Vector Multipliers

The AT40K's patented 8-sided core cell with direct horizontal, vertical, and diagonal cell-to-cell connections implements ultra fast array multipliers without using any busing resources. The AT40K/AT40KLV's Cache Logic capability enables a large number of design coefficients and variables to be implemented in a very small amount of silicon, enabling vast improvement in system speed at much lower cost than conventional FPGAs.

1.3 Cache Logic Design

The AT40K, AT6000, and FPSLIC families are capable of implementing Cache Logic (dynamic full/partial logic reconfiguration, without loss of data, on-the-fly) for building adaptive logic and systems. As new logic functions are required, they can be loaded into the logic cache without losing the data already there or disrupting the operation of the rest of the chip; replacing or complementing the active logic. The AT40K can act as a reconfigurable coprocessor.

1.4 Automatic Component Generators

The AT40K FPGA family is capable of implementing user-defined, automatically generated, macros in multiple designs, speed, and functionality are unaffected by the macro orientation or density of the target device. This enables the fastest, most predictable and efficient FPGA design approach and minimizes design risk by reusing already proven functions. The Automatic Component Generators work seamlessly with industry standard schematic and synthesis tools to create the fastest, most efficient designs available.

The patented AT40K series architecture employs a symmetrical grid of small yet powerful cells connected to a flexible busing network. Independently controlled clocks and resets govern every column of cells. The array is surrounded by programmable I/O.

Devices range in size from 5,000 to 50,000 usable gates in the family, and have 256 to 2,304 registers. Pin locations are consistent throughout the AT40K series for easy design migration in the same package footprint. The AT40K series FPGAs utilize a reliable 0.6 μ single-poly, CMOS process, and are 100% factory-tested. Atmel's PC-based Integrated Development System (IDS) is used to create AT40K series designs. Multiple design entry methods are supported.

The Atmel architecture was developed to provide the highest levels of performance, functional density and design flexibility in an FPGA. The cells in the Atmel array are small, efficient and can implement any pair of Boolean functions of (the same) three inputs or any single Boolean function of four inputs. The cell's small size leads to arrays with large numbers of cells, greatly multiplying the functionality in each cell. A simple, high-speed busing network provides fast, efficient communication over medium and long distances.

2. The Symmetrical Array

At the heart of the Atmel architecture is a symmetrical array of identical cells, see [Figure 2-1](#). The array is continuous from one edge to the other, except for bus repeaters spaced every four cells, see [Figure 2-2](#). At the intersection of each repeater row and column there is a 32 x 4 RAM block accessible by adjacent buses. The RAM can be configured as either a single-ported or dual-ported RAM⁽¹⁾, with either synchronous or asynchronous operation.

Note: 1. The right-most column can only be used as single-port RAM.

Figure 2-1. Symmetrical Array Surrounded by I/O (AT40K20)

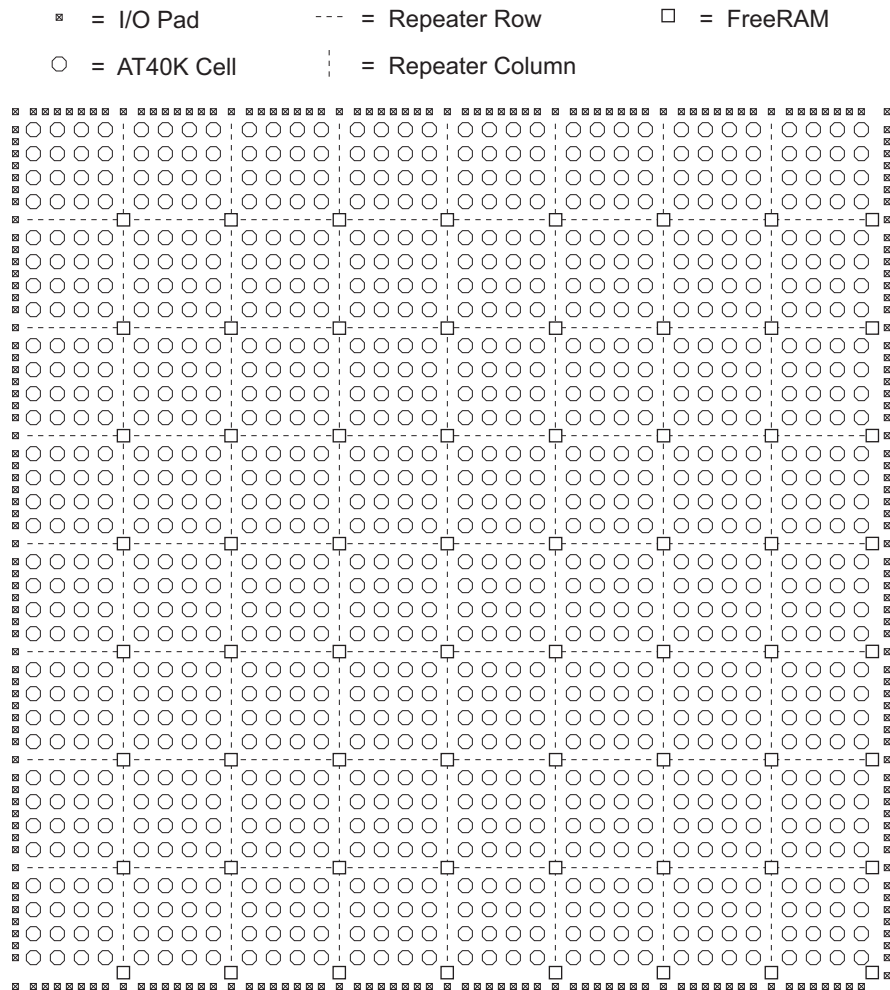
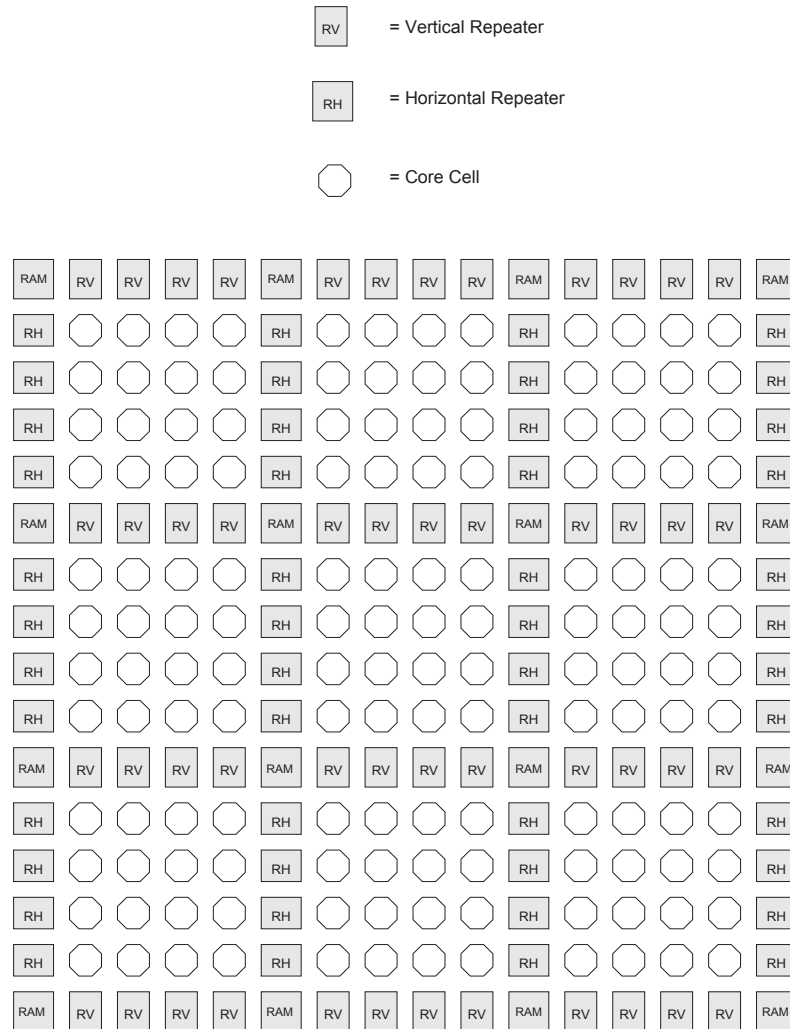

Figure 2-2. Floor Plan (Representative Portion)⁽¹⁾



Note: 1. Repeaters regenerate signals and can connect any bus to any other bus (all pathways are legal) on the same plane. Each repeater has connections to two adjacent local-bus segments and two express-bus segments. This is done automatically using the Integrated Development System (IDS) tool.

3. The Busing Network

Figure 3-1 depicts one of five identical busing planes. Each plane has three bus resources: a local-bus resource (the middle bus) and two express-bus (both sides) resources. Bus resources are connected via repeaters. Each repeater has connections to two adjacent local-bus segments and two express-bus segments. Each local-bus segment spans four cells and connects to consecutive repeaters. Each express-bus segment spans eight cells and “leapfrogs” or bypasses a repeater. Repeaters regenerate signals and can connect any bus to any other bus (all pathways are legal) on the same plane. Although not shown, a local bus can bypass a repeater via a programmable pass gate allowing long on-chip tri-state buses to be created. Local/Local turns are implemented through pass gates in the cell-bus interface. Express/Express turns are implemented through separate pass gates distributed throughout the array.

Some of the bus resources on the AT40K are used as a dual-function resources. Table 3-1 shows which buses are used in a dual-function mode and which bus plane is used. The AT40K software tools are designed to accommodate dual-function buses in an efficient manner.

Table 3-1. Dual-function Buses

Function	Type	Plane(s)	Direction	Comments
Cell Output Enable	Local	5	Horizontal and Vertical	
RAM Output Enable	Express	2	Vertical	Bus full length at array edge. Bus in first column to left of RAM block.
RAM Write Enable	Express	1	Vertical	Bus full length at array edge. Bus in first column to left of RAM block.
RAM Address	Express	1 – 5	Vertical	Buses full length at array edge. Buses in second column to left of RAM block.
RAM Data In	Local	1	Horizontal	Data In connects to local. Bus Plane 1.
RAM Data Out	Local	2	Horizontal	Data out connects to local. Bus Plane 2.
Clocking	Express	4	Vertical	Bus half length at array edge.
Set/Reset	Express	5	Vertical	Bus half length at array edge.

Figure 3-1. Busing Plane (One of Five)

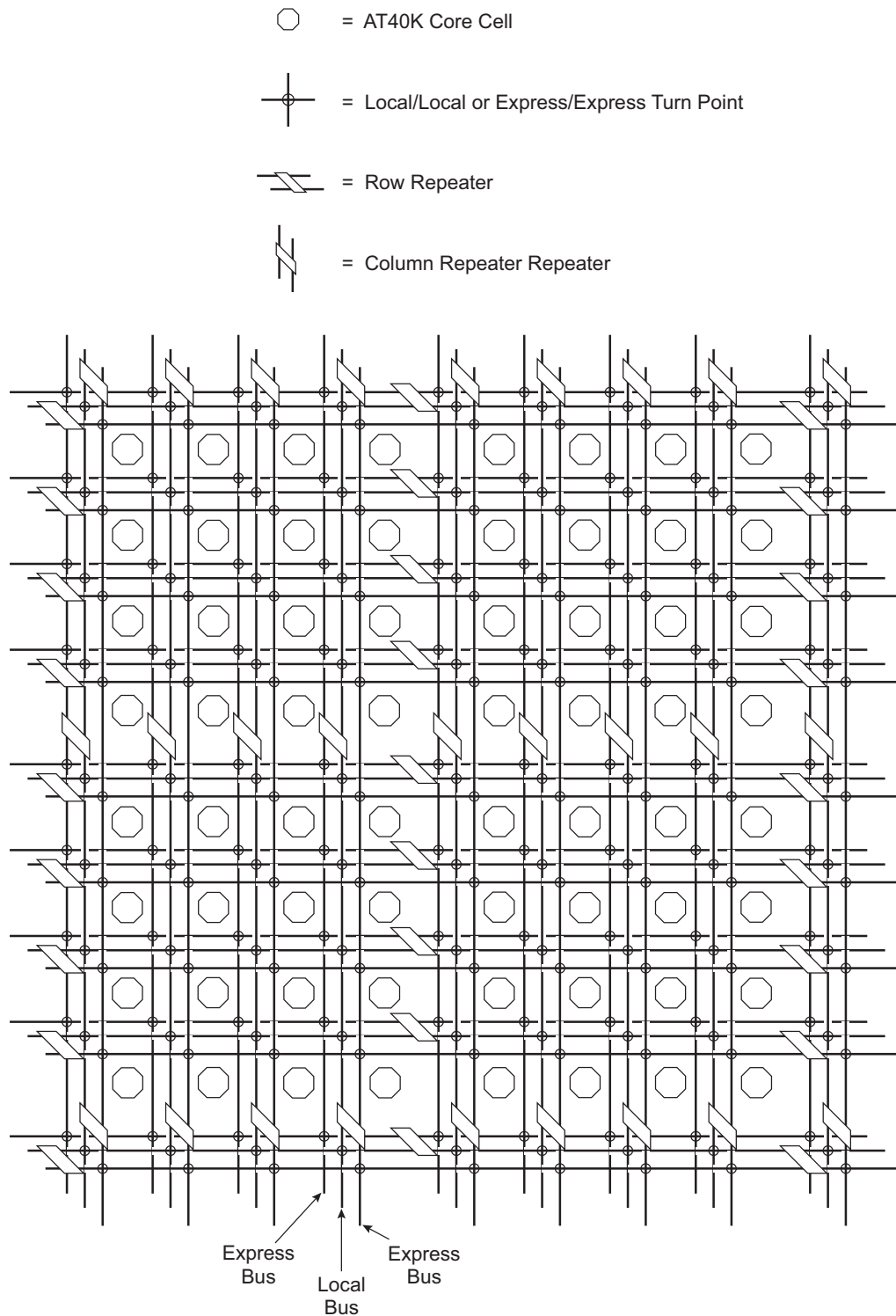

4. Cell Connections

Figure 4-1(a) depicts direct connections between a cell and its eight nearest neighbors. Figure 4-1(b) shows the connections between a cell and five horizontal local buses (one per busing plane) and five vertical local buses (one per busing plane).

Figure 4-1. Cell Connections

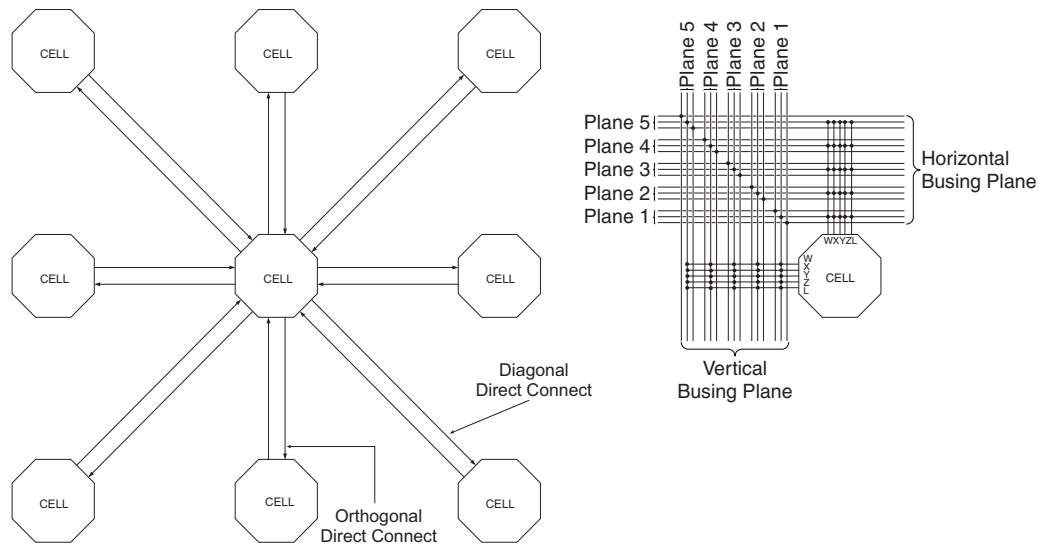

(a) Cell-to-cell Connections

(b) Cell-to-bus Connections

5. The Cell

Figure 5-1 depicts the AT40K cell. Configuration bits for separate muxes and pass gates are independent. All permutations of programmable muxes and pass gates are legal. V_n ($V_1 - V_5$) is connected to the vertical local bus in plane n . H_n ($H_1 - H_5$) is connected to the horizontal local bus in plane n . A local/local turn in plane n is achieved by turning on the two pass gates connected to V_n and H_n . Pass gates are opened to let signals into the cell from a local bus or to drive a signal out onto a local bus. Signals coming into the logic cell on one local bus plane can be switched onto another plane by opening two of the pass gates. This allows bus signals to switch planes to achieve greater route ability. Up to five simultaneous local/local turns are possible.

The AT40K FPGA core cell is a highly configurable logic block based around two 3-input LUTs (8 x 1 ROM), which can be combined to produce one 4-input LUT. This means that any core cell can implement two functions of three inputs or one function of four inputs. There is a Set/Reset D flip-flop in every cell, the output of which may be tri-stated and fed back internally within the core cell. There is also a 2-to-1 multiplexer in every cell, and an upstream AND gate in the “front end” of the cell. This AND gate is an important feature in the implementation of efficient array multipliers.

With this functionality in each core cell, the core cell can be configured in several modes. The core cell flexibility makes the AT40K architecture well suited to most digital design application areas, see Figure 5-2.

Figure 5-1. The Cell

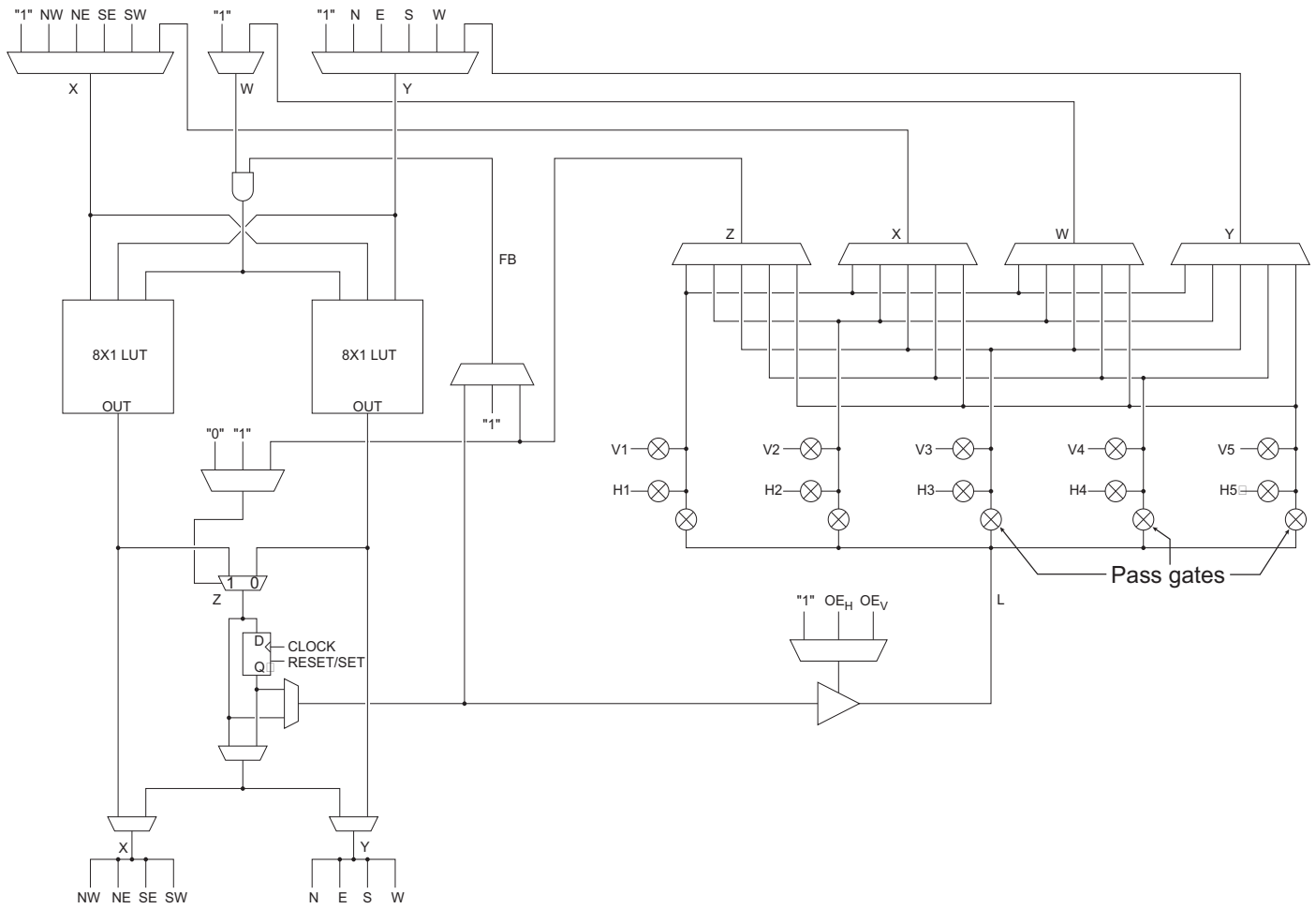

- X = Diagonal Direct Connect or Bus
- Y = Orthogonal Direct Connect or Bus
- W = Bus Connection
- Z = Bus Connection
- FB = Internal Feedback

Figure 5-2. Some Single Cell Modes

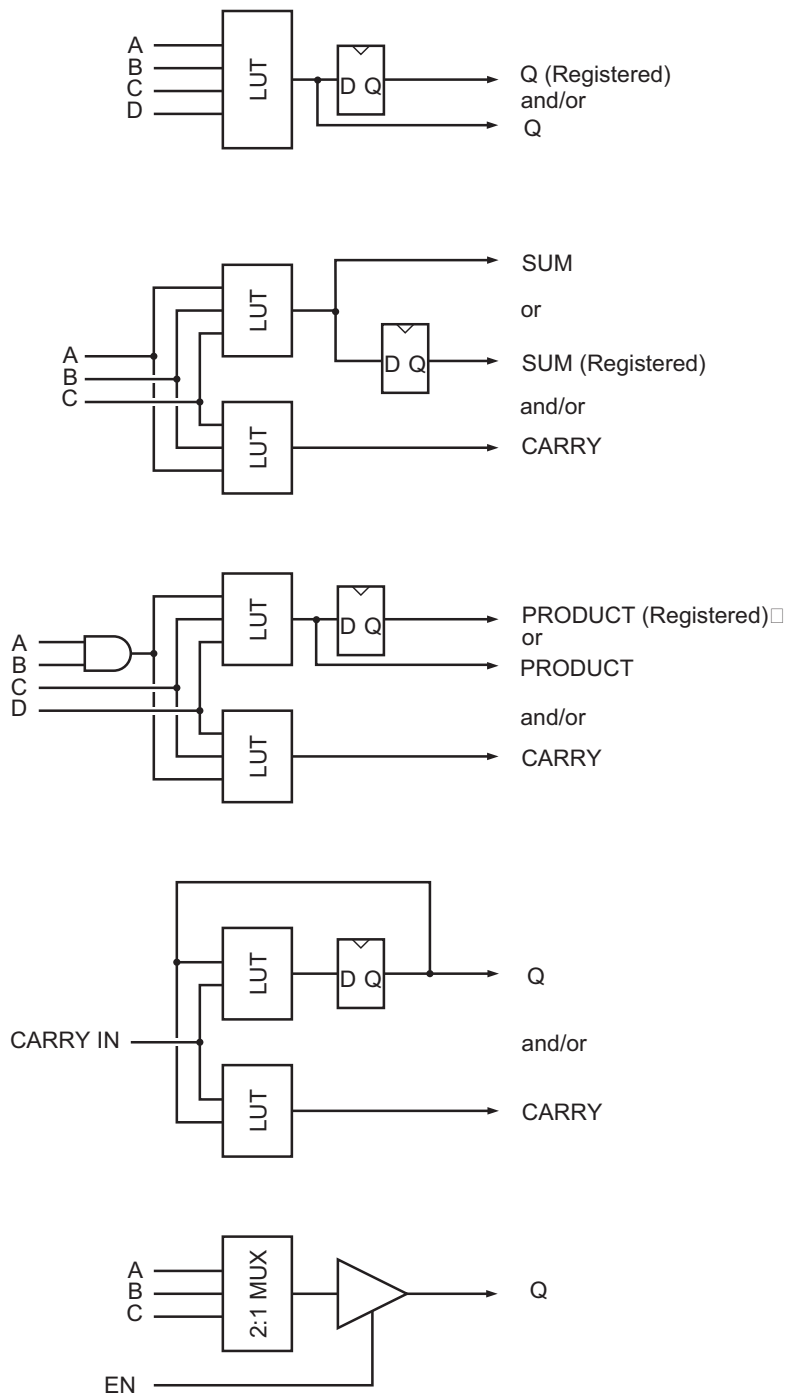

Synthesis Mode. This mode is particularly important for the use of VHDL/Verilog design. VHDL/Verilog Synthesis tools generally will produce as their output large amounts of random logic functions. Having a 4-input LUT structure gives efficient random logic optimization without the delays associated with larger LUT structures. The output of any cell may be registered, tri-stated and/or fed back into a core cell.

Arithmetic Mode is frequently used in many designs. As can be seen in the figure, the AT40K core cell can implement a 1-bit full adder (2-input adder with both Carry In and Carry Out) in one core cell. Note that the sum output in this diagram is registered. This output could then be tri-stated and/or fed back into the cell.

DSP/Multiplier Mode. This mode is used to efficiently implement array multipliers. An array multiplier is an array of bitwise multipliers, each implemented as a full adder with an upstream AND gate. Using this AND gate and the diagonal interconnects between cells, the array multiplier structure fits very well into the AT40K architecture.

Counter Mode. Counters are fundamental to almost all digital designs. They are the basis of state machines, timing chains and clock dividers. A counter is essentially an increment by one function (i.e., an adder), with the input being an output (or a decode of an output) from the previous stage. A 1-bit counter can be implemented in one core cell. Again, the output can be registered, tri-stated and/or fed back.

Tri-state/Mux Mode. This mode is used in many telecommunications applications, where data needs to be routed through more than one possible path. The output of the core cell is very often tri-statable for many inputs to many outputs data switching.

6. RAM

32 x 4 dual-ported RAM blocks are dispersed throughout the array, see [Figure 6-1](#). A 4-bit Input Data Bus connects to four horizontal local buses distributed over four sector rows (Plane 1). A 4-bit Output Data Bus connects to four horizontal local buses distributed over four sectors in the same column. A 5-bit Output Address Bus connects to five vertical express buses in the same column. Ain (input address) and Aout (output address) alternate positions in horizontally aligned RAM blocks. For the left-most RAM blocks, Aout is on the left and Ain is on the right. For the right-most RAM blocks, Ain is on the left and Aout is tied off, thus it can only be configured as a single port. For single-ported RAM, Ain is the READ/WRITE address port and Din is the (bi-directional) data port. Right-most RAM blocks can be used only for single-ported memories. WEN and OEN connect to the vertical express buses in the same column.

Figure 6-1. RAM Connections (One Ram Block)

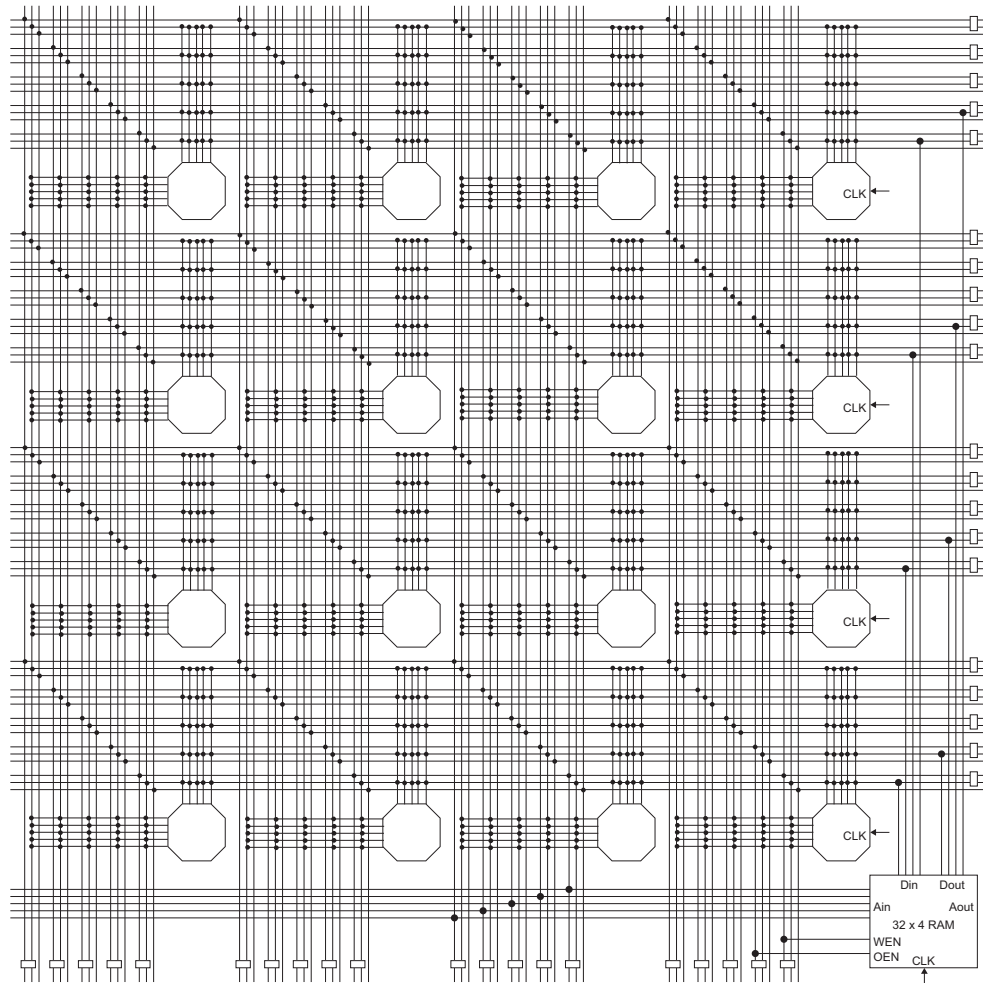

Reading and writing of the 10ns 32 x 4 dual-port FreeRAM are independent of each other. Reading the 32 x 4 dual-port RAM is completely asynchronous. Latches are transparent; when Load is Logic 1, data flows through; when Load is Logic 0, data is latched. These latches are used to synchronize Write Address, Write Enable Not, and Din signals for a synchronous RAM. Each bit in the 32 x 4 dual-port RAM is also a transparent latch. The front-end latch and the memory latch together form an edge-triggered flip flop. When a nibble (bit = 7) is (Write) addressed and LOAD is Logic 1 and \overline{WE} is Logic 0, data flows through the bit. When a nibble is not (Write) addressed or LOAD is logic 0 or \overline{WE} is Logic 1, data is latched in the nibble. The two CLOCK muxes are controlled together; they both select CLOCK (for a synchronous RAM) or they both select "1" (for an asynchronous RAM). CLOCK is obtained from the clock for the sector-column immediately to the left and immediately above the RAM block. Writing any value to the RAM clear byte during configuration clears the RAM (see the "AT40K Configuration Series" application note at www.atmel.com).

Figure 6-2. RAM Logic

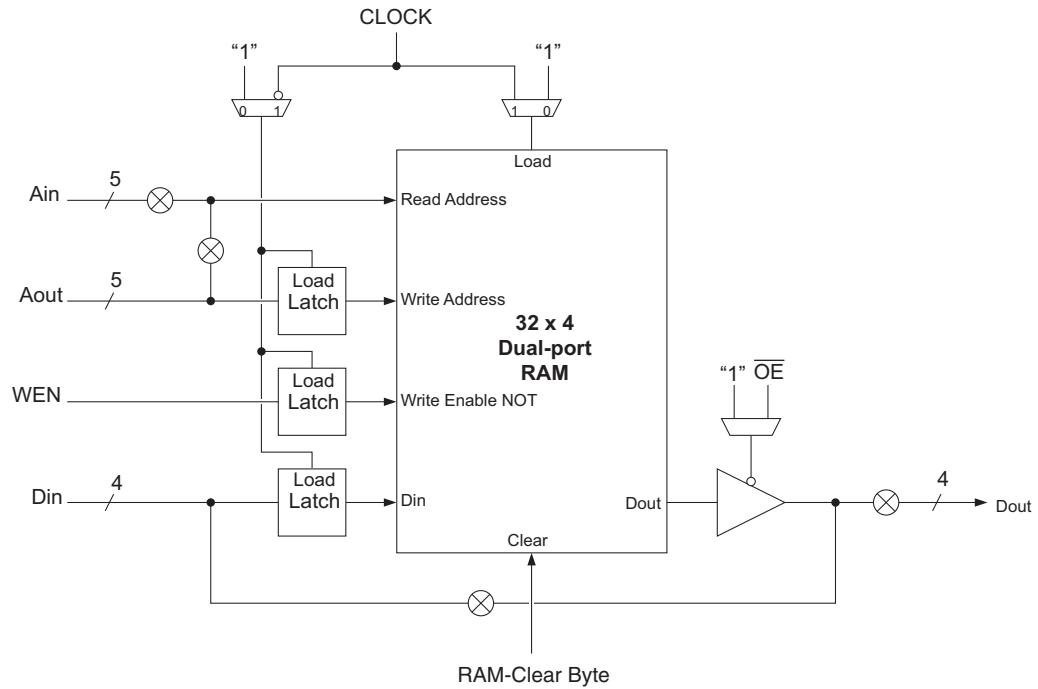
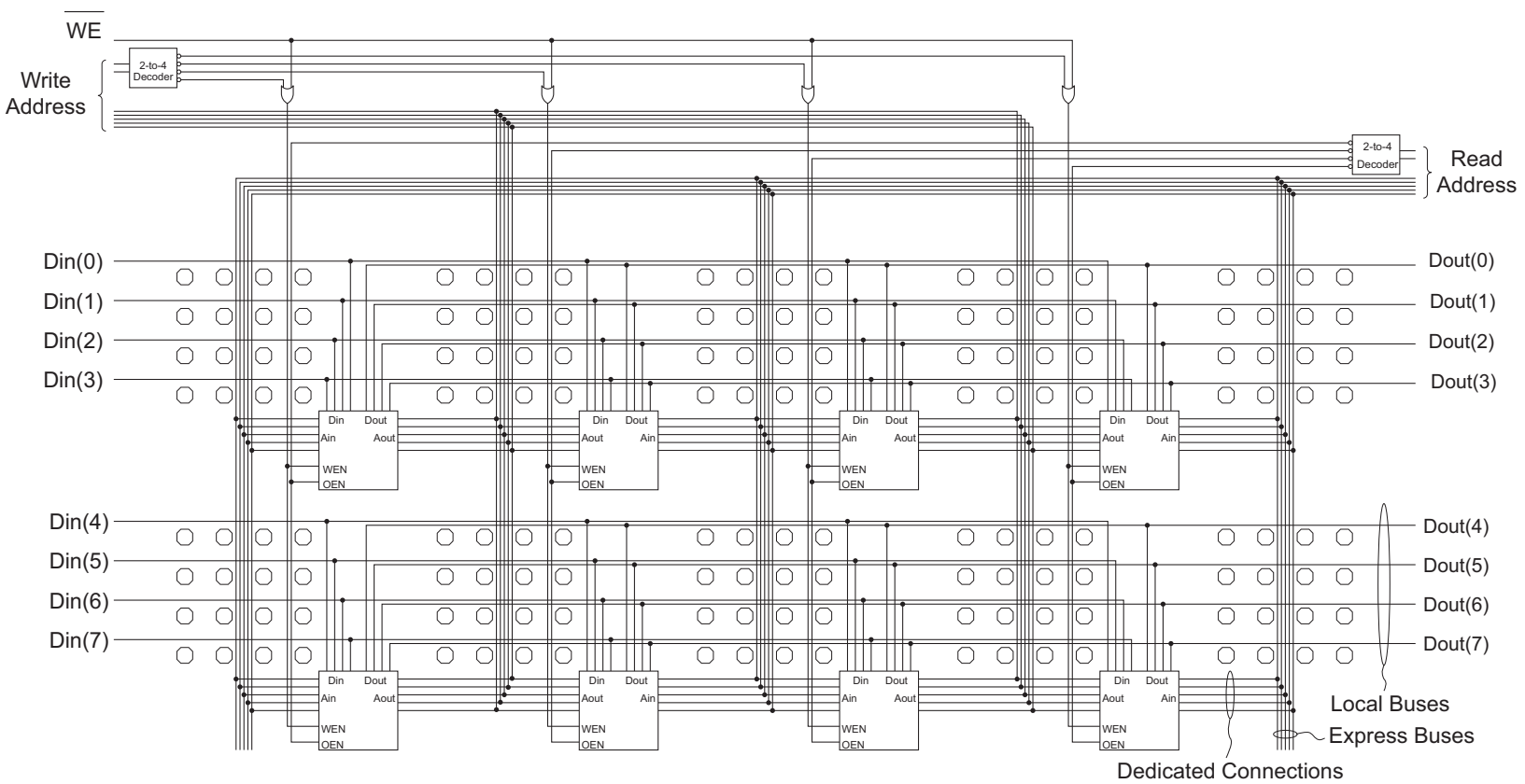

Figure 6-3 shows an example of a RAM macro constructed using the AT40K's FreeRAM cells. The macro shown is a 128 x 8 dual-ported asynchronous RAM. Note the very small amount of external logic required to complete the address decoding for the macro. Most of the logic cells (core cells) in the sectors occupied by the RAM will be unused: they can be used for other logic in the design. This logic can be automatically generated using the macro generators.

Figure 6-3. RAM Example: 128 x 8 Dual-ported RAM (Asynchronous)



7. Clocking Scheme

There are eight Global Clock buses (GCK1 – GCK8) on the AT40K FPGA. Each of the eight dedicated Global Clock buses is connected to one of the dual-use Global Clock pins. Any clocks used in the design should use global clocks where possible: this can be done by using Assign Pin Locks to lock the clocks to the Global Clock locations. In addition to the eight Global Clocks, there are four Fast Clocks (FCK1 – FCK4), two per edge column of the array for PCI specification.

Each column of an array has a “Column Clock mux” and a “Sector Clock mux”. The Column Clock mux is at the top of every column of an array and the Sector Clock mux is at every four cells. The Column Clock mux is selected from one of the eight Global Clock buses. The clock provided to each sector column of four cells is inverted, non-inverted or tied off to “0”, using the Sector Clock mux to minimize the power consumption in a sector that has no clocks. The clock can either come from the Column Clock or from the Plane 4 express bus, see [Figure 7-1](#). The extreme-left Column Clock mux has two additional inputs, FCK1 and FCK2, to provide fast clocking to left-side I/Os. The extreme-right Column Clock mux has two additional inputs as well, FCK3 and FCK4, to provide fast clocking to right-side I/Os.

The register in each cell is triggered on a rising clock edge by default. Before configuration on power-up, constant “0” is provided to each register’s clock pins. After configuration on power-up, the registers either set or reset, depending on the user’s choice.

The clocking scheme is designed to allow efficient use of multiple clocks with low clock skew, both within a column and across the core cell array.

Figure 7-1. Clocking (for One Column of Cells)

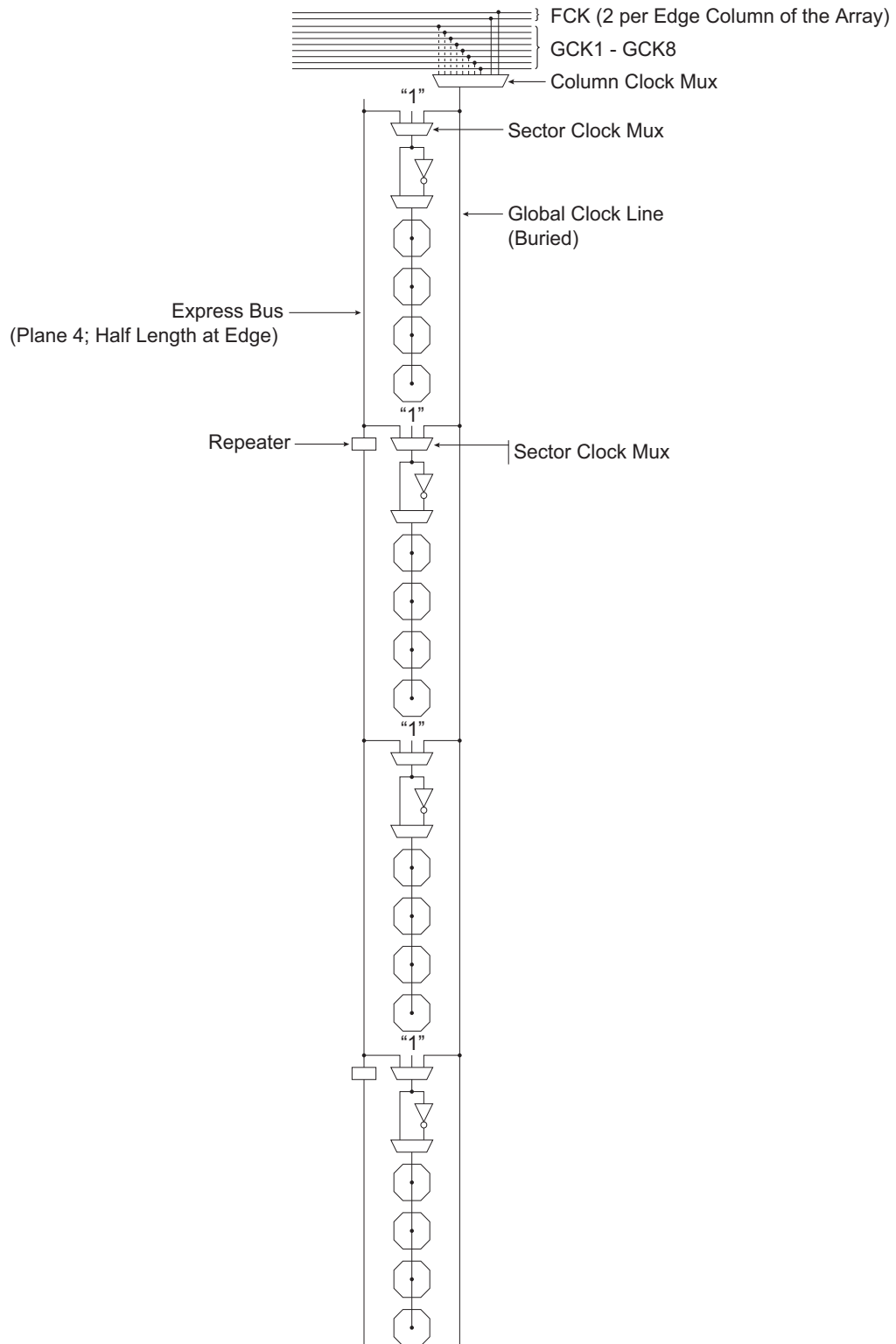

8. Set/Reset Scheme

The AT40K family reset scheme is essentially the same as the clock scheme except that there is only one Global Reset. A dedicated Global Set/Reset bus can be driven by any User I/O, except those used for clocking (Global Clocks or Fast Clocks). The automatic placement tool will choose the reset net with the most connections to use the global resources. You can change this by using an RSBUF component in your design to indicate the global reset. Additional resets will use the express bus network.

The Global Set/Reset is distributed to each column of the array. Like Sector Clock mux, there is Sector Set/Reset mux at every four cells. Each sector column of four cells is set/reset by a Plane 5 express bus or Global Set/Reset using the Sector Set/Reset mux, see [Figure 8-1](#). The set/reset provided to each sector column of four cells is either inverted or non-inverted using the Sector Reset mux.

The function of the Set/Reset input of a register is determined by a configuration bit in each cell. The Set/Reset input of a register is active low (Logic 0) by default. Setting or Resetting of a register is asynchronous. Before configuration on power-up, a Logic 1 (a high) is provided by each register (i.e., all registers are set at power-up).

Figure 8-1. Set/Reset (for One Column of Cells)

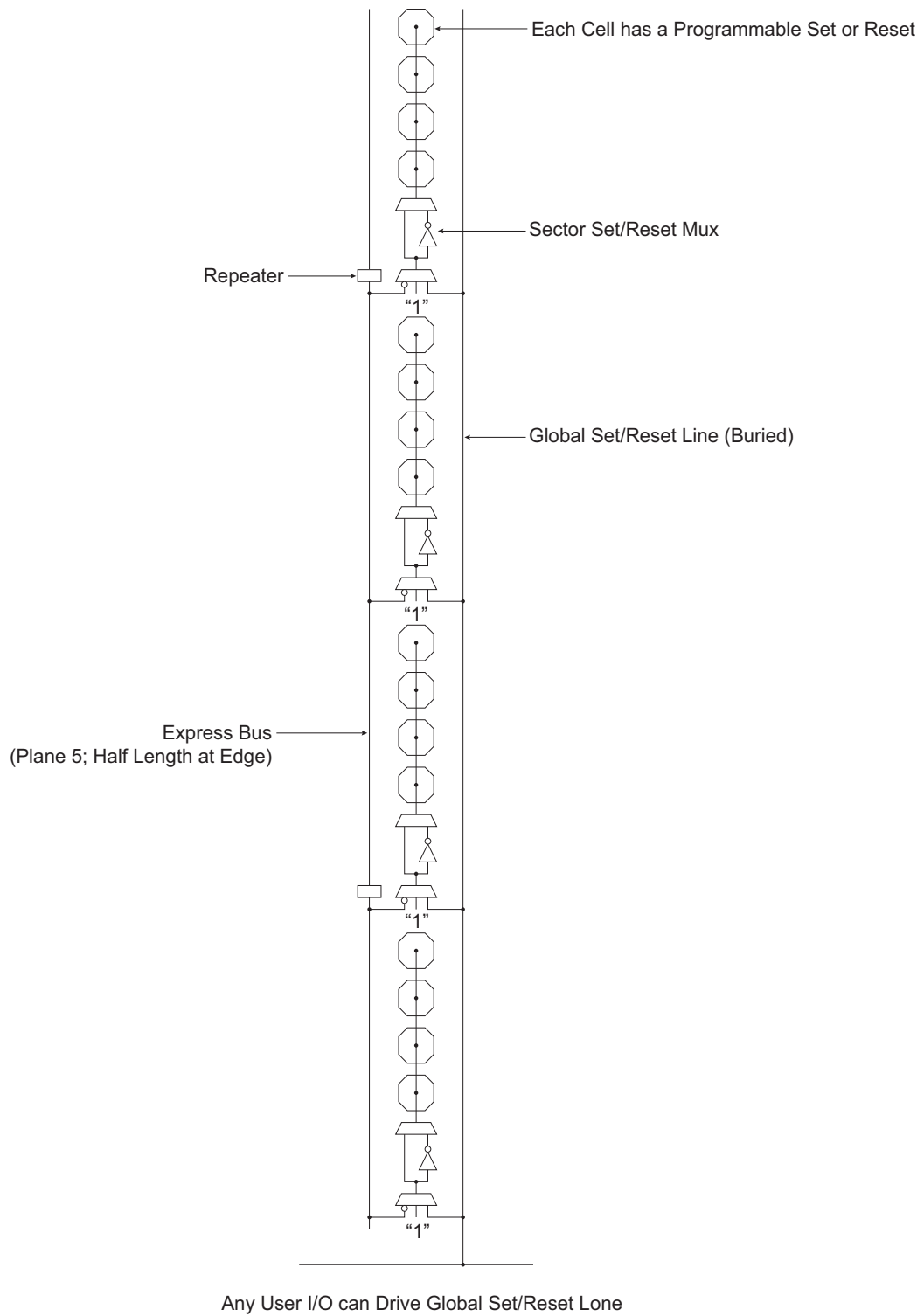

9. I/O Structure

9.1 PAD

The I/O pad is the one that connects the I/O to the outside world. Note that not all I/Os have pads: the ones without pads are called Unbonded I/Os. The number of unbonded I/Os varies with the device size and package. These unbonded I/Os are used to perform a variety of bus turns at the edge of the array.

9.2 PULL-UP/PULL-DOWN

Each pad has a programmable pull-up and pull-down attached to it. This supplies a weak “1” or “0” level to the pad pin. When all other drivers are off, this control will dictate the signal level of the pad pin.

The input stage of each I/O cell has a number of parameters that can be programmed either as properties in schematic entry or in the I/O Pad Attributes editor in IDS.

9.3 TTL/CMOS

The threshold level can be set to either TTL/CMOS-compatible levels.

9.4 SCHMITT

A Schmitt trigger circuit can be enabled on the inputs. The Schmitt trigger is a regenerative comparator circuit that adds 1V hysteresis to the input. This effectively improves the rise and fall times (leading and trailing edges) of the incoming signal and can be useful for filtering out noise.

9.5 DELAYS

The input buffer can be programmed to include four different intrinsic delays as specified in the AC timing characteristics. This feature is useful for meeting data hold requirements for the input signal.

9.6 DRIVE

The output drive capabilities of each I/O are programmable. They can be set to FAST, MEDIUM or SLOW (using IDS tool). The FAST setting has the highest drive capability (20mA at 5V) buffer and the fastest slew rate. MEDIUM produces a medium drive (14mA at 5V) buffer, while SLOW yields a standard (6mA at 5V) buffer.

9.7 TRI-STATE

The output of each I/O can be made tri-state (0, 1, or Z), open source (1 or Z) or open drain (0 or Z) by programming an I/O's Source Selection mux. Of course, the output can be normal (0 or 1), as well.

9.8 SOURCE SELECTION MUX

The Source Selection mux selects the source for the output signal of an I/O, see [Figure 9-1](#).

9.9 Primary, Secondary, and Corner I/Os

The AT40K has three kinds of I/Os: Primary I/O, Secondary I/O and a Corner I/O. Every edge cell except corner cells on the AT40K has access to one Primary I/O and two Secondary I/Os.

9.10 Primary I/O

Every logic cell at the edge of the FPGA array has a direct orthogonal connection to and from a Primary I/O cell. The Primary I/O interfaces directly to its adjacent core cell. It also connects into the repeaters on the row immediately above and below the adjacent core cell. In addition, each Primary I/O also connects into the busing network of the three nearest edge cells. This is an extremely powerful feature, as it provides logic cells toward the center of the array with fast access to I/Os via local and express buses. It can be seen from the diagram that a given Primary I/O can be accessed from any logic cell on three separate rows or columns of the FPGA. See [Figure 9-1](#) and [Figure 9-2](#).

9.11 Secondary I/O

Every logic cell at the edge of the FPGA array has two direct diagonal connections to a Secondary I/O cell. The Secondary I/O is located between core cell locations. This I/O connects on the diagonal inputs to the cell above and the cell below. It also connects to the repeater of the cell above and below. In addition, each Secondary I/O also connects into the busing network of the two nearest edge cells. This is an extremely powerful feature, as it provides logic cells toward the center of the array with fast access to I/Os via local and express buses. It can be seen from the diagram that a given Secondary I/O can be accessed from any logic cell on two rows or columns of the FPGA. See [Figure 9-1](#) and [Figure 9-2](#).

9.12 Corner I/O

Logic cells at the corner of the FPGA array have direct-connect access to five separate I/Os:

- Two Primary
- Two Secondary
- One Corner I/O

Corner I/Os are like an extra Secondary I/O at each corner of the array. With the inclusion of Corner I/Os, an AT40K FPGA with $n \times n$ core cells always has $8n$ I/Os. As the diagram shows, Corner I/Os can be accessed both from the corner logic cell and the horizontal and vertical busing networks running along the edges of the array. This means that many different edge logic cells can access the Corner I/Os. See [Figure 9-3](#).

Figure 9-1. West I/O (Mirrored for East I/O) AT40K

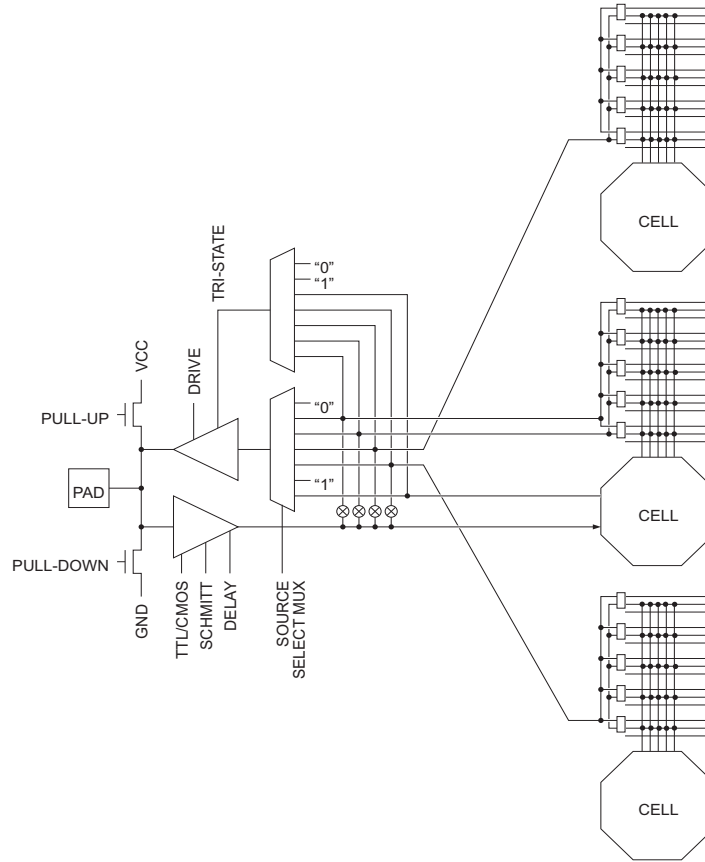

(a) Primary I/O

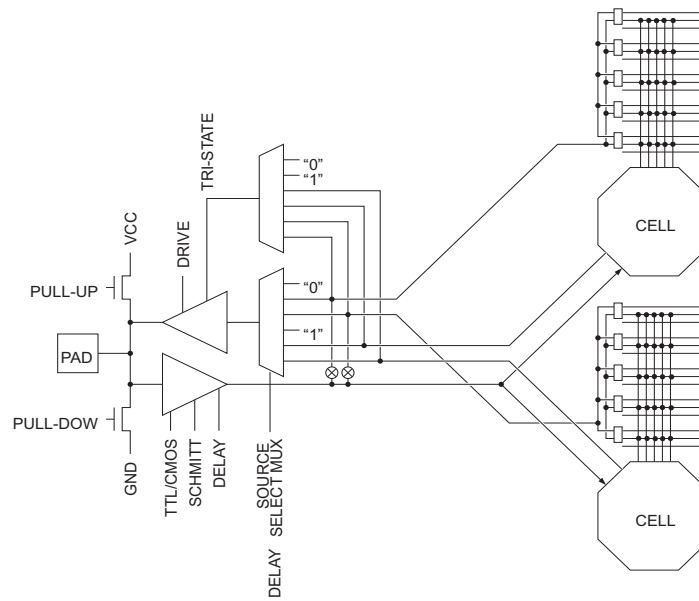

(b) Secondary I/O

Figure 9-2. South I/O (Mirrored for North I/O) AT40K

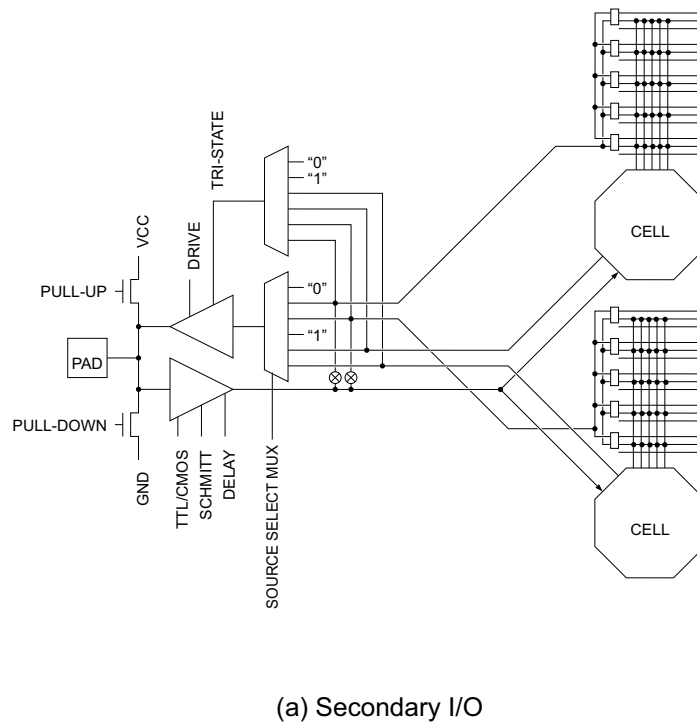
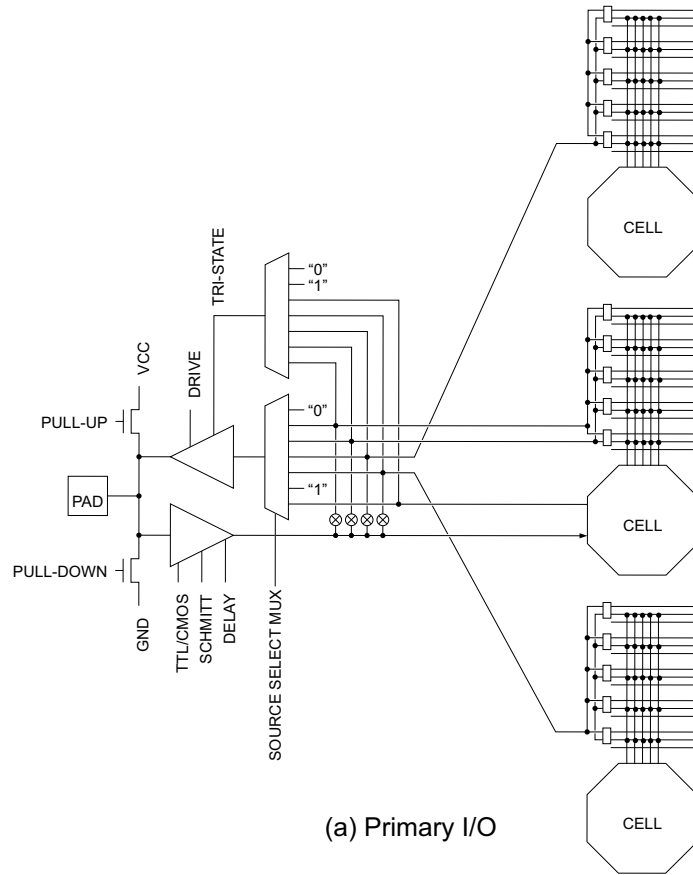
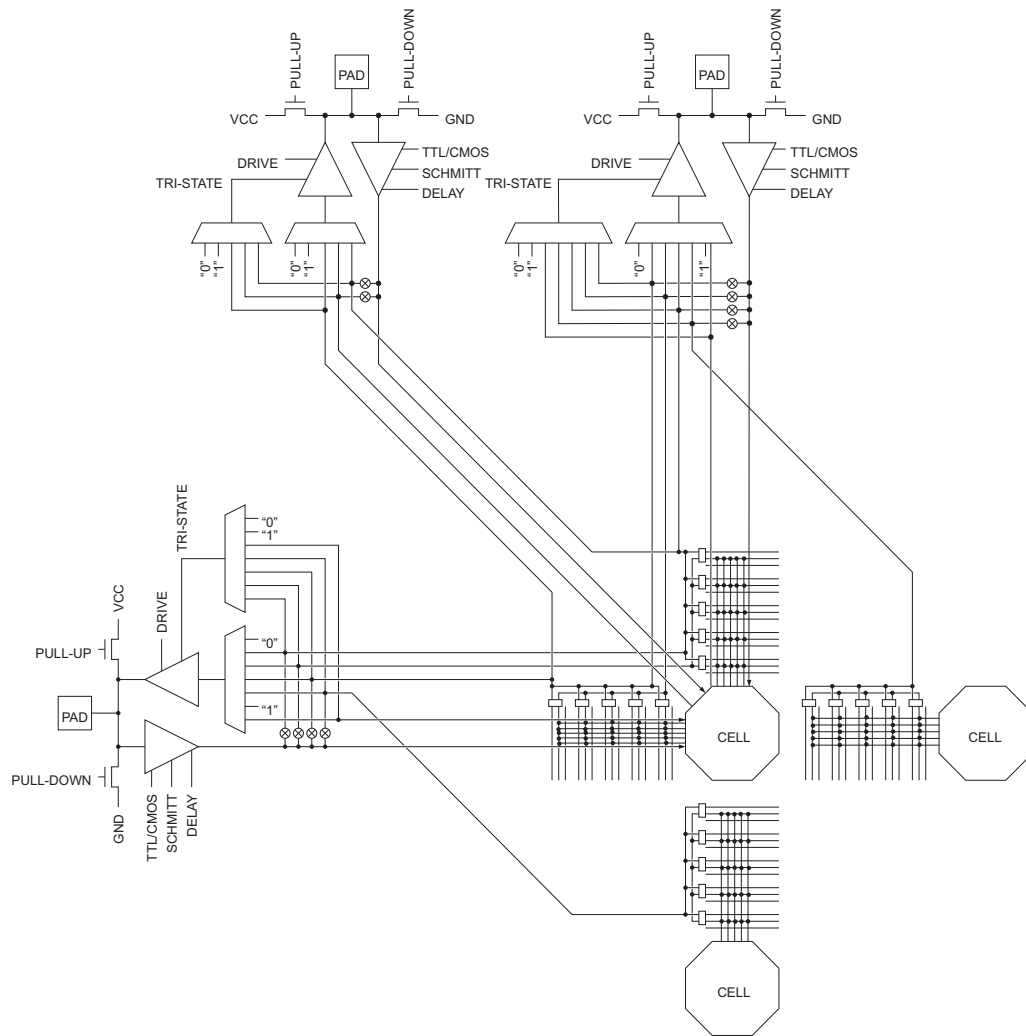

Figure 9-3. Northwest Corner (Similar for NE/SE/SW Corners) AT40K



10. Electrical Specifications

10.1 Absolute Maximum Ratings — 5V Commercial/Industrial* AT40K

Operating Temperature	-55°C to 125°C
Storage Temperature	-65°C to 150°C
Voltage on Any Pin with Respect to Ground	-0.5V to V_{CC} 7.0V
Supply Voltage (V_{CC})	-0.5V to 7.0V
Maximum Soldering Temp. (10 sec. @ 1/16 in.)	250°C
ESD ($R_{ZAP} = 1.5K$, $C_{ZAP} = 100pF$)	2000V

*Notice: Stresses beyond those listed under Absolute Maximum Ratings may cause permanent damage to the device. This is a stress rating only and functional operation of the device at these or any other conditions beyond those listed under operating conditions is not implied. Exposure to Absolute Maximum Rating conditions for extended periods of time may affect device reliability.

10.2 DC and AC Operating Range — 5V Operation AT40K

		Commercial -2	Industrial -2	Military -2
Operating Temperature (Case)		0°C to 70°C	-40°C to 85°C	-55°C to 125°C
V_{CC} Power Supply		5V ± 5%	5V ± 10%	5V ± 10%
Input Voltage Level (TTL)	High (V_{IHT})	2.0V to V_{CC}	2.0V to V_{CC}	2.0V to V_{CC}
	Low (V_{ILT})	0V to 0.8V	0V to 0.8V	0V to 0.8V
Input Voltage Level (CMOS)	High (V_{IHC})	70% to 100% V_{CC}	70% to 100% V_{CC}	70% to 100% V_{CC}
	Low (V_{ILC})	0 to 30% V_{CC}	0 to 30% V_{CC}	0 to 30% V_{CC}

10.3 DC Characteristics — 5V Operation Commercial/Industrial/Military AT40K

Symbol	Parameter	Conditions	Minimum	Typical	Maximum	Units
V _{IH}	High-level Input Voltage	CMOS	70% V _{CC}			V
		TTL	2.0			V
V _{IL}	Low-level Input Voltage	CMOS	-0.3		30% V _{CC}	V
		TTL	-0.3		0.8	V
V _{OH}	High-level Output Voltage	I _{OH} = 6mA V _{CC} = V _{CC} Minimum	Ind. = 3.15 4.0 Con = 3.325			V
		I _{OH} = 14mA V _{CC} = V _{CC} Minimum	Ind. = 3.15 4.0 Con = 3.325			V
		I _{OH} = 20mA Commercial = 4.75V Industrial/Military = 4.5V	Ind. = 3.15 4.0 Con = 3.325			V
V _{OL}	Low-level Output Voltage	I _{OL} = -6mA Commercial = 4.75V Industrial/Military = 4.5V			0.4	V
		I _{OL} = -14mA Commercial = 4.75V Industrial/Military = 4.5V			0.4	V
		I _{OL} = -20mA Commercial = 4.75V Industrial/Military = 4.5V			0.4	V
I _{IH}	High-level Input Current	V _{IN} = V _{CC} Maximum			10.0	μA
		With pull-down, V _{IN} = V _{CC}	125.0	250.0	500.0	μA
I _{IL}	Low-level Input Current	V _{IN} = V _{SS}	-10.0			μA
		With pull-up, V _{IN} = V _{SS}	CON = -1mA to -250μA	-250.0	CON = -1mA to -250μA	μA
I _{OZH}	High-level Tri-state Output Leakage Current	Without pull-down, V _{IN} = V _{CC}			10.0	μA
		With pull-down, V _{IN} = V _{CC}	125.0	250.0	500.0	μA
I _{OZL}	Low-level Tri-state Output Leakage Current	Without pull-up, V _{IN} = V _{SS} Maximum	-10.0			μA
		With pull-up, V _{IN} = V _{SS} Maximum	-500.0	-250.0	-125.0	μA
I _{CC}	Standby Current Consumption	Standby, unprogrammed		0.6	1.0	mA
C _{IN}	Input Capacitance	All pins			10.0	pF

10.4 AC Timing Characteristics — 5V Operation AT40K

Delays are based on fixed loads and are described in the notes.

Maximum times based on worst case: $V_{CC} = 4.75V$, temperature = $70^{\circ}C$

Minimum times based on best case: $V_{CC} = 5.25V$, temperature = $0^{\circ}C$

Maximum delays are the average of t_{PDLH} and t_{PDHL} .

Cell Function	Parameter	Path	-2	Units	Notes
Core					
2-input Gate	t_{PD} (Maximum)	x/y → x/y	1.8	ns	1 unit load
3-input Gate	t_{PD} (Maximum)	x/y/z → x/y	2.1	ns	1 unit load
3-input Gate	t_{PD} (Maximum)	x/y/w → x/y	2.2	ns	1 unit load
4-input Gate	t_{PD} (Maximum)	x/y/w/z → x/y	2.2	ns	1 unit load
Fast Carry	t_{PD} (Maximum)	y → y	1.4	ns	1 unit load
Fast Carry	t_{PD} (Maximum)	x → y	1.7	ns	1 unit load
Fast Carry	t_{PD} (Maximum)	y → x	1.8	ns	1 unit load
Fast Carry	t_{PD} (Maximum)	x → x	1.5	ns	1 unit load
Fast Carry	t_{PD} (Maximum)	w → y	2.2	ns	1 unit load
Fast Carry	t_{PD} (Maximum)	w → x	2.3	ns	1 unit load
Fast Carry	t_{PD} (Maximum)	z → y	2.3	ns	1 unit load
Fast Carry	t_{PD} (Maximum)	z → x	1.7	ns	1 unit load
DFF	t_{PD} (Maximum)	q → x/y	1.8	ns	1 unit load
DFF	t_{PD} (Maximum)	R → x/y	2.2	ns	1 unit load
DFF	t_{PD} (Maximum)	S → x/y	2.2	ns	1 unit load
DFF	t_{PD} (Maximum)	q → w	1.8	ns	
Incremental -> L	t_{PD} (Maximum)	x/y → L	1.5	ns	1 unit load
Local Output Enable	t_{PZX} (Maximum)	oe → L	1.4	ns	1 unit load
Local Output Enable	t_{PXZ} (Maximum)	oe → L	1.8	ns	