



Chipsmall Limited consists of a professional team with an average of over 10 year of expertise in the distribution of electronic components. Based in Hongkong, we have already established firm and mutual-benefit business relationships with customers from,Europe,America and south Asia,supplying obsolete and hard-to-find components to meet their specific needs.

With the principle of “Quality Parts,Customers Priority,Honest Operation,and Considerate Service”,our business mainly focus on the distribution of electronic components. Line cards we deal with include Microchip,ALPS,ROHM,Xilinx,Pulse,ON,Everlight and Freescale. Main products comprise IC,Modules,Potentiometer,IC Socket,Relay,Connector.Our parts cover such applications as commercial,industrial, and automotives areas.

We are looking forward to setting up business relationship with you and hope to provide you with the best service and solution. Let us make a better world for our industry!



Contact us

Tel: +86-755-8981 8866 Fax: +86-755-8427 6832

Email & Skype: info@chipsmall.com Web: www.chipsmall.com

Address: A1208, Overseas Decoration Building, #122 Zhenhua RD., Futian, Shenzhen, China



Features

- 300 mA/1.9V/2.5V DC to DC Converter
- 80 mA/2.8V Dual-mode LDO Regulator (LDO1)
- 130 mA/2.7V/2.8V LDO Regulator (LDO2)
- 130 mA/2.8V LDO Regulator (LDO3)
- 130 mA/2.8V LDO Regulator (LDO4)
- 10 mA/1.8/2.8V Dual-mode LDO Regulator (LDO5)
- Available in a 5 mm x 5 mm 32-pin QFN or 5 mm x 5 mm 32-ball BGA Package
- Applications: Mobile Phones, Digital Cameras, PDAs, SmartPhones, DECT Phones, Handset Devices

Description

The AT73C212 provides a power management solution for integration of multimedia features in mid-level mobile phone handsets. These features may include a camera module (CMOS or CCD), audio generators for a polyphonic or MP3 ringer, a co-processor for JPEG encoding and an external memory module.

The AT73C212 contains six power supplies: five linear voltage regulators providing output voltage from 1.8V to 2.8V and output current from 10 mA to 130 mA and a DC - DC converter supplying 300 mA from 1.9V or 2.5V.

The device is available in two compact, space-saving package options: 32-ball BGA or 32-pin QFN.



Power Management for Mobiles (PM)

AT73C212



Block Diagram

Figure 1. AT73C212 Block Diagram

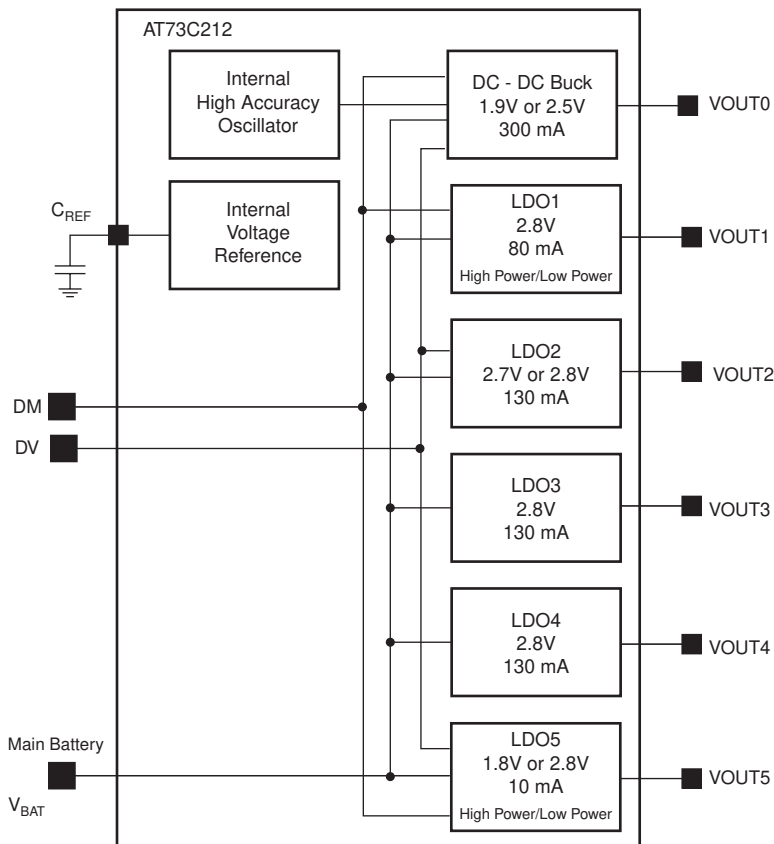

Absolute Maximum Ratings

Storage Temperature	-55°C to +150°C	*NOTICE: Stresses beyond those listed under “Absolute Maximum Ratings” may cause permanent damage to the device. This is a stress rating only and functional operation of the device at these or other conditions beyond those indicated in the operational sections of this specification is not implied. Exposure to absolute maximum rating conditions for extended periods may affect device reliability.
Operating Temperature	-40°C to +85°C	
Power Supply Input	-0.3V to 5.5V	
IO Input (all except power supply)	-0.3 to 2.8V	

Pin List

Table 1. Pin List

Ball	Signal	Type	Description
A1	VOUT4	O	LDO4 output voltage
A2	GNDB	Ground	LDO3 and LDO4 ground
A3	VINC	Supply	LDO3 and LDO4 input supply
A4	GNDD	Ground	Digital ground
A5	VINB	Supply	LDO1 and LDO2 input supply
A6	VINT	O	Decoupling capacitor for internal voltage supply
A7	GNDE	Ground	LDO1 and LDO2 ground
B1	VOUT3	O	LDO3 output voltage
B2	EN3	I	Enable LDO3
B3			Not connected
B4	VOUT2	O	LDO2 output voltage
B5	EN2	I	Enable LDO2
B6	VOUT1	O	LDO1 output voltage
B7			Not connected
C1	GNDF	Ground	Analog ground
C2			Not connected
C3	GNDG	Ground	Analog ground
C4	EN4	I	Enable LDO4
C5	GNDH	Ground	Analog ground
C6	GNDI	Ground	Analog ground
C7	CAP	O	Decoupling capacitor for voltage reference
D1	GNDC	Ground	LDO5 ground
D2			Not connected
D3			Not connected
D4	DV	I	Programmable Voltage Selection
D5	ON	I	Switch on PMU
D6			Not connected
D7	VIND	Supply	LDO5 input supply
E1	VINE	Supply	Battery voltage
E2			Not connected
E3			Not connected
E4			Not connected
E5	GNDL	Ground	Analog ground
E6	EN5	I	Enable LDO5

Table 1. Pin List

Ball	Signal	Type	Description
E7	VOUT5	O	LDO5 output voltage
F1			Not connected
F2			Not connected
F3			Not connected
F4			Not connected
F5			Not connected
F6	Reset	O	PMU start up OK
F7	LX	I	Inductor connection
G1			Not connected
G2			Not connected
G3			Not connected
G4	VOUT0	O	DCDC output voltage
G5	DM	I	Dual power selection
G6	VINA	Supply	DCDC input supply
G7	GNDA	Ground	DCDC ground

DC to DC Electrical Characteristics

$T_{AMB} = -20^{\circ}\text{C}$ to 85°C , $V_{BAT} = 3\text{V}$ to 4.2V unless otherwise specified. $C_{OUT} = 22\mu\text{F}$ - Tantalum - $L_{OUT} = 10\mu\text{H}$

Table 2. DC to DC Electrical Characteristics

Symbol	Parameter	Conditions	Min	Typ	Max	Unit
V_{BAT}	Operating Supply Voltage		3		5.5	V
V_{OUT}	Output Voltage	PWM Mode (DM = 0, DV = 0) Overall accuracy	1.80	1.90	2.0	V
V_{OUT}	Output Voltage	Initial Voltage after Trimming		$1.9 \pm 2\%$		V
V_{OUT}	Output Voltage	PWM Mode (DV = 1, DM = 0)	2.45	2.50	2.55	V
I_{OUT}	Output Current	PWM Mode (DM = 0)		150	300	mA
I_{SD}	Shut Down Current			0.1	1	μA
Eff	Efficiency	$I_{OUT} = 10\text{ mA}$ to 200 mA @ 1.9V	85	90		%
ΔV_{DCLD}	Static Load Regulation	DC - DC Mode (10% to 90% of I_{OUT} max) DM = 0		7		mV
ΔV_{TRLD}	Transient Load Regulation	DC - DC Mode (10% to 90% of I_{OUT} max) $T_R = T_F = 5\text{ us}$; DM = 0		30		mV
ΔV_{DCLE}	Static Line Regulation	DC - DC Mode (10% to 90% of I_{OUT} max, 3.2V to 4.2V) DM = 0		20		mV
ΔV_{TRLE}	Transient Line Regulation	DC - DC Mode (10% to 90% of I_{OUT} max, 3.2V to 4.2V) DM = 0		35		mV
V_{OUT}	Output Voltage	LDO Mode (DV = 0, DM = 1)	1.75	1.80	1.85	V
V_{OUT}	Output Voltage	LDO Mode (DV = 1, DM = 1)	2.35	2.40	2.45	V
I_{OUT}	Output Current	LDO Mode (DM = 1)			10	mA
V_{DROP}	Dropout Voltage	LDO Mode (DM = 1)			400	mV
I_{QC}	Quiescent Current	LDO Mode (DM = 1)		11	14	μA
ΔV_{DCLD}	Static Load Regulation	LDO Mode (0 to 10 mA); DM = 1			50	mV
ΔV_{TRLD}	Transient Load Regulation	LDO Mode (0 to 10 mA), $T_R = T_F = 5\text{ }\mu\text{s}$, DM = 1			10	mV
ΔV_{DCLE}	Static Line Regulation	LDO Mode (3.2V to 4.2V); DM = 1			8	mV
ΔV_{TRLE}	Transient Line Regulation	LDO Mode (3.2V to 4.2V); DM = 1			15	mV
PSRR	Ripple Rejection	LDO Mode up to 1KHz; DM = 1	40	45		dB
ΔV_{LPFP}	Overshoot Voltage	Voltage drop from LDO (LP) to DC - DC (FP)		0	10	mV
ΔV_{FPLP}	Undershoot Voltage	Voltage drop from DC - DC (FP) to LDO (LP)	- 15	0		mV

Table 3. DC to DC External Components

Symbol	Parameter	Conditions	Min	Typ	Max	Unit
C_{OUT}	Output Capacitor Value		17	22	26	μF
C_{ESR}	Output Capacitor ESR				100	mOhm
L_{OUT}	Output Inductor Value		8	10	12	μH
L_{ESR}	Output Inductor ESR	At 100 kHz			1.1	Ohm

LDO1 Electrical Characteristics

$T_{AMB} = -20^{\circ}\text{C}$ to 85°C , $V_{BAT} = 3\text{V}$ to 4.2V unless otherwise specified.

Table 4. LDO1 Electrical Characteristics

Symbol	Parameter	Conditions	Min	Typ	Max	Unit
V_{BAT}	Operating Supply Voltage		3		5.5	V
V_{OUT}	Output Voltage Full Power Mode	DM = 0	2.7	2.8	2.9	V
V_{OUT}	Output Voltage Low Power Mode	DM = 1	2.7	2.8	2.9	V
I_{OUT}	Output Current Full Power Mode	DM = 0		50	80	mA
I_{OUT}	Output Current Low Power Mode	DM = 1			10	mA
I_{QC}	Quiescent Current FP Mode	DM = 0	25	30	36	μA
I_{QC}	Quiescent Current LP Mode	DM = 1	9	11	13	μA
ΔV_{OUT}	Line Regulation FP Mode	$V_{BAT}: 3.4\text{V}$ to 3V , $I_{OUT} = 80\text{ mA}$, DM = 0			1	mV
ΔV_{PEAK}	Line Regulation Transient FP Mode	V_{BAT} : From 5V to 5.4V and from 3.4V to 3V , $I_{OUT} = 80\text{ mA}$, $T_R = T_F = 5\ \mu\text{s}$, DM = 0			2.7	mV
ΔV_{OUT}	Line Regulation LP Mode	$V_{BAT}: 3.4\text{V}$ to 3V , $I_{OUT} = 5\text{ mA}$, DM = 1			2	mV
ΔV_{PEAK}	Line Regulation Transient LP Mode	V_{BAT} : From 5V to 5.4V and from 3.4V to 3V , $I_{OUT} = 5\text{ mA}$, $T_R = T_F = 5\ \mu\text{s}$, DM = 1			4	mV
ΔV_{OUT}	Load Regulation FP Mode	From 0 to 80 mA and from 90% to 10% I_{OUT} , $V_{BAT} = 3.4\text{V}$, DM = 0			2.9 (4.2 at 5.5V)	mV
ΔV_{PEAK}	Load Regulation Transient FP Mode	From 0 to $I_{OUT(MAX)}$ and from 90% to 10% $I_{OUT(MAX)}$, $T_R = T_F = 5\ \mu\text{s}$, $V_{BAT} = 3.4\text{V}$, DM = 0			23	mV
ΔV_{OUT}	Load Regulation LP Mode	From 0 to 80 mA & from 90% to 10% $I_{OUT(MAX)}$, $V_{BAT} = 3.4\text{V}$, DM = 1			5 (7.8 at 5.5V)	mV
PSRR	Ripple Rejection	F = 217 Hz	40	45		dB
V_N	Output Noise FP mode	BW: 10 Hz to 100 kHz			80	μV_{RMS}
V_N	Output Noise LP Mode	BW: 10 Hz to 100 kHz			300	μV_{RMS}
T_R	Rise Time FP	$I_{OUT} = I_{OUT(MAX)}$	70		130	μs
T_R	Rise Time LP	$I_{OUT} = I_{OUT(MAX)}$	50		170	μs
I_{SD}	Shut Down Current				1	μA
I_{SC}	Short Circuit Current		100		130	mA

Table 5. LDO1 External Components

Symbol	Parameter	Conditions	Min	Typ	Max	Unit
C_{OUT}	Output Capacitor Value		1.98	2.2	2.42	μF
C_{ESR}	Output Capacitor ESR	100 kHz			50	mOhm

LDO2 Electrical Characteristics

$T_{AMB} = -20^{\circ}\text{C}$ to 85°C , $V_{BAT} = 3\text{V}$ to 4.2V unless otherwise specified.

Table 6. LDO2 Electrical Characteristics

Symbol	Parameter	Conditions	Min	Typ	Max	Unit
V_{BAT}	Operating Supply Voltage		3		5.5	V
V_{OUT}	Output Voltage	DV = 0	2.65	2.70	2.75	V
V_{OUT}	Output Voltage	DV = 1	2.75	2.80	2.85	V
I_{OUT}	Output Current			80	130	mA
I_{QC}	Quiescent Current			195	236	μA
ΔV_{OUT}	Line Regulation	$V_{BAT}: 3\text{V}$ to 3.4V , $I_{OUT} = 130\text{ mA}$		1	2	mV
ΔV_{PEAK}	Line Regulation Transient	Same as above, $T_R = T_F = 5\ \mu\text{s}$		1.5	2.85	mV
ΔV_{OUT}	Load Regulation	10% - 90% I_{OUT} ; $V_{BAT} = 3\text{V}$			1	mV
		10% - 90% I_{OUT} ; $V_{BAT} = 5.0\text{V}$			1	mV
		10% - 90% I_{OUT} ; $V_{BAT} = 5.5\text{V}$			1	mV
ΔV_{PEAK}	Load Regulation Transient	Same as above, $T_R = T_F = 5\ \mu\text{s}$		1.2	2.4	mV
PSRR	Ripple rejection	$F = 217\text{ Hz}$, $V_{BAT} = 3.6\text{V}$		70	73	dB
V_N	Output Noise	BW: 10 Hz to 100 kHz		29	37	μV_{RMS}
T_R	Rise Time	100% I_{OUT} , 10% - 90% V_{OUT}			50	μs
I_{SD}	Shut Down Current				1	μA

Table 7. LDO2 External Components

Symbol	Parameter	Conditions	Min	Typ	Max	Unit
C_{OUT}	Output Capacitor Value		1.98	2.2	2.42	μF
C_{ESR}	Output Capacitor ESR	100 kHz			50	mOhm

LDO3 Electrical Characteristics

$T_{AMB} = -20^{\circ}\text{C}$ to 85°C , $V_{BAT} = 3\text{V}$ to 4.2V unless otherwise specified.

Table 8. LDO3 Electrical Characteristics

Symbol	Parameter	Conditions	Min	Typ	Max	Unit
V_{BAT}	Operating Supply Voltage		3		5.5	V
V_{OUT}	Output Voltage		2.74	2.8	2.86	V
I_{OUT}	Output Current			80	130	mA
I_{QC}	Quiescent Current			195	236	μA
ΔV_{OUT}	Line Regulation	$V_{BAT}: 3\text{V}$ to 3.4V , $I_{OUT} = 130\text{ mA}$		1	2	mV
ΔV_{PEAK}	Line Regulation Transient	Same as above, $T_R = T_F = 5\ \mu\text{s}$		1.5	2.85	mV
ΔV_{OUT}	Load Regulation	10% - 90% I_{OUT} ; $V_{BAT} = 3\text{V}$			1	mV
		10% - 90% I_{OUT} ; $V_{BAT} = 5.0\text{V}$			1	mV
		10% - 90% I_{OUT} ; $V_{BAT} = 5.5\text{V}$			1	mV
ΔV_{PEAK}	Load Regulation Transient	Same as above, $T_R = T_F = 5\ \mu\text{s}$		1.2	2.4	mV
PSRR	Ripple rejection	$F = 217\text{ Hz}$, $V_{BAT} = 3.6\text{V}$	70	73		dB
V_N	Output Noise	BW: 10 Hz to 100 kHz		29	37	μV_{RMS}
T_R	Rise Time	100% I_{OUT} , 10% - 90% V_{OUT}			50	μs
I_{SD}	Shut Down Current				1	μA

Table 9. LDO3 External Components

Symbol	Parameter	Conditions	Min	Typ	Max	Unit
C_{OUT}	Output Capacitor Value		1.98	2.2	2.42	μF
C_{ESR}	Output Capacitor ESR	100 kHz			50	mOhm

LDO4 Electrical Characteristics

$T_{AMB} = -20^{\circ}\text{C}$ to 85°C , $V_{BAT} = 3\text{V}$ to 4.2V unless otherwise specified.

Table 10. LDO4 Electrical Characteristics

Symbol	Parameter	Conditions	Min	Typ	Max	Unit
V_{BAT}	Operating Supply Voltage		3		5.5	V
V_{OUT}	Output Voltage		2.74	2.8	2.86	V
I_{OUT}	Output Current			80	130	mA
I_{QC}	Quiescent Current			195	236	μA
ΔV_{OUT}	Line Regulation	$V_{BAT}: 3\text{V}$ to 3.4V , $I_{OUT} = 130\text{ mA}$		1	2	mV
ΔV_{PEAK}	Line Regulation Transient	Same as above, $T_R = T_F = 5\ \mu\text{s}$		1.5	2.85	mV
ΔV_{OUT}	Load Regulation	10% - 90% I_{OUT} ; $V_{BAT} = 3\text{V}$			1	mV
		10% - 90% I_{OUT} ; $V_{BAT} = 5.0\text{V}$			1	mV
		10% - 90% I_{OUT} ; $V_{BAT} = 5.5\text{V}$			1	mV
ΔV_{PEAK}	Load Regulation Transient	Same as above, $T_R = T_F = 5\ \mu\text{s}$		1.2	2.4	mV
PSRR	Ripple rejection	$F = 217\text{ Hz}$, $V_{BAT} = 3.6\text{V}$	70	73		dB
V_N	Output Noise	BW: 10 Hz to 100 kHz		29	37	μV_{RMS}
T_R	Rise Time	100% I_{OUT} , 10% - 90% V_{OUT}			50	μs
I_{SD}	Shut Down Current				1	μA

Table 11. LDO4 External Components

Symbol	Parameter	Conditions	Min	Typ	Max	Unit
C_{OUT}	Output Capacitor Value		1.98	2.2	2.42	μF
C_{ESR}	Output Capacitor ESR	100 kHz			50	mOhm

LDO5 Electrical Characteristics

$T_{AMB} = -20^{\circ}\text{C}$ to 85°C , $V_{BAT} = 3\text{V}$ to 4.2V unless otherwise specified.

Table 12. LDO5 Electrical Characteristics

Symbol	Parameter	Conditions	Min	Typ	Max	Unit
V_{BAT}	Operating Supply Voltage		3		5.5	V
V_{OUT}	Output Voltage	$I_{OUT} < 10\text{mA}$, $DV = 0$	1.71	1.8	1.89	V
V_{OUT}	Output Voltage	$I_{OUT} < 10\text{ mA}$, $DV = 1$	2.74	2.8	2.86	V
I_{SD}	Shut Down Current			0.1	1	μA
I_{QC}	Low Power Quiescent Current			8	9.5	μA
I_{OUT}	Output Current			10		mA
I_{SC}	Short Circuit Current				40	mA

Table 13. LDO5 External Components

Symbol	Parameter	Conditions	Min	Typ	Max	Unit
C_{OUT}	Output Capacitor Value		198	220	242	nF
C_{ESR}	Output Capacitor ESR	100 kHz			50	mOhm



Atmel Corporation

2325 Orchard Parkway
San Jose, CA 95131, USA
Tel: 1(408) 441-0311
Fax: 1(408) 487-2600

Regional Headquarters

Europe

Atmel Sarl
Route des Arsenaux 41
Case Postale 80
CH-1705 Fribourg
Switzerland
Tel: (41) 26-426-5555
Fax: (41) 26-426-5500

Asia

Room 1219
Chinachem Golden Plaza
77 Mody Road Tsimshatsui
East Kowloon
Hong Kong
Tel: (852) 2721-9778
Fax: (852) 2722-1369

Japan

9F, Tonetsu Shinkawa Bldg.
1-24-8 Shinkawa
Chuo-ku, Tokyo 104-0033
Japan
Tel: (81) 3-3523-3551
Fax: (81) 3-3523-7581

Atmel Operations

Memory

2325 Orchard Parkway
San Jose, CA 95131, USA
Tel: 1(408) 441-0311
Fax: 1(408) 436-4314

Microcontrollers

2325 Orchard Parkway
San Jose, CA 95131, USA
Tel: 1(408) 441-0311
Fax: 1(408) 436-4314

La Chantrerie
BP 70602
44306 Nantes Cedex 3, France
Tel: (33) 2-40-18-18-18
Fax: (33) 2-40-18-19-60

ASIC/ASSP/Smart Cards

Zone Industrielle
13106 Rousset Cedex, France
Tel: (33) 4-42-53-60-00
Fax: (33) 4-42-53-60-01

1150 East Cheyenne Mtn. Blvd.
Colorado Springs, CO 80906, USA
Tel: 1(719) 576-3300
Fax: 1(719) 540-1759

Scottish Enterprise Technology Park
Maxwell Building
East Kilbride G75 0QR, Scotland
Tel: (44) 1355-803-000
Fax: (44) 1355-242-743

RF/Automotive

Theresienstrasse 2
Postfach 3535
74025 Heilbronn, Germany
Tel: (49) 71-31-67-0
Fax: (49) 71-31-67-2340

1150 East Cheyenne Mtn. Blvd.
Colorado Springs, CO 80906, USA
Tel: 1(719) 576-3300
Fax: 1(719) 540-1759

Biometrics/Imaging/Hi-Rel MPU/ High Speed Converters/RF Datacom

Avenue de Rochepleine
BP 123
38521 Saint-Egreve Cedex, France
Tel: (33) 4-76-58-30-00
Fax: (33) 4-76-58-34-80

Literature Requests

www.atmel.com/literature

Disclaimer: Atmel Corporation makes no warranty for the use of its products, other than those expressly contained in the Company's standard warranty which is detailed in Atmel's Terms and Conditions located on the Company's web site. The Company assumes no responsibility for any errors which may appear in this document, reserves the right to change devices or specifications detailed herein at any time without notice, and does not make any commitment to update the information contained herein. No licenses to patents or other intellectual property of Atmel are granted by the Company in connection with the sale of Atmel products, expressly or by implication. Atmel's products are not authorized for use as critical components in life support devices or systems.

© Atmel Corporation 2004. All rights reserved. Atmel® and combinations thereof are the registered trademarks of Atmel Corporation or its subsidiaries. Other terms and product names may be the trademarks of others.



Printed on recycled paper.

2743A-PMGMT-05/04