



Chipsmall Limited consists of a professional team with an average of over 10 year of expertise in the distribution of electronic components. Based in Hongkong, we have already established firm and mutual-benefit business relationships with customers from,Europe,America and south Asia,supplying obsolete and hard-to-find components to meet their specific needs.

With the principle of “Quality Parts,Customers Priority,Honest Operation,and Considerate Service”,our business mainly focus on the distribution of electronic components. Line cards we deal with include Microchip,ALPS,ROHM,Xilinx,Pulse,ON,Everlight and Freescale. Main products comprise IC,Modules,Potentiometer,IC Socket,Relay,Connector.Our parts cover such applications as commercial,industrial, and automotives areas.

We are looking forward to setting up business relationship with you and hope to provide you with the best service and solution. Let us make a better world for our industry!



Contact us

Tel: +86-755-8981 8866 Fax: +86-755-8427 6832

Email & Skype: info@chipsmall.com Web: www.chipsmall.com

Address: A1208, Overseas Decoration Building, #122 Zhenhua RD., Futian, Shenzhen, China



Features

- Smart Card Interface
 - Compliance with Standards
 - ISO/IEC 7816-1, 2, 3 and 4
 - EMV 2000
 - CB
 - Mondex®, Proton, ZKA, Other: Contact Gemplus®
 - Supported Smart Cards
 - Number of Smart Cards Supported: 1
 - Asynchronous Cards: T=0 and T=1
 - Synchronous/Memory Cards Using a Command Interpreter
 - EMV or Non EMV Cards
- Electrical Interface
 - Transmission Speed: 9.6 Kbps to 115 Kbps
 - Card Power Supply: 1.8V/3V/5V
 - ESD Protection On Card Pins: 4 KV - Human Body Model
 - Card Presence or Insertion Detection
 - Short Circuit Current Limitation
- Host Interface
 - Physical Layer
 - Serial Asynchronous Link
 - Programmable Transmission Speed From 1,200 bps to 115,200 bps
 - Format: 8 bits, No Parity, 1 Stop Bit
 - Adjustable Signal Voltage
 - Protocol
 - Gemplus Block Protocol (GBP)
 - GBP Interface Library Kit Source Code
- Chip Power Supply
 - Voltage: V_{CC} - 2.85V to 5.4V
 - Consumption: 8 mA Typical, 150 mA Max - Smart Card Powered
 - Power Down Mode
 - 100 μ A Max Power Down Current
 - Power-down/Power-up by Host Command
- Additional Features
 - Operating Temperature Range: 0°C to +70°C (-40°C to +85°C)
 - Package: SS0P24
 - LED Management: The LED is On When the Card is Powered On

Description

AT83C21GC is designed to simplify the integration of smart card interfaces in electronic devices.

It manages the electrical interface and communication with ISO 7816 –1/2/3/4 compatible smart cards and memory cards.

Figure 1. Basic Architecture of a Smart Card Reader

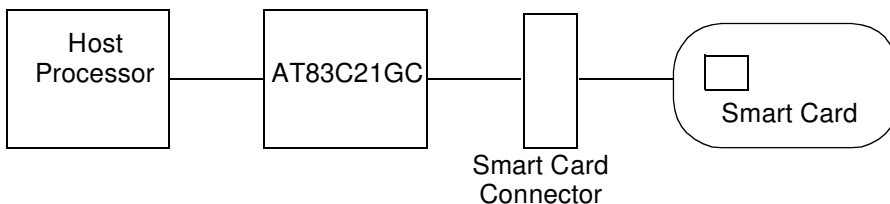

GemCore Serial Lite PRO

AT83C21GC

Summary

Rev. 4247BS-SCR-05/04



This is a summary Document. A complete document is available on the Gemplus Web site. www.gemplus.com



The connection with the host processor is achieved via a serial asynchronous link; the rate can be selected from a range from 1200 to 115,200 bps.

The software inside the GemCore chip handles a communication protocol with the host system called the Gemplus Block Protocol (GBP).

A complete set of documentation is available on the Gemplus web site: <http://www.gemplus.com>.

A GBP Interface Library Kit can be provided, upon request. It consists of the source code of the GBP communication layer between the host and GemCore. It is written in the C language. See the Gemplus developers' site at www.gemplus.com. Enquiries can also be posted to cardreader@atmel.com.

Ordering information

Part Number	Temperature Range	Package	Packing
AT83C21GCxxx-ICSIL	Industrial	SSOP24	Stick
AT83C21GCxxx-ICRIL	Industrial	SSOP24	Tape & Reel

xxx : Firmware version

Pin Description

Figure 2. 24-pin SSOP Pinout

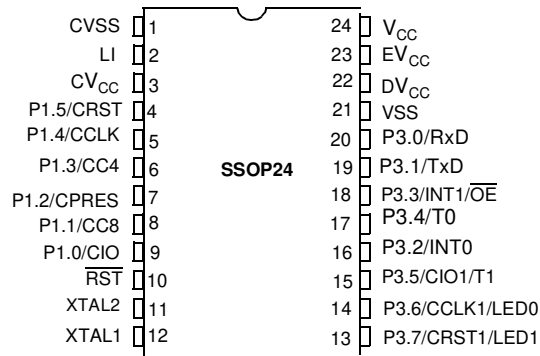

Table 1. Port Signal Description

Port	Signal Name	Internal Power Supply	ESD	Type	Description
P1.0	CIO	CV _{CC}	4 kV	I/O	Smart Card Interface Function Card I/O – Pull-up medium is lower than 20KΩ
P1.1	CC8	CV _{CC}	4 kV	I/O	Smart Card Interface Function Card contact 8 – Pull-up medium must be less than 20KΩ
P1.2	CPRES	V _{CC}	4 kV	I	Smart Card Interface Function Card presence
P1.3	CC4	CV _{CC}	4 kV	I/O	Smart Card Interface Function Card contact 4 – Pull-up medium must be less than 20KΩ
P1.4	CCLK	CV _{CC}	4 kV	O	Smart Card Interface Function Card clock
P1.5	CRST	CV _{CC}	4 kV	O	Smart Card Interface Function Card reset – Pull-up medium must be less than 20KΩ
P3.0	RxD	EV _{CC}		I	UART Function Receive data input
P3.1	TxD	EV _{CC}		O	UART Function Transmit data output.
P3.2	INT0	DV _{CC}		I/O	Input/Output Function P3.2 is a bi-directional I/O port with internal pull-ups.
P3.3	INT1	EV _{CC}		I/O	Input/Output Function P3.3 is a bi-directional I/O port with internal pull-ups.
P3.4		EV _{CC}		I/O	Input/Output Function P3.4 is a bi-directional I/O port with internal pull-ups.
P3.5	CIO1	DV _{CC}		I/O	Alternate Card Function Card I/O: Pull-up medium must be less than 20K

Table 1. Port Signal Description (Continued)

Port	Signal Name	Internal Power Supply	ESD	Type	Description
P3.6	CCLK1	DV _{CC}		O	LED function These pins can be directly connected to the cathode of the standard LED without external current limiting resistors. The typical current of each output can be programmed by software to 2, 4 or 10 mA (LEDCON register).
P3.7	CRST1	DV _{CC}		I/O	Input/Output Function P3.7 is a bi-directional I/O port with internal pull-ups.
RST		V _{CC}		I/O	Reset Input Holding this pin low for 64 oscillator periods while the oscillator is running resets the device. The Port pins are driven to their reset conditions when a voltage lower than V _{IL} is applied, whether or not the oscillator is running. This pin has an internal pull-up resistor which allows the device to be reset by connecting a capacitor between this pin and VSS. Asserting $\overline{\text{RST}}$ when the chip is in Idle mode or Power-down mode returns the chip to normal operation. The output is active for at least 12 oscillator periods when an internal reset occurs.
XTAL1		V _{CC}		I	Input to the on-chip Inverting Oscillator Amplifier To use the internal oscillator, a crystal/resonator circuit is connected to this pin. If an external oscillator is used, its output is connected to this pin.
XTAL2		V _{CC}		O	Output of the on-chip Inverting Oscillator Amplifier To use the internal oscillator, a crystal/resonator circuit is connected to this pin. If an external oscillator is used, XTAL2 may be left unconnected.
V _{CC}				PWR	Supply Voltage V _{CC} is used to power the internal voltage regulators and internal I/O's.
LI				PWR	DC/DC Input LI must be tied to V _{CC} through an external coil (typically 4, 7 μH) and provide the current for the pump charge of the DC/DC converter.
CV _{CC}				PWR	Card Supply Voltage CV _{CC} is the programmable voltage output for the Card interface. It must be connected to an external decoupling capacitor.
DV _{CC}				PWR	Digital Supply Voltage DV _{CC} is used to supply the digital core and internal I/Os. It is internally connected to the output of a 3V regulator and must be connected to an external decoupling capacitor.
EV _{CC}		V _{CC}		PWR	Extra Supply Voltage EV _{CC} is used to supply the level shifters of UART interface I/O pins. It must be connected to an external decoupling capacitor. This reference voltage is generated internally (automatically or not), or it can be connected to an external voltage reference.
CVSS				GND	DC/DC Ground CVSS is used to sink high shunt currents from the external coil.
VSS				GND	Ground



Atmel Headquarters

Corporate Headquarters

2325 Orchard Parkway
San Jose, CA 95131
TEL 1(408) 441-0311
FAX 1(408) 487-2600

Europe

Atmel Sarl
Route des Arsenaux 41
Case Postale 80
CH-1705 Fribourg
Switzerland
TEL (41) 26-426-5555
FAX (41) 26-426-5500

Asia

Room 1219
Chinachem Golden Plaza
77 Mody Road Tsimhatsui
East Kowloon
Hong Kong
TEL (852) 2721-9778
FAX (852) 2722-1369

Japan

9F, Tonetsu Shinkawa Bldg.
1-24-8 Shinkawa
Chuo-ku, Tokyo 104-0033
Japan
TEL (81) 3-3523-3551
FAX (81) 3-3523-7581

Atmel Operations

Memory

2325 Orchard Parkway
San Jose, CA 95131
TEL 1(408) 441-0311
FAX 1(408) 436-4314

Microcontrollers

2325 Orchard Parkway
San Jose, CA 95131
TEL 1(408) 441-0311
FAX 1(408) 436-4314

La Chantrerie
BP 70602
44306 Nantes Cedex 3, France
TEL (33) 2-40-18-18-18
FAX (33) 2-40-18-19-60

ASIC/ASSP/Smart Cards

Zone Industrielle
13106 Rousset Cedex, France
TEL (33) 4-42-53-60-00
FAX (33) 4-42-53-60-01

1150 East Cheyenne Mtn. Blvd.
Colorado Springs, CO 80906
TEL 1(719) 576-3300
FAX 1(719) 540-1759

Scottish Enterprise Technology Park
Maxwell Building
East Kilbride G75 0QR, Scotland
TEL (44) 1355-803-000
FAX (44) 1355-242-743

RF/Automotive

Theresienstrasse 2
Postfach 3535
74025 Heilbronn, Germany
TEL (49) 71-31-67-0
FAX (49) 71-31-67-2340

1150 East Cheyenne Mtn. Blvd.
Colorado Springs, CO 80906
TEL 1(719) 576-3300
FAX 1(719) 540-1759

Biometrics/Imaging/Hi-Rel MPU/ High Speed Converters/RF Data- com

Avenue de Rochepleine
BP 123
38521 Saint-Egreve Cedex, France
TEL (33) 4-76-58-30-00
FAX (33) 4-76-58-34-80

e-mail

literature@atmel.com

Web Site

<http://www.atmel.com>

Disclaimer: Atmel Corporation makes no warranty for the use of its products, other than those expressly contained in the Company's standard warranty which is detailed in Atmel's Terms and Conditions located on the Company's web site. The Company assumes no responsibility for any errors which may appear in this document, reserves the right to change devices or specifications detailed herein at any time without notice, and does not make any commitment to update the information contained herein. No licenses to patents or other intellectual property of Atmel are granted by the Company in connection with the sale of Atmel products, expressly or by implication. Atmel's products are not authorized for use as critical components in life support devices or systems.

© **Atmel Corporation 2004**. All rights reserved. Atmel, the Atmel logo, and combinations thereof are registered trademarks of Atmel Corporation or its subsidiaries. Gemplus is a registered trademark of Gemplus. Mondex is a registered trademark of Mondex International Limited.

Other terms and product names in this document may be the trademarks of others.



Printed on recycled paper.