



Chipsmall Limited consists of a professional team with an average of over 10 year of expertise in the distribution of electronic components. Based in Hongkong, we have already established firm and mutual-benefit business relationships with customers from,Europe,America and south Asia,supplying obsolete and hard-to-find components to meet their specific needs.

With the principle of “Quality Parts,Customers Priority,Honest Operation,and Considerate Service”,our business mainly focus on the distribution of electronic components. Line cards we deal with include Microchip,ALPS,ROHM,Xilinx,Pulse,ON,Everlight and Freescale. Main products comprise IC,Modules,Potentiometer,IC Socket,Relay,Connector.Our parts cover such applications as commercial,industrial, and automotives areas.

We are looking forward to setting up business relationship with you and hope to provide you with the best service and solution. Let us make a better world for our industry!



Contact us

Tel: +86-755-8981 8866 Fax: +86-755-8427 6832

Email & Skype: info@chipsmall.com Web: www.chipsmall.com

Address: A1208, Overseas Decoration Building, #122 Zhenhua RD., Futian, Shenzhen, China



AT90USBKey

.....
Hardware User Guide





Section 1

Introduction	1-3
1.1 Overview	1-3
1.2 AT90USBKey Features	1-4

Section 2

Using the AT90USBKey	2-5
2.1 Overview	2-5
2.2 Power Supply	2-6
2.3 Reset	2-8
2.4 On-board Resources	2-9
2.5 In-System Programming	2-13
2.6 Debugging	2-14

Section 3

Troubleshooting Guide	3-15
-----------------------------	------

Section 4

Technical Specifications	4-16
--------------------------------	------

Section 5

Technical Support	5-17
-------------------------	------

Section 6

Complete Schematics	6-18
---------------------------	------



Section 1

Introduction

Congratulations on acquiring the AVR® AT90USBKey. This kit is designed to give designers a quick start to develop code on the AVR® and for prototyping and testing of new designs with the AT90USB microcontroller family.

1.1 Overview

This document describes the AT90USBKey dedicated to the AT90USB AVR microcontroller. This board is designed to allow an easy evaluation of the product using demonstration software.

To increase its demonstrative capabilities, this stand alone board has numerous on-board resources: USB, joystick, data-flash and temperature sensor.

Figure 1-1 . AT90USBKey

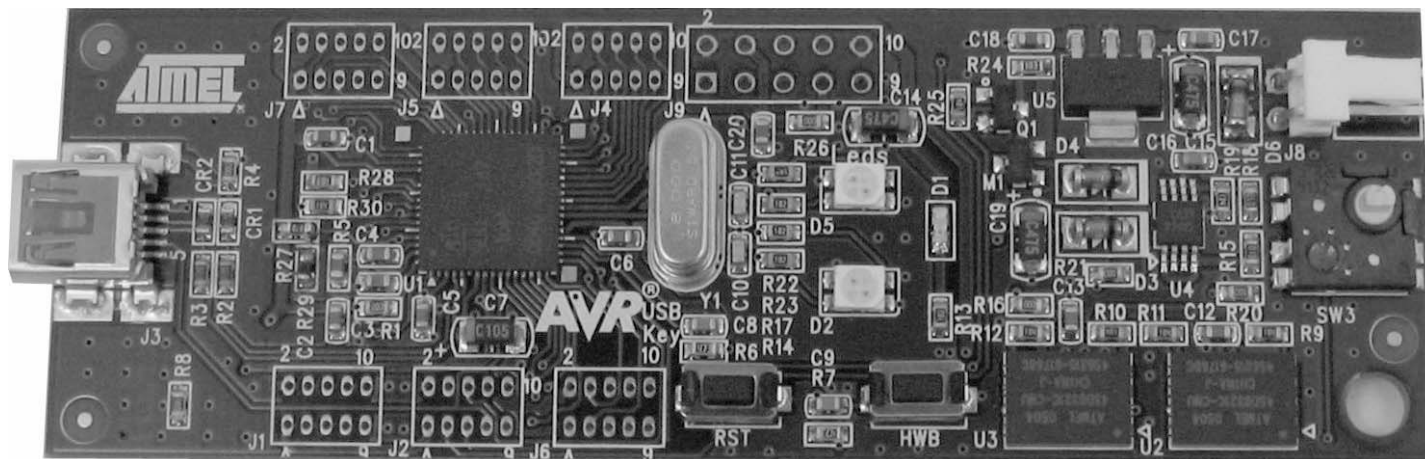

1.2 AT90USBKey Features

The AT90USBKey provides the following features:

- AT90USB QFN64
- AVR Studio® software interface ⁽¹⁾
- USB software interface for Device Firmware Upgrade (DFU bootloader) ⁽²⁾
- Power supply flagged by “VCC-ON” LED:
 - regulated 3.3V
 - from an external battery connector (for reduced host or OTG operation)
 - from the USB interface (USB device bus powered application)
- JTAG interface (connector not mounted):
 - for on-chip ISP
 - for on-chip debugging using JTAG ICE
- Serial interfaces:
 - 1 USB full/low speed device/host/OTG interface
- On-board resources:
 - 4+1-ways joystick
 - 2 Bi-Color LEDs
 - temperature sensor
 - serial dataflash memories
 - all microcontroller I/O ports access on 2x8pin headers (not mounted)
- On-board RESET button
- On-board HWB button to force bootloader section execution at reset.
- System clock:
 - 8 MHz crystal

- Notes:
1. The AVRUSBKey is supported by AVR Studio®, version 4.12 or higher. For up-to-date information on this and other AVR tool products, please consult our web site. The most recent version of AVR Studio®, AVR tools and this User Guide can be found in the AVR section of the Atmel web site, <http://www.atmel.com>.
 2. ATMEL Flip®, In System Programming Version 3 or Higher shall be used for Device Firmware Upgrade. Please consult Atmel web site to retrieve the latex version of Flip and the DFU bootloader Hex file if needed.

Using the AT90USBKey

This chapter describes the AVRUSBKey and all its resources.

2.1 Overview

Figure 2-1 . AT90USBKey Overview

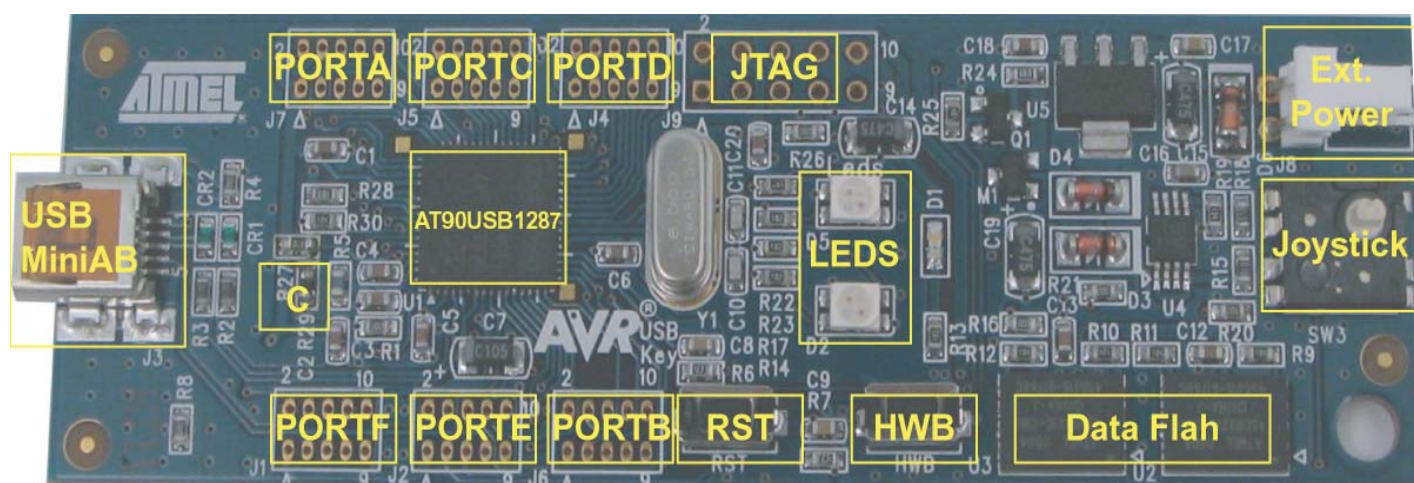

2.2 Power Supply

2.2.1 Power Supply Sources

The on-board power supply circuitry allows two power supply configurations:

- from USB connector
- from battery connector

USB powered When used as a USB device bus powered application, the AVRUSBKey can be directly powered via the USB VBUS power supply line.

Battery powered The external battery connector should be used when the AT90USBKey is used as a USB host. This mode allows the AT90USBKey to provide a 5V power supply from its VBUS pin.

- Need of a female battery clip
- Input supply from 8 up to 15V DC (min. 100mA)

Figure 2-2 . Power supply schematic

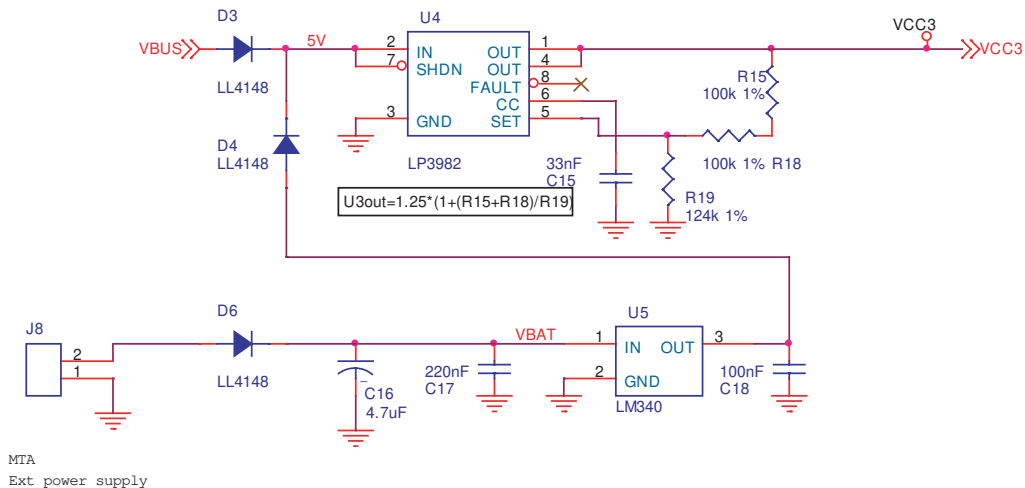

2.2.2 VBUS Generator

When using the AT90USB microcontroller in USB host mode, the AT90USBKey should provide a 5V power supply over the VBUS pin of its USB mini AB connector.

A couple of transistors allows the UVCON pin of the AT90USB to control the VBUS generation (See Figure 2-3). In this mode the AT90USBKey is powered by external battery power supply source.

Figure 2-3 . VBUS generator schematic

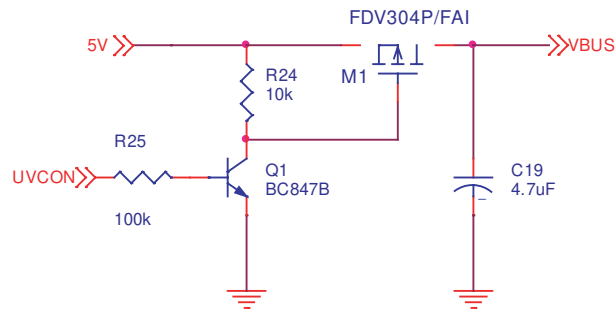

2.2.3 “POWER-ON“ LED

The POWER-ON LED (“D1”) is always lit when power is applied to AVRUSBKey regardless of the power supply source.

2.3 Reset

Although the AT90USB has its on-chip RESET circuitry (c.f. AT90USB Datasheet, section “System Control and Reset), the AVRUSBKey provides to the AT90USB a RESET signal witch can come from two different sources:

Figure 2-4 . Reset Implementation

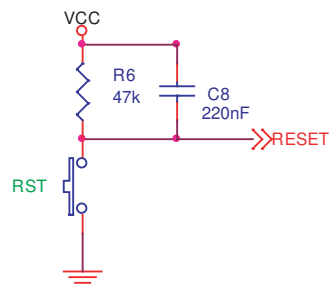

2.3.1 Power-on RESET

The on-board RC network acts as power-on RESET.

2.3.2 RESET Push Button

By pressing the RESET push button on the AVRUSBKey, a warm RESET of the AT90USB is performed.

2.3.3 Main Clock XTAL

To use the USB interface of the AT90USB, the clock source should always be a crystal or external clock oscillator (the internal 8MHz RC oscillator can not be used to operate with the USB interface). Only the following crystal frequency allows proper USB operations: 2MHz, 4MHz, 6MHz, 8MHz, 12MHz, 16MHz. The AT90USBKey comes with a default 8MHz crystal oscillator.

2.4 On-board Resources

2.4.1 USB

The AVRUSBKey is supplied with a standard USB mini A-B receptacle. The mini AB receptacle allows to connect both a mini A plug or a mini B plug connectors.

Figure 2-5 . USB mini A-B Receptacle

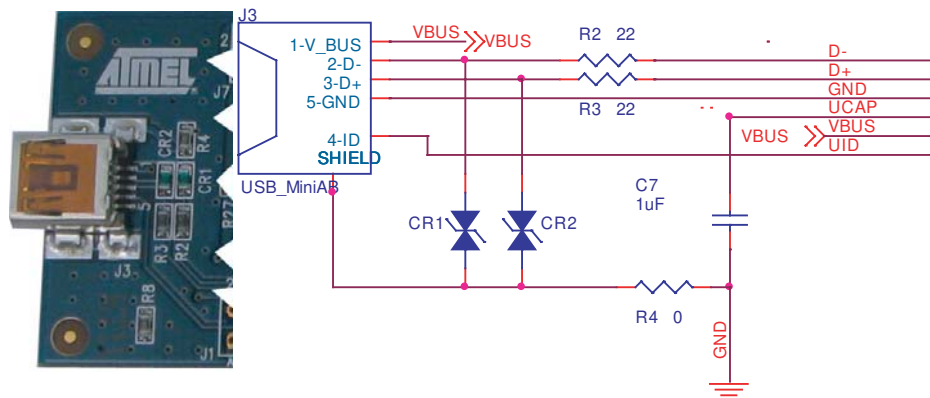

When connected to a mini B plug, the AT90USB operates as an “USB device” (the ID pin of the plug is unconnected) and when connected to a mini A plug, the AT90USB operates as a “USB host” (the ID pin of the A plug is tied to ground).

2.4.2 Joystick

The 4+1 ways joystick offers an easy user interface implementation for a USB application (it can emulate mouse movements, keyboard inputs...).

Pushing the push-button causes the corresponding signal to be pulled low, while releasing (not pressed) causes an H.Z state on the signal. The user must enable internal pull-ups on the microcontroller input pins, removing the need for an external pull-up resistors on the push-button.

Figure 2-6 . Joystick Schematic

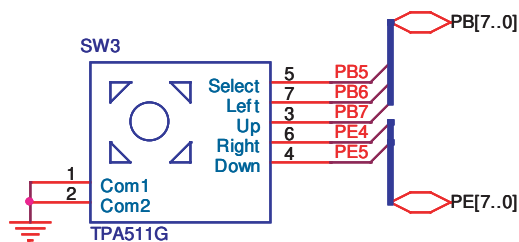

2.4.3 LEDs

The AT90USBKey includes 2 bi-color LEDs (green/red) implemented on one line. They are connected to the high nibble of “Port D” of AT90USB (PORTD[4..7]). To light on a LED, the corresponding port pin must drive a high level. To light off a LED, the corresponding port pin must drive a low level.

Figure 2-7 . LEDs Implementation schematic

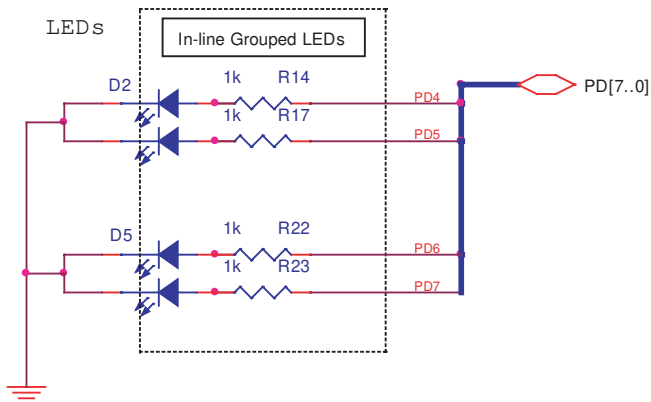

Table 2-1 . Leds references

LED Reference	AT90USB Connection	Color
D2	PORTD.4	Red
	PORTD.5	Green
D5	PORTD.6	Green
	PORTD.7	Red

2.4.4 Temperature Sensor

The temperature sensor uses a thermistor (R29), or temperature-sensitive resistor. This thermistor has a negative temperature coefficient (NTC), meaning the resistance goes up as temperature goes down. Of all passive temperature measurement sensors, thermistors have the highest sensitivity (resistance change per degree of temperature change). Thermistors do not have a linear temperature/resistance curve.

The voltage over the NTC can be found using the A/D converter (connected to channel 0). See the AT90USB Datasheet for how to use the ADC. The thermistor value (R_T) is calculated with the following expression:

$$R_T = (R_H \cdot V_{ADC0}) / (V_{CC} - V_{ADC0})$$

Where:

- R_T = Thermistor value (Ω) at T temperature ($^{\circ}$ Kelvin)
- R_H = Second resistor of the bridge -100 K Ω \pm 10% at 25 $^{\circ}$ C
- V_{ADC0} = Voltage value on ADC-0 input (V)
- V_{CC} = Board power supply

The NTC thermistor used in AT90USBKey has a resistance of 100 K Ω \pm 5% at 25°C (T_0) and a beta-value of 4250 \pm 3%. By the use of the following equation, the temperature (T) can be calculated:

$$T = \frac{\beta}{\left(\ln \frac{R_T}{R_0}\right) + \frac{\beta}{T_0}}$$

Where: R_T = Thermistor value (Ω) at T temperature ($^{\circ}$ Kelvin)
 β = 4250 \pm 3%
 R_0 = 100 K Ω \pm 5% at 25°C
 T_0 = 298 $^{\circ}$ K (273 $^{\circ}$ K + 25 $^{\circ}$ K)

The following cross table also can be used. It is based on the above equation.

Table 2-2. Thermistor Values versus Temperature

Temp. ($^{\circ}$ C)	R_T (K Ω)	Temp. ($^{\circ}$ C)	R_T (K Ω)	Temp. ($^{\circ}$ C)	R_T (K Ω)	Temp. ($^{\circ}$ C)	R_T (K Ω)
-20	1263,757	10	212,958	40	50,486	70	15,396
-19	1182,881	11	201,989	41	48,350	71	14,851
-18	1107,756	12	191,657	42	46,316	72	14,329
-17	1037,934	13	181,920	43	44,380	73	13,828
-16	973,006	14	172,740	44	42,537	74	13,347
-15	912,596	15	164,083	45	40,781	75	12,885
-14	856,361	16	155,914	46	39,107	76	12,442
-13	803,984	17	148,205	47	37,513	77	12,017
-12	755,175	18	140,926	48	35,992	78	11,608
-11	709,669	19	134,051	49	34,542	79	11,215
-10	667,221	20	127,555	50	33,159	80	10,838
-9	627,604	21	121,414	51	31,840	81	10,476
-8	590,613	22	115,608	52	30,580	82	10,128
-7	556,056	23	110,116	53	29,378	83	9,793
-6	523,757	24	104,919	54	28,229	84	9,471
-5	493,555	25	100,000	55	27,133	85	9,161
-4	465,300	26	95,342	56	26,085	86	8,863
-3	438,854	27	90,930	57	25,084	87	8,576
-2	414,089	28	86,750	58	24,126	88	8,300
-1	390,890	29	82,787	59	23,211	89	8,035
0	369,145	30	79,030	60	22,336	90	7,779
1	348,757	31	75,466	61	21,498	91	7,533
2	329,630	32	72,085	62	20,697	92	7,296
3	311,680	33	68,876	63	19,930	93	7,067
4	294,826	34	65,830	64	19,196	94	6,847



Temp. (°C)	R _T (KΩ)	Temp. (°C)	R _T (KΩ)	Temp. (°C)	R _T (KΩ)	Temp. (°C)	R _T (KΩ)
5	278,995	35	62,937	65	18,493	95	6,635
6	264,119	36	60,188	66	17,820	96	6,430
7	250,134	37	57,576	67	17,174	97	6,233
8	236,981	38	55,093	68	16,556	98	6,043
9	224,606	39	52,732	69	15,964	99	5,860

Figure 2-8 . Thermistor Schematic

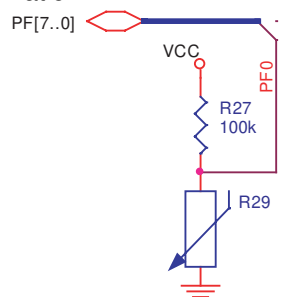

2.4.5 Data Flash memory

For mass-storage class demonstration purpose, the AT90USBKey provides two on-chip serial Flash memories (AT45DB642D) connected to the AT90USB Serial Port Interface (SPI).

The data-flash chip select signals are connected to PortE bit 0 and bit 1 of the AT90USB (See Figure 2-9).

Figure 2-9 . On-board data flash schematic

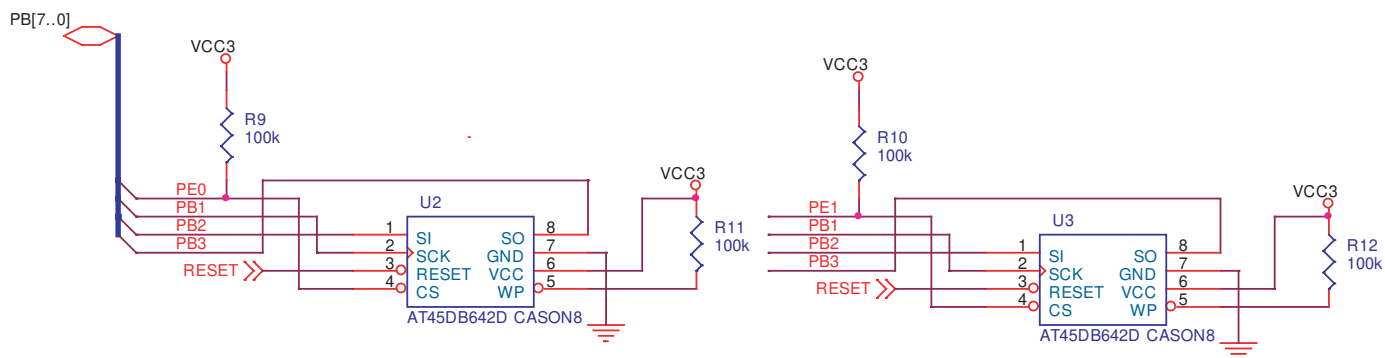

2.5 In-System Programming

2.5.1 Programming with USB bootloader: DFU (Device Firmware Upgrade)

AT90USB part comes with a default factory pre-programmed USB bootloader located in the on-chip boot section of the AT90USB. This is the easiest and fastest way to reprogram the device directly over the USB interface. The “Flip” PC side application, is available from the Atmel website, offers a flexible and user friendly interface to reprogram the application over the USB bus.

The HWB pin of the AT90USB allows to force the bootloader section execution after reset. (Refer to AT90USB datasheet section “boot loader support”). To force bootloader execution, operate as follow:

- Press both “RST” and “HWB” push buttons
- First release the “RST” push button
- Release the “HWB” push button

For more information about the USB bootloader and “Flip” application, please refer to the “USB bootloader datasheet document” and “Flip’s user manual”.

Note: The HWB pin is active only if the HWBE fuse is set (default factory configuration).

2.5.2 Programming with AVR JTAGICEmkII

The AT90USB can be programmed using specific JTAG link. To use the AVR JTAGICEmkII with an AT90USBKey an optional HE10 connector should be soldered to J9 footprint. Then the JTAG probe can be connected to the AT90USBKey as shown in Figure 2-10.

Note: When the JTAGEN Fuse is unprogrammed, the four TAP pins are normal port pins, and the TAP controller is in reset. When programmed, the input TAP signals are internally pulled high and the JTAG is enabled for Boundary-scan and programming. The AT90USB device is shipped with this fuse programmed.

Figure 2-10 . Connecting AVR JTAG ICE to AVRUSBKey

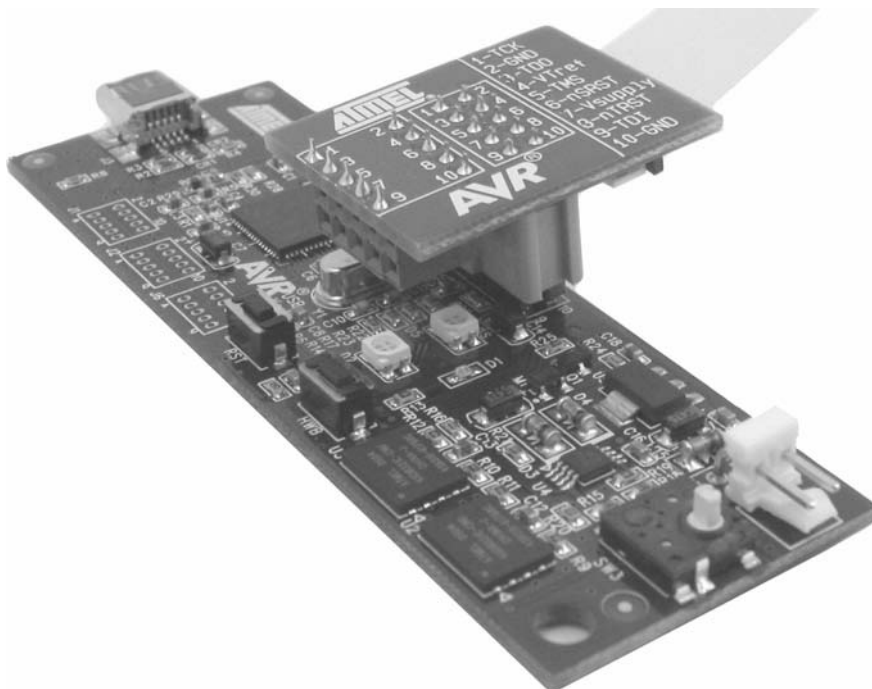

The Flash, EEPROM and all Fuse and Lock Bit options ISP-programmable can be programmed individually or with the sequential automatic programming option.

Note: See AVR Studio® on-line Help for information.

2.6 Debugging

2.6.1 Debugging with AVR JTAG ICE mkII

The AT90USBKey can be used for debugging with JTAG ICE MK II.

Connect the JTAG ICE mkII as shown in Figure 2-10, for debugging, please refer to AVR Studio® Help information.

When using JTAG ICE MK II for debugging, and as AT90USB parts are factory configured with the higher security level set, a chip erase operation will be performed on the part before debugging. Thus the on-chip flash bootloader will be erased. It can be restored after the debug session using the bootloader hex file available from ATMEL website.



Section 3

Troubleshooting Guide

Figure 3-1 . Troubleshooting Guide

Problem	Reason	Solution
The Green "VCC-ON" LED is not on	No power supply	Verify the power supply source (check battery charge or USB connection).
AVRUSBKey does not work		
The AT90USB cannot be programmed	The AVR JTAG ICE probe is not connected	Connect the JTAG ICE 10-PIN header to the correct AVRUSBKey JTAG header (page 13)
	The memory lock bits are programmed	Erase the memory before programming with JTAG ICE.
	The fuse bits are wrongly programmed	Check the fuse bits with JTAG ICE
	Can not connect to USB bootloader	Force bootloader execution with HWB under reset. USB bootloader erased after a JTAG debugging session: reprogram the USB bootloader with JTAG.
AVR Studio does not detect the AVR JTAG ICE.	Serial/USB cable is not connected, or power is off	Connect serial cable to RS232 (STK500 - AVR ISP) and check power connections
		Connect serial cable to USB (JATG ICE MKII, AVR ISPMkIII) and check power connections
	PC COM port is in use	Disable other programs that are using PC COM port. Change PC COM port
AVR Studio does not detect COM port.	AVR Studio does not detect COM port.	Disable COM port auto-detection in AVR Studio file menu. Force COM port to correct COM port



Section 4

Technical Specifications

■ System Unit

- Physical DimensionsL=90 x W=30 x H=8 mm
- Weight..... 12 g

■ Operating Conditions

- Internal Voltage Supply 3.3V
- External Voltage Supply8V -15V

■ Connections

- USB ConnectorMini AB receptacle
- USB Communications Full speed/low speed
- JTAG Connector..... Footprint for HE10 connector
- All ports connectors.....J1, J2, J4, J5, J6, J7
- Battery connector MTA right angle



Section 5

Technical Support

For Technical support, please contact avr@atmel.com. When requesting technical support, please include the following information:

- Which target AVR device is used (complete part number)
- Target voltage and speed
- Clock source and fuse setting of the AVR
- Programming method (ISP, JTAG or specific Boot-Loader)
- Hardware revisions of the AVR tools, found on the PCB
- Version number of AVR Studio. This can be found in the AVR Studio help menu.
- PC operating system and version/build
- PC processor type and speed
- A detailed description of the problem



Section 6

Complete Schematics

On the next pages, the following documents of AT90USBKey are shown:

- Complete schematics,
- Bill of materials.

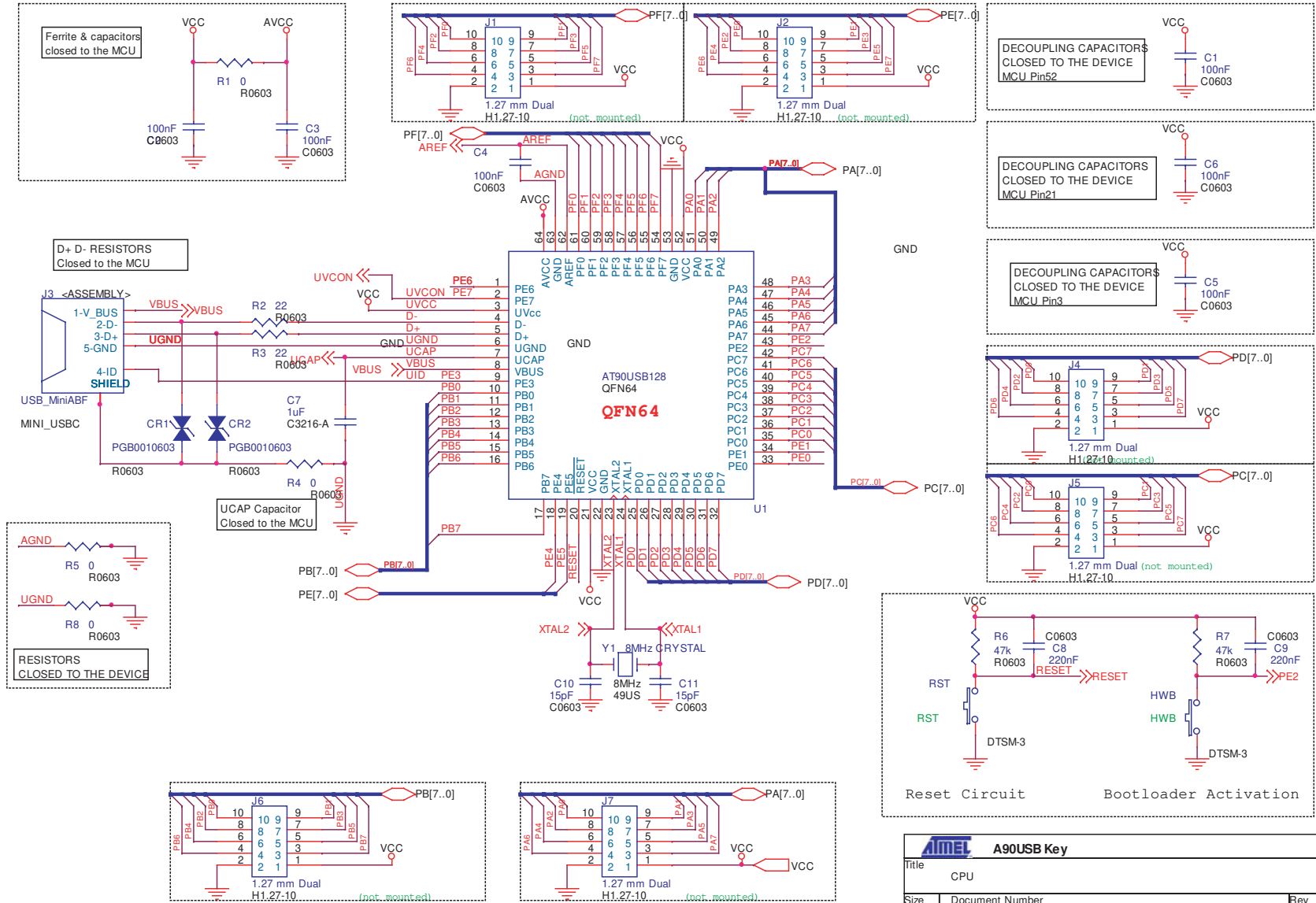
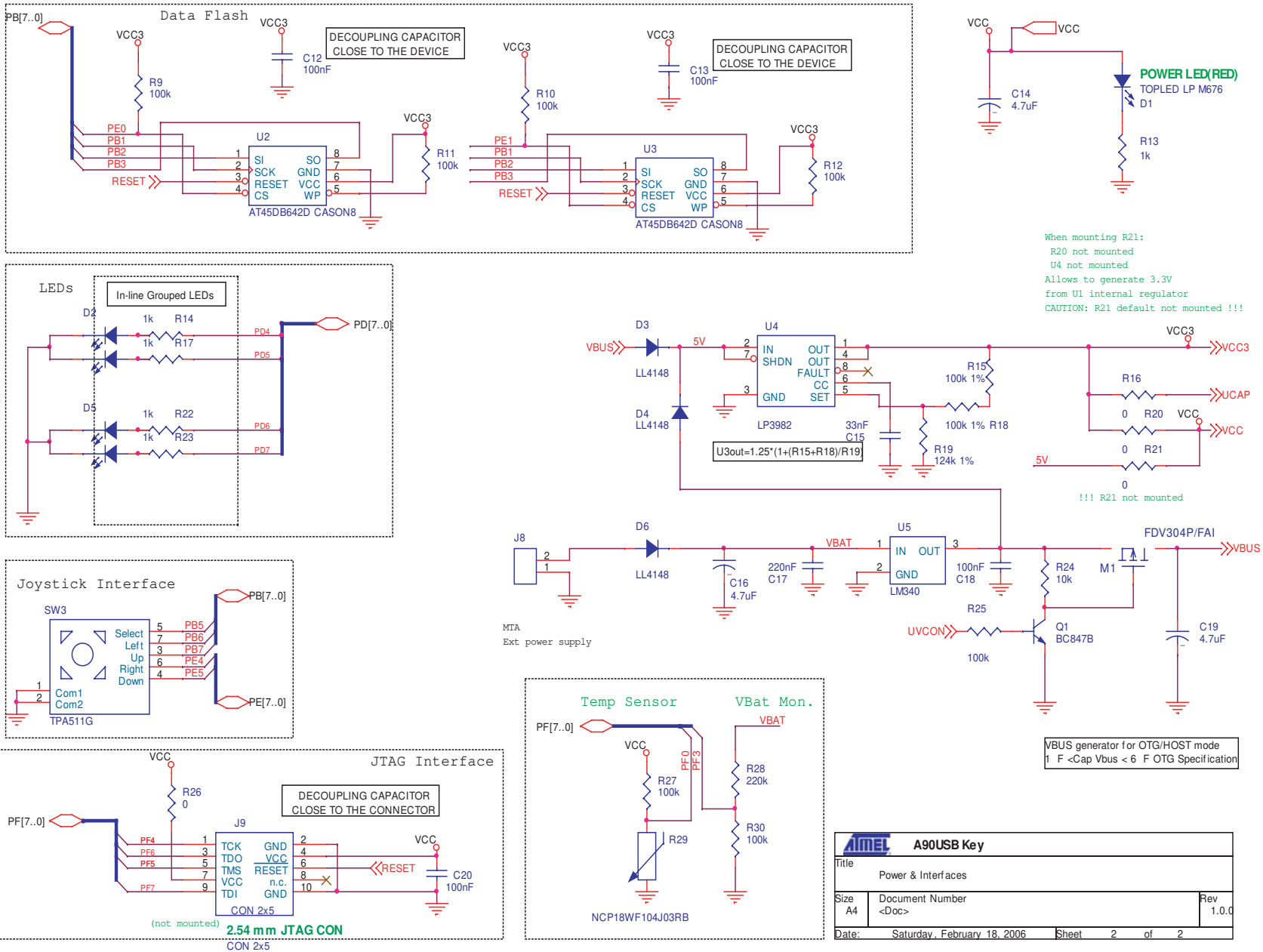

Figure 6-1. Schematics, 1 of 2

Atmel A90USB Key		
Title CPU		
Size A4	Document Number <Doc>	Rev 1.0.0
Date: Monday, January 09, 2006	Sheet 1	of 2

Figure 6-2. Schematics, 2 of 2



ATMEL A90USB Key		
Title: Power & Interfaces		
Size: A4	Document Number: <Doc>	Rev: 1.0.0
Date: Saturday, February 18, 2006	Sheet: 2 of 2	

Table 6-1 . Bill of material

Item	Q.ty	Reference	Part	Tech. Characteristics	Package
1	2	CR1,CR2	ESD protection (PGB0010603)		
2	10	C1,C2,C3,C4,C5,C6,C12, C13, C18, C20	100nF	50V-10% Ceramic	CASE 0603
3	1	C7	1uF	10Vmin ±10%	EIA/IECQ 3216
4	3	C8,C9, C17	220nF	50V-10% Ceramic	CASE 0603
5	2	C10, C11	15pF	50V-5% Ceramic	CASE 0603
6	3	C14, C16, C19	4.7uF	10Vmin ±10%	EIA/IECQ 3216
7	1	C15	33nF	50V-5% Ceramic	CASE 0603
8	2	D2,D5	LED BI-COLOUR/ LSGT670	I=10 mA	PLCC-4
9	1	D1	TOPLED/ LPM676-K2M1	I=10 mA	PLCC-2
10	2	D3,D4	DII LL4148-7	i=200mA max	LL-34
11	1	J3	USB mini AB receptacle Surface mount		
12	0	J9	CON 2x5 (2.54mm)	(Not Mounted)	
13	0	J1,J2,J4,J5,J6,J7	1.27 mm Dual header	(Not Mounted)	
14	1	J8	Connector MTA 2 cts right angle		
15	1	M1	FDV304P/FAI		SOT23
16	1	Q1	BC847B	IC peak=200mA	SOT23
17	2	R2,R3	22	1/16W-5% SMD	CASE 0603
18	1	R5	68k	1/16W-5% SMD	CASE 0603
19	2	R6,R7	47k	1/16W-5% SMD	CASE 0603
20	7	R1,R4,R5,R8,R16,R20, R26	0		CASE 0603
21	0	R21	0	(Not Mounted)	CASE 0603
22	1	R28	220k	1/16W-5% SMD	CASE 0603
23	7	R9,R10,R11,R12,R25,R27,R3 0	100k	1/16W-5% SMD	CASE 0603
24	5	R13,R14,R17,R22,R23	1k	1/16W-5% SMD	CASE 0603
25	2	R24,R28	10k	1/16W-5% SMD	CASE 0603
26	1	R29	NCP18WF104J03RB	100K - β=4250	CASE 0603
27	2	R15,R18	100k 1%	1/16W-1% SMD	CASE 0603
28	1	R19	120k 1%	1/16W-1% SMD	CASE 0603
29	2	SW1,SW2	PUSH-BUTTON / DTSM31N	6x3.5mm - 1.6N	See DS
30	1	SW3	TPA511G 4 ways joystick + center CMS mount		
31	1	U1	AT90USB1287		QFN64
32	2	U2,U3	AT45DB642D		CASON8
33	1	U4	LP3982IMM-ADJ	Vin Max 6V, 300mA	MSOP8
34	1	U6	LM340MP5.0		
35	1	Y1	8MHz CRYSTAL	H=4mm	HC49/4H



Atmel Corporation

2325 Orchard Parkway
San Jose, CA 95131, USA
Tel: 1(408) 441-0311
Fax: 1(408) 487-2600

Regional Headquarters

Europe

Atmel Sarl
Route des Arsenaux 41
Case Postale 80
CH-1705 Fribourg
Switzerland
Tel: (41) 26-426-5555
Fax: (41) 26-426-5500

Asia

Room 1219
Chinachem Golden Plaza
77 Mody Road Tsimshatsui
East Kowloon
Hong Kong
Tel: (852) 2721-9778
Fax: (852) 2722-1369

Japan

9F, Tonetsu Shinkawa Bldg.
1-24-8 Shinkawa
Chuo-ku, Tokyo 104-0033
Japan
Tel: (81) 3-3523-3551
Fax: (81) 3-3523-7581

Atmel Operations

Memory

2325 Orchard Parkway
San Jose, CA 95131, USA
Tel: 1(408) 441-0311
Fax: 1(408) 436-4314

Microcontrollers

2325 Orchard Parkway
San Jose, CA 95131, USA
Tel: 1(408) 441-0311
Fax: 1(408) 436-4314

La Chantrerie
BP 70602
44306 Nantes Cedex 3, France
Tel: (33) 2-40-18-18-18
Fax: (33) 2-40-18-19-60

ASIC/ASSP/Smart Cards

Zone Industrielle
13106 Rousset Cedex, France
Tel: (33) 4-42-53-60-00
Fax: (33) 4-42-53-60-01

1150 East Cheyenne Mtn. Blvd.
Colorado Springs, CO 80906, USA
Tel: 1(719) 576-3300
Fax: 1(719) 540-1759

Scottish Enterprise Technology Park
Maxwell Building
East Kilbride G75 0QR, Scotland
Tel: (44) 1355-803-000
Fax: (44) 1355-242-743

RF/Automotive

Theresienstrasse 2
Postfach 3535
74025 Heilbronn, Germany
Tel: (49) 71-31-67-0
Fax: (49) 71-31-67-2340

1150 East Cheyenne Mtn. Blvd.
Colorado Springs, CO 80906, USA
Tel: 1(719) 576-3300
Fax: 1(719) 540-1759

Biometrics/Imaging/Hi-Rel MPU/ High Speed Converters/RF Datacom

Avenue de Rochepleine
BP 123
38521 Saint-Egreve Cedex, France
Tel: (33) 4-76-58-30-00
Fax: (33) 4-76-58-34-80

Literature Requests

www.atmel.com/literature

Disclaimer: The information in this document is provided in connection with Atmel products. No license, express or implied, by estoppel or otherwise, to any intellectual property right is granted by this document or in connection with the sale of Atmel products. **EXCEPT AS SET FORTH IN ATMEL'S TERMS AND CONDITIONS OF SALE LOCATED ON ATMEL'S WEB SITE, ATMEL ASSUMES NO LIABILITY WHATSOEVER AND DISCLAIMS ANY EXPRESS, IMPLIED OR STATUTORY WARRANTY RELATING TO ITS PRODUCTS INCLUDING, BUT NOT LIMITED TO, THE IMPLIED WARRANTY OF MERCHANTABILITY, FITNESS FOR A PARTICULAR PURPOSE, OR NON-INFRINGEMENT. IN NO EVENT SHALL ATMEL BE LIABLE FOR ANY DIRECT, INDIRECT, CONSEQUENTIAL, PUNITIVE, SPECIAL OR INCIDENTAL DAMAGES (INCLUDING, WITHOUT LIMITATION, DAMAGES FOR LOSS OF PROFITS, BUSINESS INTERRUPTION, OR LOSS OF INFORMATION) ARISING OUT OF THE USE OR INABILITY TO USE THIS DOCUMENT, EVEN IF ATMEL HAS BEEN ADVISED OF THE POSSIBILITY OF SUCH DAMAGES.** Atmel makes no representations or warranties with respect to the accuracy or completeness of the contents of this document and reserves the right to make changes to specifications and product descriptions at any time without notice. Atmel does not make any commitment to update the information contained herein. Unless specifically provided otherwise, Atmel products are not suitable for, and shall not be used in, automotive applications. Atmel's products are not intended, authorized, or warranted for use as components in applications intended to support or sustain life.

© Atmel Corporation 2006. All rights reserved. Atmel®, logo and combinations thereof, are registered trademarks, and Everywhere You Are® are the trademarks of Atmel Corporation or its subsidiaries. Other terms and product names may be trademarks of others.



Printed on recycled paper.